



Expert
+PLUS™



Giant®

Enhancing everyday living

RESIDENTIAL ELECTRIC WATER HEATERS

EXPERT PLUS™

| 30 | 40 | 60 | IMP. GALLONS

BENEFITS

1 - GLASS-LINED INNER TANK

A coating of a uniquely formulated blue cobalt glass enriched with zircon is fused to specially treated steel at 1,600°F (871°C) to provide the best coating available against corrosion for many years. The tank is certified at a test pressure of 300 PSI (2,068 kPa) and a working pressure of 150 PSI (1,034 kPa).

2 - MEDIUM WATT DENSITY SCREW-IN TYPE ELECTRIC ELEMENTS

These models are equipped with medium density CSA approved screw-in immersion elements.



3 - INSULATION

A two (2) inch (5 cm) thick uniform blanket of ecofriendly insulation keeps the water hotter for longer periods, reduces stand-by losses and energy costs. It contains no HCFC'S (hydrochlorofluorocarbons), CFC'S (chlorofluorocarbons) nor VOC'S (volatile organic compounds).

4 - FACTORY INSTALLED 3/4" NPT DI-ELECTRIC NIPPLES

Extend the life of the water heater by providing excellent corrosion protection.

5 - FACTORY INSTALLED HEAT TRAPS

Helps reduce the migration of hot water, thus limiting heat loss escaping through inlet and outlet fittings.

6 - FACTORY INSTALLED TEMPERATURE & PRESSURE-RELIEF VALVE

This valve will protect the tank from the damaging effects of excessive temperature and pressure.

7 - HIGH QUALITY MAGNESIUM ANODE

Provides excellent protection against the corrosive effects of water and extends tank life.

8 - OVERFLOW SYSTEM

A 90° elbow overflow tube is supplied with each residential electric water heater.

9 - BRASS DRAIN VALVE

A high quality and tamper resistant one-piece brass drain valve is installed for easy drainage.

10 - AUTOMATIC TEMPERATURE CONTROL

Adjustable thermostats will provide years of reliable trouble-free service at the desired water temperature and a safety cut-off is provided for abnormal conditions.

Expert +PLUS™

The Choice of Experts!

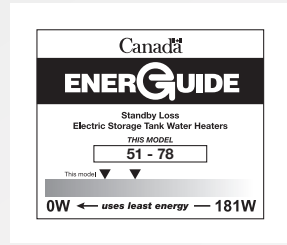
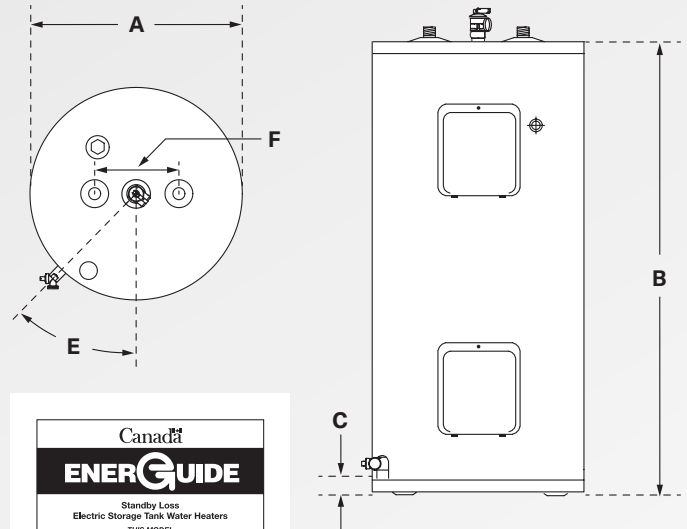

SPECIFICATIONS & DIMENSIONS

Models	Storage Capacity			Factory installed wattages						Standby loss watts	Diameter (A)		Height (B)		C		E	F		Est. ship. weight	
				120V		208V		240V			inches	(cm)	inches	(cm)	inches	(cm)		inches	(cm)		
	US gal.	Liters	IMP gal.	watts	amp	watts	amp	watts	amp												
142STE-E8	36	135	30	1,500	12.50	3,000	14.42	3,000	12.50	51	22	(56)	36 1/4	(92)	2 1/8	(5)	45°	8	(20)	115	(52)
152STE-E8	49	184	41	1,500	12.50	3,000	14.42	3,000	12.50	62	22	(56)	49 1/4	(125)	2 1/8	(5)	45°	8	(20)	140	(64)
152STE-E8-AA	49	184	41	N/A	N/A	N/A	N/A	3,800	15.80	62	22	(56)	49 1/4	(125)	2 1/8	(5)	45°	8	(20)	140	(64)
172STE-E8	74	279	61	1,500	12.50	4,500	21.63	4,500	18.75	78	24	(61)	59 7/8	(152)	2 1/8	(5)	45°	8	(20)	185	(84)
172STE-E8-AA	74	279	61	N/A	N/A	N/A	N/A	3,800	15.80	78	24	(61)	59 7/8	(152)	2 1/8	(5)	45°	8	(20)	185	(84)

Toxic chemicals, such as those used for boiler treatment, must NEVER be introduced into this system. This unit must NEVER be connected to any existing heating system or component(s) previously used with a non-potable water heating appliance.

WARRANTY

8 years

against inner tank leakage

8 years

on component parts

Giant offers an EIGHT (8) year extended warranty against inner tank leakage from the date of installation for all Expert Plus residential electric water heaters. An EIGHT (8) year extended warranty is also offered on component parts. For more specific warranty details including exceptions, consult the owner's manual provided with each water heater.

Giant®

11021, Notre-Dame Street East, Montreal-East, Quebec, Canada, H1B 5H3
 Telephone : 514-645-8893 • Toll free : 1-800-363-9354
 General fax : 514-640-0969
 Customer Service fax : 514-645-8413

giantinc.com