



Expert
+PLUS.

Giant[®]

Enhancing everyday living

RESIDENTIAL ELECTRIC WATER HEATERS

EXPERT PLUS™

| 30 | 40 | 60 | IMP. GALLONS

BENEFITS

1 - GLASS-LINED INNER TANK

A coating of a uniquely formulated blue cobalt glass enriched with zircon is fused to specially treated steel at 1,600°F (871°C) to provide the best coating available against corrosion for many years. The tank is certified at a test pressure of 300 PSI (2,068 kPa) and a working pressure of 150 PSI (1,034 kPa).

2 - MEDIUM WATT DENSITY SCREW-IN TYPE A ELECTRIC ELEMENTS

These models are equipped with medium density CSA approved screw-in immersion elements.



3 - INSULATION

A two (2) inch (5 cm) thick uniform blanket of ecofriendly insulation keeps the water hotter for longer periods, reduces stand-by losses and energy costs. It contains no HCFC'S (hydrochlorofluorocarbons), CFC'S (chlorofluorocarbons) nor VOC's (volatile organic compounds).

4 - FACTORY INSTALLED 3/4" NPT DI-ELECTRIC NIPPLES

Extend the life of the water heater by providing excellent corrosion protection.

5 - FACTORY INSTALLED HEAT TRAPS

Helps reduce the migration of hot water, thus limiting heat loss escaping through inlet and outlet fittings.

6 - FACTORY INSTALLED TEMPERATURE & PRESSURE-RELIEF VALVE

This valve will protect the tank from the damaging effects of excessive temperature and pressure.

7 - HIGH QUALITY MAGNESIUM ANODE

Provides excellent protection against the corrosive effects of water and extends tank life.

8 - OVERFLOW SYSTEM

A 90° elbow overflow tube is supplied with each residential electric water heater.

9 - BRASS DRAIN VALVE

A high quality and tamper resistant one-piece brass drain valve is installed for easy drainage.

10 - AUTOMATIC TEMPERATURE CONTROL

Adjustable thermostats will provide years of reliable trouble-free service at the desired water temperature and a safety cut-off is provided for abnormal conditions.

Expert +PLUSSM

The Choice of Experts!

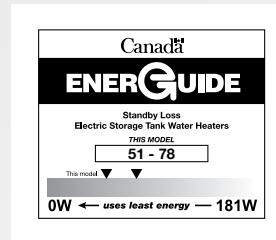
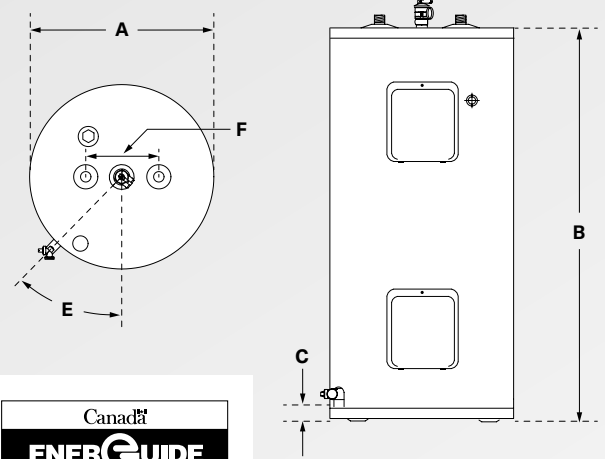

SPECIFICATIONS & DIMENSIONS

Models	Storage Capacity			Input watts	Voltage volts	Standby loss watts	Diameter (A)		Height (B)		C		E	F		Est. ship. weight		Warranty Tank / Parts years
	US gal.	Liters	IMP gal.				inches	(cm)	inches	(cm)	inches	(cm)		inches	(cm)	lb	(kg)	
142STE-1S8M-E6	36	135	30	1,500	120	51	22	(56)	36 1/4	(92)	2 1/8	(5)	45°	8	(20)	115	(52)	6 / 6
142STE-2S8M-E6	36	135	30	3,000	208	51	22	(56)	36 1/4	(92)	2 1/8	(5)	45°	8	(20)	115	(52)	6 / 6
142STE-3S8M-E6	36	135	30	3,000	240	51	22	(56)	36 1/4	(92)	2 1/8	(5)	45°	8	(20)	115	(52)	6 / 6
152STE-1S8M-E6	49	184	41	1,500	120	62	22	(56)	49 1/4	(125)	2 1/8	(5)	45°	8	(20)	140	(64)	6 / 6
152STE-2S8M-E6	49	184	41	3,000	208	62	22	(56)	49 1/4	(125)	2 1/8	(5)	45°	8	(20)	140	(64)	6 / 6
152STE-2S8M-E6EE	49	184	41	4,500	208	62	22	(56)	49 1/4	(125)	2 1/8	(5)	45°	8	(20)	140	(64)	6 / 6
152STE-3S8M-E6	49	184	41	3,000	240	62	22	(56)	49 1/4	(125)	2 1/8	(5)	45°	8	(20)	140	(64)	6 / 6
152STE-3S8M-E8	49	184	41	3,000	240	62	22	(56)	49 1/4	(125)	2 1/8	(5)	45°	8	(20)	140	(64)	8 / 8
152STE-3S8M-E6AA	49	184	41	3,800	240	62	22	(56)	49 1/4	(125)	2 1/8	(5)	45°	8	(20)	140	(64)	6 / 6
152STE-3S8M-E8AA	49	184	41	3,800	240	62	22	(56)	49 1/4	(125)	2 1/8	(5)	45°	8	(20)	140	(64)	8 / 8
152STE-3S8M-E6EE	49	184	41	4,500	240	62	22	(56)	49 1/4	(125)	2 1/8	(5)	45°	8	(20)	140	(64)	6 / 6
172STE-1S8M-E6	74	279	61	1,500	120	78	24	(61)	59 7/8	(152)	2 1/8	(5)	45°	8	(20)	185	(84)	6 / 6
172STE-2S8M-E6	74	279	61	4,500	208	78	24	(61)	59 7/8	(152)	2 1/8	(5)	45°	8	(20)	185	(84)	6 / 6
172STE-2S8M-E6MM	74	279	61	5,000	208	78	24	(61)	59 7/8	(152)	2 1/8	(5)	45°	8	(20)	185	(84)	6 / 6
172STE-3S8M-E6	74	279	61	4,500	240	78	24	(61)	59 7/8	(152)	2 1/8	(5)	45°	8	(20)	185	(84)	6 / 6
172STE-3S8M-E8	74	279	61	4,500	240	78	24	(61)	59 7/8	(152)	2 1/8	(5)	45°	8	(20)	185	(84)	8 / 8
172STE-3S8M-E6CC	74	279	61	3,000	240	78	24	(61)	59 7/8	(152)	2 1/8	(5)	45°	8	(20)	185	(84)	6 / 6
172STE-3S8M-E6AA	74	279	61	3,800	240	78	24	(61)	59 7/8	(152)	2 1/8	(5)	45°	8	(20)	185	(84)	6 / 6
172STE-3S8M-E6OO	74	279	61	6,000	240	78	24	(61)	59 7/8	(152)	2 1/8	(5)	45°	8	(20)	185	(84)	6 / 6

Toxic chemicals, such as those used for boiler treatment, must NEVER be introduced into this system. This unit must NEVER be connected to any existing heating system or component(s) previously used with a non-potable water heating appliance.

WARRANTY		WARRANTY	
6 years	6 years	8 years	8 years
against inner tank leakage	on component parts	against inner tank leakage	on component parts

Giant offers a SIX (6) or EIGHT (8) year extended warranty against inner tank leakage from the date of installation for all Expert Plus residential electric water heaters. A SIX (6) or EIGHT (8) year extended warranty is also offered on component parts. For more specific warranty details including exceptions, consult the owner's manual provided with each water heater.

Giant[®]

11021, Notre-Dame Street East, Montreal-East, Quebec, Canada, H1B 2V5
 Telephone : 514-645-8893 • Toll free : 1-800-363-9354
 General fax : 514-640-0969
 Customer Service fax : 514-645-8413

giantinc.com