



Enhancing everyday living



ENGINEERING SUBMITTAL DATA SHEET

Commercial electric water heaters, Flexible

112 MODELS (Light & Medium Duty)

99 imperial gallons / 450 litres

Insulated with 2" Eco-Friendly **GREENFOAM**

208, 240, 277 & 480 Volts / Single phase

These models meet the safety and construction requirements of CSA Standard C22.2 No. 110 and meet or exceed the standby loss requirements of NRCAN and ASHRAE 90.1 Standard.

Models*	Input (kW)	Amperage				Phase	Number of elements
		208 Volts	240 Volts	277 Volts	480 Volts		
Light Duty (2 elements) & Medium Duty (4 elements)							
1122Y-1-3S	3	14.4	12.5	10.8	6.3	1	2
1122Y-1-4.5S	4.5	21.6	18.8	16.2	9.4		
1122Y-1-5S	5	24.0	20.8	18.1	10.4		
1122Y-1-6S	6	—	25.0	21.7	12.5		
1124Y-1-6S	6	28.8	25.0	21.7	12.5	1	4
1124Y-1-9S	9	43.3	37.5	32.5	18.8		
1124Y-1-10S	10	48.1	41.7	36.1	20.8		
1124Y-1-12S	12	—	50.0	43.3	25.0		

* Replace the "Y" by the letter referring to its voltage (refer to the following "Voltage index" as well as the "Model Number Structure" for further details).

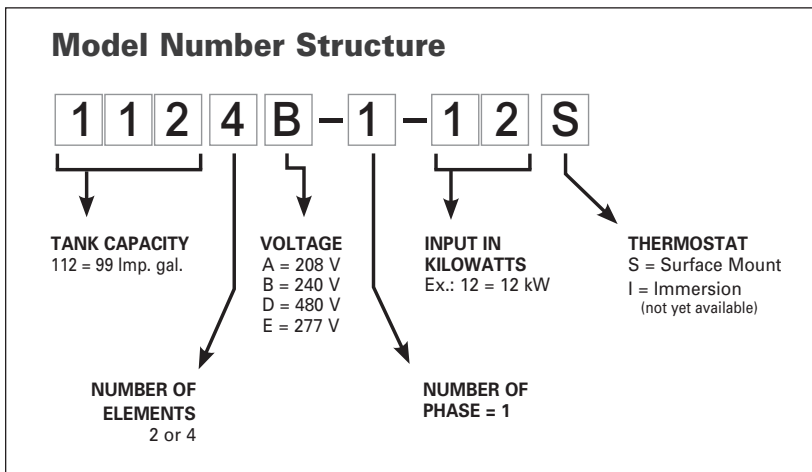

Voltage index	
A	208 Volts
B	240 Volts
D	480 Volts
E	277 Volts

Notes : _____

See reverse for this model drawing as well as order details.

In accordance with our company policy of on-going product improvement, Giant Factories Inc. reserves the right to make changes without prior notice.

giantinc.com



40 Lesage Avenue, Montréal-East (Québec) Canada H1B 5H3 • Telephone: (514) 645-8893 • Fax: (514) 640-0969

Commercial electric water heaters, Flexible
112 MODELS
(Light & Medium Duty)
 99 imperial gallons / 450 litres

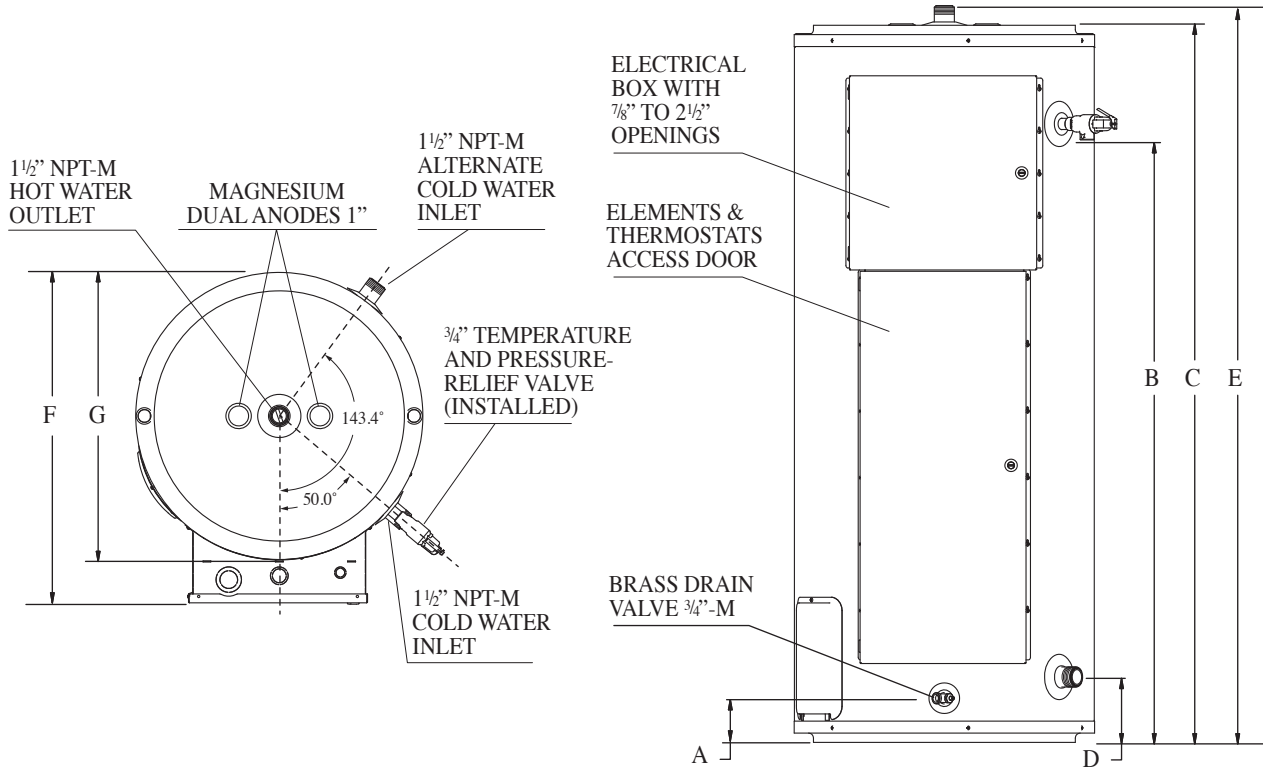

Models	Storage Capacity			A Inches (cm)	B Inches (cm)	C Inches (cm)	D Inches (cm)	E Inches (cm)	F Inches (cm)	G Inches (cm)	Est. Ship. Weight	
	Imp. gal.	Litres	U.S. gal.								lb.	kg
All 112	99	450	119	4 1/8 (10.5)	56 5/8 (143.8)	67 3/8 (171.1)	6 1/8 (15.6)	69 1/4 (175.9)	32 5/8 (82.9)	28 1/4 (71.8)	435	197.3

Notes: _____

JOB TITLE _____

SUBMITTED DATE _____

ADDRESS _____

REQUIRED PRODUCT _____

CONTRACTOR _____

MODEL NO. _____ SIZE _____ QUANTITY _____

ADDRESS _____

MODEL NO. _____ SIZE _____ QUANTITY _____

ENGINEER _____

MODEL NO. _____ SIZE _____ QUANTITY _____

MODEL NO. _____ SIZE _____ QUANTITY _____

REQUIRED DATE _____

In accordance with our company policy of on-going product improvement, Giant Factories Inc. reserves the right to make changes without prior notice.

giantinc.com