



**Giant**<sup>®</sup>

Enhancing everyday living

RESIDENTIAL GAS-FIRED WATER HEATERS

**ATMOSPHERIC VENT  
WITH POWERED DAMPER**

| 40 | 50 | U.S. GALLONS

## ***FLUE DAMPER TO INCREASE EFFICIENCY!***

This atmospheric vent water heater uses its flue damper to increase efficiency and performance by automatically opening and closing the vent to reduce heat loss in standby mode. Environmentally-friendly insulation and factory-installed heat trap nipples also reduce heat loss for maximum energy savings. This tank also includes a heavy-duty magnesium anode rod.

All residential gas fired water heaters built with FVIR technology, meet the latest edition of the North American Standards ANSI Z21.10.1/CSA 4.1.

This model requires power.



## BENEFITS

### TURBULATOR DIP TUBE

Turbulator dip tube reduces sediment build-up at the bottom of the tank.

### POWERED DAMPER

Flue damper for increased energy efficiency and performance.

### 24 VOLT GAS VALVE

24 Volt gas valve offers diagnostic capabilities, monitoring of damper to ensure proper safe operation and spark ignition eliminating the need for a standing pilot.

### EASY TEMPERATURE ADJUSTMENTS

Front positioned gas valve for greater control, comfort, safety and energy efficiency.

### ROBUST 1/4" PILOT TUBING

Robust tubing to withstand the demanding conditions, promote safety, and ensure reliable performance throughout the lifespan of the water heater.

### GLASS-LINED INNER TANK

Glass lining provides superior protection against tank corrosion.

### STANDARD POWER SUPPLY

Plugs into a standard 110/120V outlet (10 ft. power cord included).

### EASY-TO-ACCESS CHAMBER

Front positioned access panel for ease of maintenance and compliance.

### FACTORY INSTALLED T&P RELIEF VALVE AND DRAIN VALVE

Conveniently located temperature and pressure relief valve and brass drain valve for ease of installation and serviceability.

### HIGH-QUALITY ANODE

Top mounted heavy-duty magnesium anode rod for added tank protection.

## MODELS AVAILABLE FOR PROPANE AND NATURAL GAS!



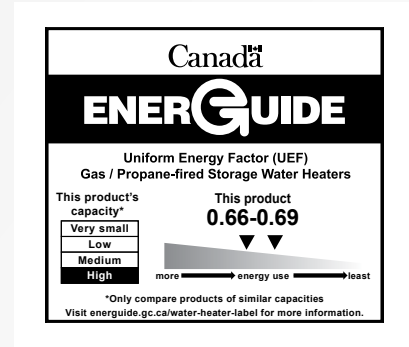
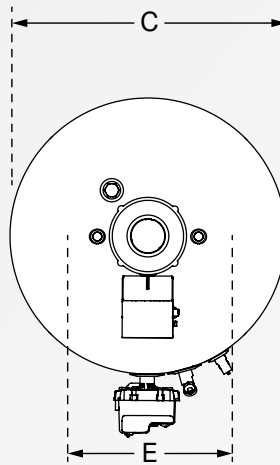
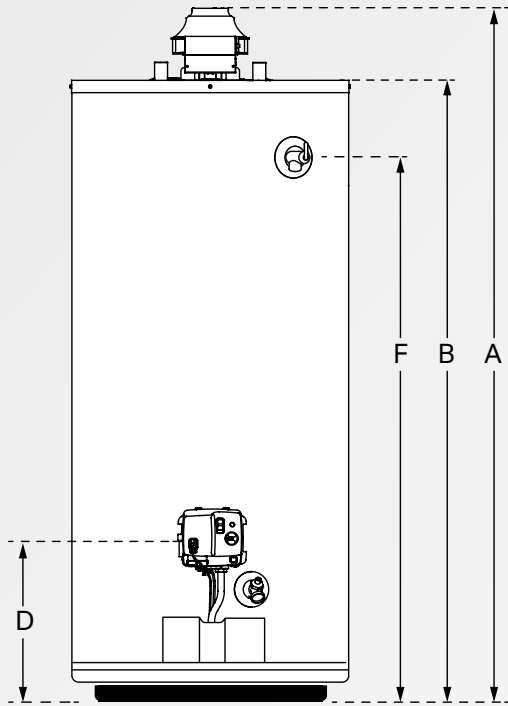

### SPECIFICATIONS

Model	Capacity			Input BTU	Altitude Feet (Meters)	Recovery Rate 90°F / 50°C			First Hour Rating US Gal. (L)	Energy Factor	UEF	Estimated Shipping Weight lb (kg)
	US gal.	Liters	IMP gal.			US gal.	Liters	IMP gal.				
<b>NATURAL GAS</b>												
UG40-40SD3-N2 100	40	151	33	40,000	10,100 (3,078)	41	155	34	67 (254)	0.67	0.66	149 (68)
UG50-40SD3-N2 100	50	189	42	40,000	10,100 (3,078)	41	155	34	81 (307)	0.67	0.69	183 (83)

### DIMENSIONS

Model	A		B		C		D		E		F		Drafhood Connector Diameter inches
	inches	(cm)	inches	(cm)	inches	(cm)	inches	(cm)	inches	(cm)	inches	(cm)	
UG40	54	(137)	47 3/4	(121)	22	(56)	13	(33)	8	(20)	41	(104)	3 or 4
UG50	55 3/4	(142)	49 1/2	(126)	24	(61)	13	(33)	8	(20)	42 1/2	(108)	3 or 4

All models are suitable for potable water and space heating applications.

Toxic chemicals, such as those used for boiler treatment, must NEVER be introduced into this system.

This unit must NEVER be connected to any existing heating system or component(s) previously used with a non-potable water heating appliance.

### WARRANTY

**6 years**

against inner tank  
leakage

**6 years**

on component parts

Giant offers a SIX (6)\* year limited warranty against inner tank leakage on residential atmospheric vent water heaters from the date of installation and a SIX (6)\* year limited warranty on component parts. For specific warranty details including exceptions, consult the owner's manual provided with each water heater.

\*When installed by a professional.

# Giant<sup>®</sup>

11021, Notre-Dame Street East, Montreal-East, Quebec, Canada, H1B 5H3

Telephone : 514-645-8893 • Toll free : 1-800-363-9354

General fax : 514-640-0969

Customer Service fax : 514-645-8413

[giantinc.com](http://giantinc.com)