



# Giant®

Enhancing everyday living

RESIDENTIAL  
**STORAGE TANKS**

| 30 | 40 | 60 | IMP. GALLONS

# ANTICIPATE THE NEEDS OR YOUR FAMILY

When selecting your storage tank, optimize your comfort and choose a potable water or space heating application. These storage tanks are ideal for modern households that require larger volumes of hot water for multiple full bathrooms, multi shower head systems, extra-large bathtubs or whirlpools, spas, etc.

## BENEFITS

### 1 - HIGH DEMAND APPLICATION

Available in 30, 40 and 60 Imp. Gallon, these tanks will store your hot water at a constant temperature no matter the intensity of your draws.

### 2 - HIGH QUALITY MAGNESIUM ANODE

Provides excellent protection against the corrosive effects of water and extends tank life.

### 3 - BRASS COMBINATION INLET DRAIN VALVE

A high quality one-piece brass combination inlet drain valve is installed for easy drainage and recirculation.

### 4 - FACTORY INSTALLED 3/4" NPT DI-ELECTRIC NIPPLES

Extend the life of the water heater by providing excellent corrosion protection.

### 5 - FACTORY INSTALLED T&P RELIEF VALVE

Protects the tank from the damaging effects of excessive temperature and pressure.

### 6 - GLASS-LINED INNER TANK

A uniquely formulated blue cobalt glass enriched with zircon is fused to specially treated steel at 1,600°F (871°C) to provide the best coating available against corrosion for many years. The tank is certified at a test pressure of 300 PSI (2,068 kPa) and a working pressure of 150 PSI (1,035 kPa).

### 7 - INSULATION

A thick uniform blanket blanket of insulation keeps the water hotter for longer periods, reduces standby losses and energy costs. It contains no HCFC'S (hydrochlorofluorocarbons), CFC'S (chlorofluorocarbons), HFC'S (hydrofluorocarbons) nor VOC's (volatile organic compounds).

### 8 - OVERFLOW SYSTEM

A 90° horizontal overflow elbow tube is supplied with each storage tanks.

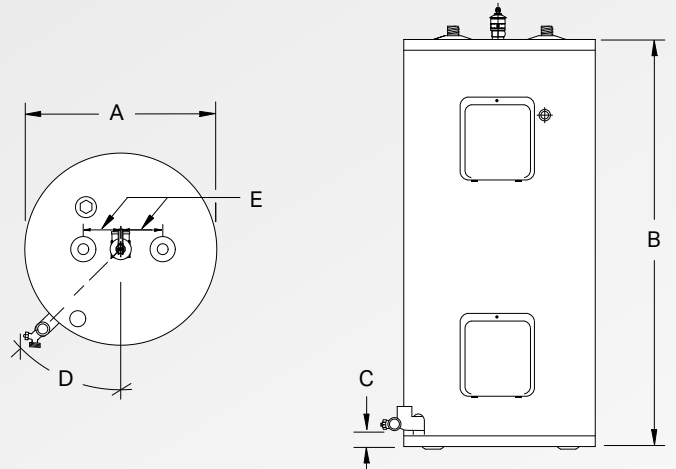

## SPECIFICATIONS & DIMENSIONS

| Models      | Storage Capacity |        |           | A      |      | B      |       | C      |      | D   | E      |      | Estimated shipping weight |      |
|-------------|------------------|--------|-----------|--------|------|--------|-------|--------|------|-----|--------|------|---------------------------|------|
|             | US gal.          | Litres | Imp. gal. | inches | (cm) | inches | (cm)  | inches | (cm) |     | inches | (cm) | lb                        | (kg) |
| 142ETE-9G7M | 34               | 130    | 29        | 22     | (56) | 36 1/4 | (92)  | 2 1/8  | (5)  | 45° | 4      | (10) | 115                       | (52) |
| 152ETE-9G7M | 49               | 184    | 41        | 22     | (56) | 49 1/4 | (125) | 2 1/8  | (5)  | 45° | 4      | (10) | 140                       | (64) |
| 172ETE-9G7M | 74               | 279    | 61        | 24     | (61) | 60     | (152) | 2 1/8  | (5)  | 45° | 4      | (10) | 185                       | (84) |

## WARRANTY

**5 years**

against inner tank leakage

**1 year**

on component parts

Giant offers a FIVE (5) year limited warranty against inner tank leakage from the date of installation on all residential storage tanks. They also benefit from a ONE (1) year limited warranty on component parts. For more specific warranty details including exceptions, consult the owner's manual provided with each tanks.

# Giant®

11021, Notre-Dame Street East, Montreal-East, Quebec, Canada, H1B 5H3  
 Telephone : 514-645-8893 • Toll free : 1-800-363-9354  
 General fax : 514-640-0969  
 Customer Service fax : 514-645-8413

[giantinc.com](http://giantinc.com)