



**Expert**  
+PLUS.



**Giant**<sup>®</sup>

Enhancing everyday living

RESIDENTIAL ELECTRIC WATER HEATERS

**EXPERT PLUS™  
BOTTOM ENTRY**

| 40 | 60 | IMP. GALLONS

# BENEFITS

## 1 - GLASS-LINED INNER TANK

A coating of a uniquely formulated blue cobalt glass enriched with zircon is fused to specially treated steel at 1,600°F (871°C) to provide the best coating available against corrosion for many years. The tank is certified at a test pressure of 300 PSI (2,068 kPa) and a working pressure of 150 PSI (1,034 kPa).

## 2 - MEDIUM DENSITY SCREW-IN TYPE ELECTRIC ELEMENTS

This model is equipped with medium density CSA approved screw-in type immersion elements.



## 3 - INSULATION

Two (2) inch (5 cm) thick uniform blanket of eco-friendly insulation keeps the water hotter for longer periods, reduces stand-by losses and energy costs. It contains no HCFC's (hydrochlorofluorocarbons), CFC's (chlorofluorocarbons), HFC's (hydrofluorocarbons) nor VOC's (volatile organic compounds).

## 4 - FACTORY INSTALLED 3/4" NPT DI-ELECTRIC NIPPLES

Extend the life of the water heater by providing excellent corrosion protection.

## 5 - SUPPLIED INSTALLATION KIT

Temperature & pressure-relief valve, 90° elbow overflow tube, and a brass "T" are supplied with each Expert Plus 8 water heater. The temperature & pressure-relief valve protects the tank from the damaging effects of excessive temperature and pressure.

## 6 - HIGH QUALITY MAGNESIUM ANODE

Provides superior corrosion prevention and extended tank life.

## 7 - BOTTOM ENTRY

Bottom cold water entry resulting in 10% more hot water instantly. A \$100 saving on your electricity bill (based on \$0.08/kWh, a ten (10) year life of the water heater and according to the average household consumption).

## 8 - BRASS DRAIN VALVE

Tamper resistant one-piece brass drain valve is installed for easy drainage.

## 9 - AUTOMATIC TEMPERATURE CONTROL

Adjustable thermostats will provide years of reliable trouble-free service at the desired water temperature and a safety cut-off is provided for abnormal conditions.

# Expert +PLUS™

## The Choice of Experts!

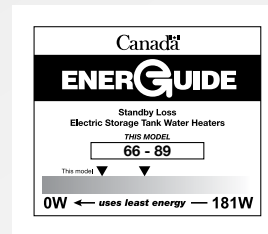
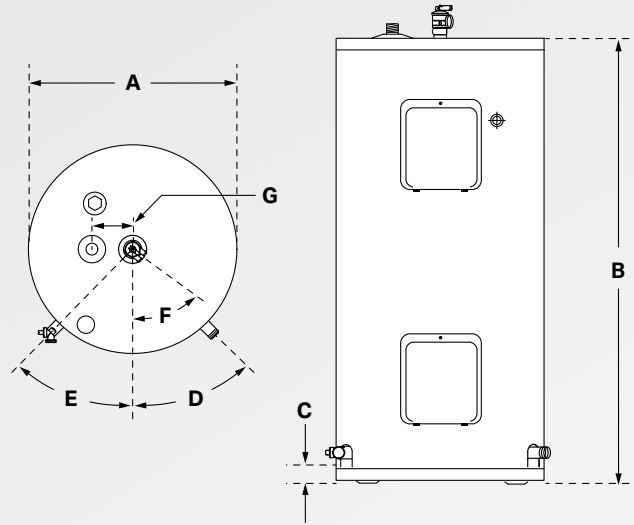

## SPECIFICATIONS & DIMENSIONS

Models	Storage Capacity			Voltage volts	Elements Input		Standby Loss watts	Diameter (A)		Height (B)		C		D	E	F	G		Est. Ship. Weight	
	US gal.	Liters	IMP gal.		watts	amp		inches	(cm)	inches	(cm)	inches	(cm)				inches	(cm)	inches	(cm)
152E-3S8M-E6	49	184	41	240	3,000	12.50	66	22	(56)	48	(122)	2 1/8	(5)	45°	45°	52°	4	(10)	140	(63)
172E-2S8M-E6	74	279	61	208	4,500	21.70	89	24	(61)	60	(152)	2 1/8	(5)	45°	45°	52°	4	(10)	197	(89)
172E-3S8M-E6	74	279	61	240	4,500	18.80	89	24	(61)	60	(152)	2 1/8	(5)	45°	45°	52°	4	(10)	197	(89)
172E-3S8M-E600	74	279	61	240	6,000	25.00	89	24	(61)	60	(152)	2 1/8	(5)	45°	45°	52°	4	(10)	197	(89)

Toxic chemicals, such as those used for boiler treatment, must NEVER be introduced into this system.

This unit must NEVER be connected to any existing heating system or component(s) previously used with a non-potable water heating appliance.

## WARRANTY

**6 years**

against inner tank leakage

**6 years**

on component parts

Giant offers a SIX (6) year extended warranty against inner tank leakage from the date of installation for all Expert Plus residential electric water heaters. A SIX (6) year extended warranty is also offered on component parts. For more specific warranty details including exceptions, consult the owner's manual provided with each water heater.

# Giant®

11021, Notre-Dame Street East, Montreal-East, Quebec, Canada, H1B 2V5

Telephone : 514-645-8893 • Toll free : 1-800-363-9354

General fax : 514-640-0969

Customer Service fax : 514-645-8413

[giantinc.com](http://giantinc.com)