

Storage Tank

Standards

- Meet CSA 22.2 construction standards
- Meet or exceed NRCAN energy efficiency standards

Benefits

- Available in 30, 40 and 60 Imp. gallon, these tanks will store your hot water at a constant temperature no matter the intensity of your draws
- High quality magnesium anode provides excellent protection against the corrosive effects of water and extends tank life
- A high quality one-piece brass combination inlet drain valve is installed for easy drainage and recirculation
- Factory installed 3/4" NPT di-electric nipples to extend the life of the water heater by providing excellent corrosion protection
- Factory installed T&P relief valve protects the tank from the damaging effects of excessive temperature and pressure

- Tank is glass-lined with blue cobalt, enriched with zircon fused to special steel at 1,600°F (871°C).
- A 90° horizontal overflow elbow tube is supplied with each storage tanks

Warranty

- 5-year warranty against inner tank leakage
- 1-year warranty on parts



Illustrated model: 152ETE-9G7M



Storage Tank

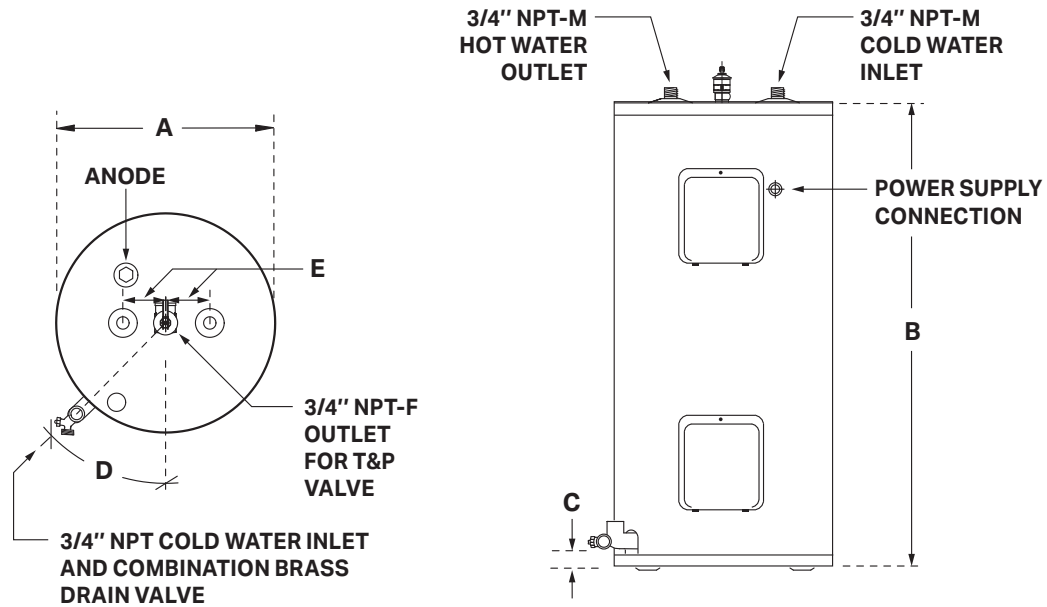

SPECIFICATIONS & DIMENSIONS

Model	Storage Capacity			Diameter (A) inches (cm)	Height (B) inches (cm)	C inches (cm)	D	E inches (cm)	Plumbing connections	Estimated shipping weight lb (kg)
	US gal.	liters	IMP gal.							
142ETE-9G7M	34	130	29	22 (56)	36 1/4 (92)	2 1/8 (5)	45°	4 (10)	3/4" NPT	115 (52)
152ETE-9G7M	49	184	41	22 (56)	49 1/4 (125)	2 1/8 (5)	45°	4 (10)	3/4" NPT	140 (64)
172ETE-9G7M	74	279	61	24 (61)	60 (152)	2 1/8 (5)	45°	4 (10)	3/4" NPT	185 (84)