



Enhancing everyday living



# ENGINEERING SUBMITTAL DATA SHEET

Commercial electric water heaters, Flexible

**108 MODELS (Light & Medium Duty)**

61 imperial gallons / 279 litres

Insulated with 2" Eco-Friendly **GREENFOAM**

**208, 240, 277 & 480 Volts / Single phase**

These models meet the safety and construction requirements of CSA Standard C22.2 No. 110 and meet or exceed the standby loss requirements of NRCan and ASHRAE 90.1 Standard.

Models*	Input (kW)	Amperage				Phase	Number of elements
		208 Volts	240 Volts	277 Volts	480 Volts		
<b>Light Duty (2 elements) &amp; Medium Duty (4 elements)</b>							
1082Y-1-3S	3	14.4	12.5	10.8	6.3	1	2
1082Y-1-4.5S	4.5	21.6	18.8	16.2	9.4		
1082Y-1-5S	5	24.0	20.8	18.1	10.4		
1082Y-1-6S	6	—	25.0	21.7	12.5		
1084Y-1-6S	6	28.8	25.0	21.7	12.5	1	4
1084Y-1-9S	9	43.3	37.5	32.5	18.8		
1084Y-1-10S	10	48.1	41.7	36.1	20.8		
1084Y-1-12S	12	—	50.0	43.3	25.0		

\* Replace the "Y" by the letter referring to its voltage (refer to the following "Voltage index" as well as the "Model Number Structure" for further details).

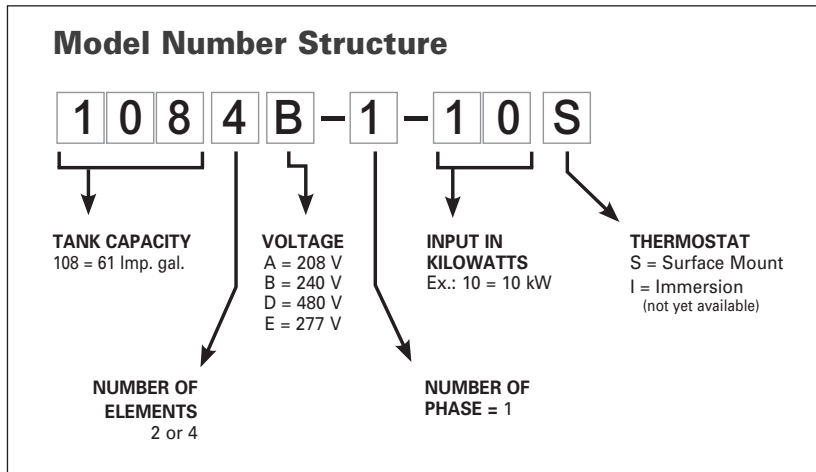

Voltage index	
A	208 Volts
B	240 Volts
D	480 Volts
E	277 Volts

Notes: \_\_\_\_\_

\_\_\_\_\_

\_\_\_\_\_

\_\_\_\_\_

\_\_\_\_\_

\_\_\_\_\_

\_\_\_\_\_

See reverse for this model drawing as well as order details.



In accordance with our company policy of on-going product improvement, Giant Factories Inc. reserves the right to make changes without prior notice.

[giantinc.com](http://giantinc.com)



40 Lesage Avenue, Montréal-East (Québec) Canada H1B 5H3 • Telephone: (514) 645-8893 • Fax: (514) 640-0969



Commercial electric water heaters, Flexible  
**108 MODELS**  
**(Light & Medium Duty)**  
 61 imperial gallons / 279 litres

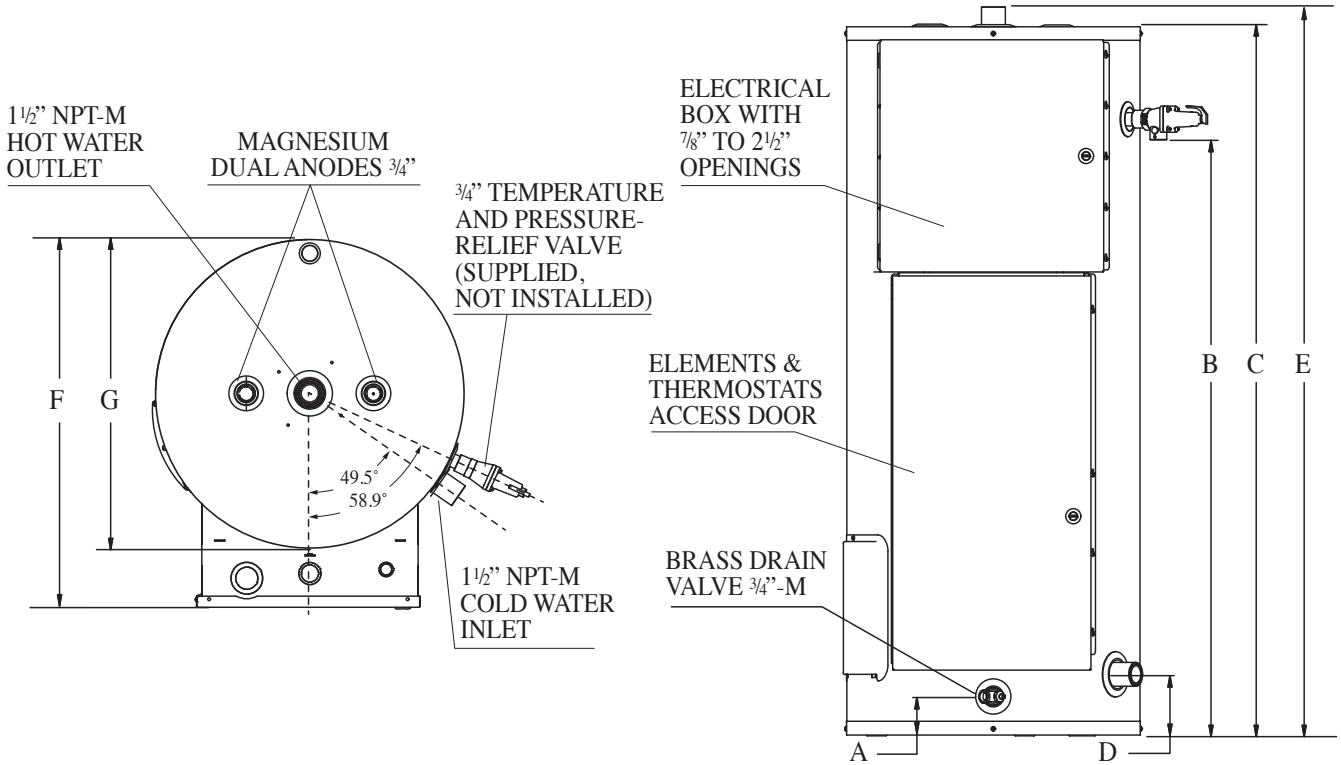

Models	Storage Capacity			A Inches (cm)	B Inches (cm)	C Inches (cm)	D Inches (cm)	E Inches (cm)	F Inches (cm)	G Inches (cm)	Est. Ship. Weight	
	Imp. gal.	Litres	U.S. gal.								lb.	kg
All 108	61	279	74	3 1/8 (7.9)	51 3/8 (130.5)	59 5/8 (151.4)	4 7/8 (12.4)	60 7/8 (154.6)	28 1/4 (71.8)	24 (61)	285	129.3

Notes: \_\_\_\_\_  
 \_\_\_\_\_  
 \_\_\_\_\_

JOB TITLE \_\_\_\_\_

SUBMITTED DATE \_\_\_\_\_

ADDRESS \_\_\_\_\_  
 \_\_\_\_\_

REQUIRED PRODUCT \_\_\_\_\_

CONTRACTOR \_\_\_\_\_

MODEL NO. \_\_\_\_\_ SIZE \_\_\_\_\_ QUANTITY \_\_\_\_\_

ADDRESS \_\_\_\_\_  
 \_\_\_\_\_

MODEL NO. \_\_\_\_\_ SIZE \_\_\_\_\_ QUANTITY \_\_\_\_\_

ENGINEER \_\_\_\_\_

MODEL NO. \_\_\_\_\_ SIZE \_\_\_\_\_ QUANTITY \_\_\_\_\_

MODEL NO. \_\_\_\_\_ SIZE \_\_\_\_\_ QUANTITY \_\_\_\_\_

REQUIRED DATE \_\_\_\_\_

In accordance with our company policy of on-going product improvement, Giant Factories Inc. reserves the right to make changes without prior notice.

[giantinc.com](http://giantinc.com)



40 Lesage Avenue, Montréal-East (Québec) Canada H1B 5H3 • Telephone: (514) 645-8893 • Fax: (514) 640-0969