

VOLTEX® AL SMART HYBRID ELECTRIC HEAT PUMP WATER HEATER WITH ANTI-LEAK TECHNOLOGY

The Voltex® AL Smart Hybrid Electric heat pump water heater from A. O. Smith is the most cost-effective, energy-efficient option available for consumers who want to save money on their utility bills. Voltex® AL combines annual savings on utility bills with new leak protection features to support homeowner peace of mind like leak detection and optional automatic water shutoff.

HOW DO THEY WORK?

Absorb ambient heat from the surrounding air to heat water using a compressor

- Self-contained heat pump unit is integrated into the top of the tank
- Backup electric elements can supplement the heat pump depending on operating mode, environmental conditions and hot water demand

EXCEPTIONAL ENERGY EFFICIENCY

- Improved efficiency up to 4.02 Uniform Energy Factor (UEF) can reduce the cost of water heating by up to 75%*
- Heat pump can work down to 2°C (37°F) ambient for more days of high efficiency operation
- ENERGY STAR® certified

iCOMM™ SMART CONNECTIVITY

- Monitor and control your water heater through the free A. O. Smith app
- Connect through a local Wi-Fi network or directly to the water heater through Bluetooth®
- Receive alerts and notifications

LEAK PROTECTION TECHNOLOGY

- Smart anode adapts to local water conditions to protect and extend the life of the water heater
- Controls regulate depletion of the anode to extend the life of the anode allowing superior tank protection far longer than standard anode rods
- User is notified when the anode is consumed and needs to be replaced
- Smart sensor alerts user in the event a leak does occur for added peace of mind
- Automatic water shutoff compatible for enhanced protection (accessory kit **100345338**)
- Notifications through iCOMM™ function on the A. O. Smith app

QUIET OPERATION

- Whisper-quiet operation at 45 dBA

FLEXIBLE DESIGN

- Top and front water connections for easy installation
- Zero clearance required on sides and back to fit in tighter spaces
- Integrated ducting adapters for installations in confined spaces
- Ideal for basements, utility rooms or garage installations; the compressor transfers heat to the water while dehumidifying and cooling the ambient air

ELECTRONIC CONTROLS

- User-friendly electronic interface allows easy control of temperature, operating mode and diagnostics

10-YEAR LIMITED WARRANTY

- For complete information, consult written warranty or go to hotwatercanada.ca



*Comparing 80-gallon Voltex AL heat pump against pre-2015 similarly-sized standard electric using DOE EF to UEF conversion rates and \$0.14 per kWh electricity cost. Savings may vary.

Model	Capacity		UEF	First Hour Rating	Dimensions in (cm)							Approx. Shipping Weight lb (kg)
	USG	L			USG (L)	A	B	C	D	E	F	
HPTS-50	50	189	3.80	65 (246)	63 (160)	22 (56)	40 ½ (103)	3 ¾ (9.5)	8 (20)	43 ½ (136)	48 (122)	196 (89)
HPTS-66	66	250	4.02	82 (310)	61 ½ (156)	26 ½ (67)	38 ¼ (97)	4 (10)	8 (20)	41 ¼ (105)	46 (115)	284 (129)
HPTS-80	80	303	3.88	95 (360)	69 (175)	26 ½ (67)	46 ½ (118)	4 (10)	8 (20)	50 ½ (128)	54 ½ (138)	302 (137)

Requires 30 amp breaker.
Top T&P option not available.

MULTIPLE OPERATING MODES

Choose from multiple modes to match water heating needs and environmental conditions

- Hybrid (Default): Hot water delivery balanced with energy saving performance
- Heat Pump: Maximum energy efficiency
- Electric: Uses only the electric heating elements
- Vacation: Reduce energy use while you are away

iCOMM™ SMART CONNECTIVITY

Download the free A. O. Smith app to get started.



OTHER FEATURES:

- Easily accessible front mounted junction box
- Environmentally-friendly, non-CFC foam insulation
- Durable, enhanced-flow brass drain valve
- CSA certified and ASME rated temperature & pressure relief valve

OPERATING REQUIREMENTS:

- Requires provision for non-acidic condensate draining; if a suitable drain is not available a condensate pump is required
- 208/240VAC 4500/3380W 50/60 Hz single phase 30 amp power supply

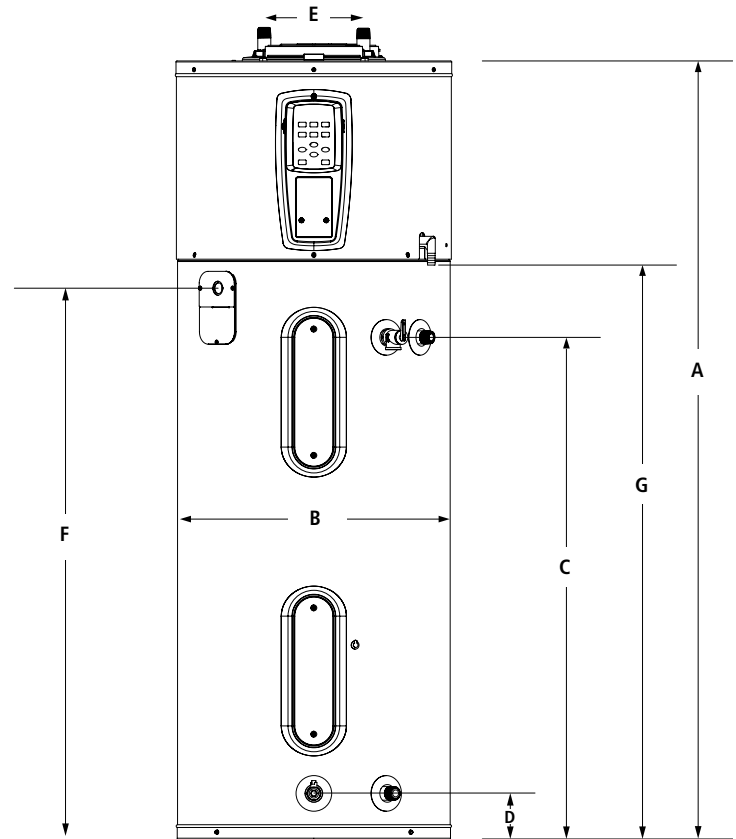

Apple logo and Apple App Store Logo are trademarks of Apple Inc.
Google Play and the Google Play logo are trademarks of Google LLC.

450 FT³ ENCLOSED ROOM SIZE IS 35% SMALLER THAN OTHER MANUFACTURERS REQUIRE

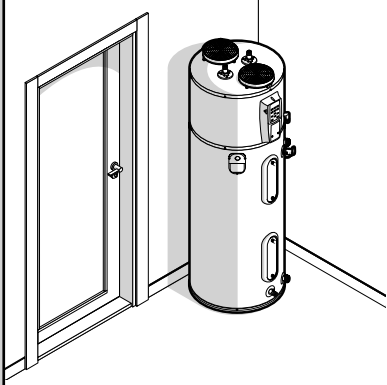
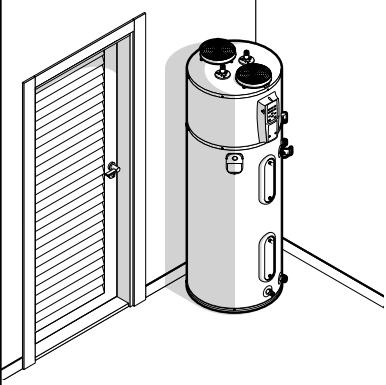
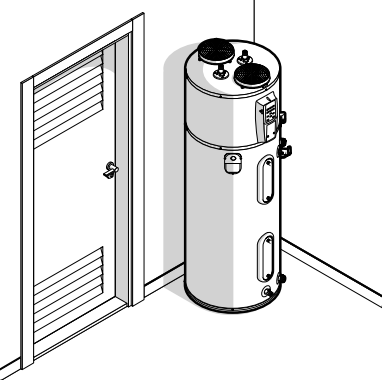
			
Configuration	Enclosed Room	Fully Louvered Door	Upper and Lower Louvers in Door ^{1,2}
Minimum Space (FT³)	450	84	84
Space Example L x W x H (FT)	6 x 7.5 x 10	3 x 2.8 x 10	3 x 2.8 x 10

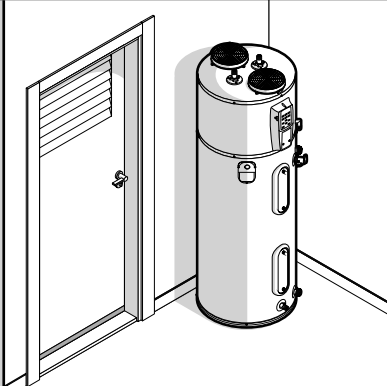
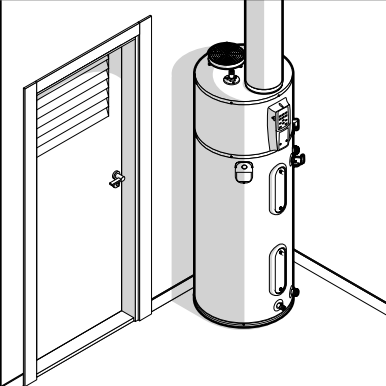
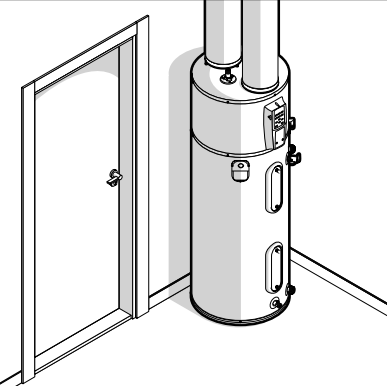
			
Configuration	Upper Louver and Undercut Door ^{1,3,4}	Inlet OR Outlet Ducting and a Single Louver OR Undercut Door ^{1,3,4,5}	Inlet AND Outlet Ducting ⁵
Minimum Space (FT³)	84	No minimum space requirement	No minimum space requirement
Space Example L x W x H (FT)	6 x 7.5 x 10		

¹Minimum louver size is 130 in² free area each.

²When two louvers are installed, install one louver at the top of the heater and the other close to the floor.

³Undercut door should have a minimum of 0.75" clearance. (minimum 18 in² air gap)

⁴When one louver is installed, install the louver in a location close to the top of the heater.

⁵This heater supports multiple duct diameters as well as rigid and flex ducting options. See manual for more information.

For Technical Information, call 888-599-2837. A. O. Smith Enterprises Ltd. reserves the right to make product changes or improvements without prior notice.