

## ADAPT® SC Standard Condensing Tankless with X3™ Scale Prevention Technology

Introducing ADAPT® SC standard condensing gas tankless water heaters, delivering robust, on-demand performance and the flexibility to install in practically any residential setting.

### X3™ SCALE PREVENTION TECHNOLOGY (PATENTED DESIGN)

- Units maintain like-new performance longer and life extended by up to 3x versus unprotected units
- Eliminates need for annual descaling
- Additional X3™ cartridges available for purchase with accessory parts

### PERFORMANCE & EFFICIENCY

- 199,000 BTU/h
- 10,000 BTU/h min. input
- Max Flow Rate 10.5 GPM; 0.4 GPM activation; 0.26 GPM for continuous fire
- 0.95 UEF, ENERGY STAR® certified
- Ultra Low NOx

### ULTIMATE FLEXIBILITY EASE OF INSTALLATION

- Vent with ULC S636 certified PVC, CPVC, or polypropylene pipe
- Exhaust venting, 2" PVC up to 50' (15.3 m); 3" PVC up to 150' (45.7 m)
- Flexible venting with PVC, CPVC or Polypropylene
- Pressure relief valve included with X3™ models
- Cascade up to 12 units with single cable per heater, cable included
- Approved for installation in manufactured homes

### LIMITED WARRANTY

- No hardwater exclusions on X3™ models
- 15-year limited warranty on heat exchanger in residential applications
- 5-year limited warranty on all parts in residential applications
- 1-year limited warranty on heat exchanger and parts in commercial applications



**GTM-199X3-N**  
**GTM-199X3-P**

with Integrated X3™ Scale Prevention Technology



CSA/ANSI Z21.10.3 • CSA 4.3



# Residential Gas Tankless Water Heaters

## Specifications - ADAPT® SC Standard condensing Tankless with X3™ Scale Prevention Technology

		GTM-199X3-N	GTM-199X3-P
<b>Installation Type</b>		Indoor	
<b>X3™ Scale Prevention Technology</b>		Integrated	
<b>Gas Consumption Input</b>	<b>Min. BTU/H</b>	10,000	
	<b>Max. BTU/H</b>	199,000	
<b>Fuel Type</b>		Natural Gas	Propane
<b>Heat Exchangers</b>		Primary Copper, Secondary Stainless Steel	
<b>Uniform Energy Factor (UEF)</b>		0.95	
<b>Maximum GPM*</b>		10.5 GPM	
<b>Activation GPM</b>		0.4 GPM	
<b>Continuous Fire GPM</b>		0.26 GPM	
<b>Water Pressure Min. - Max.</b>		15- 150 PSI (40 PSI Recommended for Maximum Flow)	
<b>Supply Gas Pressure</b>	<b>Min. in W.C. (kPa)</b>	4.0 (1.0)	8.0 (2.0)
	<b>Max. in W.C. (kPa)</b>	10.5 (2.6)	14.0 (3.49)
<b>Hot/Cold Connections</b>		3/4" NPT	
<b>Gas Connection</b>		3/4" NPT	
<b>Temperature Settings Min. - Max.</b>		100°F (38°C)- 140°F (60°C); Default 120°F (49°C)	
<b>Ignition System</b>		Electronic Ignition	
<b>Power Supply</b>		120V, 50Hz/60Hz, <5A	
<b>Sound Level</b>		51 dB**	
<b>Elevation</b>		Certified from Sea Level to 7,800' (2,377.4 m)	
<b>Freeze Protection†</b>		- 5°F (-21°C)	
<b>Venting - Exhaust, Intake</b>	<b>Type</b>	Power Direct Vent	
	<b>Size, Max Run</b>	2", 50' (5.08 cm, 15.3 m); 3", 150' (7.6 cm, 45.7 m)	
	<b>Material</b>	PVC, CPVC or Polypropylene	
<b>Dimensions - Unit</b>	<b>Height***</b>	40.4" (102.6 cm)	
	<b>Width</b>	17.1" (43.5 cm)	
	<b>Depth</b>	11.9" (30.1 cm)	
	<b>Weight</b>	83 lb. (37.7 kg)	
<b>Dimensions - Shipping†</b>	<b>Height</b>	17.4" (44.2 cm)	
	<b>Width</b>	22.1" (56.2 cm)	
	<b>Depth</b>	39.25" (99.7 cm)	
	<b>Weight</b>	93 lb (42.2 kg)	

All models are ENERGY STAR® certified.

\*Current numbers based on factory settings.

\*\*Measured in an anechoic chamber.

\*\*\*Height with required cartridge installed; X3™ models with Scale Control Media cartridge. From flue collar to tip of cartridge.

†Packaged and shipped on unit back.

+Internal freeze protection for heater only; X3™ cartridge requires anti-freeze kit sold separately

Included with Heater: Manual, Pressure Relief Valve, Wall Mounting Bracket and Hardware, Vent Port Screws, Cascading Cable, Bird Screens



# Residential Gas Tankless Water Heaters

## Dimensions - ADAPT® SC Standard condensing Tankless with X3™ Scale Prevention Technology

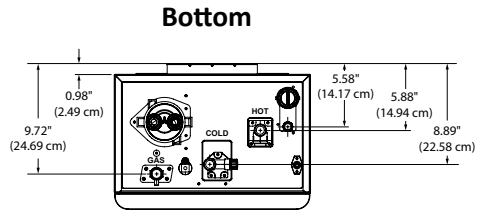
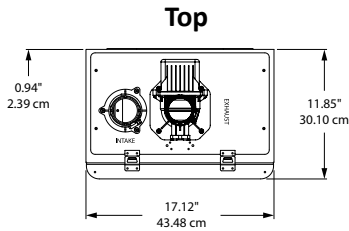
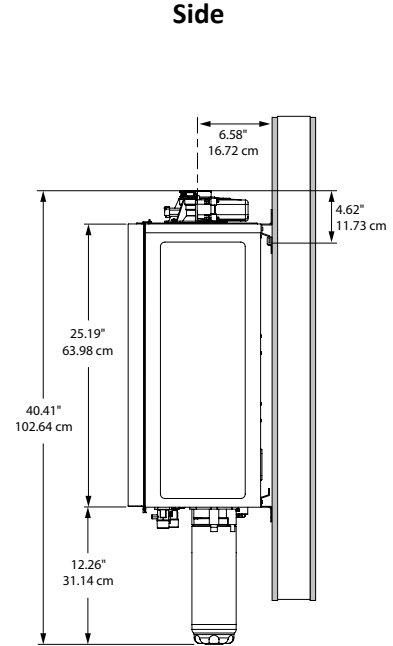
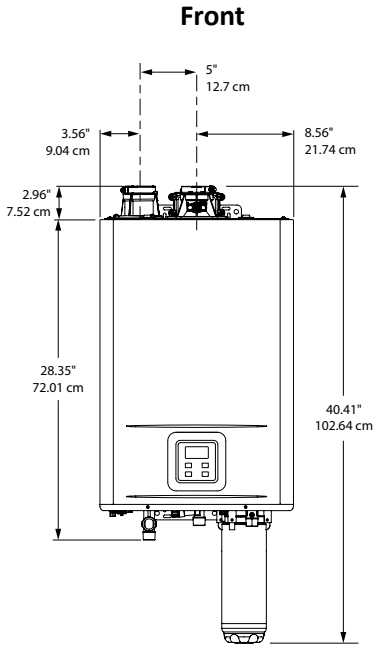

**TM Flow Rate Capacity**

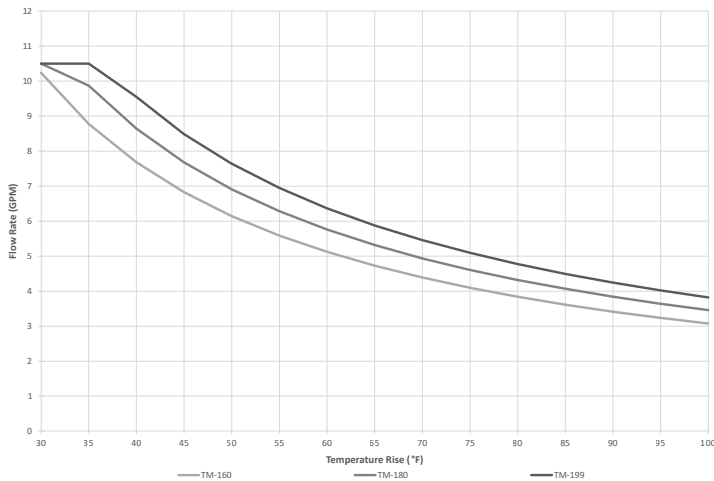



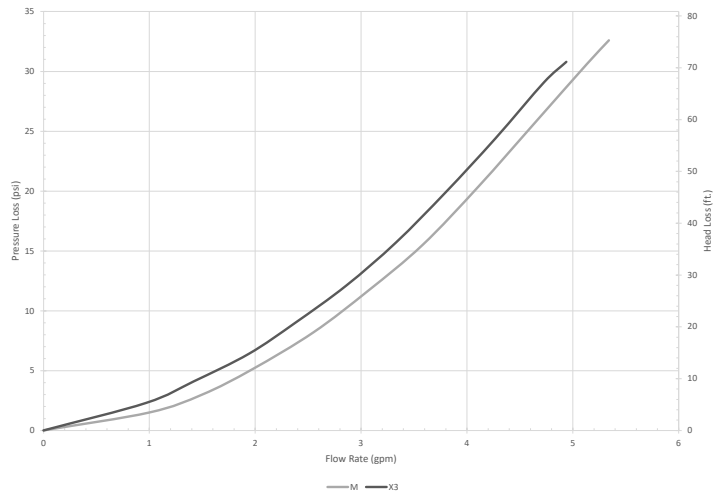

**Pressure Loss**



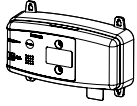
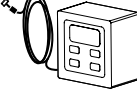

# Residential Gas Tankless Water Heaters

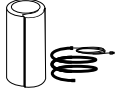
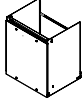
## Accessories - ADAPT® SC Standard condensing Tankless with X3™ Scale Prevention Technology

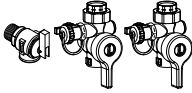
Item	Material Number		Description
Wi-Fi Module Kit	100371922		Wi-Fi Module for electronically connecting tankless water heaters to the internet and adapter to connect to the water heater. <ul style="list-style-type: none"><li>• Module (1x)</li><li>• Cable (1x)</li><li>• Adapter (1x)</li></ul>
Remote Temperature Controller	100383909		Remote Temperature Controller with 10' (3 m) cable.
Communication Cable - 10' (3 m)	100377341		Replacement Communication Cable for Remote Temperature Controller or WIFI Module, or On-Demand Receiver, 10' (3 m).
Communication Cable - 32' (10 m)	100377342		Extended Communication Cable for Remote Temperature Controller or WIFI Module, or On-Demand Receiver, 32' (10 m).
X3™ Freeze Protection (X3™ Models)	100325654		X3™ Cartridge Freeze Protection can add an extra layer of freeze protection to external SCM cartridge. Cartridge not protected by heater's internal freeze protection.
Pipe Cover	100383908		Pipe Cover protects plumbing connections to the heater while improving the appearance of the installation. Affixes to bottom of heater.
Neutralizer Assembly Kit	100112159		Neutralizer Assembly neutralizes the condensate (acidic water) that forms in the heat exchanger of the water heater. It connects to the condensate drain port of the water heater by using connectors included with the neutralizer kit.
Isolation Valve Kit with Pressure Relief Valve	100112156		Isolation Valve supports routine maintenance and allows for draining and flushing the heater; whereas, the Pressure Relief Valve, as the name implies, serves to limit internal pressure in the system. Not necessary for X3™ models. Check local codes for applicability.