



Instructions for Use

EvoEndo Model LE Single-Use Gastroscope and EvoEndo Controller (EE-C)

Rx ONLY For use by trained physicians only. For in-hospital use.

**EVOENDO SINGLE-USE
ENDOSCOPY SYSTEM**







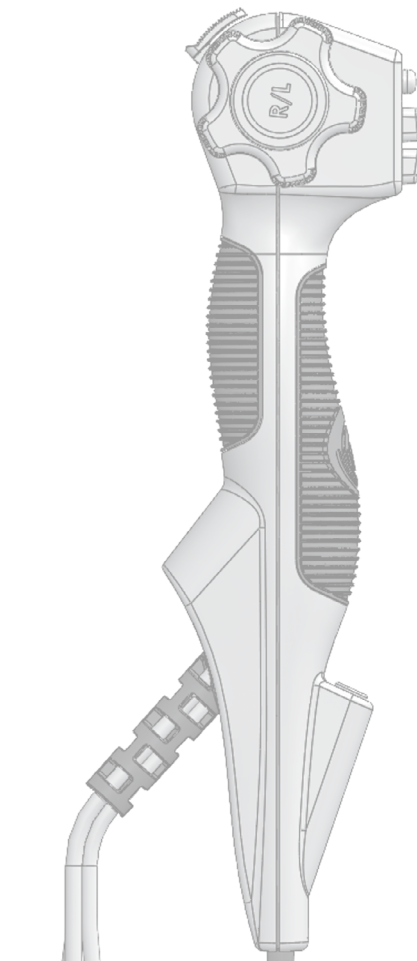





EvoEndo Inc.











EvoEndo Inc.®
888 East Belvidere Road, Suite 212
Grayslake, IL 60030
303.223.7445
www.evoendo.com

LBL-72 Rev. 8.0



SYMBOLS USED

Sterile product, sterilization by ETO	
Single-use product, do not reuse	
Single-use product, do not re-sterilize	
Warning	
Consult Instructions for Use	
Do not use if the product sterilization barrier or its packaging is damaged	
Single sterile barrier system	
Keep dry	
Keep away from sunlight	
Only for indoor use	
Reference number	
Lot number, batch code	
Serial number	
IP30 – Protection against solid objects	IP30

DVI output signal utilizing HDMI connector	HDMI
Use by	
Max OD (3.5 mm)	 Max OD
Field of view (120 degrees)	
Video connection for the EvoEndo Endoscope	
Direct current	
Alternating current	
Symbol of Class II equipment	
Electrical safety type BF applied part	
Tested to comply with FCC standards – Medical Equipment	
Waste Bin symbol, indicating that waste must be collected according to local regulation and collection schemes for disposal of electronic and medical waste.	
Potential equalization (equipotential)	
Caution: Federal law restricts this device to sale by or on the order of a physician.	Rx ONLY

CONTENTS

1. Important Information – Read Before Use	2
2. System Parts	4
3. Use Overview	8
4. System Setup	9
5. EvoEndo Model LE Single-Use Gastroscope Operation	11
6. EvoEndo Controller (EE-C) Operation	15
7. Cleaning of EvoEndo Controller and EvoEndo Gastroscope Reusable Video Cable	16
8. Troubleshooting	17
9. Technical Specifications	18
Appendix 1. Electromagnetic Compatibility	21
Appendix 2. Standards Applied	24
Appendix 3. Security	25
Appendix 4. Warranty and Replacement Program	25

1. Important Information – Read Before Use

NOTE: Read these safety instructions carefully before using the EvoEndo Single-Use Endoscopy System. The Instructions for Use may be updated without further notice. Copies of the current version are available online and upon request.

WARNING: *EvoEndo Model LE Gastroscope is a single-use device and must be handled in a manner consistent with accepted medical practice to avoid contamination prior to insertion.*

WARNING: *EvoEndo Single-Use Endoscopy System images must not be used as a single-point of diagnosis. Physicians must interpret and substantiate any finding by additional means and with reference to the patient's clinical characteristics.*

1.1. Instructions

Please be aware that these instructions do not explain or discuss clinical procedures. They describe only the basic operation and precautions related to the operation of the EvoEndo Single-Use Endoscopy System. Before initial use of the EvoEndo Single-Use Endoscopy System, it is essential for operators to have received sufficient training in clinical endoscopic techniques and to be familiar with the intended use, warnings, cautions, notes, indications, and contraindications mentioned in these instructions.

1.2. Intended Use / Indications for Use

The EvoEndo Model LE Gastroscope is intended for the visualization of the upper digestive tract in adults and pediatric patients, specifically for the observation, diagnosis, and endoscopic treatment of the esophagus, stomach, and duodenal bulb. The gastroscope is a sterile single-use device and can be inserted orally or transnasally. The 110 cm gastroscope is intended to be used in adult and pediatric populations. The 85 cm gastroscope is intended to be used in the pediatric population.

The EvoEndo Controller is intended for use with an EvoEndo Endoscope for endoscopic diagnosis, treatment, and video observation.

1.3. Intended Use Conditions

The EvoEndo Single-Use Endoscopy System is for use in a medical inpatient or outpatient environment.

Endoscopic diagnostic and non-active therapeutic accessories designed for a minimum working channel width of up to 2.0 mm can be used with the EvoEndo Single-Use Endoscopy System.

1.4. Warnings, Cautions, and Notes

Throughout these instructions, appropriate warnings, cautions, and notes are given describing potential safety hazards associated with the use of the EvoEndo Single-Use Endoscopy System.

There is no guarantee that instruments selected solely using this minimum instrument channel width will be compatible in combination.

WARNING: *Alerts the user to the possibility of injury, death, or other serious adverse reactions associated with the use or misuse of the EvoEndo Single-Use Endoscopy System.*

CAUTION: Alerts the user to the possibility of a problem with the EvoEndo Single-Use Endoscopy System associated with its use or misuse. Such problems include EvoEndo Single-Use Endoscopy System malfunction, EvoEndo Single-Use Endoscopy System failure, damage to the EvoEndo Single-Use Endoscopy System, or damage to property.

NOTE: Advises owner/operator about important information on the use of this device.

GENERAL WARNINGS

Do not use the EvoEndo Single-Use Endoscopy System if it is damaged in any way.

Perform a functional check before using the EvoEndo Single-Use Endoscopy System (see section 4). Do not use the EvoEndo Single-Use Endoscopy System if any part of the functional check fails.

Do not attempt to clean and reuse the EvoEndo Endoscope on another patient as it is a single-use device.

The EvoEndo Single-Use Endoscopy System is to be used with caution when delivering highly flammable anesthetic gases to the patient. This could potentially cause patient injury.

The EvoEndo Single-Use Endoscopy System is neither MRI-safe nor MRI-compatible.

Do not use the EvoEndo Single-Use Endoscopy System during defibrillation.

When handling the patient, do not simultaneously touch the EvoEndo Controller power socket and docking connector.

The EvoEndo Single-Use Endoscopy System should only be used by medical professionals trained in clinical endoscopic techniques and procedures.

Excessive force should never be used when operating the EvoEndo Single-Use Endoscopy System. Patients should be adequately monitored at all times during use.

Always watch the live endoscopic image when advancing or withdrawing the Scope, operating the endoscope tip, or suctioning. Failure to do so may harm the patient.

The EvoEndo Single-Use Endoscopy System may cause interference or disrupt equipment operations nearby. It may be necessary to adopt procedures for mitigation, such as reorientation or relocation of the equipment or shielding of the room in which it is used.

Do not use active endoscopic accessories such as laser probes or electrosurgical equipment in conjunction with the EvoEndo Single-Use Endoscopy System, as this may result in patient injury or damage to the EvoEndo Single-Use Endoscopy System.

The EvoEndo Single-Use Endoscopy System should be used with caution in oxygen-rich environments as it may potentially cause patient injury.

The EvoEndo Single-Use Endoscopy System should only be used with the Ferric HDMI cable provided with the device.

GENERAL CAUTIONS

Be careful not to damage the shaft or tip when using sharp devices such as needles in combination with the EvoEndo Single-Use Endoscopy System.

Be careful when handling the distal tip of the insertion tube and do not allow it to strike other objects, as this may result in damage to the equipment. The lens surface of the distal tip is fragile and visual distortion may occur.

Do not exert excessive force on the endoscope tip as this may result in damage to the equipment.

US federal law restricts these devices for sale only by or on the order of a physician.

Keep the EvoEndo Single-Use Endoscopy System handle dry during preparation and use.

Portable electronic equipment, except for tested accessories, may affect the normal function of the EvoEndo Single-Use Endoscopy System.

Physicians should assess and determine the appropriate length gastroscope based on the size of the patient and procedure to be performed prior to use.

GENERAL NOTES

Have a suitable backup system readily available for immediate use so the procedure can be continued if a malfunction should occur. EvoEndo is not responsible for any damage to the system or patient resulting from incorrect use.

The EvoEndo Model LE Single-Use Gastroscope is not made with natural rubber latex.

2. System Parts

Before you install and use the system, please ensure that the following EvoEndo items are available:

- EvoEndo Model LE 110 Single-Use Gastroscope – Part Number 1001
- EvoEndo Model LE 85 Single-Use Gastroscope – Part Number 1021
- EvoEndo Controller (EE-C) – Part Number 1002
- Medical-Grade Power Supply – Part Number 1003
- EvoEndo Instructions for Use – Part Number 1000
- Ferric HDMI Cable – Part Number 1004
- EvoEndo Gastroscope Reusable Video Cable (EE-RVC) – Part Number 1009

You will also need (not supplied by EvoEndo):

- Medical-Grade Monitor (minimum size recommended is 27", 1080p HD resolution)

The EvoEndo Single-Use Endoscopy System consists of a sterile single-use EvoEndo Endoscope, nonsterile reusable EvoEndo Video Cable, and reusable Controller (EE-C).

WARNING To avoid the risk of cross-contamination relating to the reusable electronic components, ensure EE-C is cleaned using appropriate cleaning solutions to meet hospital cleaning procedures.

2.1. EvoEndo Model LE Single-Use Gastroscope

2.1.1 Packaged System

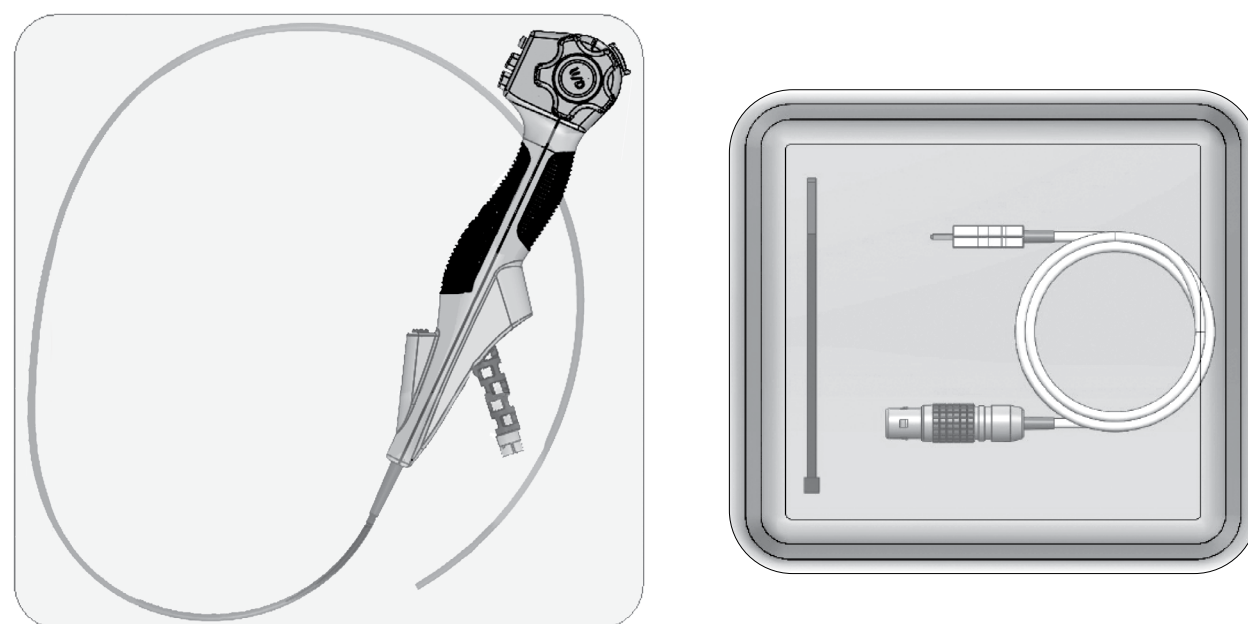

2.1.2 Device Overview and Connections

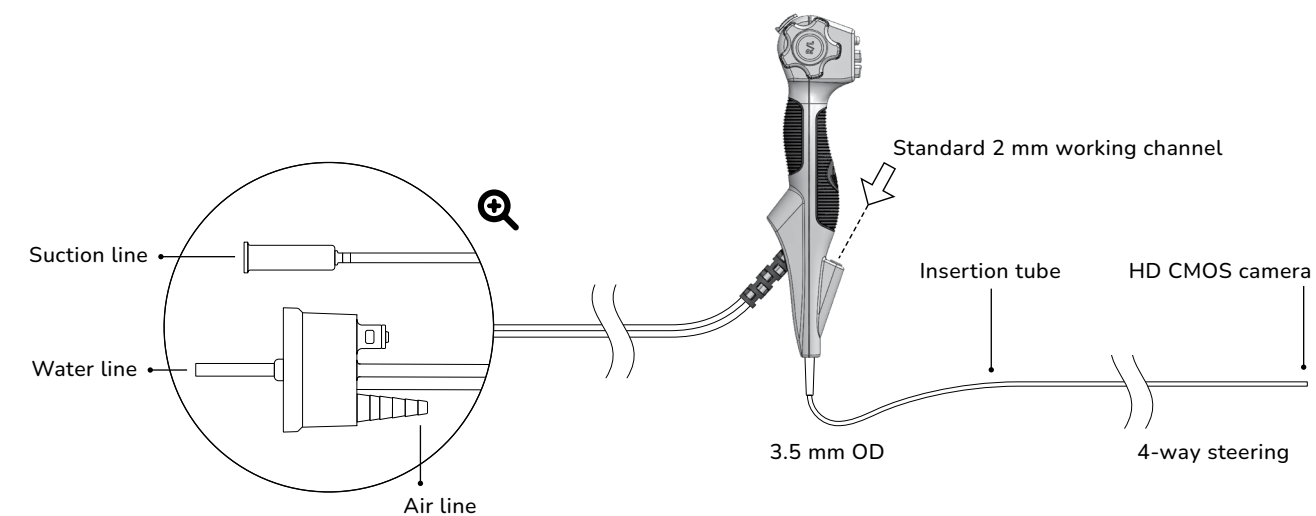

2.1.3 Handle Features

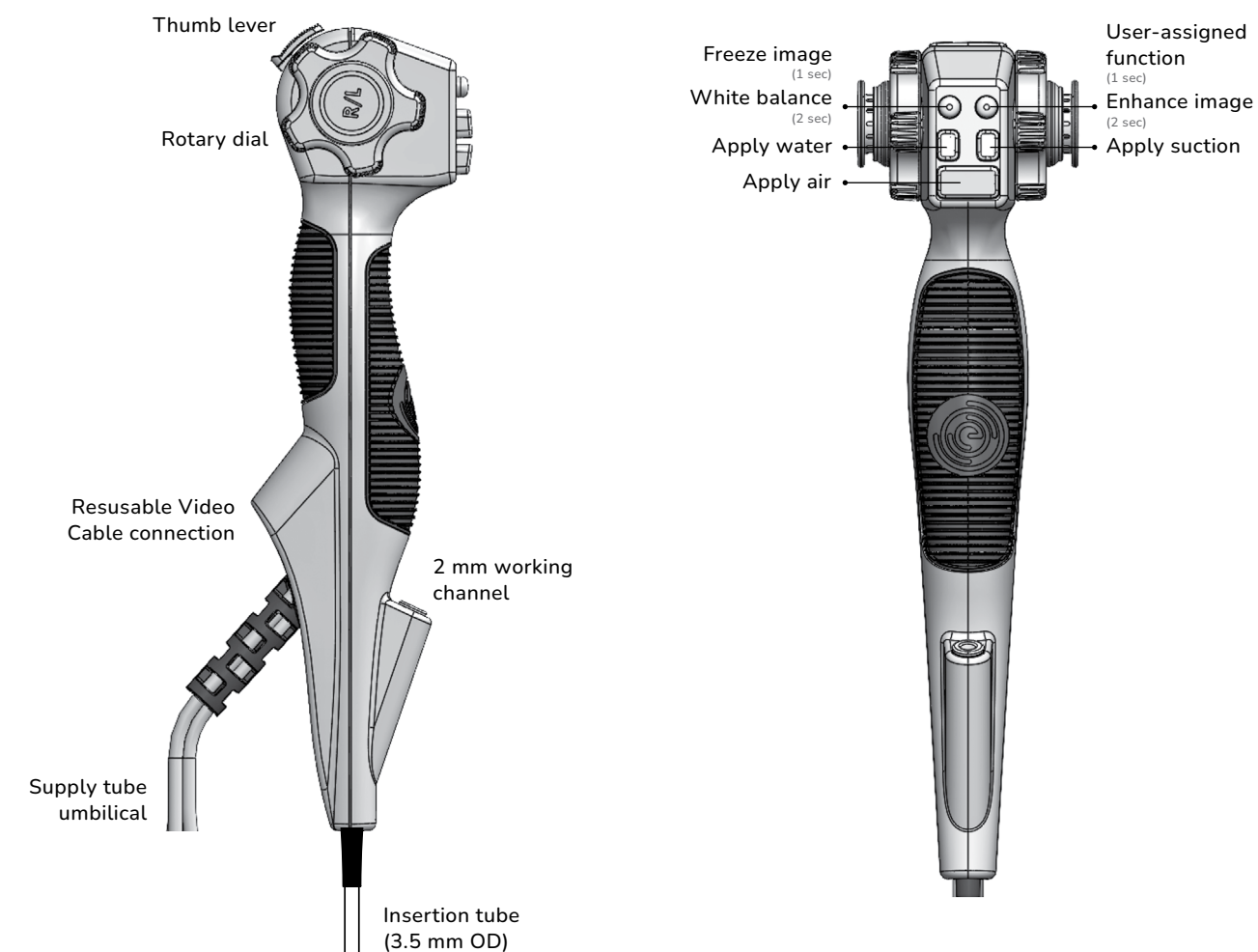

2.1.4 Tip Steering Controls

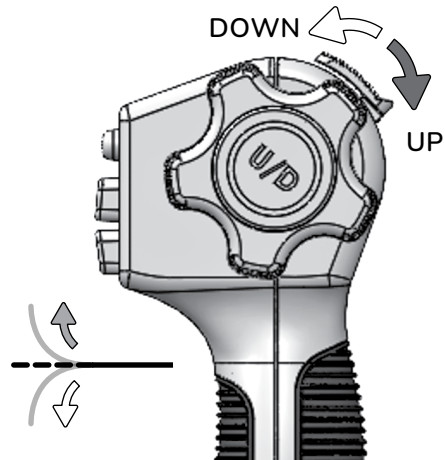

Thumb lever down = Tip up
Thumb lever up = Tip down

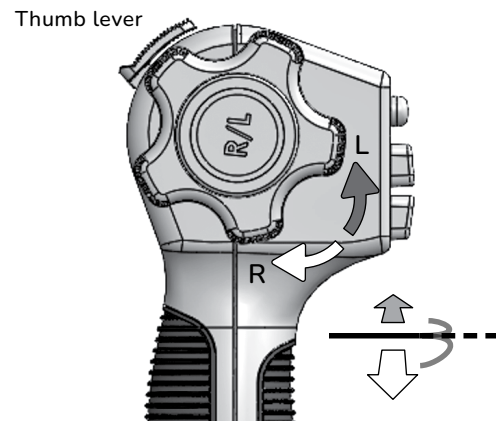

Rotary dial towards = Tip left
Rotary dial away = Tip right

2.1.5 Steering Support System Controls

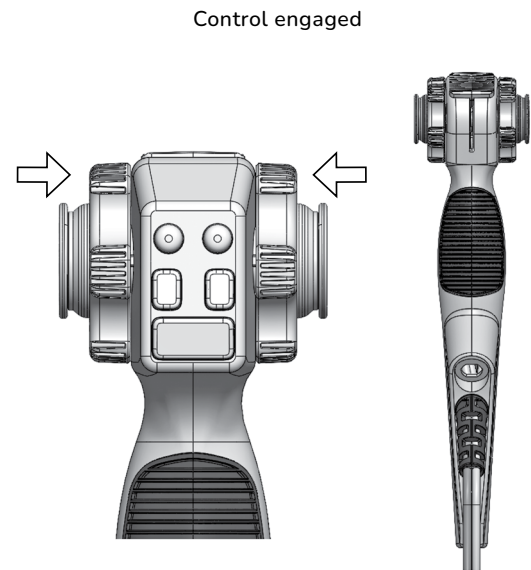
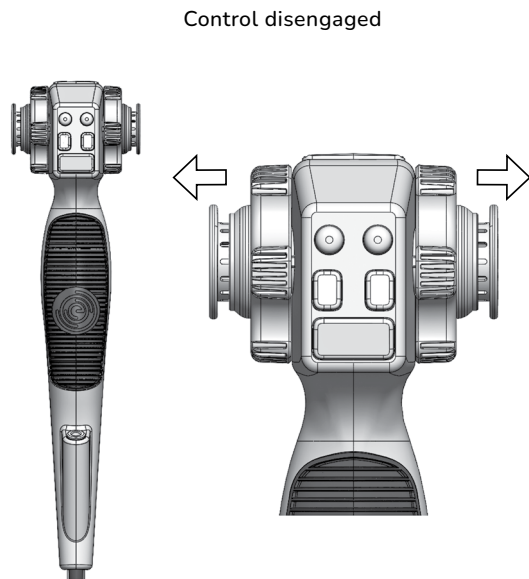

2.2. EvoEndo Controller (EE-C)

The EvoEndo Controller (EE-C) processes the live image feed from the EvoEndo Endoscope. The device uses standard 110V wall power via the power supply included. It contains an HDMI port for direct output to a medical-grade monitor and a USB 3.0 port for connection to third-party software systems. The EvoEndo Endoscope video connector plugs into the EvoEndo Reusable Video Cable that then connects to the EvoEndo Controller.

NOTE: Place on a secure table or cart away from water.

NOTE: When ON, a green LED will illuminate.

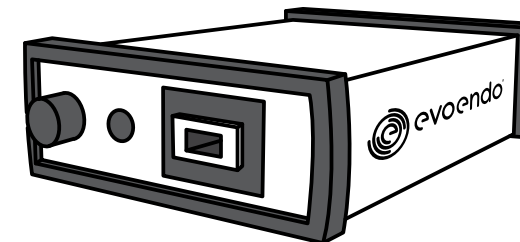

2.2.1 Controller Front

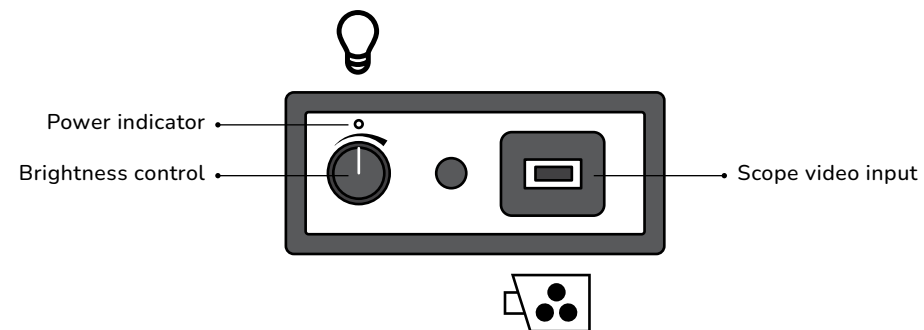

2.2.2 Controller Rear

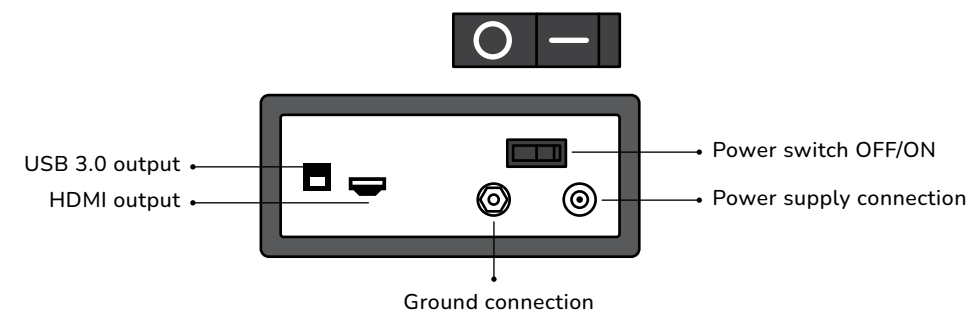

2.3. EvoEndo Controller Power Supply

This power supply is fitted with a country-specific plug and powers the EE-C only.

3. Use Overview

3.1. Unpack and Inspect

- ❑ Device packaging not damaged?
- ❑ Device free from defects and not damaged during unpacking?
- ❑ Controller and Reusable Video Cable cleaned from previous use?

3.2. Connect and Test

- ❑ Can make appropriate electrical connections?
- ❑ Image quality sufficient?
- ❑ Can make appropriate tube/supply connections?
- ❑ Successfully ID buttons for air/water/suction?
- ❑ Air/water/suction functioning correctly?
- ❑ Successfully ID buttons for freeze image, white-balance, and enhance image?
- ❑ Visually checked vertical tip control (thumb lever)?
- ❑ Visually checked horizontal tip control (rotary dial)?
- ❑ Endoscopic accessories fit the working channel?

3.3. Perform Endoscopic Procedure

3.4. Withdraw, Dispose, and Clean

- ❑ Remove any endoscopic accessories
- ❑ Discard Scope
- ❑ Recycle plastic and cardboard packaging
- ❑ Clean Controller and Reusable Video Cable

4. System Setup

WARNING: Do not use the EvoEndo Endoscope if it is damaged in any way or if any part of the functional check described below fails.

WARNING: Do not use a knife or sharp instrument to open the pouch or cardboard box.

CAUTION: The EvoEndo Single-Use Endoscopy System consists of the parts described in Section 2. They may only be replaced by EvoEndo authorized parts. Failure to comply with this may reduce safety and efficiency.

NOTE: Have a suitable backup system readily available for immediate use so the procedure can be continued if a malfunction should occur.

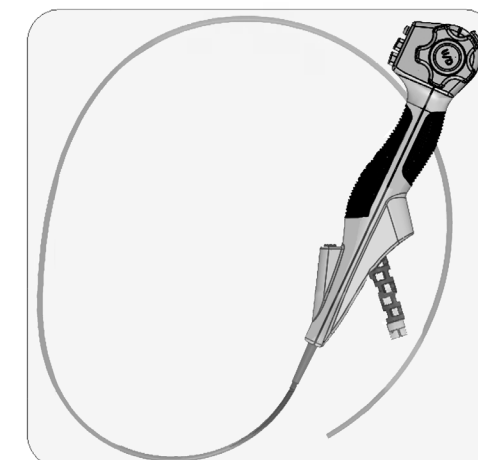

4.1. Inspect the EvoEndo Endoscope

- 4.1.1. Check that the pouch is not damaged and that the seal is intact.
- 4.1.2. Unpack the device and check that there are no impurities on the product.
- 4.1.3. Check that there is no evidence of shipping damage or other damage such as rough surfaces, sharp edges, or protrusions which may harm the patient.

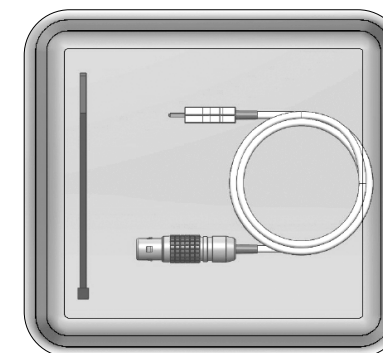

4.2. Inspect EvoEndo Gastroscope Reusable Video Cable (EE-RVC)

- 4.2.1. Check that the pouch is not damaged and the seal is intact. Unpack the device and check that there are no exposed wires or defects. Connect the appropriate end of the Reusable Video Cable to the scope video input on the EvoEndo Controller and connect the Reusable Video Cable to the EvoEndo Controller.

4.3. Inspect and Test the EvoEndo Controller (EE-C)

- 4.3.1. Check that the power supply is present and free from damage.
- 4.3.2. Closely examine the EvoEndo Controller for any damage.
- 4.3.3. Find the Equipotential Terminal on rear side of EE-C. An Equipotential Terminal is provided to optionally connect to a hospital ground/earth system.
- 4.3.4. Locate the nearest wall socket before start of the procedure. Plug in the power supply to the wall socket and to the EE-C.

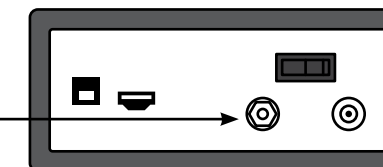

CAUTION: Position the power supply cable where it does not present a trip-hazard. Do not place any objects on the power cord.

CAUTION: If the EvoEndo Controller is used adjacent to or stacked with other equipment, observe and verify normal operation prior to use. Consult Appendix 1 for guidance on placing the EvoEndo Controller.

- 4.3.5. Switch ON by pressing the on/off button. Switch OFF after test.

NOTE: When ON, a green LED will illuminate on the EE-C.

NOTE: Color bars will appear if the Controller is plugged into a medical monitor and a compatible endoscope is not plugged in.

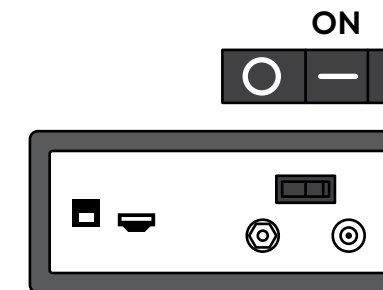

4.4. Test Live Video Image

CAUTION: Ensure the EE-C is powered OFF during all cable connection.

- 4.4.1. With the Controller powered off, connect it to the EvoEndo Gastroscope Reusable Video Cable (PN 1009). Plug the rectangular-shaped plug of the cable into the scope video input on the front of the controller. Then plug the other round end of the video cable into the appropriate connector on the gastroscope by lining up the red dots on the connector and the cable.

- 4.4.2. Connect the Controller to an HD-rated medical-grade monitor with included Ferric HDMI cable (Part 1004).

NOTE: The Controller should only be used with the Ferric HDMI cable provided.

- 4.4.3. Power ON the monitor and the Controller.

- 4.4.4. Point the distal end of EvoEndo Endoscope towards an object, e.g., the palm of your hand.

- 4.4.5. Verify that a live video image appears on the screen.

NOTE: If the object cannot be seen clearly, wipe the lens at the distal end using a clean cloth.

NOTE: A medical-grade anti-fog liquid may also be used on the distal end.

NOTE: If a compatible endoscope is not plugged in or the electronic connection between the scope and the Controller is not secure, color bars will appear on the monitor.

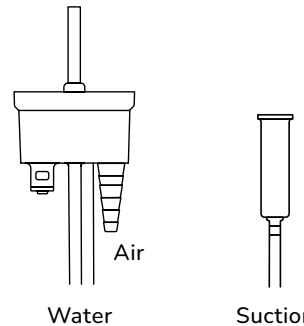
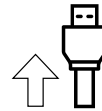
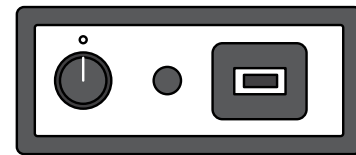

4.5. Connect and Test EvoEndo Endoscope Supply Lines

- 4.5.1. Identify the water supply line on the EvoEndo Endoscope and connect via standard screw-top fitting to a standard 250 ml (minimum) single-use sterile water or saline bottle with 1.25" screw top. Bottle must remain upright and should be secured throughout the procedure.

- 4.5.2. Identify the air supply line on the EvoEndo Endoscope and connect using a push-fit to a pressurized air system (or carbon dioxide) able to supply up to 3 liter per minute flow (provider preference) at 50 psi standard wall pressure or up to 8 psi pressure controlled system (provider preference).

- 4.5.3. Identify the suction line and connect using a push-fit. Ensure a suction vacuum of 200 mmHg or less.

- 4.5.4. Press and hold the water button to check for continuous flow and expected rate.

- 4.5.5. Place the distal tip in the water previously dispensed into the packaging tray, then press and hold the air button to check flow.

- 4.5.6. Place the distal tip back into the dispensed water and press the suction button to check suction function.

- 4.5.7. Verify that any endoscopic accessories to be used can pass through the working channel without excessive resistance.

CAUTION: Ensure any endoscopic accessory used is less than 2 mm outer-diameter and at least 1.1 m for the 85 cm Scope and 1.3 m for the 110 cm Scope.

NOTE: Add several drops of silicone oil or some water-based lubricating jelly to the channel or forceps if resistance is felt.

WARNING: Active endoscopic accessories such as laser probes and electrosurgical equipment are not compatible with the EvoEndo Endoscope and should not be used under any circumstances.

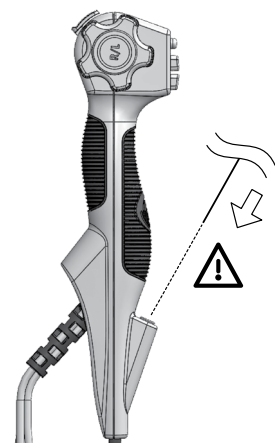
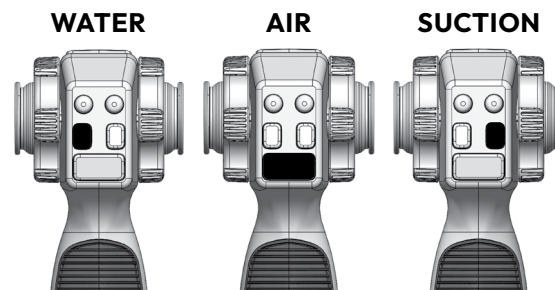

5. EvoEndo Endoscope Operation

WARNING: Excessive force should never be used when operating the EvoEndo Endoscope.

WARNING: If any malfunction should occur during the endoscopic procedure, stop the procedure immediately, put the distal tip in its neutral non-angled position, and slowly withdraw the EvoEndo Endoscope without touching the bending lever.

WARNING: Always observe the live endoscopic image while withdrawing the EvoEndo Endoscope.

WARNING: The temperature of the distal end of the endoscope may exceed 41°C (106°F) and reach up to 43°C (110°F) due to heating of the LEDs. Long, sustained contact with the mucosal membrane may cause mucosal injury. Avoid long periods of contact between the tip of the device and the mucosal membrane. Always maintain a suitable distance necessary for adequate viewing while using the minimum level of illumination for the minimum amount of time.

5.1. Holding the EvoEndo Endoscope

The handle of the EvoEndo Endoscope can be held in either hand.

Use the thumb to move the up/down control lever and the index finger to operate the air/water/suction electronic buttons.

The index finger can also be used to apply left right motion of the distal tip via rotation of the dials while the thumb moves the device tip up/down.

The hand that is not holding the handle can be used to advance the Scope Insertion Tube into the patient's mouth or nose using the preferred hand position of the endoscope operator.

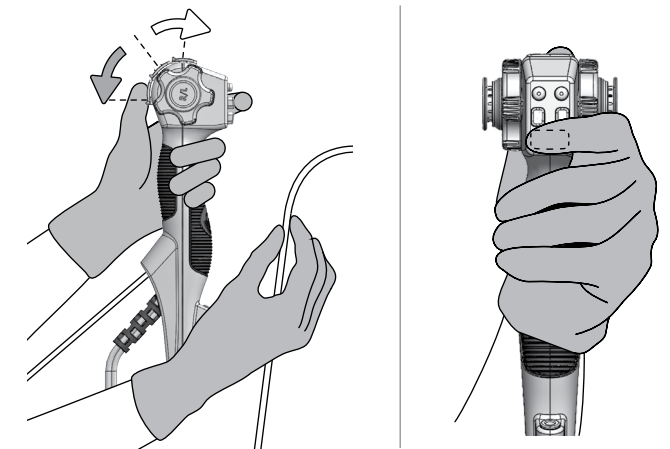

5.2. Manipulating the Tip of the EvoEndo Endoscope

The thumb control lever is used to flex and extend the tip of the EvoEndo Endoscope in the vertical plane.

Moving the control lever downward will make the tip bend anteriorly (flexion).

Moving it upward will make the tip bend posteriorly (extension).

The index control dials (mirror images of each other) are used to flex and extend the tip of the EvoEndo Endoscope in the horizontal plane.

Moving the control dials in either direction will make the tip bend laterally.

CAUTION: The endoscope catheter should be held as straight (planar) as possible at all times in order to maintain optimal tip control.

CAUTION: The device will tolerate twisting, but excessive twisting could break the catheter steering mechanism or decrease the efficacy of steering.

CAUTION: Do not exert excessive force on the gastroscopie tip as this may result in damage to the equipment. Examples of inappropriate handling of the gastroscopie tip include:

- Excessive manual twisting along the insertion tube.
- Operating it inside an endotracheal tube.
- Operation where significant resistance is felt.

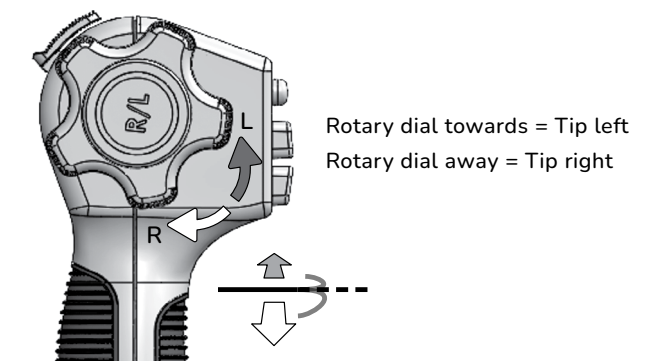
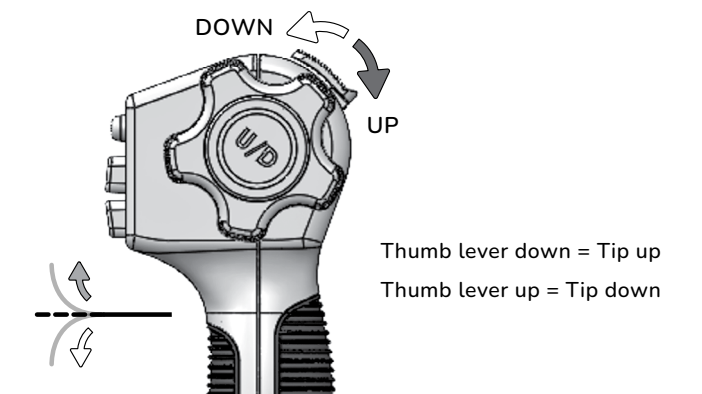

5.2.1. Steering Support System

Note: The Steering Support System will be in the off position when the endoscope is removed from the packaging.
 Note: A provider should activate or deactivate the Steering Support System per their preference before or during the case.

When holding the Scope with the buttons facing forward and away from the user, there are two buttons: one button over the control dial on the right and one button over the control dial on the left.

1. On the right side of the Scope is a button labeled R/L that, when depressed, will increase the resistance of the endoscope steering dials that control right/left endoscope tip deflection and support endoscope deflection. When pulled out, it will decrease resistance and turn off the Steering Support System.
2. On the left side of the Scope is a button labeled U/D that when the button is depressed, will increase the resistance of the endoscope steering lever that controls up/down endoscope tip deflection and support endoscope deflection. When pulled out, it will decrease resistance and turn off the Steering Support System.

5.3. Insertion of the EvoEndo Endoscope

CAUTION: Lubricate the insertion tube with a medical-grade lubricant to ensure the lowest friction when the EvoEndo Endoscope is inserted into the patient.

CAUTION: When inserting the EvoEndo Endoscope orally, it is recommended to use a mouthpiece to protect the Scope from damage.

NOTE: If the camera image of the EvoEndo Endoscope becomes unclear, the tip can be cleaned by gently rubbing the tip against the mucosal wall using suction to evacuate and clear material from the endoscope lens or by fully withdrawing the Scope and cleaning the tip with an anti-fog liquid, clean gauze, or a microfiber cloth.

5.4. Instillation of Fluid

With a standard 250 ml (minimum) 1.25" screw-top single-use water container connected, press and hold the water button to add water to the investigation site. It may take a few seconds for water to exit the endoscope channel after depressing the water button.

WATER

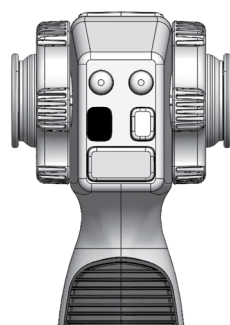

- 5.4.1. In addition to the integrated water supply function, fluids may also be instilled directly down the working channel by inserting a 1" blunt tip needle attached to a luer lock syringe into the working channel at the top of the EvoEndo Endoscope.

Insert the syringe completely into the working channel port or the introducer. Failure to do so may result in the fluid spilling from the working channel port.

- 5.4.2. Press the plunger to instill fluid.

CAUTION: Make sure you do not apply suction during this process, as this will direct the instilled fluids into the suction collection system.

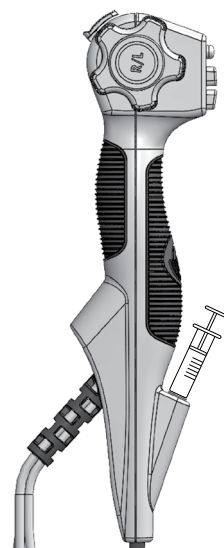

5.5. Aspiration

Suction can be applied by pressing the suction button with the index finger.

WARNING: Ensure that the suction connector on the EvoEndo Single-Use Endoscopy System is only connected to a medical-grade suction apparatus.

WARNING: Use a suction vacuum of 200 mmHg or less. Too high a vacuum may lead to difficulty terminating suction.

SUCTION

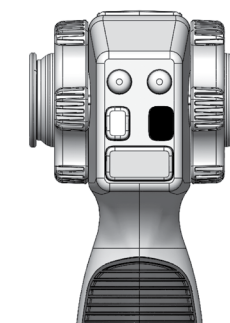

5.6. Insufflation

To achieve air insufflation, press and hold the air button for continuous flow.

WARNING: Ensure the use of short bursts of insufflation to reduce the risk of over insufflation and the associated risks of gas embolism.

AIR

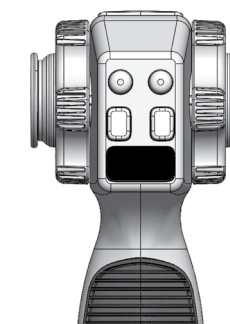

5.7. Imaging Buttons

- 5.7.1. Freeze Image

To freeze the image, use a single short press (1 second) of the button directly above the water button.

- 5.7.2. White Balance Reset

White balance is factory-optimized for each device. However, if this setting is adjusted or problematic, then press and hold (2 seconds) the button directly above the water button to reset the white balance.

FREEZE IMAGE
1 SEC

WHITE BALANCE
2 SEC

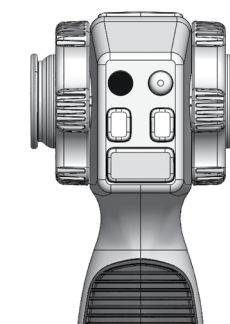

- 5.7.3. User-Assigned Function Button

Users can program button (with support of EvoEndo Technician) to be compatible with a third-party image capture system. A press can then trigger an image capture of the viewed endoscope image if so desired.

- 5.7.4. Enhance Image

To adjust luminance levels and bring out details in the dark regions of the image, use a single long press (2 seconds) of the button directly above the suction button. Pressing this button will toggle between two different luminance levels.

USER-ASSIGNED
FUNCTION
1 SEC

ENHANCE IMAGE
2 SEC

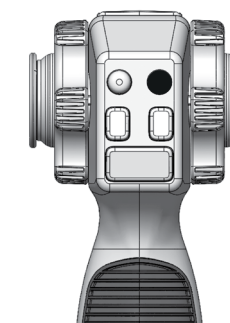

5.8. Insertion of Endoscopic Accessories

WARNING: Do not use active endoscopic accessories such as laser probes or electrosurgical equipment in conjunction with the EvoEndo Single-Use Endoscopy System, as this may result in patient injury or damage to EvoEndo Endoscope.

WARNING: To maintain patient safety and the safety of the end user, use only medical approved accessories.

WARNING: Do not advance or withdraw EvoEndo Endoscope or operate the bending section while endoscopic accessories are protruding from the distal end of the working channel, as this may result in injury to the patient.

CAUTION: Never use excessive force when advancing or withdrawing an endoscopic accessory inside the working channel. Failure to observe the above may result in damage to the working channel.

CAUTION: Ensure any endoscopic accessory used is less than 2 mm outer diameter and at least 1.3m working length for 110 cm gastroscope model or 1.1 m for 85 cm gastroscope model (see Section 4.4.7).

CAUTION: Inspect the endoscopic accessory before using it. If there is any irregularity in its operation or external appearance, replace it.

CAUTION: Insert the endoscopic accessory into the working channel port and advance it carefully through the working channel until it can be seen on the external monitor.

CAUTION: Extra care should be taken when steering the EvoEndo Endoscope if accessories are protruding from the distal tip.

NOTE: There is no guarantee that instruments selected solely using this minimum instrument channel width will be compatible in combination.

5.9. Withdrawal of the EvoEndo Endoscope

5.9.1. Prior to removal, check the tip position and remove any endoscopic accessories to ensure safest possible removal.

5.9.2. Slowly withdraw the EvoEndo Endoscope while watching the live image to check for safe extraction.

WARNING: While withdrawing the EvoEndo Endoscope, do not operate the Thumb Lever or Dials to allow the distal tip to exit in a neutral position.

WARNING: Before withdrawing the EvoEndo Endoscope, be sure that the Steering Support System is in the off position.

NOTE: If the EvoEndo Endoscope is used more than once on the same patient during the same procedure, place it on a clean surface in between sessions.

NOTE: It is recommended to have the Steering Support System in the off position (button non-depressed) when withdrawing the endoscope.

5.10. After Use

5.10.1. Switch off the Controller.

5.10.2. Remove the Reusable Video Cable from the connections at the EvoEndo Endoscope and Controller.

5.10.3. Disconnect all supply lines from the EvoEndo Endoscope.

5.10.4. Dispose of the EvoEndo Endoscope in accordance with local guidelines for collection of infected medical devices with electronic components.

5.10.5. Dispose of any other single-use components (e.g., water bottle, suction canister, etc.) in accordance with hospital guidelines.

5.10.6. Clean the Controller and Reusable Video Cable as described in Section 7.

WARNING: The EvoEndo Endoscope is a single-use device and must not be reprocessed under any circumstances.

WARNING: The EvoEndo Endoscope is considered contaminated after use and must be disposed of in accordance with local guidelines for collection of infected medical devices with electronic components.

5.10.7. Keep Reusable Video Cable secured to the Controller. The Video Cable can be used for up to ten (10) procedures. Discard the Video Cable after 10 uses.

6. EvoEndo Controller (EE-C) Operation

WARNING: Explosion Hazard – Use with caution in the presence of flammable anesthetics. Do not store liquids on or above this unit. Type BF Class II Equipment when used with the EvoEndo Endoscope.

6.1. EvoEndo Controller Output Modes

6.1.1. Basic – direct access (HDMI)

Live image available while connected to a medical-grade HDMI compatible monitor.

NOTE: For optimal performance, use a medical-grade monitor that is 27" minimum, HD 1080p or higher resolution, and 1000 nits brightness.

6.2. EvoEndo Controller Setup

6.2.1. Connect EvoEndo power supply (supplied) and Ferric HDMI cable (supplied) on the rear of the Controller.

NOTE: The Controller should only be used with the Ferric HDMI cable provided.

6.2.2. Connect the EvoEndo Endoscope to the Reusable Gastroscope Video Cable that is connected to the EvoEndo Controller.

6.2.3. Press the power switch on the rear of the Controller to ON position.

6.2.4. Conduct procedure, adjusting the image brightness sensitivity as required using the rotary dial on the front of the Controller.

NOTE: The Controller and live image may be left connected and powered on during Scope extraction as part of multiple investigations of the same patient within the same session.

6.2.5. With EvoEndo Endoscope removed from patient, press button to OFF position.

6.2.6. Disconnect the EvoEndo Endoscope and process as waste.

6.2.7. Disconnect the Reusable Video Cable from the EvoEndo Endoscope. Leave the Reusable Video Cable attached and secured to the Controller.

6.2.8. Clean the EvoEndo Controller and EvoEndo Gastroscope Reusable Video Cable as described in Section 7.

WARNING: Do not attempt to open or service the EvoEndo Controller; refer to Warranty and Replacement Program in Appendix 4 and contact EvoEndo for a replacement. No routine service or maintenance is required.

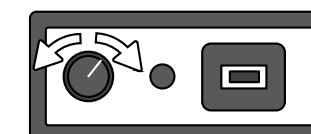
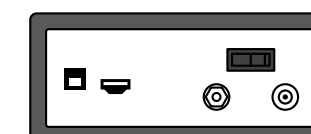
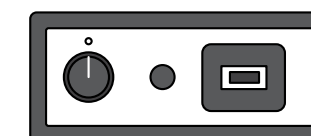

7. Cleaning the EvoEndo Controller and EvoEndo Gastroscope Reusable Video Cable

The EvoEndo Controller and EvoEndo Gastroscope Reusable Video Cable must be cleaned per hospital policy before and after each use. Ensure the Controller is cleaned thoroughly prior to first use.

7.1. Cleaning of the EvoEndo Controller

- 7.1.1. Ensure the Controller is disconnected.
- 7.1.2. Use a standard cleaning detergent to clean the EvoEndo Controller according to hospital policy.
- 7.1.3. After cleaning, the EvoEndo Controller must be submitted to the pre-check procedure described in section 4.2.

WARNING: Avoid getting the device wet to prevent damaging internal electronic components.

WARNING: Do not attempt to clean and reuse the EvoEndo Endoscope as it is a single-use device.

WARNING: Clean the medical-grade monitor after each use according to the relevant manufacturer guidelines.

WARNING: Disconnect EvoEndo Controller from any mains power supply, remove any accessories, and make sure the Controller is turned off before cleaning.

WARNING: Do not spray liquid directly on the Controller.

NOTE: Between procedures, the EvoEndo Controller must be stored in accordance with local guidelines.

7.2. Cleaning of the EvoEndo Gastroscope Reusable Video Cable

- 7.2.1. Using Super Sani-Cloth® Germicidal Wipe, thoroughly wipe all accessible exterior surfaces of the EvoEndo Gastroscope Reusable Video Cable.
- 7.2.2. Allow the surfaces of the Video Cable to remain wet for at least 2 minutes. Additional wipes may be used to ensure the surface remains wet for the duration of the time.
- 7.2.3. After the 2 minutes, use a clean, dry, lint-free cloth to wipe the exterior surfaces of the Video Cable dry. Inspect the Video Cable for any remaining visible soil. If soil is noted, repeat the above steps.

8. Troubleshooting

If problems occur with the EvoEndo Endoscopy System, please use this trouble-shooting guide to identify the cause and correct the error. If troubleshooting is not effective, please contact an EvoEndo technician.

8.1. No live image

CAUSE	ACTION
EvoEndo Endoscope not securely connected to EvoEndo Controller	Check connections of EvoEndo Endoscope and EvoEndo Gastroscope Reusable Video Cable with the Controller
EvoEndo Controller and EvoEndo Endoscope have communication problems	Check rear connections from EvoEndo Controller to video output (HDMI)
EvoEndo Endoscope or EvoEndo Controller is damaged	Replace EvoEndo Endoscope or EvoEndo Controller

8.2. Low picture quality

CAUSE	ACTION
Dirt or debris on the distal tip of the EvoEndo Endoscope	Clean end of EvoEndo Endoscope with microfiber sterile cloth, gauze, or cotton swab
Hardware poor connection	Turn EvoEndo Controller off and on, check connections, troubleshoot per third-party system instructions
Scratched optical mechanism on EvoEndo Endoscope	Replace EvoEndo Endoscope

8.3. Absent or reduced suction capability

CAUSE	ACTION
Channel blocked	Flush channel with 10 ml of sterile water, clean channel with endoscopic brush of appropriate size, or replace EvoEndo Endoscope
Suction source is malfunctioning	Replace or try new suction source or supply tubing

8.4. Difficult to insert endoscopic accessory through the channel

CAUSE	ACTION
Channel blocked	Clean EvoEndo Endoscope channel with 10 ml of sterile water or endoscopic brush of appropriate size, or replace EvoEndo Endoscope
Accessory is too big	Use proper size accessory for 2 mm channel
Backflow valve is not functioning	Attempt puncture of valve with sterile blunt device or replace EvoEndo Endoscope
Distal tip not in neutral position	Adjust mechanisms to achieve neutral position

9. Technical Product Specifications

9.1. EvoEndo Model LE Single-Use Gastroscope Specifications

OPTICAL SYSTEM

Field of view	120° diagonal, 87.5° horizontal
Depth of field	>2.5 mm
Illumination method	LED

INSERTION PORTION

Endoscope tip	210° up, 90° down, 180° left, 180° right
Insertion tube diameter	3.5 mm (0.14")
Distal end diameter	3.5 mm (0.14")
Maximum diameter of insertion portion	3.5 mm (0.14")
Working length	Model LE 85 = 85 cm (33.5") Model LE 110 = 110 cm (43.3")

CHANNEL

Average inner diameter	2.0 mm (0.078")
Minimum instrument channel width	2.0 mm (0.078")
Air connector	Connects to 1/4"– 3/8" supply lines
Water connector	Connects to bottle with 1.25" top
Suction connector	Connects to standard 6 mm suction device

OPERATING ENVIRONMENT

Intended for use under standard ambient environmental conditions consistent with those found in ambulatory care environments.

STORAGE

Store the sterile device in a cool, dry place, protected from direct sunlight, moisture, and excessive heat. Ensure the primary packaging remains intact to preserve sterility.

STERILIZATION

Method of sterilization	EtO
-------------------------	-----

9.2. EvoEndo EE-C Specifications

Power requirement 12V 1.0A DC input

OPERATING ENVIRONMENT

Intended for use under standard ambient environmental conditions consistent with those found in ambulatory care environments.

DIMENSIONS

Width	15.0 cm
Height	6.0 cm
Length	21.5 cm
Weight	2 lbs 5 oz (1.1 kg)
Video output connection	HDMI

STORAGE

Store the controller in a cool, dry place, protected from direct sunlight, moisture, and excessive heat.

9.3. EvoEndo EE-C Power Supply Specifications

ELECTRICAL POWER

Power requirement	100–240V AC, 50–60Hz, 0.5A
Power out	12V DC, 1.0A

OPERATING ENVIRONMENT

Intended for use under standard ambient environmental conditions consistent with those found in ambulatory care environments.

STORAGE

Store the power supply in a cool, dry place, protected from direct sunlight, moisture, and excessive heat.

PLUGS

Between the power supply and EvoEndo EE-C	Ø5.5 mm DC jack connector
Between the EvoEndo Reusable Video Cable and EvoEndo EE-C	Edge card connector

9.4. Reusable Video Cable

ELECTRICAL POWER

Power requirement	12V DC, 1.0A (from EE-C)
-------------------	--------------------------

PLUGS

Between the EvoEndo Reusable Video Cable and EvoEndo EE-C	Edge card connector
Between the EvoEndo Reusable Video Cable and Scope	10-pin plug

DIMENSIONS

Length	2.0 m
Diameter	3.0 mm

OPERATING ENVIRONMENT

Intended for use under standard ambient environmental conditions consistent with those found in ambulatory care environments.

STORAGE

Store the Reusable Video Cable in a cool, dry place, protected from direct sunlight, moisture, and excessive heat.

Appendix 1. Electromagnetic Compatibility

Essential Performance Statement

The EvoEndo Single-Use Endoscopy System provides live continuous images in color, at resolution specified by the camera Manufacturer. During imposed interference the image may distort or diminish, i.e., flicker, display as grayscale or less intensity but will recover within 5 seconds after the interference has ceased. Operator may recycle power to restore functionality (in case the video unit is frozen). If up to three power recycles are necessary, operator should cancel procedure and restart once imposed interference ceases. The device use is not life threatening, therefore it is acceptable to recycle power and start over. Visual corroboration of quality is an acceptable method.

Like other electrical medical equipment, the EvoEndo Single-Use Endoscopy System requires special precautions to ensure electromagnetic compatibility (EMC) with other electrical medical devices. To ensure electromagnetic compatibility the EvoEndo Single-Use Endoscopy System must be installed and operated according to the EMC information provided in this manual.

The EvoEndo Single-Use Endoscopy System has been designed and tested to comply with IEC 60601-1, IEC 60601-1-2, IEC 60601-2-18, and IEC 62471 requirements for EMC with other devices.

WARNING: Electronic equipment may affect the normal function of the EvoEndo Single-Use Endoscopy System.

WARNING: The EvoEndo Single-Use Endoscopy System consists of the parts described in section 2. They may only be replaced by authorized parts. Failure to comply with this may reduce safety and efficiency.

WARNING: Use of this equipment adjacent to or stacked with other equipment should be avoided because it could result in improper operation. If such use is necessary, this equipment and the other equipment should be observed to verify that they are operating normally.

Cables Provided with the EvoEndo System

Cable	Maximum Length
Ferric HDMI Cable – Part Number 1004	6 ft
Medical-Grade Power Supply – Part Number 1003	5 ft
EvoEndo Gastroscope Reusable Video Cable – Part Number 1009	6.5 ft

WARNING: Use of accessories, transducers, and cables other than those specified or provided by the manufacturer of this equipment could result in increased electromagnetic emissions or decreased electromagnetic immunity of this equipment and result in improper operation.

Guidance and Manufacturer's Declaration: Electromagnetic Emissions

The EvoEndo Single-Use Endoscopy System is intended for use in the electromagnetic environment specified below. The customer or the user of EvoEndo Single-Use Endoscopy System shall ensure that it is used in such environment.

Emission Test	Compliance	Electromagnetic Environment – Guidance
RF emissions CISPR 11	Group 1	This instrument is an unintentional radiator. Hence RF energy it generates is a byproduct of its internal functions. While the instrument complies with the limit to which it was tested, it may cause interference.
Radiated emissions CISPR 11	Class A	This instrument's RF emissions are very low and not likely to cause any interference in nearby electronic equipment.
Mains terminal conducted emissions CISPR 11		
Harmonic emissions IEC 61000-3-2	Class A	This instrument's harmonic emissions are low and not likely to cause interference in a typical commercial power grid to which this instrument is connected.
Voltage fluctuations / flicker emissions IEC 61000-3-3	Complies	This instrument stabilizes its own radio variability and has no effect, such as flicker in lighting apparatus.

NOTE: The EMISSIONS characteristics of this equipment make it suitable for use in industrial areas and hospitals (CISPR 11 Class A). If it is used in a residential environment (for which CISPR 11 class B is normally required) this equipment might not offer adequate protection to radio-frequency communication services. The user might need to take mitigation measures, such as relocating or reorienting the equipment.

Guidance and Manufacturer's Declaration: Electromagnetic Immunity

The EvoEndo Single-Use Endoscopy System is intended for use in the electromagnetic environment specified below. The customer or the user of the EvoEndo Single-Use Endoscopy System shall ensure that it is used in such an environment.

Immunity Test	IEC 60601 Test Level	Compliance Level	Electromagnetic Environment – Guidance
Electrostatic Discharges IEC 61000-4-2	Contact: ± 8 kV Air: ± 15 kV	Same as test level	Floors should be made of wood, concrete, or ceramic tile that hardly produces static. If floors are covered with synthetic material that tends to produce static, the relative humidity should be at least 30%.
Electrical Fast Transients and Bursts IEC 61000-4-4	± 2 kV for power supply lines	Same as test level	Mains power quality should be that of a typical commercial (original condition feeding the facilities) or hospital environment.
Surges IEC 61000-4-5	Differential mode: ± 0.5, ± 1 kV Common mode: ± 0.5, ± 1, ± 2 kV	Same as test level	Mains power quality should be that of a typical commercial or hospital environment.
Voltage Dips and Interruptions IEC 61000-4-11	> 95% for 0.5 cycles > 95% for 1 cycle 30% for 25/30 (50 Hz) cycles > 95% for 250 (50 Hz) cycles	Same as test level	Mains power quality should be that of a typical commercial or hospital environment. If the user of this instrument requires continued operation during power mains interruptions, it is recommended that this instrument be powered from an uninterruptible power supply or a battery.
Rated Power Frequency Magnetic Field IEC 61000-4-8	30 A/m	Same as test level	It is recommended to use this instrument by maintaining enough distance from any equipment that operates with high current.

Guidance and Manufacturer's Declaration: Electromagnetic Immunity

The EvoEndo Single-Use Endoscopy System is intended for use in the electromagnetic environment specified below. The customer or the user of EvoEndo Single-Use Endoscopy System shall ensure that it is used in such environment.

WARNING: Portable RF communications equipment (including peripherals such as antenna cables and external antennas) should be used no closer than 30 cm (12 inches) to any part of the EvoEndo Single-Use Endoscopy System, including cables specified by the manufacturer. Otherwise, degradation of the performance of this equipment could result.

Immunity Test	IEC 60601 Test Level	Compliance	Electromagnetic Environment – Guidance
Conducted Disturbances, induced by RF fields IEC 61000-4-6	3 V rms outside the ISM band, 6 V rms in the ISM band (150KHz – 80MHz)	3 V (V1)	Recommended separation distance $d = \left[\frac{3.5}{V_1} \right] \sqrt{P}$
Radiated RF IEC 61000-4-3	3 V/m (80 MHz – 2.7 GHz)	3 V/m (E1)	$d = \left[\frac{3.5}{E_1} \right] \sqrt{P}$

Definition: Where “P” is the maximum output power rating of the transmitter in watts (W) according to the transmitter manufacturer and “d” is the recommended separation distance in meters (m).

NOTES

- At 80 MHz and 800 MHz, the higher frequency range applies.
- These guidelines may not apply in all situations. Electromagnetic propagation is affected by absorption and reflection from structures, objects, and people.
- Interference may occur in the vicinity of equipment marked with the following symbol: 
- Field strengths from fixed RF transmitters, as determined by an electromagnetic site survey, should be less than the compliance level in each frequency range.
 - ^a Field strengths from fixed transmitters, such as base stations for radio (cellular/cordless) telephones and land mobile radios, amateur radio, AM and FM radio broadcast, and TV broadcast, cannot be predicted theoretically with accuracy. To assess the electromagnetic environment due to fixed RF transmitters, an electromagnetic site survey should be considered. If the measured field strength in the location in which this instrument is used exceeds the applicable RF compliance level above, this instrument should be observed to verify normal operation. If abnormal performance is observed, additional measures may be necessary, such as re-orienting or relocating this instrument.
 - ^b Over the frequency range 150 kHz to 80 MHz, field strengths should be less than 3 V/m.

Recommended Separation Distances Between Portable and Mobile RF Communications Equipment and the EvoEndo Single-Use Endoscopy System

The EvoEndo Single-Use Endoscopy System is intended for use in an electromagnetic environment in which radiated RF disturbances are controlled. The customer or the user of the EvoEndo Single-Use Endoscopy System can help prevent electromagnetic interference by maintaining a minimum distance between portable and mobile RF communications equipment (transmitters) and the EvoEndo Single-Use Endoscopy System as recommended below, according to the maximum output power of the communications equipment.

Rated maximum output power of transmitter P (W)	Separation distance according to frequency of transmitter (m) (calculated as $V1=3$ and $E1=3$)	
	150 kHz – 80 MHz $d = 3.5\sqrt{P}$	80 MHz – 2.7 GHz $d = 3.5\sqrt{P}$
0.01	0.35	0.35
0.1	1.1	1.1
1	3.5	3.5
10	11	11
100	35	35

NOTES:

- For transmitters rated at a maximum output power not listed above, the recommended separation distance 'd' in meters (m) can be estimated using the equation applicable to the frequency of the transmitter, where 'p' is the maximum output power rating of the transmitter in watts (W) according to the transmitter manufacturer.
- At 80 MHz and 800 MHz, the separation distance for the higher frequency range applies.
- These guidelines may not apply in all situations. Electromagnetic propagation is affected by absorption and reflection from structures, objects, and people.

Appendix 2. Standards Applied

The EvoEndo Model LE Single-Use Gastroscopy function conforms with:

- IEC 60601-1: Medical electrical equipment – Part 1: General requirements for safety.
- IEC 60601-2-18: Medical electrical equipment – Part 2-18: Particular requirements for the safety of endoscopic equipment.
- ISO 8600-1: Optics and photonics – Medical endoscopes and endotherapy devices – Part 1: General requirements.
- IEC 60601-1-2: Medical electrical equipment – Part 1-2 General requirements for safety – Collateral standard: Electromagnetic compatibility – Requirements for test.
- IEC 62471: Photobiological safety of lamps and lamp systems.

The EvoEndo EE-C function conforms with:

- IEC 60601-1: Medical electrical equipment – Part 1: General requirements for safety.
- EN 60601-1-1: Medical electrical equipment – Part 1: General requirements for safety– Collateral standard: Electromagnetic compatibility – Requirements for test.

The EvoEndo EE-C power supply conforms with:

- IEC 60601-1: Medical electrical equipment – Part 1: General requirements for safety.
- EN 60601-1-1: Medical electrical equipment – Part 1: General requirements for safety – Collateral standard: Electromagnetic compatibility – Requirements for test.

The EvoEndo Reusable Video Cable conforms with:

- IEC 60601-1 Medical electrical equipment – Part 1: General requirements for safety.
- EN 60601-1-1 Medical electrical equipment – Part 1: General requirements for safety – Collateral standard: Electromagnetic compatibility – Requirements for test.

Appendix 3. Security

Access and Configuration

The EvoEndo Single-Use Endoscopy System is a standalone device that does not connect to networks or other devices. It is not capable of accessing any network or the internet, either wired or wireless.

Electronic Interfaces

The EvoEndo Single-Use Endoscopy System has 1 HDMI port on the rear panel that is intended for the user. The EvoEndo Single-Use Endoscopy System has 1 USB 3.0 service port on the rear panel that is intended for use by EvoEndo Inc. manufacturing service personnel only. The USB service port on the rear panel is disabled and ignores inputs when powered on in the healthcare facility use environment. The USB service port is only meant for service use by EvoEndo Inc.

Maintenance of Cybersecurity Level

The EvoEndo Single-Use Endoscopy System Instructions for Use identifies troubleshooting steps to take if issues occur with the device functions. Please contact the EvoEndo Inc. customer service department if the troubleshooting steps do not resolve the issue. It is recommended to have a readily available substitute device to ensure continuous operation in case of device malfunction.

The EvoEndo Single-Use Endoscopy System is designed with a method for retention and recovery of trusted default device configuration by authenticated, authorized EvoEndo Inc. manufacturing personnel. The user does not have access to the device configuration. Please contact the EvoEndo Inc. customer service department if any problems with the device occur.

EvoEndo Inc. will provide all necessary services, including software updates, to maintain functionality, performance, cybersecurity level, and conformity of the device throughout the life and service of the EvoEndo Inc. This includes the assessment of potential security risks and, if required, delivery of information and software updates. Where relevant, EvoEndo Inc. will inform users of the vulnerability details and appropriate countermeasures, as applicable, through the EvoEndo Inc. customer service department. Software updates will be conducted by authorized EvoEndo Inc. manufacturing personnel to maintain the cybersecurity level and resolve any unacceptable vulnerabilities.

Appendix 4. Warranty and Replacement Program

The warranty period for the EvoEndo Controller is three years from delivery to the customer. We agree to replace an EvoEndo EE-C free of charge if proof can be provided of faulty materials or faulty workmanship. In doing so, we cannot accept the cost of transportation or risk of shipment. There is no warranty on the EvoEndo Model LE Single-Use Gastroscopy.

Ensure any part of the system being returned is thoroughly disinfected before shipping to EvoEndo. EvoEndo reserves the right to return contaminated medical devices to the sender.

Procedure Summary

Unpack and Inspect

- ❑ Device packaging not damaged?
- ❑ Device free from defects and not damaged during unpacking?
- ❑ Controller and Reusable Video Cable cleaned from previous use?

Connect and Test

- ❑ Can make appropriate electrical connections?
- ❑ Image quality sufficient?
- ❑ Can make appropriate tube/supply connections?
- ❑ Successfully ID buttons air/water/suction?
- ❑ Air/water/suction functioning correctly?
- ❑ Successfully ID buttons freeze image, white-balance, and enhance image?
- ❑ Visually checked vertical tip control (thumb lever)?
- ❑ Visually checked horizontal tip control (rotary dial)?
- ❑ Endoscopic accessories fit the working channel?

Perform Endoscopic Procedure

Withdraw, Dispose and Clean

- ❑ Remove any endoscopic accessories
- ❑ Discard Scope
- ❑ Recycle plastic and cardboard packaging
- ❑ Clean Controller and Reusable Video Cable

Controls Identification

