

# RT21M6215SR

SAMSUNG

## Samsung Top-Freezer Refrigerator

21 cu. ft. Capacity



### Signature Features

#### FlexZone™

- Versatile fridge compartment that converts freezer to fridge.

#### Twin Cooling Plus®

- Maintains both high levels of refrigerator humidity to keep perishable fruits and vegetables fresher longer, and dry freezer conditions means less freezer burn for better-tasting frozen foods.

#### Slide & Reach Pantry

- Easily access all your favorite foods.

### Available Color



Fingerprint Resistant  
Stainless Steel



FlexZone™



Slide & Reach Pantry

### Features

- Large Capacity – 21 cu. ft.
- ENERGY STAR® Most Efficient
- Twin Cooling Plus® (FlexZone™)
- True No-Frost Technology
- Auto Ice Maker
- LED Top Lighting
- Fresh Room
- Vegetable Bins
- Dairy Bin
- Garage Ready

### Convenience

- Reversible Door
- Recessed Door Handle
- Sabbath Mode

### Rating



478 kWh/yr

# RT21M6215SR

# SAMSUNG

## Samsung Top-Freezer Refrigerator

21 cu. ft. Capacity

### Installation Specifications

1. Measure the height, width and depth of the opening, making sure to include baseboards, molding tile, countertop overhang, etc. Check to be sure there is enough room to open the door (consider walls, islands or other obstacles when measuring).
2. Refer to illustration below to determine dimensions.
3. Allow 2.5" of clearance on hinge side of refrigerator when installing next to a wall where handle may make contact.
4. Allow 2" minimum clearance at rear for proper air circulation and water/electrical connections. Allow a 3/8" minimum clearance at sides and top for ease of installation.
5. Ensure each door and entryway in the home is wide enough for the refrigerator to be moved through easily.

For optimal usage and to be able to open refrigerator doors completely, do not install next to a wall.

Please note: The following dimension and cutout information is for planning purposes only. For complete installation details, consult manual packed with product, or download manual online at [samsung.com](http://samsung.com).

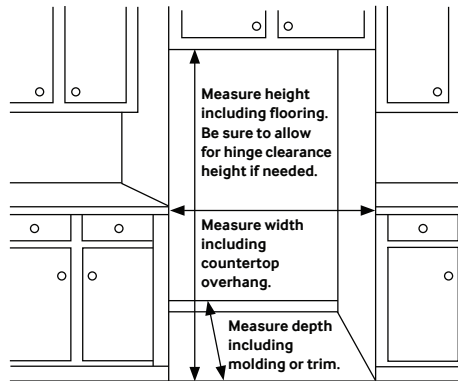

### Dimensions

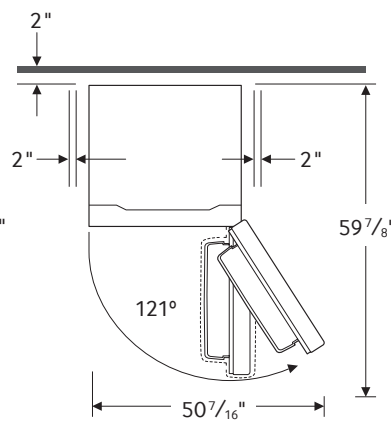
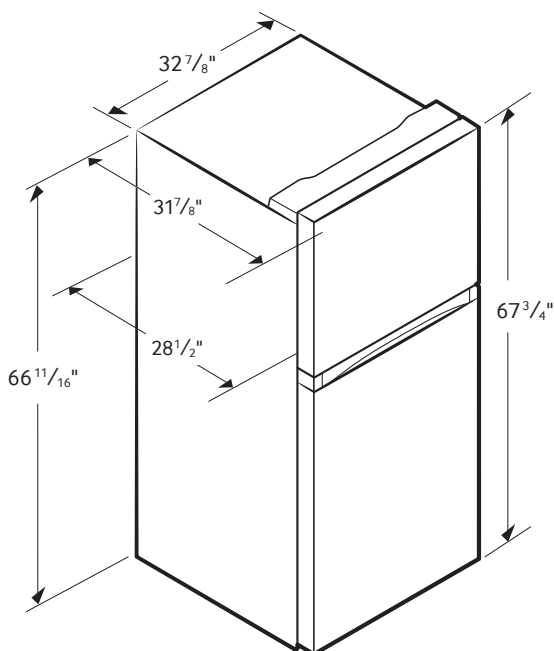

NOTE: Please allow 3 3/4" of clearance when installing along a wall.

**Total Capacity: 21.1 cu. ft.**

**Refrigerator: 15.4 cu. ft.**

- Fresh Room
- Dairy Bin
- 2 Vegetable Bins
- LED Top Lighting

**Fridge in Freezer: 5.7 cu. ft.**

- 1 Glass Shelf

### Warranty

One (1) Year Parts and Labor on Refrigerator

Five (5) Years Parts and Labor on

Sealed Refrigeration System Only\*

Ten (10) Years Parts and Five (5) Years

Labor on Digital Inverter Compressor

\*Compressor, evaporator, condenser, drier and connecting tubing.

### Product Dimensions & Weight

Dimensions (WxHxD with hinges, handles and doors):

32<sup>7</sup>/<sub>8</sub>" x 67<sup>3</sup>/<sub>4</sub>" x 31<sup>7</sup>/<sub>8</sub>"

Dimensions (WxHxD without hinges and door):

32<sup>7</sup>/<sub>8</sub>" x 66<sup>11</sup>/<sub>16</sub>" x 28<sup>1</sup>/<sub>2</sub>"

Weight: 200.6 lbs.

### Shipping Dimensions & Weight (WxHxD)

Dimensions: 34<sup>3</sup>/<sub>8</sub>" x 71<sup>5</sup>/<sub>8</sub>" x 33<sup>1</sup>/<sub>2</sub>"

Weight: 218.2 lbs.

### Color

Fingerprint Resistant

Stainless Steel

### Model #

RT21M6215SR

### UPC Code

887276191874