

# Why ?

## A Truly Unique Player on the Wireless )) Sensor Market

When evaluating different wireless sensors there are many parameters to consider. It may seem overwhelming at first, but each technology has its strong and weak points. Understanding these will help you make the right decision for your business.

The first and main two parameters to consider are range and battery life.

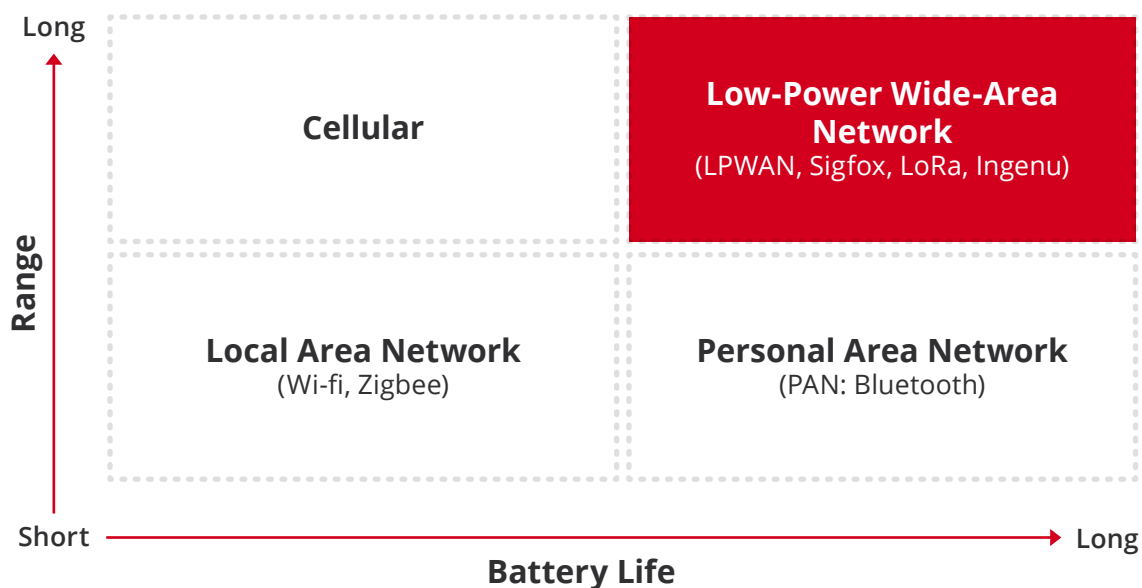

As you can see from the figure above, cellular devices are great for long distance. However, they cannot really operate for a longer time on a single battery charge. And this makes sense, as this technology was designed for larger data throughput. Sensor data readings do not require large data, as it typically is just a few numerical values.

Similarly, one can make the case against using Wi-Fi for wireless sensors – the technology was designed for larger data necessities, with most devices being either plugged in or charged regularly. Bluetooth can potentially work for longer periods of time without charging. For price-sensitive applications, where the distances are small (a couple of meters) Bluetooth may work. But wherever you need a reliable wireless sensor connection that extends beyond 20 meters and can work autonomously for several years, the low-power wide-area network technologies are the best solution, both in terms of range and battery life. While you wouldn't be able to download a movie via LPWAN, when it comes to applications such as measurements or telemetry that require relatively small data throughput, there is no better solution than this.

But wherever you need a reliable wireless sensor connection that extends beyond 20 meters and can work autonomously for several years, the low-power wide-area network technologies are the best solution, both in terms of range and battery life. While you wouldn't be able to download a movie via LPWAN, when it comes to applications such as measurements or telemetry that require relatively small data throughput, there is no better solution than this.

## LPWAN

Low-power wide-area network or LPWAN is a specifically designed wireless communication network that allows long-range communications at a low bit rate between battery-operated sensors and gateways. There are several competing technology platforms within this domain, the two most popular being LoRa and SigFox. Each of them have slightly different features and applications. SigFox works only with network operators and keeps ownership of most of its devices, except the endpoints. SigFox aims to become the world's largest IoT network by working with a single operator in each country, effectively going for public networks only. LoRa, on the other hand, has both – options of the public networks via operators and deployment of private networks which is often necessary for IoT projects.

## LoRa and LoRaWAN

LoRa stands for Long Range and it defines the technology on a physical layer – the principle of radio frequency modulation. LoRaWAN is the most popular protocol for managing communication between LPWAN gateways and sensors maintained by the LoRa Alliance. The main idea of the LoRaWAN protocol is that the network nodes and gateways can be assembled between different manufacturers that are able to work together. LoRaWAN manages the communication frequencies, data rate and power for all of the devices.

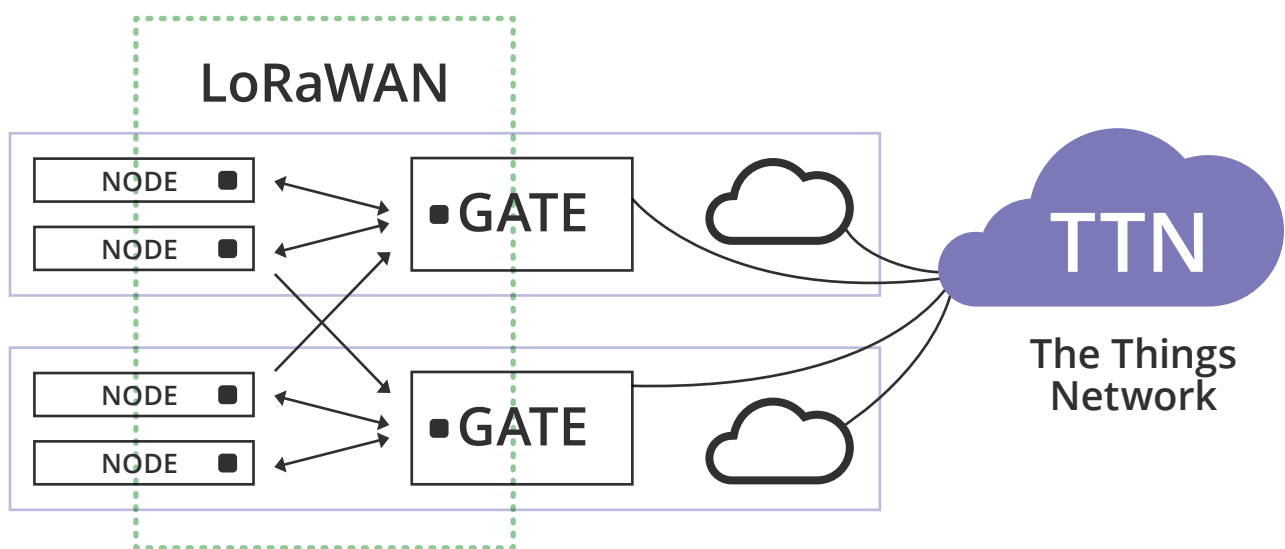

## Aranet

Aranet Radio works in sub-gigahertz ISM 868/920 MHz frequency band and uses LoRa modulation technology, but not the LoRaWAN protocol. Aranet Radio has its own proprietary protocol. This offers several benefits to the user which we will describe below. The communication protocol between the Aranet base station and Aranet sensors is proprietary. It is custom-developed by the industry-leading wireless radio manufacturer **SAF Tehnika**, and is not compatible with LoRaWAN devices.

You can, however, use 3rd party sensors with Aranet 4-20 mA, Voltage and Pulse wireless transmitters and integrate your Aranet PRO base station via MQTT or the Aranet Cloud via SenML. Therefore the system is open for integration on both the sensor and the base station sides and Aranet takes care of the radio communication between them. With Aranet you control the whole IoT environment – from sensors to the base station to the Cloud.

In addition, Aranet base stations offer far greater range of capabilities than typical LoRa gateways. Aranet base station incorporates gateway, database and webserver functionalities.

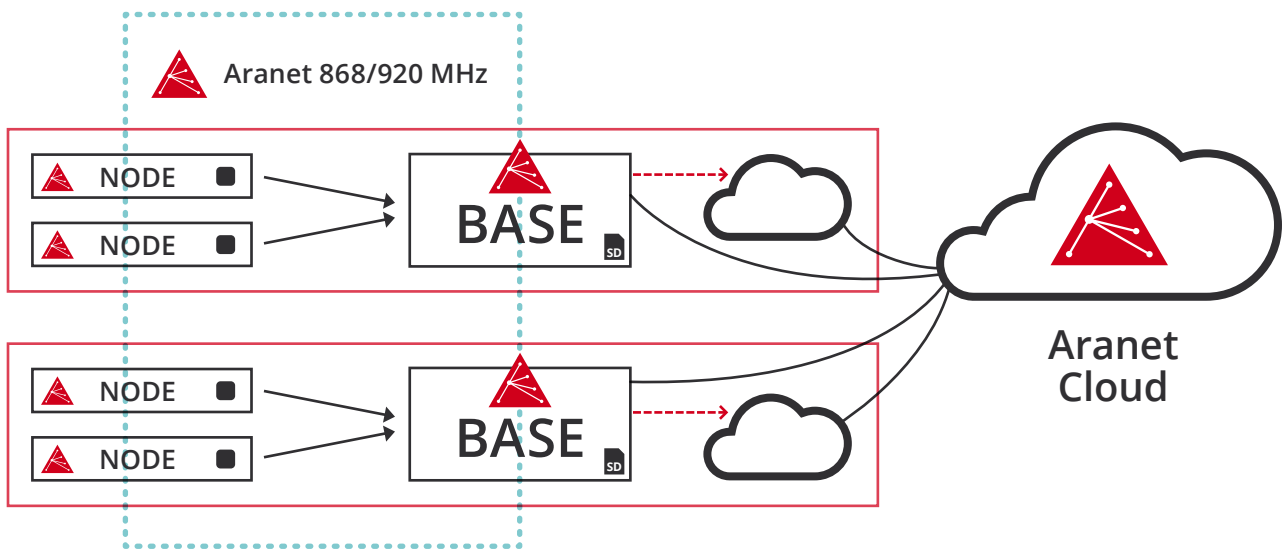

## There are several unique advantages to this kind of solution:

### SECURITY

As Aranet controls the whole network in its own secure encrypted communication protocol, there is no dependence on 3rd party cybersecurity flaws like password management or communication issues. You can have the whole system isolated from the rest of the world by hosting the cloud locally on your own infrastructure, making it completely off-grid secure.

### EASE OF USE

Having all Aranet system devices simplifies the setup: sensor pairing takes a few minutes and you are ready to go, even without any deep technical knowledge. In comparison, it takes time and technological expertise to set-up and program LoRaWAN sensors to work with LoRaWAN gateways. When rolling out large scale projects the fast setup really pays off.

### EXCELLENT SUPPORT

Aranet has a dedicated technical support team that helps you rapidly solve any problems should they arise. We take full responsibility for the whole communication chain of equipment. This means that you have a single and reliable point of contact for any potential issues.

### SAFETY

All of the elements are within a single software ecosystem, eliminating the risks of data transmission interoperability issues between different elements.

### OUTSTANDING BATTERY LIFE

Aranet sensors communicate with the base station unidirectionally. This allows them to be more power-efficient than the typical LoRa sensors.

### RELIABILITY

Aranet is manufactured by **SAF Tehnika**, a company with more than 20 years of experience in mission-critical radio equipment engineering. SAF's experience has allowed us to create the Aranet brand, which we believe to be the most reliable wireless sensor network currently on the market. The database, or SD memory card included in the Aranet base station also significantly improves the reliability of the solution.

Because of these reasons, the Aranet system really is a unique player in the wireless sensor market. So if you have limited resources for installation, you care about the network reliability and having a secure solution is important to you, **we highly recommend you give the Aranet solution a go.**



# Aranet.com

For more detailed information about Aranet products, please visit [www.aranet.com](http://www.aranet.com), contact your Aranet representative or write to [info@aranet.com](mailto:info@aranet.com). Product specifications are subject to change without prior notice. © 2021 SAF Tehnika, JSC. All rights reserved.