

VIKING PUMP[®]

INSTALLATION, OPERATION
AND
MAINTENANCE MANUAL
FOR THE

On-Line

And

Duralube[®]
VIKING BI-ROTOR PUMP

RANGE OF PUMPS

IDEX

Installation, Operation and Maintenance manual
for the On-Line range of rotary lobe pumps

Page No

<u>1.0</u>	<u>SAFETY INFORMATION.</u>	<u>4</u>
1.1	RISK ASSESSMENT RELATING TO THE USE OF VIKING PUMP ON-LINE ROTARY LOBE PUMPS AND PUMP UNITS IN POTENTIALLY EXPLOSIVE ATMOSPHERES.	7
<u>2.0</u>	<u>INTRODUCTION.</u>	<u>7</u>
2.1	GENERAL	8
2.2	VIKING PUMP HYGIENIC DISTRIBUTORS.	8
2.3	RECEIPTS AND STORAGE.	8
2.4	CLEANING.	9
2.5	PUMP MODEL DESIGNATION.	9
2.5.1	ATEX INFORMATION	10
2.5.2	EQUIPMENT GROUPS & CATEGORIES	10
2.6	PUMP MODEL AND SERIAL NUMBER.	11
2.7	STANDARD PUMP COMPONENT TERMS.	12
<u>3.0</u>	<u>GENERAL.</u>	<u>13</u>
3.1	ON LINE / DURALOBE PUMPING PRINCIPLE.	13
3.2	ON LINE / DURALOBE PUMP OPERATING PARAMETERS.	14
3.3	SYSTEM DESIGN.	15
3.3.1	SYSTEM DESIGN & INSTALLATION.	15
3.3.2	PUMP AND MOTOR ALIGNMENT	17
3.3.3	INSTALLATION WITH CIP SYSTEMS.	19
3.4	START UP PROCEDURE.	19
3.5	SHUTDOWN PROCEDURE.	20
3.6	ROUTINE MAINTENANCE – NON ATEX UNITS.	20
3.6.1	ADDITIONAL ROUTINE MAINTENANCE – ATEX UNITS.	21
3.7	HEATING AND COOLING DEVICES	21
3.8	INTEGRAL PRESSURE RELIEF VALVES	24
3.8.1	SETTING AND OPERATING SPRING LOADED VALVES	25
3.8.2	SETTING AND OPERATING AIR LOADED VALVE	26
<u>4.0</u>	<u>ON LINE / DURALOBE PUMP DISMANTLING AND ASSEMBLY.</u>	<u>33</u>
4.1	DISASSEMBLY.	34
4.1.1	FRONT COVER AND ROTOR REMOVAL	34
4.1.2	CARTRIDGE REMOVAL	36

4.1.3	CARTRIDGE DISASSEMBLY	37
4.2	ASSEMBLY.	38
4.2.1	CARTRIDGE ASSEMBLY	38
4.2.2	CARTRIDGE TO ROTORCASE ASSEMBLY	42
4.2.3	ROTOR ASSEMBLY AND SETTING ROTOR CLEARANCES	44
4.2.4	GEARBOX COVER ASSEMBLY	46
4.3	PRODUCT SEAL FITTING AND REMOVAL.	47
4.3.1	GENERAL PROCEDURES FOR FITTING MECHANICAL SEALS.	47
4.3.2	SINGLE MECHANICAL SEAL	48
4.3.3	SINGLE FLUSHED MECHANICAL SEAL	50
4.3.4	DOUBLE MECHANICAL SEAL	52
4.3.5	SINGLE O-RING SEAL	54
4.3.6	DOUBLE O-RING SEAL	55
4.3.7	TRAPPED SLEEVE	56
4.3.8	HYBRID DOUBLE MECHANICAL 2000 SEAL	57
4.3.09	HYBRID DOUBLE MECHANICAL SEAL	58
4.3.10	HYBRID SINGLE FLUSHED MECHANICAL SEAL	59
4.3.11	STRIP CLEAN SINGLE O-RING SEAL	60
4.3.12	DURALOBE SINGLE O-RING SEAL OL1 (S1)	61
4.3.13	DURALOBE SINGLE O-RING SEAL OL2, OL3, OL4 (S2, S3, S4)	62
4.3.14	MK2 DOUBLE O-RING SEAL OL1 (S1)	63
4.3.15	MK2 DOUBLE O-RING SEAL OL2, OL3, OL4 (S2, S3, S4)	64
4.3.16	FLUSHED PRODUCT SEAL - AUXILIARY SERVICES.	65
5.0	<u>SPECIFICATIONS.</u>	68
5.1	CLEARANCE CHART	68
5.2	FASTENERS & TORQUE SETTINGS.	69
5.3	LUBRICANTS.	70
5.4	MATERIAL SPECIFICATION.	70
5.5	ON LINE / DURALOBE FOUNDATION DIMENSIONS.	71
5.5	ON LINE / DURALOBE FOUNDATION DIMENSIONS.	72
5.6	TYPICAL BASIC PUMP BUILD.	73
5.7	TROUBLE SHOOTING.	74
5.8	TYPICAL NOISE EMISSION DATA.	75
5.9	SERVICE HISTORY.	76
5.10	TOOL LIST.	77
5.11	NOTES.	80

1.0 Safety Information.

INCORRECT INSTALLATION, OPERATION, OR MAINTENANCE OF EQUIPMENT MAY CAUSE SEVERE PERSONAL INJURY OR DEATH AND/OR EQUIPMENT DAMAGE AND MAY INVALIDATE THE WARRANTY.

THIS INFORMATION MUST BE READ FULLY BEFORE BEGINNING INSTALLATION, OPERATION, OR MAINTENANCE AND MUST BE KEPT WITH THE PUMP. SUITABLY TRAINED OR QUALIFIED PERSONS MUST UNDERTAKE ALL INSTALLATION AND MAINTENANCE ONLY.

Danger - Failure to follow the listed precautionary measures may result in serious injury or death are identified by the following symbol:



Warning - Safety instructions which shall be considered for reasons of safe operation of the pump or pump unit and/or protection of the pump or pump unit itself are marked by the sign:

WARNING

DANGER

DO NOT OPERATE PUMP IF:



- The front cover is not installed correctly.
- Any guards are missing or incorrectly installed.
- The suction or discharge piping is not connected.



DO NOT place fingers, etc. into the pumping chamber or its connection ports or into any part of the gearbox if there is ANY possibility of the pump shafts being rotated. Severe injury will occur.



DO NOT exceed the pumps rated pressure, speed, and temperature, or change the system/duty parameters from those for which the pump was originally supplied, without confirming its suitability for the new duty. Running the pump outside of its operating envelope can cause mechanical contact in the pump head, excessive heat and can represent a serious risk to health and safety.



Installation and operation of the pump must always comply with health and safety regulations.

A device must be incorporated into the pump, system, or drive to prevent the pump exceeding its stated duty pressure. It must be suitable for both directions of pump rotation where applicable. Do not allow pump to operate with a closed/blocked discharge unless a pressure relief device is incorporated. If an integral relief valve is incorporated into the pump, do not allow re-circulation through the relief valve for extended periods (refer to section 3.8).

WARNING



The mounting of the pump or pump unit should be solid and stable. Pump orientation must be considered in relation to drainage requirements. Once mounted, shaft drive elements must be checked for correct alignment. Rotate pump shaft by at least one full revolution to ensure smoothness of operation. Incorrect alignment will produce excessive loading and will create high temperatures and increased noise emissions. Do not use any drive arrangements that cause side loading of the drive shaft. It may also be necessary to earth the pump to avoid the build up of a potential charge difference that could cause a spark.



The installation must allow safe routine maintenance and inspection (to replenish lubricants, check for leakage, monitor pressures, etc) and provide adequate ventilation necessary to prevent overheating.

WARNING

Fill all gearboxes with the recommended grades and quantities of lubricant (refer to section 3.4). Beware of over/under filling the gearbox as this could cause the pump to over heat and mechanical damage to occur.

WARNING

Before operating the pump, be sure that it and all parts of the system to which it is connected are clean and free from debris and that all valves in the suction and discharge pipelines are fully opened. Ensure that all piping connecting to the pump is fully supported and correctly aligned with its relevant connections. Misalignment and/or excess loads will cause severe pump damage. This could result in unexpected mechanical contact in the pump head and has the potential to be a source of ignition.

WARNING

Be sure that pump rotation is correct for the desired direction of flow (refer to section 3.4).

WARNING

Do not install the pump into a system where it will run dry (i.e. without a supply of pumped media) unless it is equipped with a flushed shaft seal arrangement complete with a fully operational flushing system. Mechanical seals require a thin fluid film to lubricate the seal faces. Dry running can cause excessive heat and seal failure.

WARNING

Pressure gauges/sensors are recommended, next to the pump suction and discharge connections to monitor pressures.



Caution must be taken when lifting the pump. Suitable lifting devices should be used as appropriate. Lifting eyes installed on the pump must only be used to lift the pump, not pump with drive and/or base plate. If pump is base plate mounted, the base plate must be used for all lifting purposes. If slings are used for lifting, they must be safely and securely attached. For weights of bare shaft pumps refer to section 5.5.



DO NOT attempt any maintenance or disassembly of the pump or pump unit without first ensuring that:

- The pump is fully isolated from the power source (electric, hydraulic, pneumatic).
- The pumping chamber, pneumatic relief valve and any shaft seal support system are depressurised and purged.
- Any temperature control devices (jackets, heat-tracing, etc) are fully isolated, that they are depressurised and purged, and components are allowed to reach a safe handling temperature.



DO NOT attempt to dismantle a pressure relief valve, which has not had the spring pressure relieved, is still connected to a pressurised gas/air supply or is mounted on a pump that is operating. Serious personal injury or death and/or pump damage may occur.



DO NOT loosen or undo the front cover, any connections to the pump, shaft seal housings, temperature control devices, or other components, until sure that such action will not allow the unsafe escape of any pressurised media.

WARNING

Use only genuine Viking Pump Hygienic parts.

All certification, standards, guarantees & warranties originally supplied with this pump will be invalidated by the use of non-genuine Service Parts.



Pumps and/or drives can produce sound power levels exceeding 85-dB (A) under certain operating conditions. When necessary, personal protection against noise must be taken. Typical noise emission data can be found in section 5.8.



Avoid any contact with hot parts of pumps and/or drives that may cause injury. Certain operating conditions, temperature control devices (jackets, heat-tracing, etc.), bad installation, or poor maintenance can all promote high temperatures on pumps and/or drives.

WARNING

When cleaning, either manually or by CIP method, the operator must ensure that a suitable procedure is used in accordance with the system requirements.

During a CIP cleaning cycle, a pump differential pressure of between 2 and 3 bar (30 and 45 psi) is recommended to ensure suitable velocities are reached within the pump head. The pump must not be subjected to temperature change greater than 50°C/min. The exterior of the pump should be cleaned periodically.



Surface temperature of pump is also dependent on the temperature of pumped medium.

1.1 Risk assessment relating to the use of Viking Pump On-Line rotary lobe pumps and pump units in potentially explosive atmospheres.

Note:- For a feature to be suitable for an application, The feature must be fit for its designated purpose and also suitable for the environment where it is to be installed.

Source Of Hazards	Potential Hazards	Frequency Of Hazards	Recommended Measures
Unvented cavities	Build up of explosive gas	Very Rare	Ensure that pump is totally filled. Consider mounting ports vertically. See Chapter 1.0
Rotorcase / Rotors / Front Cover	Unintended mechanical contact	Rare	Ensure that operating pressures are not exceeded. Ensure that sufficient NPSH to prevent cavitation. See Chapter 1.0/3.4.1 Service plan.
Pump external surfaces	Excess temperature. Electrostatic charging	Rare	User must ensure temperature limits. Do not overfill gearboxes with lubricant. Provide a ground contact for pump. See Chapter 1.0/6.3 / Service plan.
Cover 'O' ring	Pump liquid leakage. Build up of explosive gas.	Very Rare	Check selection of elastomers are suitable for application. Ensure cover retaining nuts are tight. Service plan.
Pump casing / cover	Pump liquid leakage. Build up of explosive gas.	Very Rare	Stainless steel, Corrosion resistant.
Shaft seals	Excess temperature. Unintended mechanical contact. Leakage. Build up of explosive gas.	Rare	Selection of seal system must be suitable for application. See Chapter 5.0. Service plan. Seals must never run dry.
Auxiliary system for shaft sealing	Pump liquid leakage. Build up of explosive gas.	Rare	Selection of auxiliary seal system must be suitable for application. Seals must never run dry.
Rotation direction test	Excess temperature	Very Rare	If flushed seals are installed ensure that flush is applied to seal assemblies. Only allow pump to run for minimum period - just a few seconds.
Closed valve condition	Excess Temperature. Excess Pressure. Mechanical contact.	Rare	Can cause excessive pressure, heat and mechanical contact. See Chapter 1.0
Shaft	Random induced current	Very Rare	Provide a ground contact for pump. See Chapter 1.0.
Mechanical shaft coupling (Torque Protection)	Temperature from friction Sparks from break up of shear pins. Electrostatic charging	Rare	Coupling selection must suit application. See Chapter 1.0.
Mechanical shaft coupling (standard)	Break up of spider. Unintended mechanical contact. Electrostatic charging	Rare	Coupling selection must suit application. Service plan. See Chapter 1.0.

2.0 Introduction.

2.1 General

On Line / Duralobe rotary lobe pumps are manufactured by Viking Pump, a unit of IDEX Corporation.

This manual includes all the necessary information for On Line / Duralobe pumps and should be read prior to beginning installation, operation, or maintenance.

Should you require any additional information regarding the On Line / Duralobe pumps contact Viking Pump or their Viking Pump Hygienic authorised distributor, refer to section 2.2.

When asking for assistance please provide the pump model and serial number. This information can be obtained from the pump nameplate which is located on the side of the pump gearbox cover, refer to section 2.6.

Should the nameplate be unreadable or missing the serial number is also stamped on either side of the rotorcase refer to section 2.6.

If the system or product characteristics are to be changed from the original application for which the pump was selected, Viking Pump or their Viking Pump Hygienic authorised distributor should be consulted to ensure the pump is suitable for the new application.

2.2 Viking Pump Hygienic Distributors.

Viking Pump distributes its products internationally via a network of authorised distributors. Throughout this manual where reference is made to Viking Pump, service and assistance will also be provided by any Viking Pump Hygienic authorised distributor for On Line / Duralobe pumps.

2.3 Receipts and Storage.

Upon receipt of the pump, immediately examine it for any signs of visible damage. If any damage is noted, contact Viking Pump or your Viking Pump Hygienic authorised distributor and clearly mark upon the carriers' paperwork that the goods have been received in a damaged condition, with a brief description of damage.

If the pump is not required for immediate installation then it should be stored in a clean, dry environment. It is recommended that storage temperature should be between -10° and 40°C (14°F and 105°F).

2.4 Cleaning.

The On Line / Duralobe pump series is suitable for both manual cleaning and CIP (Cleaning In Place), refer to section 3.3.2.

The product seals are mounted directly behind the rotors and are designed and positioned to minimise product entrapment and maximise the effects of cleaning.

This strategic positioning of the product seals, combined with their ease of access provides an arrangement that can be more effectively cleaned by both manual and CIP procedures.

It is recommended that the exterior of the pump be cleaned periodically.

2.5 Pump Model Designation.

The designations of pump models are as follows:

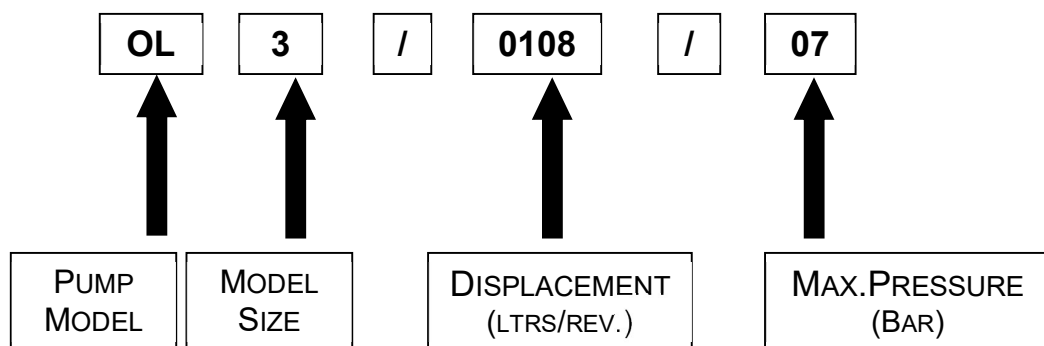
Online (Duralobe)

OL1/0004/15 (S1S)	OL3/0054/15 (S3S)
OL1/0006/10 (S1M)	OL3/0081/10 (S3M)
OL1/0008/07 (S1L)	OL3/0108/07 (S3L)
OL2/0017/15 (S2S)	OL4/0162/15 (S4S)
OL2/0025/10 (S2M)	OL4/0243/10 (S4M)
OL2/0034/07 (S2L)	OL4/0324/07 (S4L)

This information, together with the pump serial number, should be provided when requesting additional information on the pump or when ordering spare parts. The pump serial number is stamped on the pump nameplate and the rotorcase, (refer to section 2.6, Figs 2 and 3).

For the maximum operating pressures, temperatures and speeds refer to section 3.2, Fig 6.

Fig 1 for European models only.



2.5.1 ATEX Information

ATEX Pump Requirements

Mechanical seals are a source of heat and must never be allowed to run dry. We would recommend provision be made to ensure that there is always flow or fluid around the pump seals. If there is a risk of the supply being interrupted, then a temperature monitoring system must be applied to ensure the pump does not exceed the ATEX rating. The surface temperature of the pump is dependent on the temperature of the pumped fluid and a due account of this should be taken whilst undertaking your risk assessment of the installation. These pumps are ATEX rated T3.

WARNING

Only use genuine spare parts that have been designed and verified ATEX compliant by Viking Pump Hygienic, failure to use genuine spare parts will invalidate the ATEX certification.

WARNING

Pumps that have the ATEX certification will have an earthing point on the front cover, this needs to be electrically earthed before use.

WARNING

The service and maintenance intervals are increased on certified ATEX units, refer to section 3.6.1 for the required routine maintenance. Failure to maintain the pumps to these intervals will result in the ATEX certification being invalidated.

WARNING

When installing the unit make sure so far as reasonably practicable that the pump is aligned within 5 degrees to the horizontal – failure to align the unit could adversely affect the gearbox lubrication and could cause heat to build up.

It is the end user's responsibility to ensure that the ATEX rating of the equipment supplied meets the requirements of the installation.

2.5.2 Equipment Groups & Categories

The pump range has been rated as



h II – 2 – G/D TEMP – T3

Temperature Class T3

Group II.

Category 2

Unit is suitable for environments containing dust or gas G/D

Equipment-groups (Annex I of the EC-Directive 94/9/EC)							
Group I (mines, mine gas and dust)		Group II (other explosive atmospheres gas/dust)					
Category M		Category 1		Category 2		Category 3	
1	2	G (gas) (Zone 0)	D (dust) (Zone 20)	G (gas) (Zone 1)	D (dust) (Zone 21)	G (gas) (Zone 2)	D (dust) (Zone 22)
for equipment providing a very high level of protection when endangered by an explosive atmosphere	for equipment providing a high level of protection when likely to be endangered by an explosive atmosphere	for equipment providing a very high level of protection when used in areas where an explosive atmosphere is very likely to occur		for equipment providing a high level of protection when used in areas where an explosive atmosphere is likely to occur		for equipment providing a normal level of protection when used in areas where an explosive atmosphere is less likely to occur	

2.6 Pump Model and Serial Number.

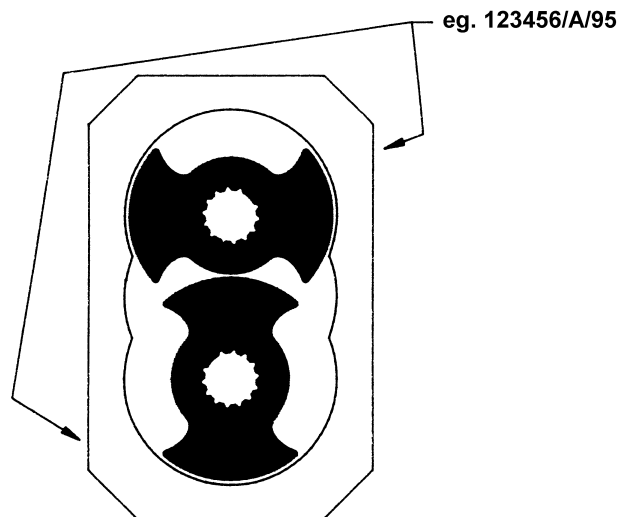
Should you require any information regarding your On Line / Duralobe rotary lobe pump contact Viking Pump or your Viking Pump Hygienic authorised distributor, providing the pump model and serial number as stated on the pump nameplate, see Fig 2, which is fixed to the pump gearbox cover.

Should this be damaged or missing, the pump serial number is also stamped on opposite corners of the rotorcase, (see Fig 3).

Fig 2

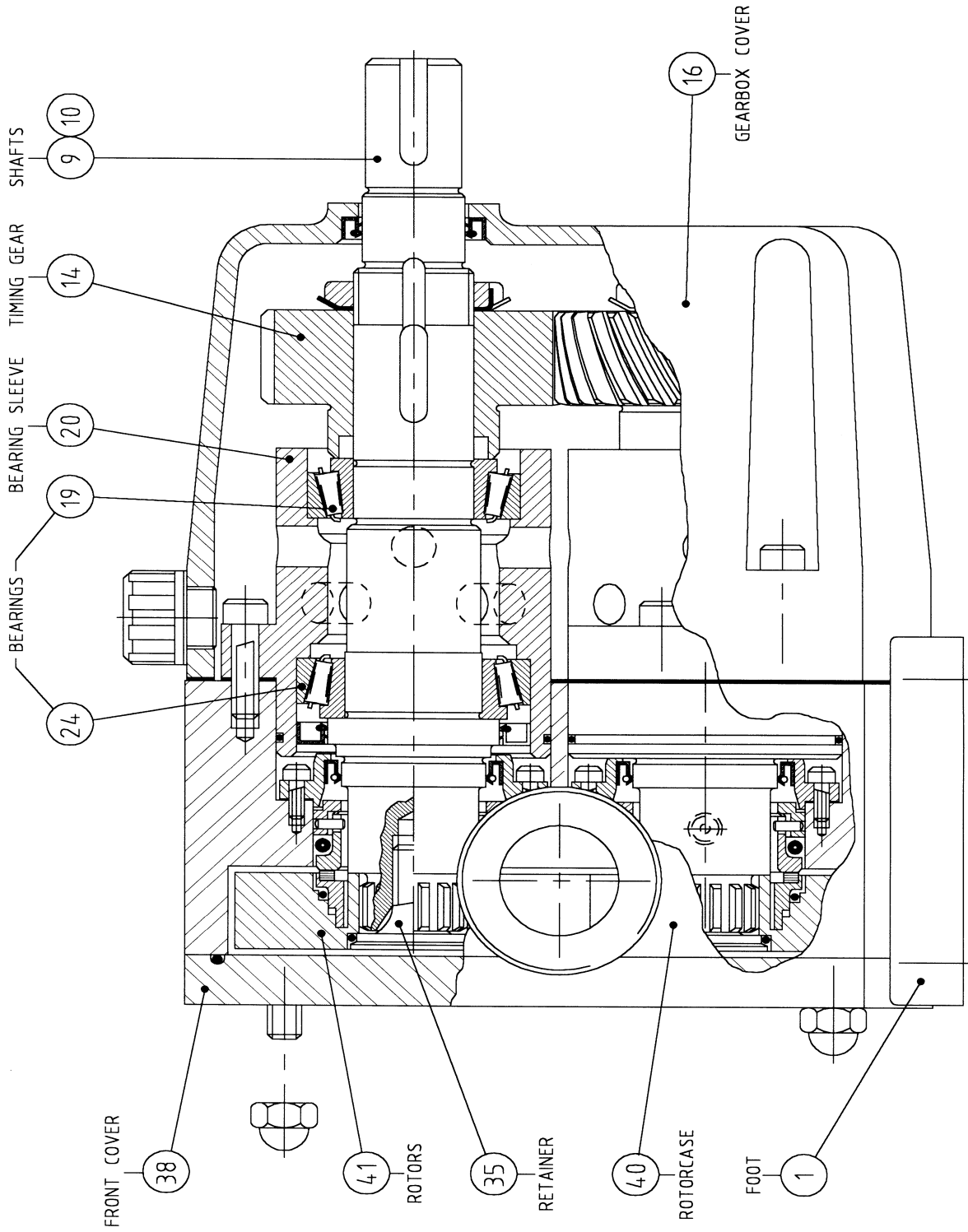


Fig 3



2.7 Standard Pump Component Terms.

Fig 4



3.0 General.

3.1 On Line / Duralobe Pumping Principle.

The pumping action of the rotary lobe pump principle is generated by the contra-rotation of two pumping elements (rotors) within a chamber (rotorcase) see Fig 5.

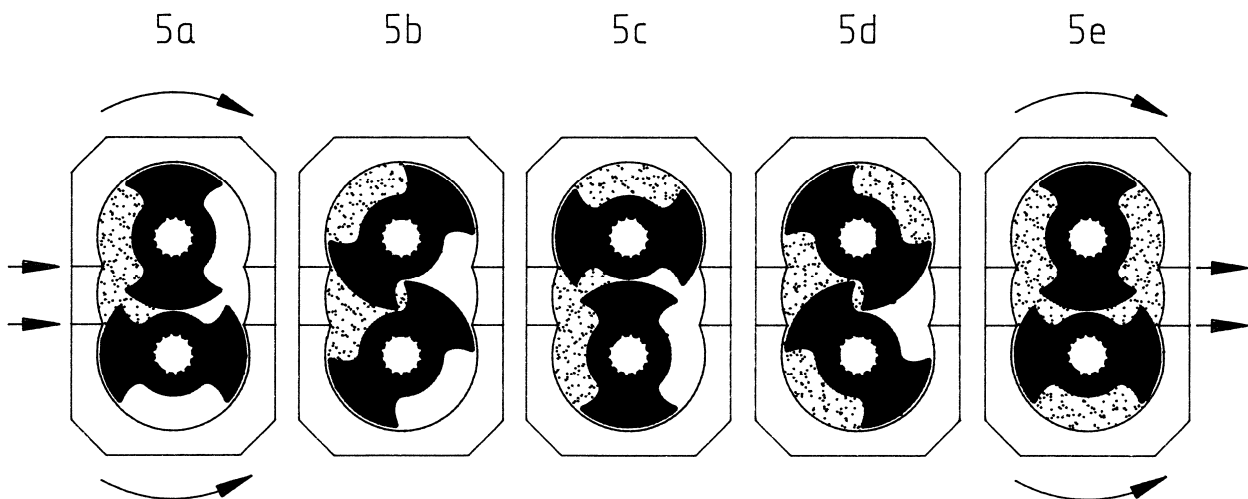
The rotors are located on shafts that in turn are held within two cartridges mounted onto the back of the rotorcase. The shaft cartridge assemblies comprise of, the shaft support bearings and the timing gears. The gears transfer the energy from the drive shaft to the driven shaft, synchronising the rotors such that they rotate without contact with each other.

As the rotors pass the suction port, Fig 5a, the cavity increases creating a pressure decrease, which induces the pumped medium to flow into the rotorcase.

The pumped medium is carried around the rotorcase by the rotors, Fig 5b and 5c, to the discharge side of the pump, Fig 5d. Here the cavity decreases and the pumped medium is discharged from the rotorcase, Fig 5e.

For pump component terms see Fig 4.

Fig 5 Rotary Lobe Pump Principle.



3.2 On Line / Duralobe Pump Operating Parameters.

Fig 6

Pump Series	Theoretical Displacement			Nominal Connection Size		Max Diff. Pressure		Max Speed	Max Temp	Max Temp
	Litre/rev	Imp. gal /100 rev	US gal /100 rev	mm	inches	Bar	psi	rev/min	°C	°F
OL1/0004/15 (S1S)	0.04	0.88	1.06	25	1	14	200	1150	150	300
OL1/0006/10 (S1M)	0.06	1.32	1.59	25	1	10	150	1150	150	300
OL1/0008/07 (S1L)	0.08	1.76	2.11	25	1	7	100	1150	150	300
OL2/0017/15 (S2S)	0.17	3.74	4.49	38	1.5	14	200	1150	150	300
OL2/0025/10 (S2M)	0.25	5.50	6.61	50	2	10	150	1150	150	300
OL2/0034/07 (S2L)	0.34	7.48	8.98	50	2	7	100	1150	150	300
OL3/0054/15 (S3S)	0.54	11.88	14.27	50	2	14	200	870	150	300
OL3/0081/10 (S3M)	0.81	17.82	21.40	76	3	10	150	870	150	300
OL3/0108/07 (S3L)	1.08	23.76	28.53	76	3	7	100	870	150	300
OL4/0162/15 (S4S)	1.62	35.64	42.80	76	3	14	200	700	150	300
OL4/0243/10 (S4M)	2.43	53.46	64.20	101	4	10	150	700	150	300
OL4/0324/07 (S4L)	3.24	71.28	85.60	101	4	7	100	700	150	300

The maximum pressure and speed operating parameters are given in Fig 6. In practice these may be limited due to the nature of the product to be pumped and/or design of the system in which the pump is to be installed. Consult Viking Pump or your Viking Pump Hygienic authorised distributor for assistance.

WARNING

If the system or product characteristics are to be changed from the original application for which the pump was selected, Viking Pump or their Viking Pump Hygienic authorised distributor should be consulted to ensure the pump is suitable for the new application.

The pump should not be subjected to sudden temperature changes to avoid the risk of damage from sudden expansion/contraction of components. Care should be taken when selecting pumps for handling liquids containing abrasive particles as these may cause wear of pump head components. For advice or assistance contact Viking Pump or your Viking Pump Hygienic authorised distributor.

3.3 System Design.

3.3.1 System Design & Installation.

When incorporating any pump into a system it is considered good practice to minimise piping runs and the number of fittings (tees, unions, bends etc.) and restrictions. Particular care should be taken in designing the suction line, which should be as short and straight as possible with a minimum of pipe fittings to minimise restricting product flow to the pump. The following should be considered at the design stage of any system:



- i) Be sure ample room is provided around the pump to allow for:
 - a) Access to the pump and drive for routine inspection and maintenance, i.e. to replenish pump or drive lubricant or to remove pump front cover and rotors.
 - b) Ventilation of the drive to prevent over heating.
- ii) The pump must not be used to support piping. All piping to and from the pump unit must be independently supported. Failure to observe this may distort the pump head components or assembly and cause serious consequential damage to the pump.
- iii) Valves should be provided adjacent to the pump suction and discharge connections to allow the pump to be isolated from the system for routine inspection and maintenance.

WARNING



- iv) Rotary lobe pumps are of the positive displacement type and therefore an overload protection device must be provided. This can take the form of:
 - a) A pressure relief valve integral with the pump where available and suited to the application, refer to section 3.8.
 - b) An in-line pressure relief system, i.e. external to the pump.
 - c) Incorporation of a torque-limiting device in the drive system.
 - d) Rupture disc incorporated in the discharge piping.

Where pump rotation and hence flow is to be reversed during normal operation, the overload device must be capable of protection for both directions of rotation/flow. The On Line / Duralobe integral relief valves are described in section 3.8 and are designed to operate under such conditions.

WARNING

v) It is recommended that all piping and associated equipment from the tank to the discharge point be thoroughly cleaned before installation of the pump to avoid debris entering the pump and causing damage.

WARNING

vi) Pressure gauges should be installed adjacent to the pump suction and discharge connections such that system pressures can be monitored. These gauges will provide a clear indication of changes in operating conditions and where a relief valve is incorporated in the system, will be necessary for setting and checking the functioning of the valve.

WARNING

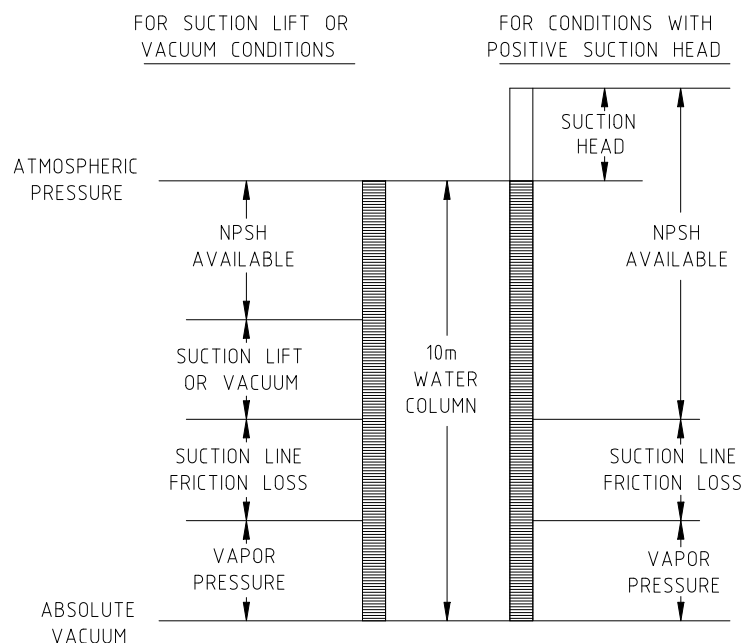
vii) It is imperative that the suction condition at the pump inlet meets the Net Positive Suction Head Required (NPSHr) by the pump. Failure to observe this could cause cavitation, resulting in noisy operation, reduction in flow rate and mechanical damage to the pump and associated equipment.

WARNING

The Net Positive Suction Head Available (NPSHa) from the system must always exceed the Net Positive Suction Head Required (NPSHr) by the pump. Observing the following general guidelines should ensure the best possible suction condition is created.

- Suction piping is at least the same diameter as the pump connections.
- The length of suction piping is kept to the absolute minimum. With the minimum number of bends, tees, and pipe work restrictions are used.
- Calculations to determine system NPSHa are carried out for the worst condition see Fig 7.
- Should advice on pump or system NPSH characteristics be required contact Viking Pump or their Viking Pump Hygienic authorised distributor.

Fig 7



(viii) When installing a pump complete with baseplate, motor and drive the following guidelines must be observed:

a) The preferred drive arrangement for any rotary lobe pump is in-line direct coupled. If an alternative is required please contact Viking Pump or your Viking Pump Hygienic authorised distributor.



b) Flexible couplings must always be incorporated and correctly aligned within the limits recommended by the coupling manufacturer. To check coupling alignment rotate the shaft by at least one full revolution and ensure that the shaft rotates smoothly. Couplings of a non-flexible design must never be used.



c) Couplings must always be enclosed in a suitable guard to prevent contact with rotating parts that could result in personal injury. Guards should be of suitable material, (see d) and of sufficiently rigid design to prevent contact with rotating parts under normal operating conditions.



d) When installing pump sets in flammable or explosive environments, or for handling flammable or explosive materials. Special consideration must be given not only to the safety aspects of the drive unit enclosure but also to the materials used for both the coupling and the guard to eliminate the risk of explosion.



e) Base plates must be secured to a flat level surface such that distortion and misalignment are avoided. Once base plates are fastened in position the drive alignment must be re-checked, (see b).

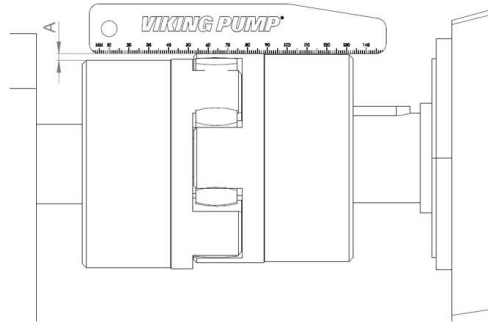


f) When using electric motor drives, ensure that the electrical supply is compatible with the drive and controls and that the method of wiring is correct for the type of starting required by the motor i.e. Direct On Line, or other similar method. Ensure all components are correctly grounded.

3.3.2 Pump and Motor Alignment

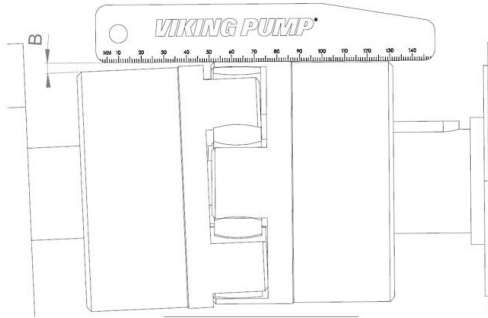
Before the pump unit is installed it is important to ensure that the mounting surface is flat to avoid distortion of the baseplate, which may cause pump/motor shaft misalignment and pump/motor unit damage. Once the baseplate has been secured, the pump shaft to motor shaft coupling alignment should be checked and adjusted as necessary. This is achieved by checking the maximum angular and parallel misalignment for the couplings as stated below, the recommended couplings are KTR Rotex. Shaft alignment that is outside the stated tolerances can be corrected by applying shims under the motor or pump foot, or, by moving the pump or driving sideways on the baseplate. All bolts that have been loosened should be re-tightened to the stated torque figure.

Radial tolerance: - Measure 4 positions at 90° around coupling



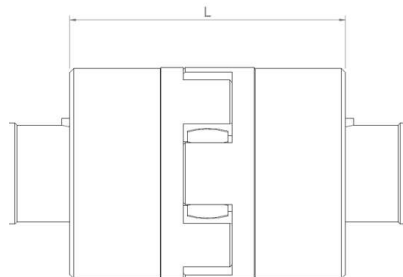
Size RX	14	19	24	28	38	42	48	55	65	75	90	100	110	125	140	160	180
Max. Radial (mm) Displacement "A" upto 1500 RPM	0.17	0.22	0.22	0.25	0.28	0.32	0.36	0.38	0.42	0.48	0.5	0.52	0.55	0.6	0.62	0.64	0.68
Max. Radial (Inch) Displacement "A" upto 1500 RPM	0.007	0.009	0.009	0.010	0.011	0.013	0.014	0.015	0.017	0.019	0.020	0.020	0.022	0.024	0.024	0.025	0.027

Angular tolerance: - Measure 4 positions at 90° around coupling



Size RX	14	19	24	28	38	42	48	55	65	75	90	100	110	125	140	160	180
Max. Angular (°) Displacement "B" upto 1500 RPM	1.1	0.8	0.8	0.9	0.9	0.9	1.0	1.0	1.1	1.1	1.1	1.1	1.2	1.0	1.1	1.1	1.1

Length Tolerance:-



Size RX	14	19	24	28	38	42	48	55	65	75	90	100	110	125	140	160	180
Dimension L ± 1.0mm 1500 RPM	35	66	78	90	114	126	140	160	185	210	245	270	295	340	375	425	475
Dimension L ± 0.039" 1500 RPM	1.378	2.598	3.071	3.543	4.488	4.961	5.512	6.299	7.283	8.268	9.646	10.630	11.614	13.386	14.764	16.732	18.701

3.3.3 Installation with CIP Systems.

The On Line / Duralobe has been designed to be effectively cleaned by the CIP procedures recommended for in place cleaning of process equipment. It is recommended that a differential pressure of 2 to 3 bar (30 to 45 psi) be developed across the pump head during cleaning in order to develop the necessary fluid velocities required for thorough cleaning. The pump must not be subjected to temperature change greater than 50°C/min.

3.4 Start Up Procedure.

WARNING Check that all piping and associated equipment are clean and free from debris and that all pipe connections are secure and leak free.

WARNING For pumps installed with flushed product seals check that all auxiliary services are in place and connected and provide sufficient flow and pressure for flushing purposes, refer to section 4.3.7.

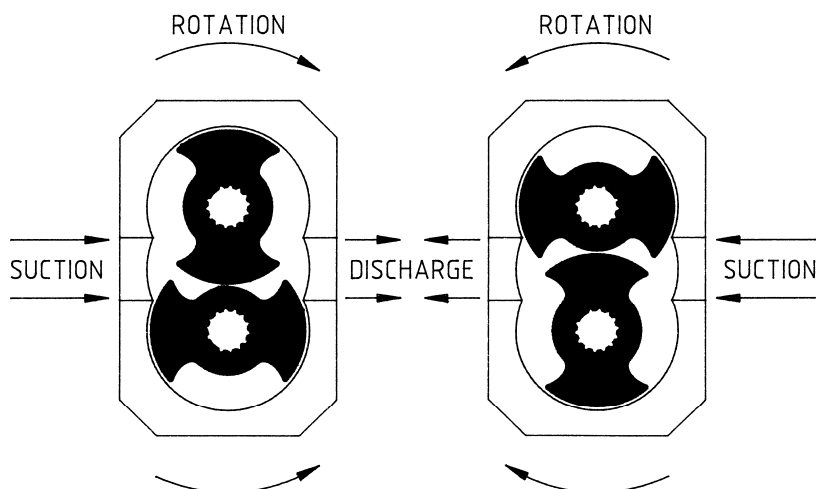
WARNING Ensure lubrication is provided for both pump and drive. On Line / Duralobe pumps are shipped without oil as standard and should be filled to the level of the oil sight glass that must be installed in the upper tapped hole in the side of the gearbox cover, refer to section 5.3 for oil capacities and grades.

WARNING If an external relief valve is incorporated in the system check that it is set correctly. For start up purposes it is considered good practice to set the relief valve lower than the system design pressure. On completion of start up the relief valve should be set for the application. The required setting should never exceed the lower of either the pumps maximum pressure rating or the system design pressure. For setting integral relief valves, refer to sections 3.8.1 and 3.8.2.

WARNING Ensure both suction and discharge valves are fully open, and pipe work is free from all obstructions. On Line / Duralobe pumps are of the positive displacement type and should therefore never be operated against a closed valve as this would result in pressure overload, resulting in damage to the pump and possibly the system.

WARNING Ensure rotation of the drive shaft is correct for the direction of flow required see Fig 8.

Fig 8





Ensure product is available in the tank before starting pump. This is very important for pumps installed with un-flushed product seals, as these sealing arrangements must never be allowed to run dry.

Before beginning operation it is considered good practice to momentarily start/stop the pump to check the direction of rotation and ensure that the pump is free of obstructions. Once this has been carried out, begin operation keeping a visual check on suction and discharge pressure gauges and monitor pump temperature and power absorbed where possible.

3.5 Shutdown Procedure.



When shutting the pump down close both the suction and discharge valves and ensure that the necessary safety precautions are taken:

- The prime mover power source has been isolated.
- If installed, the pneumatically operated integral relief valve has been depressurised.
- If installed, flushed product seal auxiliary services have been isolated and depressurised.
- Pump head and piping have been drained and purged.

3.6 Routine Maintenance – Non Atex units.

Oil

WARNING

- Check oil levels regularly.
- Change the oil every 12 months or 3000 operating hours, whichever is the sooner.

For lubricant capacities and grades refer to section 5.3.

Seal Replacement Interval:

It is recommended that the Rotor Retainer O-ring seal is replaced every 12 months to maintain a bacteria-tight seal.

Rotor Retainer Seal Inspection:

Periodically inspect the Rotor Retainer O-ring seal for any discolouration, nicks, or cracks. If any of the defects above are noticed, the O-ring seal must be replaced. Inspection and replacement refer to the seal replacement procedure.

3.6.1 Additional Routine Maintenance – Atex units.

Oil

WARNING

- Check oil levels on startup.
- Check for any signs of overheating.
- Change the oil every 6 months or 1500 operating hours, whichever is the sooner.

For lubricant capacities and grades refer to section 5.3.

After 14000 hours of use, the pump will need a general overhaul and it will need to be re-certified for use within the Atex environment.

WARNING

A general overhaul must include a full disassembly of all components and the following work carried out.

- Clean all pump components
- Examination of all components for damage/wear
- Replacement of all taper roller bearings
- Replacement of all elastomeric components
- Replacement of all seals, radial seals, and Gamma rings

The general overhaul must be carried out by qualified personnel in a specialist workshop with the appropriate equipment. Re-certification must then be carried out.

We highly recommend that the general overhaul is carried out by Viking Pump.

3.7 Heating and Cooling Devices

See Figs 9 and 10.

All On Line / Duralobe models except the OL1 (S1) series can be supplied with a jacketed front cover and rotorcase with ports for circulation of a heating/cooling media.

The jacketed front cover and rotorcase heating and cooling ports are strategically positioned such that the required thermal effect acts on the pumping chamber and product seal area.

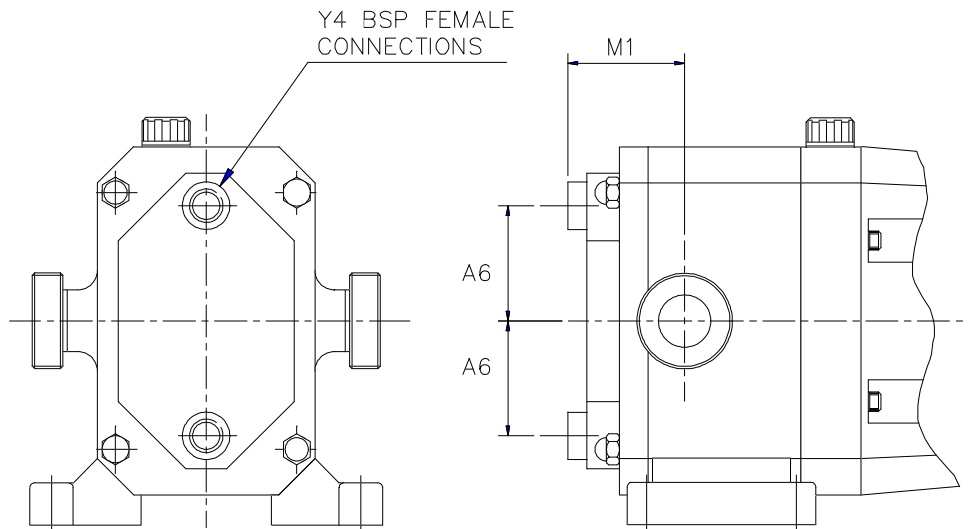


The pressure rating of the On Line / Duralobe series jacketed front cover and rotorcase heating/cooling ports is (3.5 bar g) 50 psi and should not be exceeded without consulting Viking Pump or your Viking Pump Hygienic authorised distributor.

Heating/cooling of the pump head is used to maintain, rather than increase /decrease the temperature of the pumped media and should be used as part of a complete system where suction and discharge lines and vessels are also heated /cooled.

Where heating/cooling devices are employed, the heating/cooling media should be circulated 15-20 minutes prior to pump start-up and should be allowed to continue for a similar period of time after the pump has been shutdown. Where a CIP cycle is employed as part of the process, the heating/cooling media should continue to be circulated during the cleaning cycle.

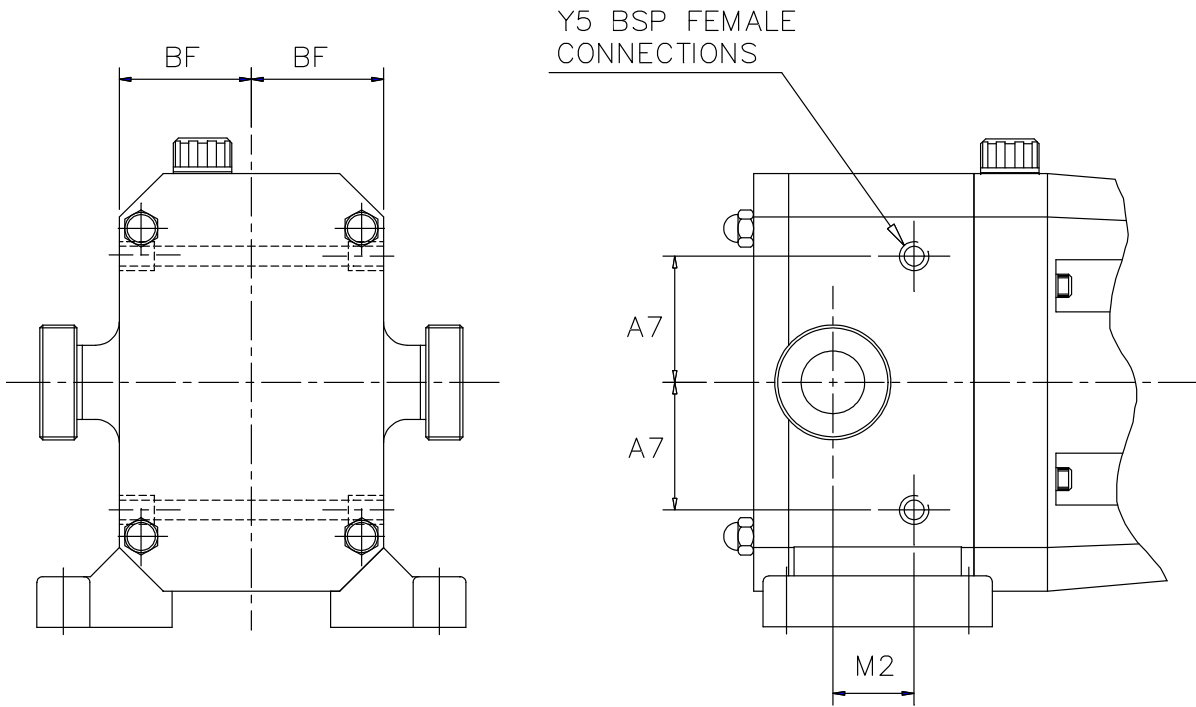
Fig 9 Dimensions of Front Cover Jacket for Heating/Cooling



Model	Millimetres		Inches		Y4
	A6	M1	A6	M1	
OL1/0004/15 (S1S)	45.0	52.0	1.77	2.05	1/4
OL1/0006/10 (S1M)	45.0	54.0	1.77	2.13	1/4
OL1/0008/07 (S1L)	45.0	54.5	1.77	2.15	1/4
OL2/0017/15 (S2S)	70.0	70.0	2.76	2.76	1/2
OL2/0025/10 (S2M)	70.0	75.0	2.76	2.95	1/2
OL2/0034/07 (S2L)	70.0	76.0	2.76	2.99	1/2
OL3/0054/15 (S3S)	105.0	95.0	4.13	3.74	1/2
OL3/0081/10 (S3M)	105.0	104.0	4.13	4.09	1/2
OL3/0108/07 (S3L)	105.0	104.0	4.13	4.09	1/2
OL4/0162/15 (S4S)	150.0	113.0	5.91	4.45	1/2
OL4/0243/10 (S4M)	150.0	126.0	5.91	4.96	1/2
OL4/0324/07 (S4L)	150.0	133.0	5.91	5.24	1/2

Note: For all other dimensions see section 5.5, Foundation Dimensions, and Weights.

Fig 10 Dimensions for Rotorcase Ports for Heating/Cooling.



Model	Millimetres			Inches			Y5
	A7	BF	M2	A7	BF	M2	
OL1/0004/15 (S1S)	N/A	N/A	N/A	N/A	N/A	N/A	N/A
OL1/0006/10 (S1M)	N/A	N/A	N/A	N/A	N/A	N/A	N/A
OL1/0008/07 (S1L)	N/A	N/A	N/A	N/A	N/A	N/A	N/A
OL2/0017/15 (S2S)	80.0	66.5	14.0	3.15	2.62	0.55	1/8
OL2/0025/10 (S2M)	80.0	66.5	24.5	3.15	2.62	0.96	1/8
OL2/0034/07 (S2L)	80.0	66.5	36.0	3.15	2.62	1.42	1/8
OL3/0054/15 (S3S)	102.5	90.5	16.0	4.04	3.56	0.63	1/8
OL3/0081/10 (S3M)	102.5	90.5	25.0	4.04	3.56	0.98	1/8
OL3/0108/07 (S3L)	102.5	90.5	49.0	4.04	3.56	1.93	1/8
OL4/0162/15 (S4S)	140.0	137.0	22.0	5.51	5.39	0.87	1/8
OL4/0243/10 (S4M)	140.0	137.0	35.0	5.51	5.39	1.38	1/8
OL4/0324/07 (S4L)	140.0	137.0	64.0	5.91	5.24	2.52	1/2

Note: For all other dimensions see section 5.5, Foundation Dimensions, and Weights.

3.8 Integral Pressure Relief Valves See Figs 11, 12, 13, and 14.

All models in the On Line / Duralobe series can be supplied with integral pressure relief valves with both spring and air loaded versions available. The function of the valves can be further enhanced with the option of manual or airlift override offering particular benefits where CIP or SIP is employed. Valves incorporating this option can be opened to regulate the volume of the cleaning media within the pump chamber thereby avoiding the need for manual cleaning or external by-pass.

Where the pump is mounted onto a portable baseplate complete with motor and drive to be used as a mobile set, it is strongly recommended that a integral pressure relief valve is installed.

The On Line / Duralobe integral pressure relief valves available include:

Spring Loaded - see Fig 11 & 12.5

Valve can be set to required pressure relief setting.

Spring Loaded with Manual Lift - see Fig 12.

Valve can be set to required pressure relief setting. Manual lift override can be used to open valve without disturbing pressure relief setting

Spring loaded with airlift - see Fig 13.

Valve can be set to required pressure relief setting. Airlift override, which operates on an air supply of up to 105-psi depending on pressure relief setting, can be used to open valve without disturbing pressure relief setting

Air loaded with airlift - see Fig 14.

Valve, which operates on an air supply of up to 7 Bar (100 psi) for OL1, OL2, OL3, (S1, S2, S3) and 10 Bar (145 psi) for OL4 (S4), can be set to required pressure relief setting. Airlift override, which operates on an air supply of up to 7 Bar (100 psi) for OL1, OL2, OL3, (S1, S2, S3) and 10 Bar (145 psi) for OL4 (S4), depending on pressure relief setting, can be used to open valve without disturbing pressure relief setting.

Air actuated relief valves can be operated remotely and interfaced with other elements of the system or process control.

WARNING

Integral pressure relief valves are normally used to protect the pump from the effects of increases in system pressure caused, for example, by a restricted or closed discharge line. In response to a pressure increase the valve opens and internally circulates the pumped media within the pump chamber. When the valve opens, because the volume of fluid circulating is relatively small, the temperature of the fluid in the pump chamber may rise if the pump continues to operate for an extended period. In severe cases this may result in temperatures in excess of the pumps operating limits or vaporisation of the fluid, both of which should be avoided. For these reasons when the valve is activated the cause of the system pressure increase should be eliminated as continuous operation of the pump with the valve open is not recommended and may cause severe damage to the pump.

If the pump on which the valve is installed is to be installed in either a pressurised system or one incorporating a vessel under vacuum, the application of the valve should be referred to Viking Pump or their Viking Pump Hygienic authorised distributor.

The selection, setting and application of integral relief valves is influenced by the viscosity and nature of the pumped media, the pump operating speed and the required pressure relief setting and mode of operation. For these reasons, and to cover the diverse range of products, the conditions under which they are pumped, and application demands, it is not practical to factory set integral relief valves. The setting of the valve should be carried out on site under the proposed duty conditions for which the pump and valve were selected.

For setting and operating On Line / Duralobe integral relief valves refer to sections 3.8.1 and 3.8.2. Before beginning the relief valve setting procedure the pump should be installed, refer to section 3.3.1, with a pressure gauge in the discharge line adjacent to the pump discharge port.

3.8.1 Setting and Operating Spring Loaded Valves See Figs 11, 12 and 13.



- Remove cover (108). For integral relief valve with manual lift, see Fig 12; first remove nut (129) and hand wheel (111).
- Loosen nut (107) using a pry bar in the holes provided, to relieve spring compression. For integral relief valve with airlift, see Fig 13, the air cylinder must be exhausted prior to unscrewing the nut (107).
- Start pump, refer to section 3.4.
- Screw in nut (107) using pry bar in holes provided until required pressure relief setting is reached.

WARNING

Note: Care should be taken not to exceed the lower of either the pumps maximum pressure rating or the system design pressure.

- Reinstall cover (108). For integral relief valve with manual lift, see Fig 12; reinstall hand wheel (111) and nut (129).
- The relief valve is now set.

For Integral Relief Valve with Manual Lift - see Fig 12.

- To operate the manual lift, turn the hand wheel (111) clockwise, which will lift the valve head (102/128). To resume normal operation turn the hand wheel (111) counter-clockwise.

For Integral Relief Valve with airlift - see Fig 13.

- To actuate the air lift connect an air supply not exceeding 7 Bar for OL1, OL2, OL3 (S1, S2, S3) and 10 Bar for OL4 (S4) to the cylinder (123) which will lift the valve head (112). To resume normal relief valve operation, exhaust the cylinder (123).

3.8.2 Setting and Operating Air Loaded Valve See Fig 14.

- Connect an air supply, via a regulating valve to the relief valve connection A in the cylinder (114). Do not turn on the air supply.
- Start the pump, refer to section 3.4.
- Using the regulating valve gradually increase the air pressure until required pressure relief setting is reached. The air pressure must not exceed 7 Bar OL1, OL2, OL3, (S1, S2, S3) and 10 Bar OL4 (S4).
- The relief valve is now set.
- **OL4 (S4) Only - If the valve assembly is disassembled, e.g. for maintenance or repair, it is necessary to apply a thread locking compound (Loctite 270 or similar) to the piston retaining screw (120).**

WARNING

Note: Care should be taken not to exceed the lower of either the pumps maximum pressure rating or the system design pressure.

- To use the air lift system the regulated air supply must be routed through a change over valve in order to transfer air from the relief valve load air chamber, connection A, to the lift air chamber, connection B while depressurising the load chamber and vice versa. The change over valve will actuate the air lift which will lift when the air supply is diverted to connection B, and will close, restoring normal relief valve operation, when the air supply is diverted back to connection A.

Danger



Under no circumstances should any attempt be made to dismantle a pressure relief valve which has not had the spring pressure relieved, is still connected to a pressurised air supply, or is mounted on a pump that is operating. Serious personal injury or pump damage may occur.

Fig 11 Spring Loaded Integral Pressure Relief Valve OL1, OL2, OL3 (S1, S2, S3) Typical.

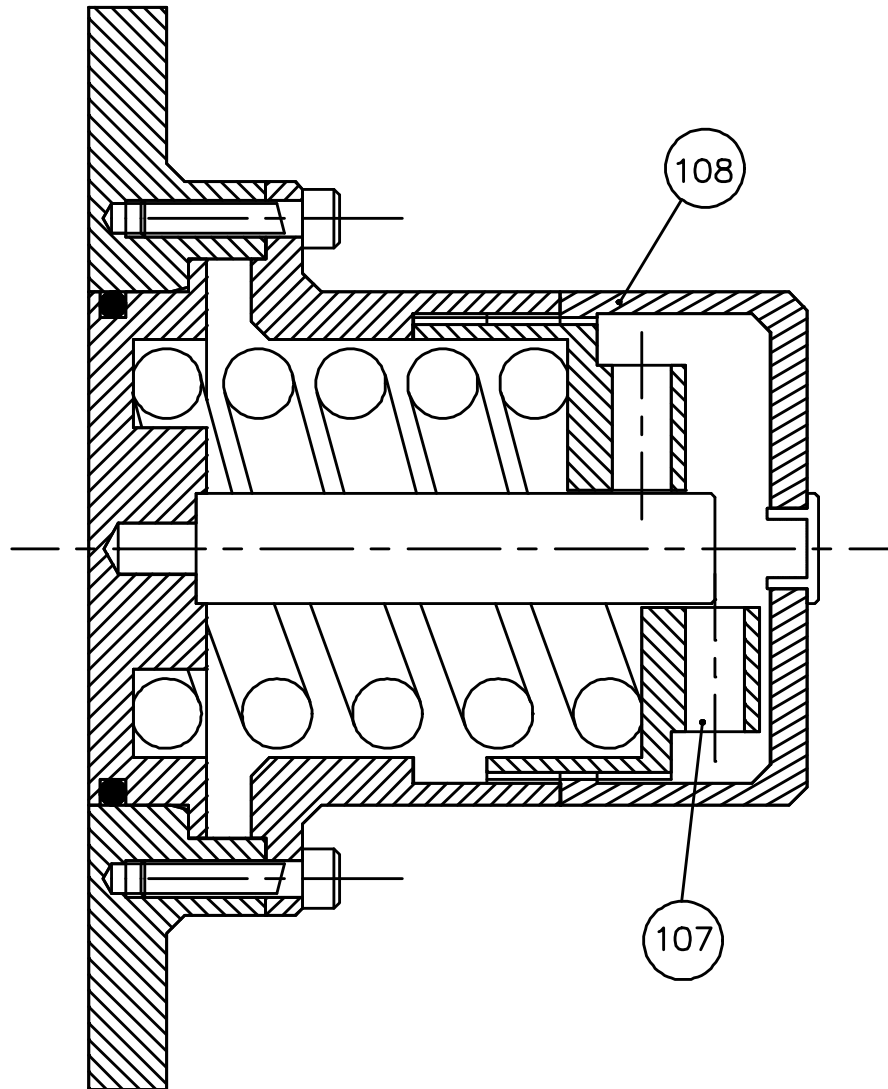


Fig 12 Spring Loaded Integral Pressure Relief Valve with Manual Lift
OL1, OL2, OL3 (S1, S2, S3) Typical.

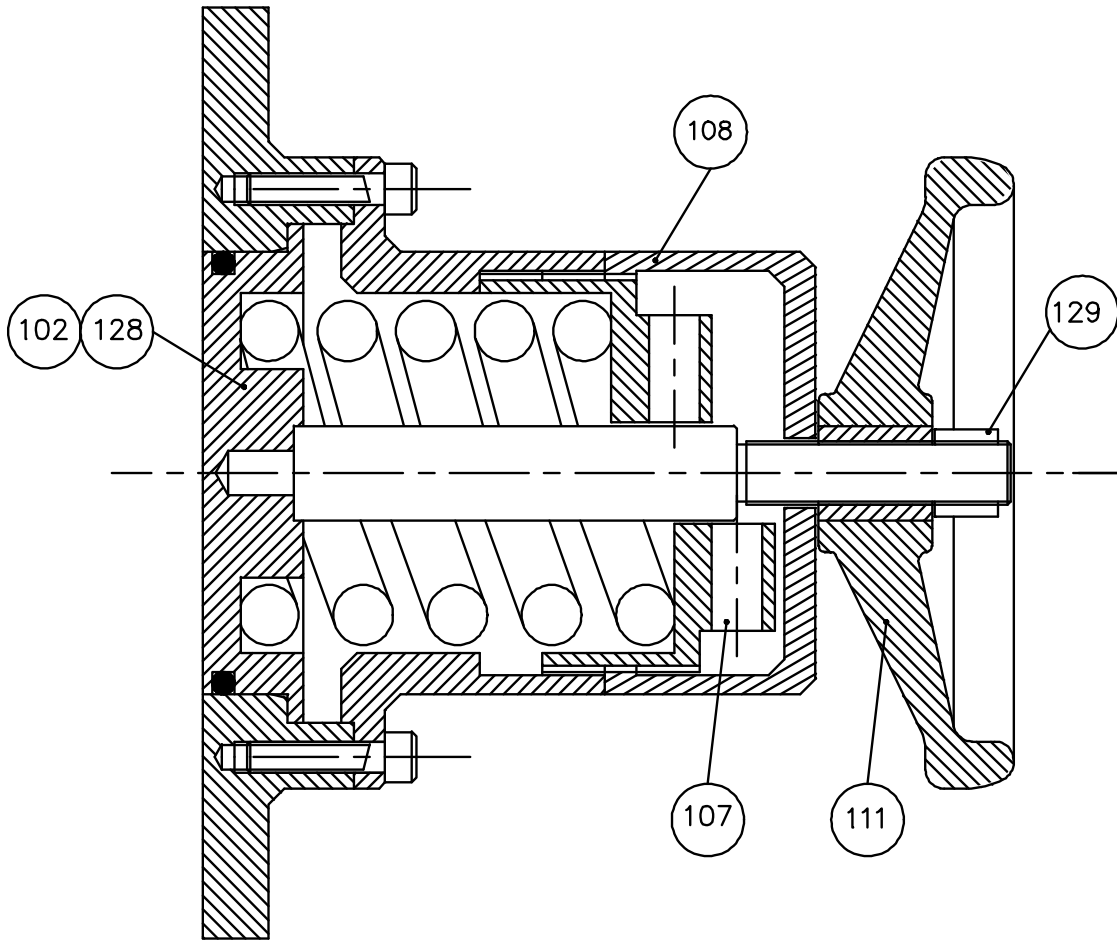


Fig 12.5 Spring Loaded Integral Pressure Relief Valve OL4 (S4) Typical.

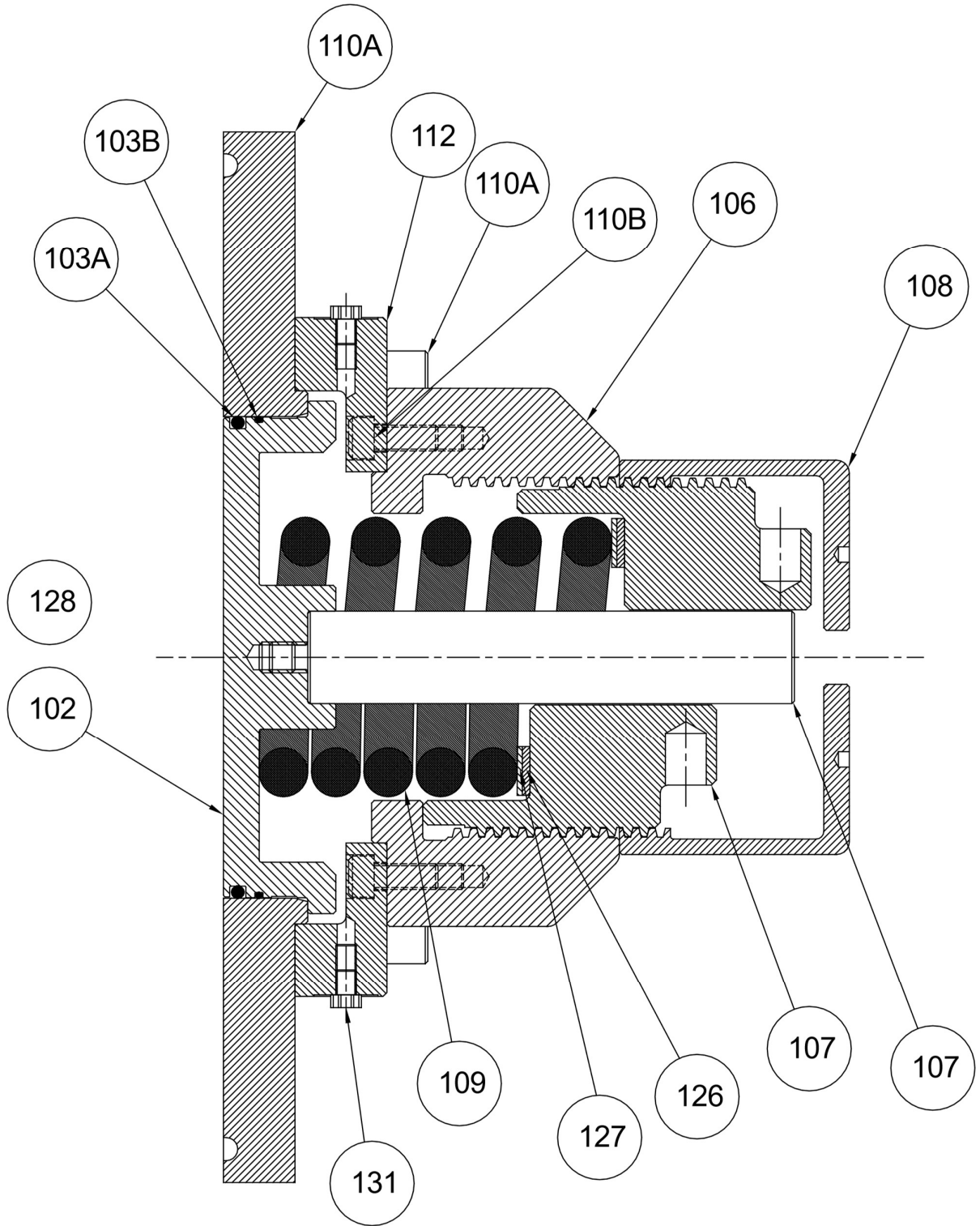


Fig 13

Spring Loaded Integral Pressure Relief Valve with airlift OL1, OL2, OL3 (S1, S2, S3) Typical.

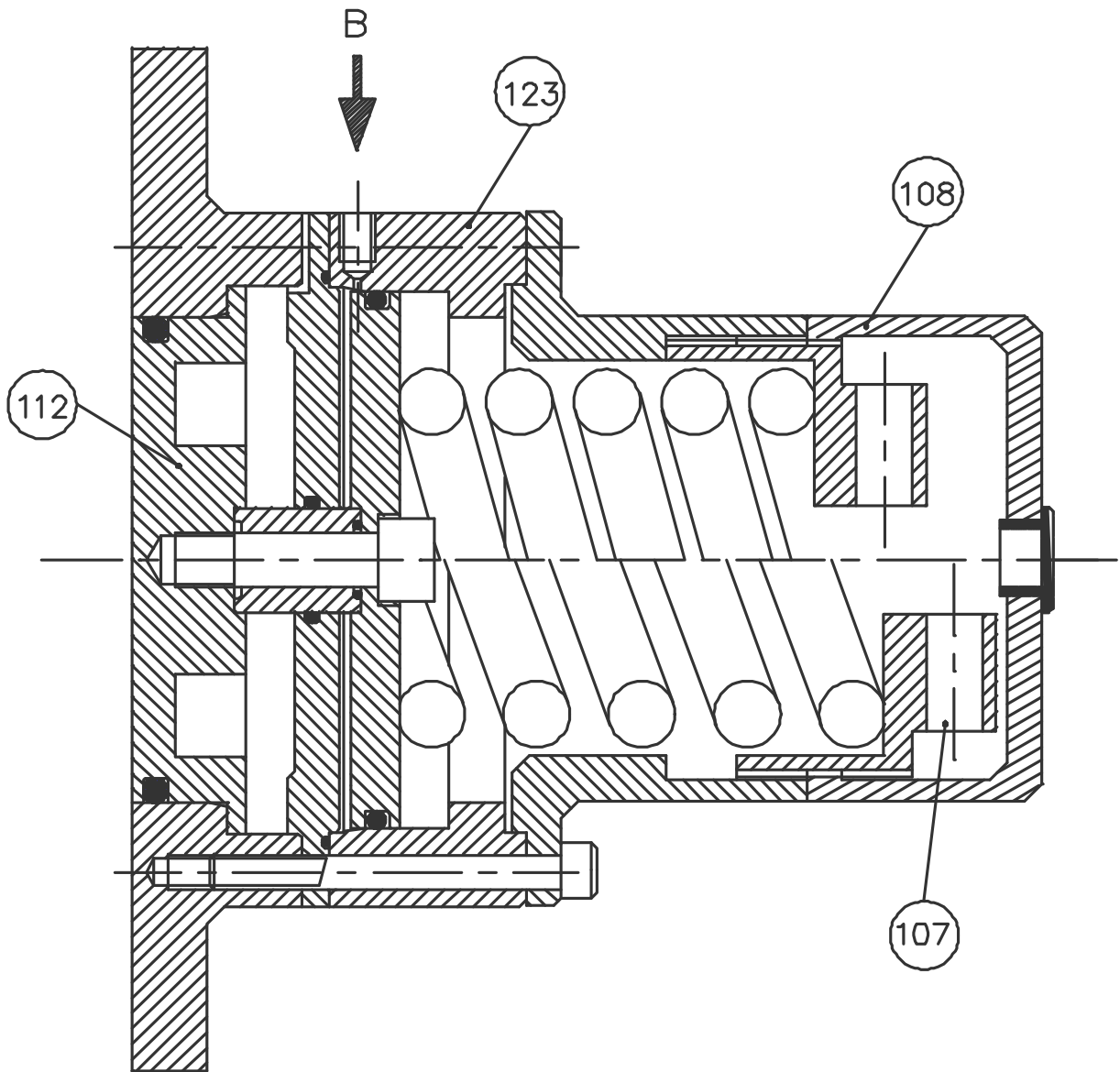


Fig 14 Air Loaded Integral Pressure Relief Valve with airlift OL1, OL2, OL3 (S1, S2, S3) Typical.

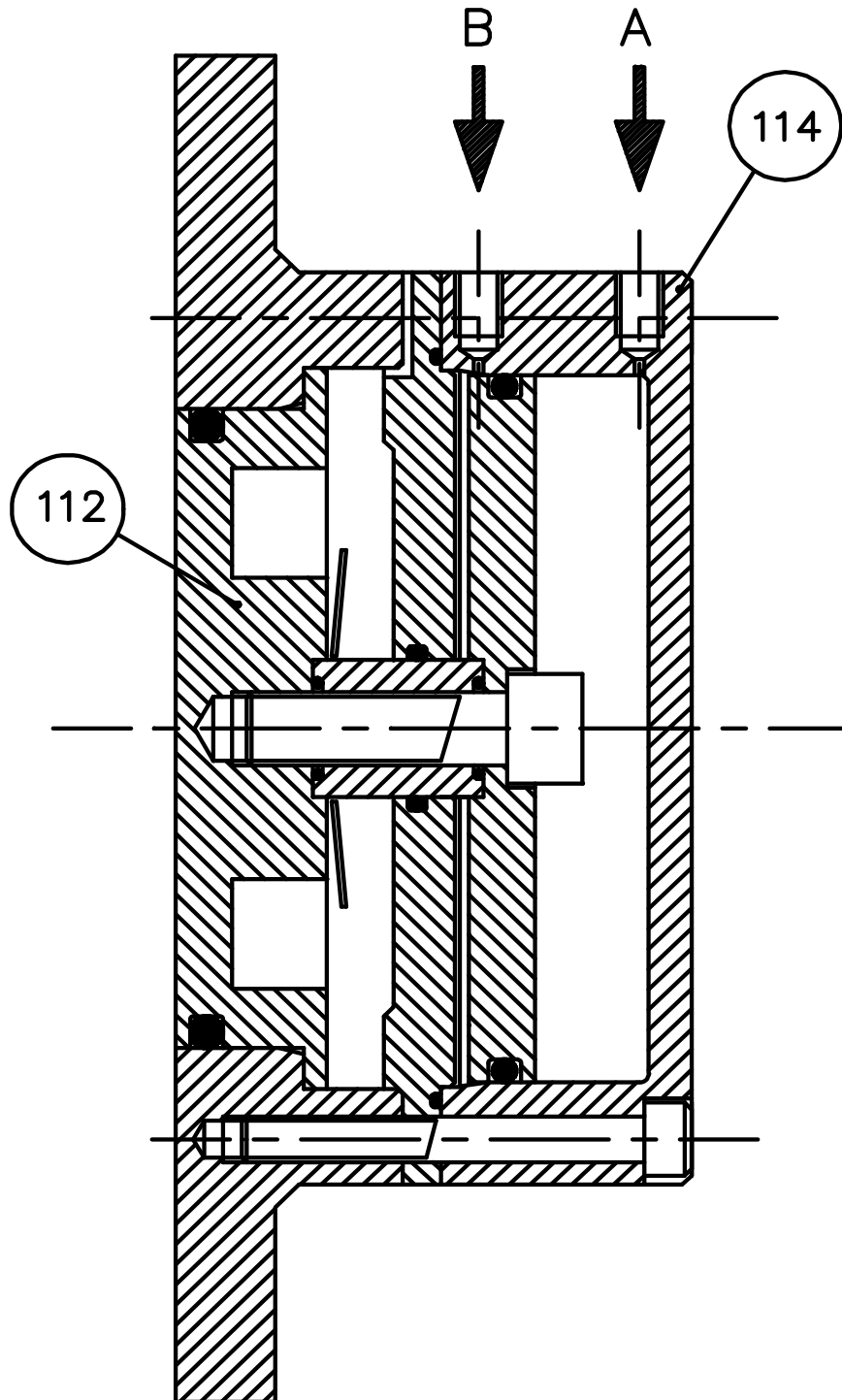
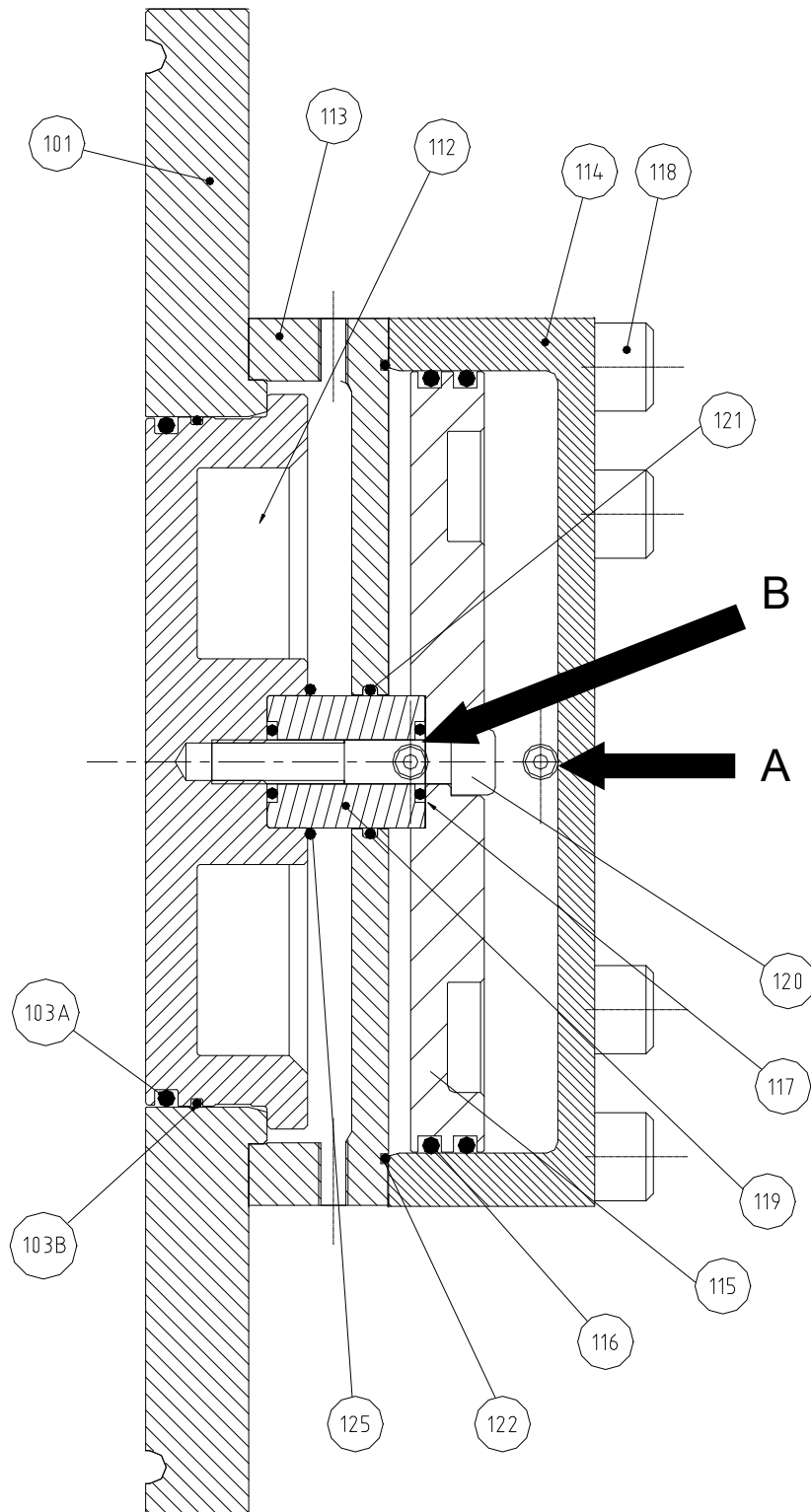


Fig 14 .5 Air Loaded Integral Pressure Relief Valve with airlift OL4 (S4) Typical



4.0 On Line / Duralobe Pump Dismantling and Assembly.



Before undertaking any work on the pump the recommended Shutdown Procedure should be followed, refer to section 3.5, and site safety practices must be observed.



While dismantling or assembling the pump it is essential to ensure that the pump and/or components are secured to provide adequate stability.



Large pump components or sub assemblies should be lifted using suitable devices. Use threaded holes for the attachment of lifting eyes where appropriate.

During dismantling or before assembly all components should be inspected for fit, wear, and damage. If worn or damaged the components should be replaced before re-assembly.

The position of all parts should be identified as they are removed to ensure they are reinstalled in the same position.

Lipseals and o-rings are incorporated within the shaft cartridge assemblies and the gearbox cover to contain the lubricant for the bearings and timing gears. Regular inspection and correct maintenance of these items will ensure that the lubrication is sustained and the pump maximum working life is achieved. To ensure this, it is extremely important that care is taken when removing and installing new o-rings and lipseals. When removing and replacing lipseals ensure that the location bore for the outside diameter and the seat for the back of the lipseal is not damaged as this may create a leak path for the lubricant.

When removing lipseals or o-rings care should be taken to avoid cutting or tearing the sealing faces as they pass over keyways, splines, threads or other potentially sharp or abrasive edges. All lipseals and o-rings should be carefully examined and if damaged in any way, replaced on assembly.

All o-rings and sealing lips of lipseals should be lightly lubricated with a suitable lubricant (silicon grease, etc.) before installing.

When installing lipseals do not allow the rear face to come into contact with bearings.

Prior to beginning assembly, ensure all parts are clean and free from burrs or damage. Where a vice is to be used, it should have protective jaws to avoid damage to components. Do not hammer or apply undue force to install or position components.

WARNING

All fasteners are required to be tightened to the required torque setting during assembly, refer to section 5.2.



The preferred method of installing bearing cones is to heat them to approximately 120°C (250°F) prior to installation. During this operation protective gloves should be used. Once bearing cones are installed in correct position they should be allowed to cool before proceeding with assembly. As an alternative, bearing cones may be pressed into position providing the proper equipment is employed and the necessary procedures are used to prevent component damage.

Under no circumstances should bearing cones or cups be hammered into position.

For torque settings of fasteners and shaft rolling torque, see section 5.2.

4.1 Disassembly.

4.1.1 Front Cover and Rotor Removal see Fig 15.



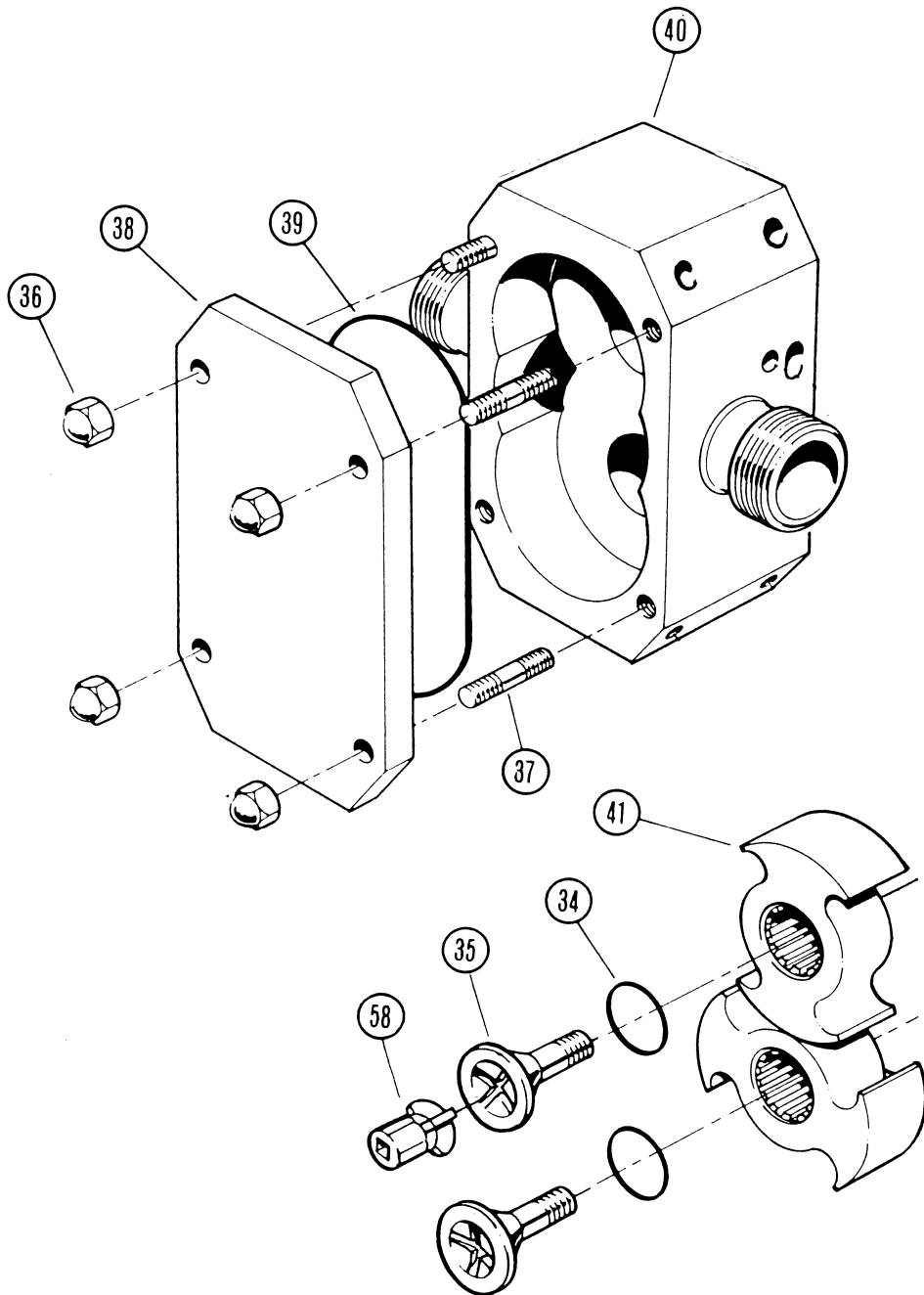
- Follow recommended Shutdown Procedure, refer to section 3.5.
- Gradually loosen front cover retaining dome nuts (36). Care should be taken as there may still be residual product and pressure in the pump head. As the dome nuts are loosened this will vent to atmosphere.
- Remove dome nuts (36).
- Remove front cover (38), using lever slots where necessary and the front cover o-ring (39).
- Remove rotor retainers (35) using socket (58).

Note: The socket (58) should always be used. The use of other tools may damage the retainer.

WARNING

- Remove retainer o-ring (34).
- Remove rotors (41) from shafts (items 9 and 10 see fig 5.6 on page 60), taking care not to damage the product seal components.

Fig 15 Front Cover and Rotor Removal.



4.1.2 Cartridge Removal (after completing 4.1.1) - see Fig 16.

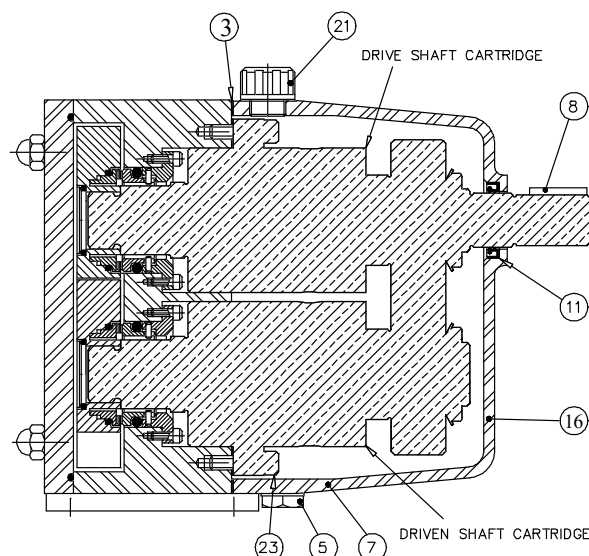
The following procedures assume the pump has been removed from the base plate.

Remove product seals before proceeding with cartridge removal, refer to section 4.3.

- Remove oil drain plug (5) and breather (21). Drain oil into suitable container and retain if later inspection is required.
- Remove drive coupling (not shown).
- Remove drive key (8).
- Remove gearbox cover retaining screws (7).
- Remove gearbox cover (16) and gasket (3).
- Remove lipseal (11) from gearbox cover (16).
- Remove shaft cartridge retaining screws (23).
- Extract shaft cartridge assembly using lever slots if necessary, taking care not to damage the shims (22 – not shown). The shaft cartridge is an assembly of parts 20,19,25,24,17,57,8,14,13,12, 22, 8, and 9 or 10 (items 9 and 10 see fig 5.6 on page 61). Keep shims (22) in sets and identify position.

Note: Shims (22) may be different for each cartridge and therefore should be kept with their respective cartridge.

Fig 16

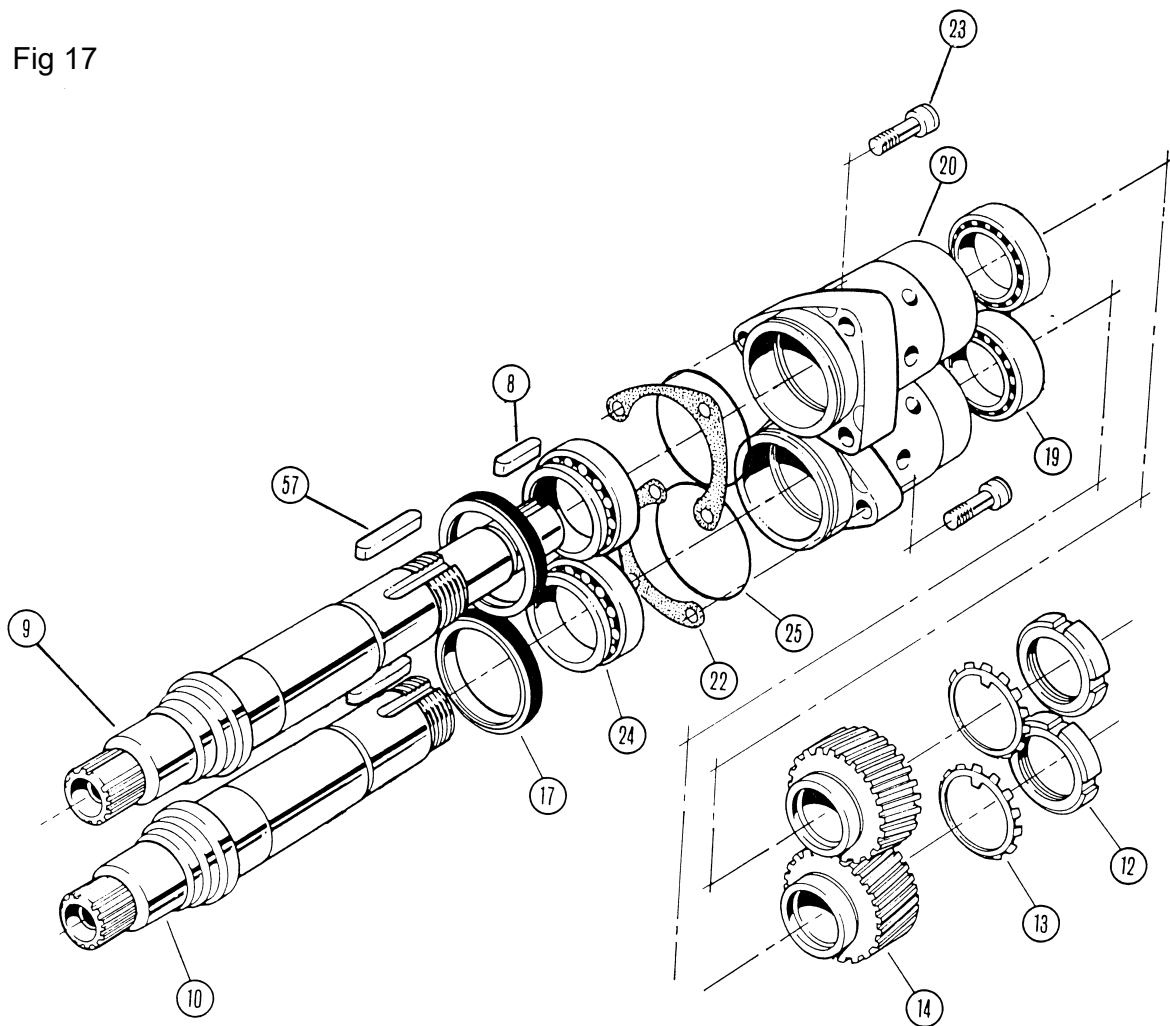


4.1.3 Cartridge Disassembly

See Fig 17.

- Remove locknut (12) and tab washer (13).
- Remove timing gear (14) noting that the drive shaft gear (stamped D) has a right hand helix and the driven shaft gear (stamped L) a left hand helix.
- Remove gear key (57).
- Remove front oil seal (17).
- Remove shaft (9 or 10) from bearing sleeve (20).
- Remove bearing inner cones (24) from shafts (9 and 10).
- Remove bearing cups (24) from bearing sleeves (20).

Fig 17



4.2 Assembly.

4.2.1 Cartridge Assembly

See Figs 18, 19, 20, 21 and 22.

- Install bearing cups (19) and (24) to bearing sleeves (20).

Fig 18

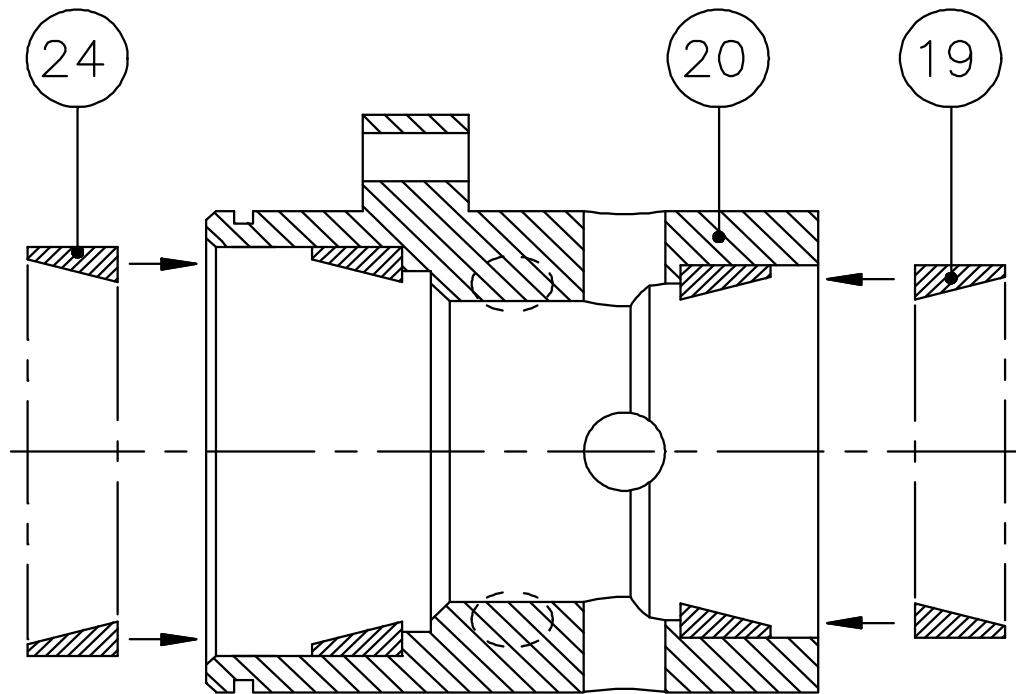


Fig 19

- Heat cones to 120°C (250°F) and install front bearing cones (24) onto shafts (items 9 and 10 see fig 5.6 on page 60).

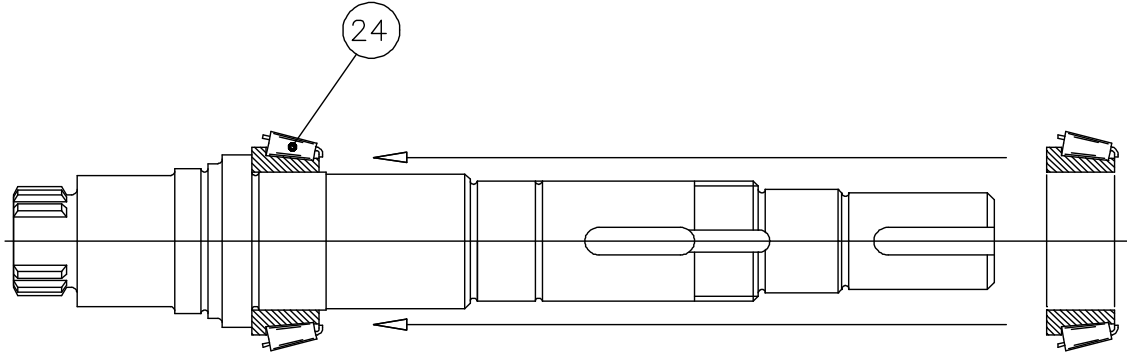


Fig 20

- Install bearing sleeves (20) to shafts (items 9 and 10 see fig 5.6 on page 60) with securing lugs towards the spline end of the shaft so that the bearing cup locates with the cone (24).

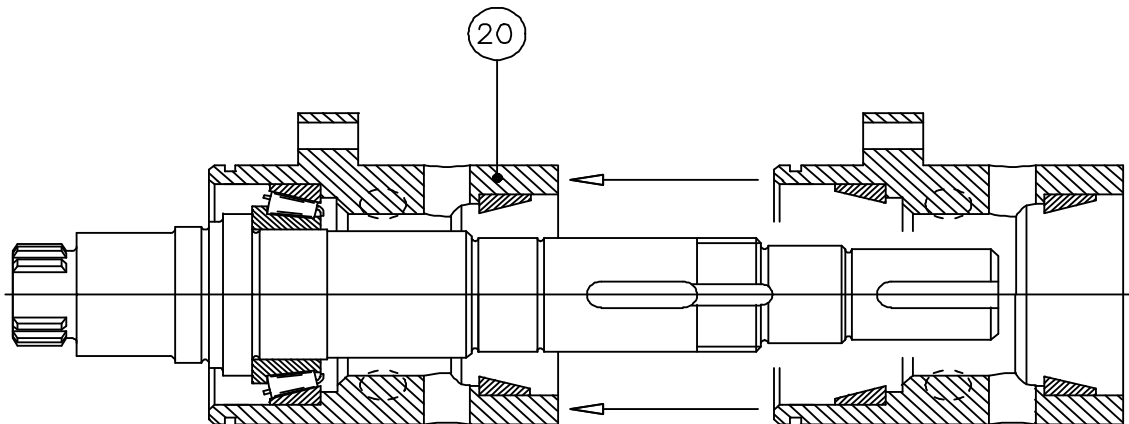
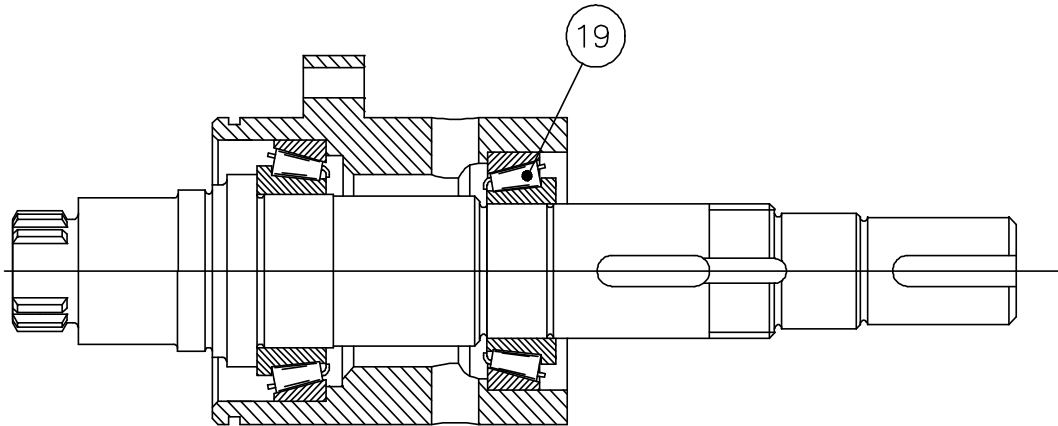


Fig 21



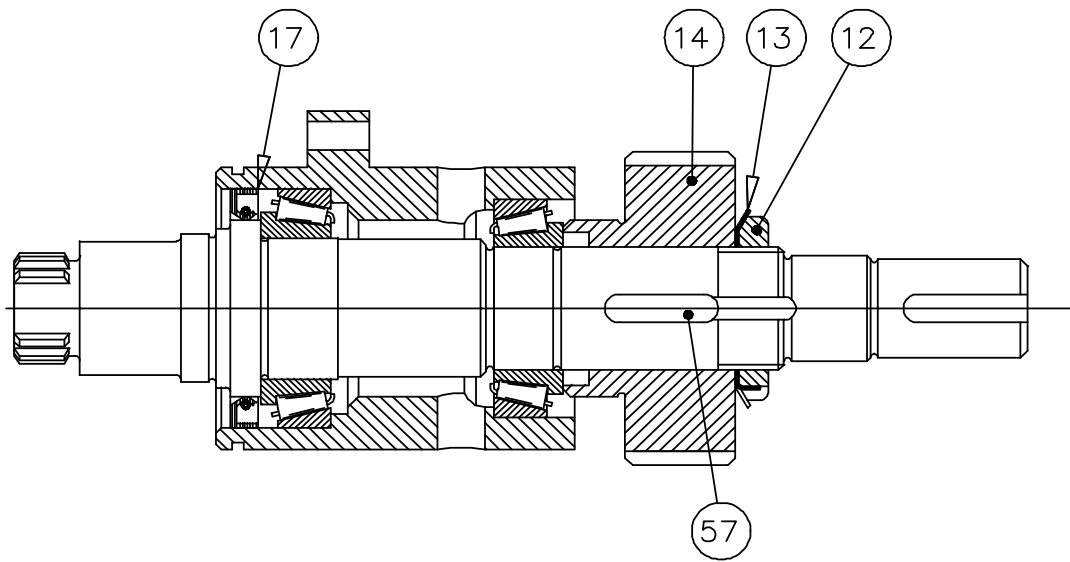
- Heat cones to 120°C (250°F) and install rear bearing cones (19) to shafts (items 9 and 10 see fig 5.6 on page 60). Do not use excessive pressure as rolling torque is achieved by adjusting rear lock nuts (12).
- Install gear keys (57) and gears (14) into position insuring that the gear boss contacts with the rear bearing cone (19).

Note: Right hand helix for drive shaft gear (stamped D), left hand helix for driven shaft gear (stamped L).

Note: When ordering spare timing gears it is essential to purchase and install these as a pair.

- Install tab washers (13) and lock nuts (12). Do not secure tab washers (13).
- Tighten lock nuts (12) and adjust to achieve correct rolling torque, refer to section 5.2. To measure the rolling torque, place assembled cartridge, with the splined end of the shaft uppermost, into a vice gripping on the bearing sleeve. **Do not over tighten the vice as the sleeve is a precision component and should not be distorted.** Screw a bolt into the tapped hole in the splined end of the shaft. Rotate the shaft by means of the bolt using a torque meter. If the rolling torque does not correspond to the required setting, adjust lock nuts (12).
- Secure tab washer (13) after setting correct rolling torque.
- Install lipseals (17) to bearing sleeves (20).

Fig 22

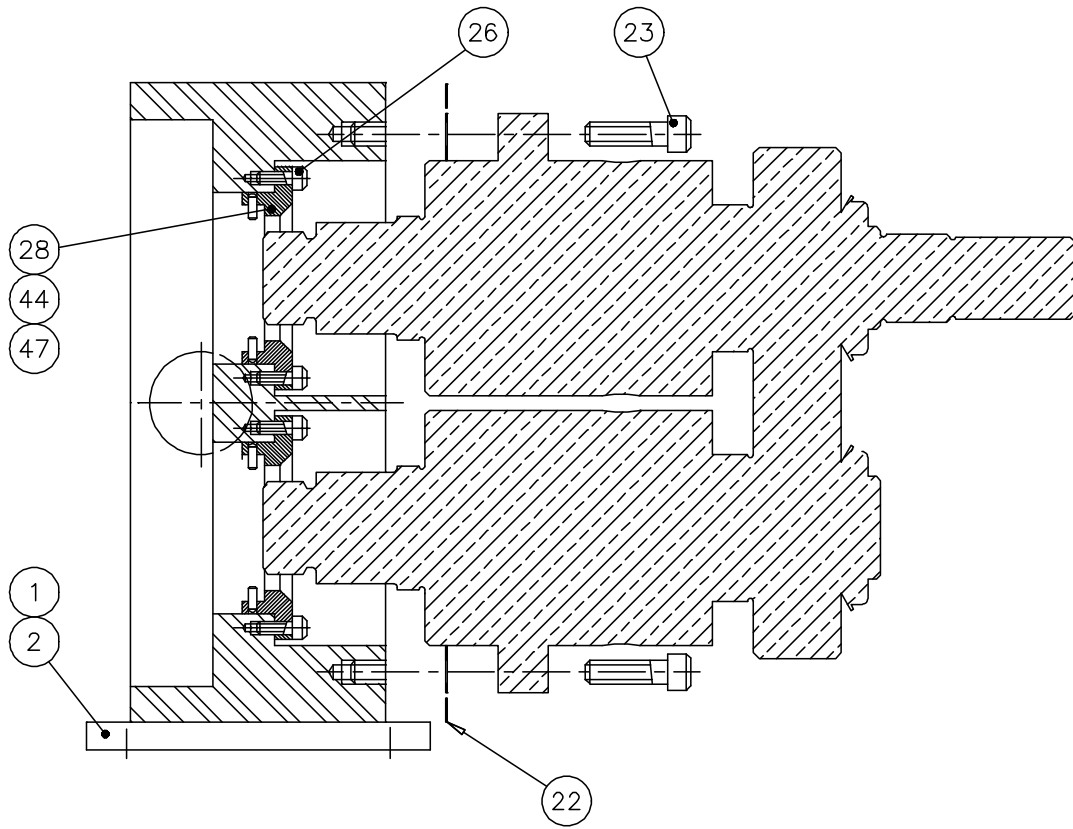


4.2.2 Cartridge to Rotorcase Assembly

See Fig 23.

- If not already installed, mount feet (1) to rotorcase (item 40 see fig 5.6) in the required positions using cap head screws (2). Install the relevant product seal housing (28, 44, 47 or 156) with associated gasket or o-ring or lipseal (single flushed and double flushed mechanical seals only) and wave spring (single mechanical seal only) to the rear of the rotorcase (40) and secure with screws (26).
- Install o-rings (25) to front diameter of bearing sleeves (20).
- Assemble cartridges into rotorcase (40) rear bores insuring that timing marks on the timing gears (14) are in mesh (single dot on drive shaft gear, two dots on driven shaft gear). The timing gears are in correct mesh when the single dot on the drive shaft gear is between the two dots on the driven shaft gear. Leave a small gap between rear face of rotorcase (40) and cartridge mounting face for inserting shims (22).
- Insert shims (22) between rotorcase (40) and cartridge. Shims can be plastic or steel and are either marked with their thickness or are colour coded as follows :
 - Blue = 0.050mm thick (0.002")
 - Green = 0.075mm thick (0.003")
 - Clear = 0.150mm thick (0.006")
 - White = 0.250mm thick (0.010")Note always check with a micrometer or similar device
- Secure cartridges to rotorcase (40) with cap head screws (23), tightening to correct torque, refer to section 5.2.
- Install rotors (41), refer to section 4.2.3.
- Using a depth micrometer or similar device measure "actual" rotor front clearance. This is the clearance between the front face of the rotorcase and the front face of the rotor. Select "required" front clearance (A) from the Clearance Chart, refer to section 5.1. The difference between the "actual" measured clearance and the "required" clearance, as given on the Clearance Chart, is the amount of shim (22) that needs to be removed or added.
- Having determined the amount of shim (22) to be removed or added, remove rotors (41), refer to section 4.1.1. Remove cap head screws (23). Taking care not to damage the shims (22), ease cartridge from rotorcase (40) using lever slots to create a gap to access the shims (22). Remove or add appropriate amount of shim between rotorcase (40) and shaft cartridge flange.
- Secure cartridges to rotorcase (40) with cap head screws (23) tightening to correct torque refer to section 5.2.

Fig 23



4.2.3 Rotor Assembly and Setting Rotor Clearances see Fig 24.

- Do not install product seals at this point.
- Install rotors (41) onto shafts (9 and 10) in rotorcase (40), install retainer o-ring (34) into bore in rotor and secure with rotor retainer (35) set to the correct torque (see section 5.2) using socket (58).

Note: The retainer o-ring (34) seals the shaft/rotor spline and should not be re-used if cut, distorted or damaged in such a way as to impair its ability to form a seal. If in doubt a new o-ring should always be installed.

- Using a depth micrometer or similar device measure front clearance (A) between the rotorcase and rotor front faces and check that this corresponds to the appropriate clearance as indicated on the Clearance Chart, refer to section 5.1.
- If the front clearance (A) is incorrect adjustment of the shims (22) between the rotorcase and cartridge is required, refer to section 4.2.2 Cartridge to Rotorcase Assembly.
- With rotors (41) installed, check all clearances, front (A), radial (C), rear (B) and mesh (D), against the Clearance Chart, refer to section 5.1. Remove rotors (41) and install product seals, refer to section 4.3 Product Seal Fitting and Removal, and reassemble rotors (41) tightening to the correct torque.

WARNING

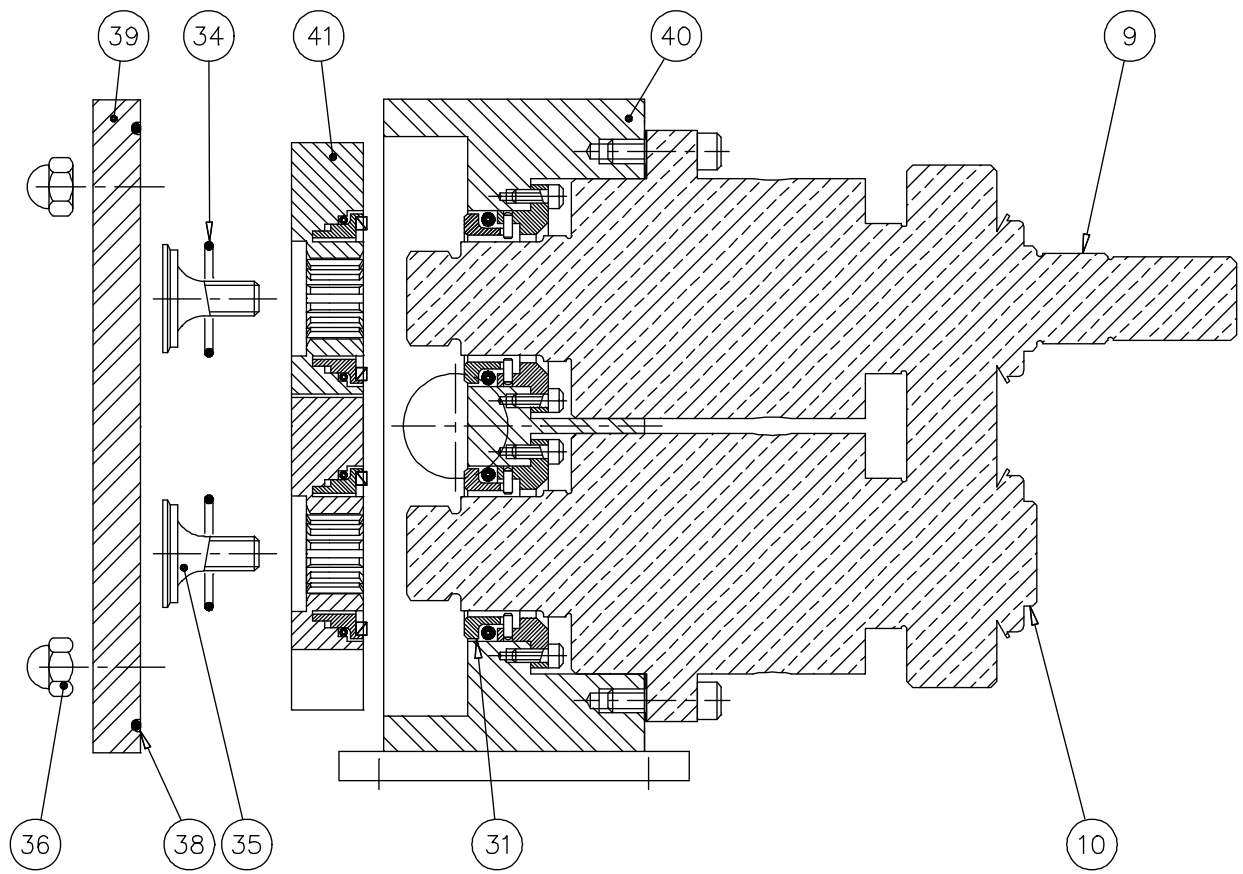
Note: When fitting mechanical seals be sure that the seal stationary seat (31) is properly engaged with the seal housing (28) drive pin or serious damage to the pump will result.

- Install o-ring (38) to front cover (39).
- Install front cover (39) to rotorcase (40), securing with dome nuts (36), tightening to correct torque, refer to section 5.2.

WARNING

Note: It is recommended that rotors should be installed in pairs, although parts are available individually.

Fig 24



4.2.4 Gearbox Cover Assembly
see Fig 25.

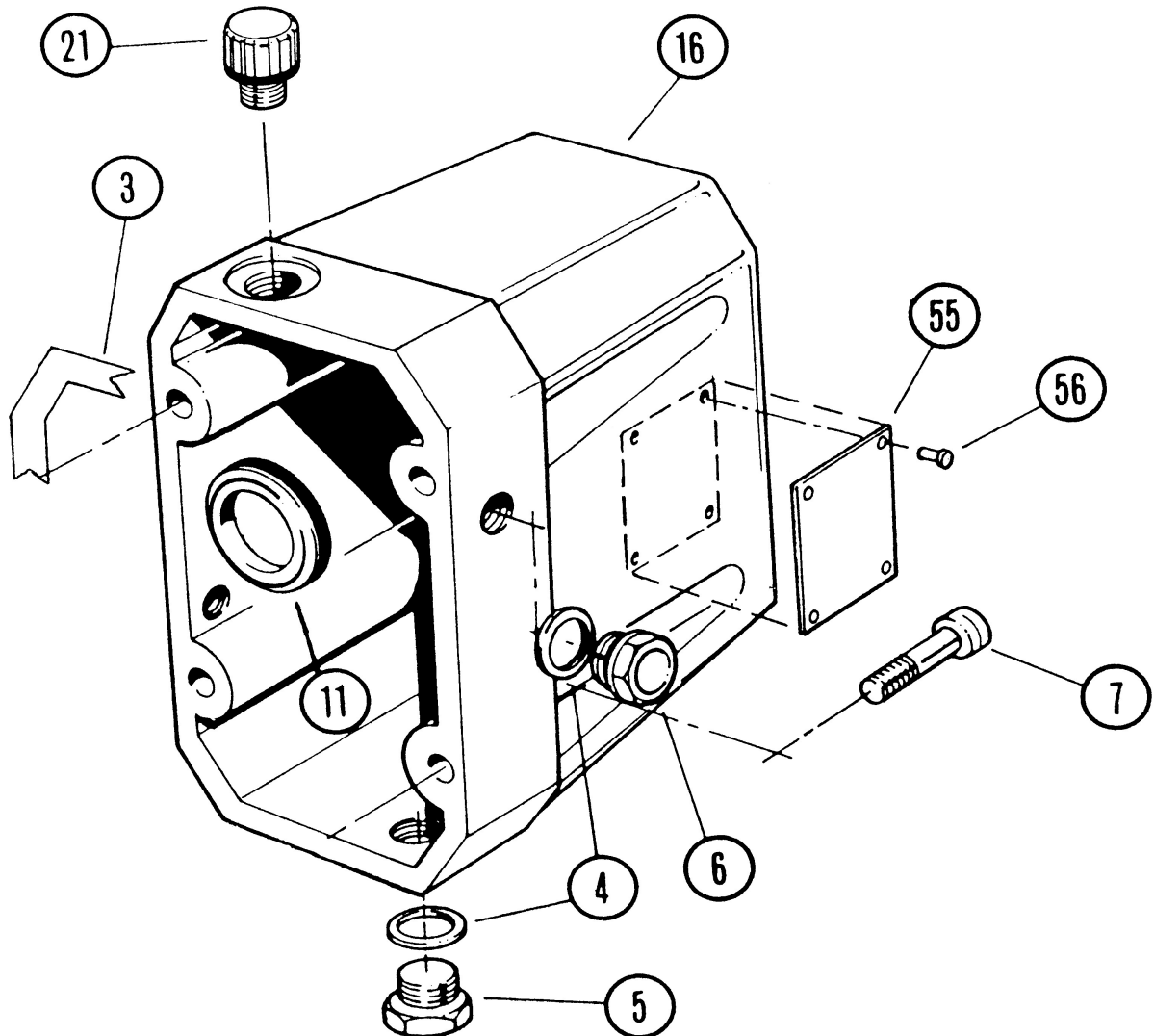
- Install lipseal (11) to gearbox cover (16).
- Install breather (21); drain plug (5) and sight glass (6) in required position in gearbox cover (16).

WARNING

Note: The sight glass (6) must be installed in the upper tapped hole in the side of the gearbox cover (16). Remember to fill the gearbox with oil prior to start up. For recommended lubricant capacities and grades refer to section 5.3.

- Install gearbox cover (16) with gasket (3) to rotorcase (40) securing with screws (7), tightening to the correct torque, refer to section 5.2.

Fig 25



4.3 Product Seal Fitting and Removal.

4.3.1 General Procedures for Fitting Mechanical Seals.

"Quick summary" of mechanical seal installation.

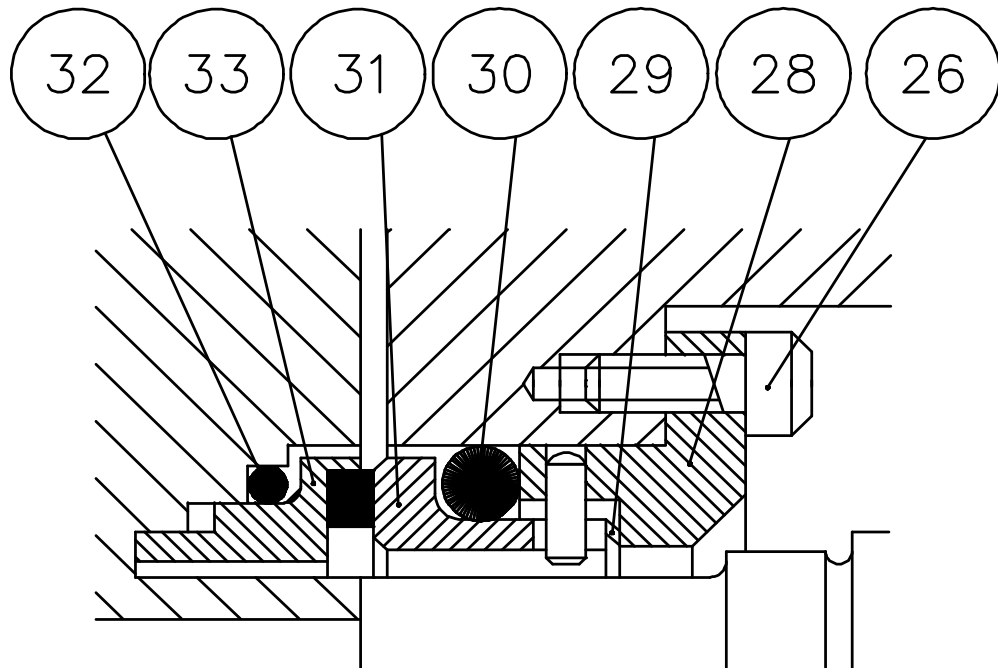
- Mechanical seals are precision-engineered assemblies incorporating finely lapped seal faces and seats. They must therefore be handled with care and will not give optimum performance unless installed carefully and according to instructions.
- Where mechanical seals are to be reused ensure that seal components are kept in their appropriate sets. **Do not mix old and new seal faces on the same seal.**
- Remove any sharp corners and burrs that may damage any elastomers such as o-rings or lip seals.
- Ensure that all seal component fitting bores and housings are thoroughly cleaned before installation.
- The seal faces and seats must be handled with care and cleaned thoroughly before installation.
- Ensure that seal faces are undamaged and the o-rings are not cut, swollen, or cracked.
- All o-rings should be lightly lubricated with a suitable lubricant (silicon grease, soap etc.) before fitting but ensure there is no excessive amount of lubricant especially around the seal face area.
- When fitting PTFE encapsulated o-rings it is important to immerse them in hot water for several minutes to soften them.
- Ensure seal seats are mounted squarely in the rotorcase.
- Ensure when installing seals with brittle faces such as silicon carbide that extra care is taken.
- Do not use any excessive force to install a mechanical seal. If it is difficult to position and assemble the seal then something is wrong.
- If you drop or damage a seal, do not install it before an inspection has been carried out.
- Do not run a mechanical seal dry.

WARNIN

4.3.2 Single Mechanical Seal

See Fig 26.

Fig 26



Read the General Procedures to prepare for seal installation refer to section 4.3.1 before assembly Ensure that all seal components are clean and grease free.

- Install wave springs (29) to housings (28).
- During Pump assembly install housings (28) to rotorcase securing with screws (26) tightening to correct torque, refer to section 5.2. If only the seal faces are being replaced, the housings (28) and wave springs (29) will already be in place.
- Install o-rings (32) to rotors (item 41 see fig 5.6 on page 60).
- Install rotary seal faces (33) into rotors (item 41 see fig 5.6) ensuring that the drive lugs and drive slots engage. Make sure the o-rings (32) are located correctly and that the seal faces (33) are sitting squarely in the rotors (item 41 see fig 5.6).
- Install o-ring (30) to stationary seat (31).
- Gently push the stationary seat and o-ring (30,31) assemblies into the seal housings (28), ensuring drive pins and slots are engaged.
- You should now be able to feel the resistance being generated by the wave spring (29).

Removal of Single Mechanical Seals.



- Ensure pump is fully shutdown, refer to section 3.5.
- To remove single mechanical seals, reverse the above procedure using the extraction tool (61) to aid in the removal of the seal faces, see fig 27.

WARNING

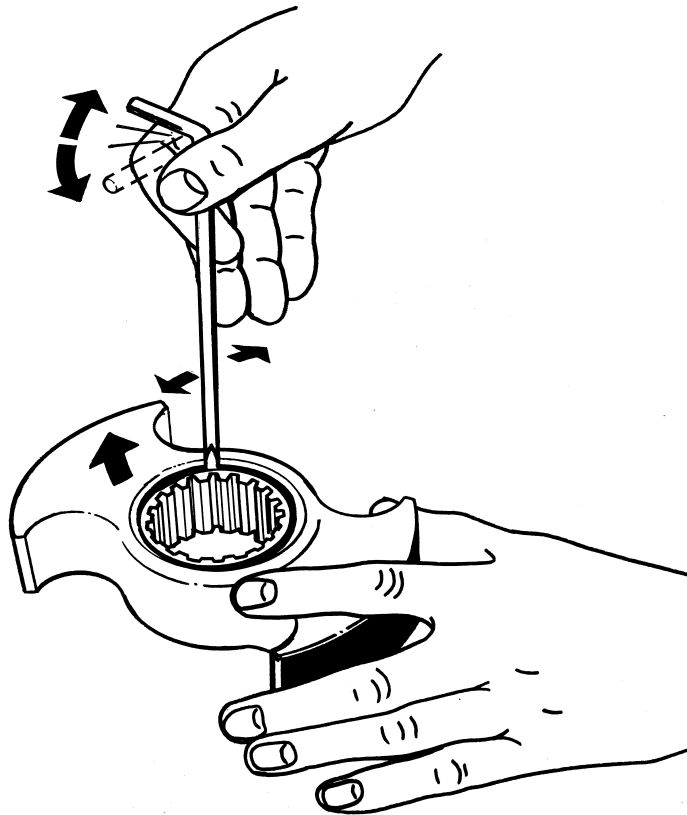
Note: If seals are being reused, ensure that seal faces remain matched.

- With reference to fig 26 remove rotary seal faces (33) from rotors (41) using the extraction tool (61). This is achieved by inserting the extraction tool between the rotary seal face (33) and the rotor (41) applying a twisting action, see fig 27. It may be necessary to alternate from side to side in order to facilitate removal.
- The static seal face (31) can be removed by using the same technique.

WARNING

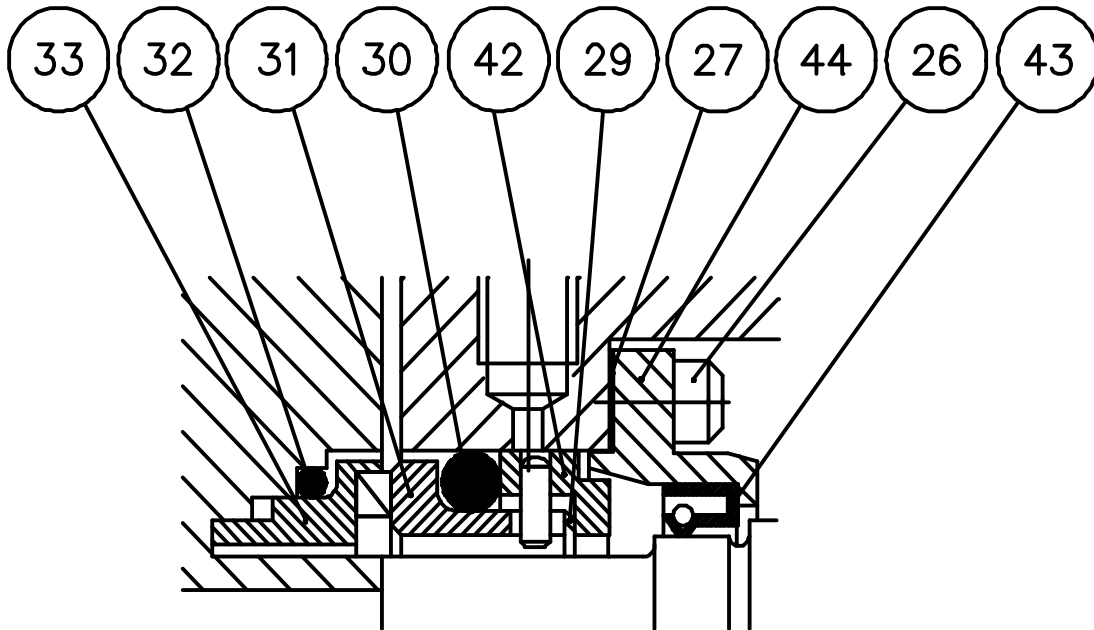
Note: Extreme care should be taken when carrying out these procedures to ensure that the seal faces are not damaged. No excessive force is necessary if the extraction tool is used correctly.

Fig 27 Use of Seal Face Extraction Tool.



4.3.3 Single Flushed Mechanical Seal
(for low-pressure flush/quench) - see Fig 28.

Fig 28



Read the General Procedures to prepare for seal installation, refer to section 4.3.1.

- Install lipseal (43) to flushed housing (44).
- During Pump assembly Install housing (44) to rotorcase securing with screws (26) tightening to correct torque, refer to section 5.2. Ensure the gasket or o-ring (27) is in place before tightening screws (26).
- Locate thrust ring (42) into rotorcase (item 40 see fig 5.6) to engage with flushed housing (44). Ensure wave spring (29) is installed to thrust ring (42). If only the seal faces are being replaced the housing (44) and thrust ring (42) will already be in place.
- Install o-rings (32) into rotors (item 41 see fig 5.6).
- Install rotary seal faces (33) into rotors (item 41 see fig 5.6) ensuring that the drive lugs and drive slots engage. Make sure the o-rings (32) are located correctly and that the seal faces (33) are sitting squarely in the rotors (item 41 see fig 5.6).
- Install o-rings (30) to stationary seats (31).

- Gently push the stationary seat and o-ring assemblies (30 and 31) into the thrust rings (42), ensuring drive pins and slots are engaged.
- You should now be able to feel the resistance being generated by the wave springs (29).
- Before final assembly, check that the seal faces are absolutely clean, use a soft tissue and a suitable solvent based cleaner for best results.

Disassembly of Single Flushed Mechanical Seals.



Ensure pump is fully shutdown, refer to section 3.5.

To disassemble, reverse the above procedure using the extraction tool supplied to aid in the removal of the seal faces, see fig 27.

- Remove rotary seal faces (33) from the rotors (41 see fig 5.6) using the extraction tool (61). This is achieved by inserting the extraction tool between the rotary seal face (33) and the rotor (41) and applying a twisting action, see fig 27. It may be necessary to alternate from side to side to facilitate removal.
- The static seal face (31) can be removed by using the same technique.

WARNING

Note: Extreme care should be taken when carrying out these procedures to ensure that the seal faces are not damaged. No excessive force is necessary if the extraction tool is used correctly.

Disassembly of Double Mechanical Seals.



Ensure pump is fully shutdown, refer to section 3.5.

To disassemble, reverse the above procedure using the extraction tool supplied to aid in the removal of the seal faces, see Figs 27 and 30.

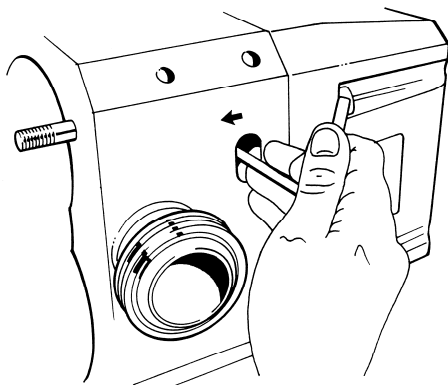
Note: If seals are being reused, Ensure that seal faces remain matched.

- Remove rotary seal faces (33) from rotors (41) using extraction tool (61). This is achieved by inserting the extraction tool between the rotary seal face (33) and the rotor (41) and applying a twisting action, see Fig 27. It may be necessary to alternate from side to side to facilitate removal.
- Remove stationary seal cartridge assemblies (29,48 and 51) from the shafts (9 and 10) by pulling off.
- Remove rotary seal face (46). This can be achieved by inserting the extraction tool (61) through the drain/leakage detection holes in the sides of rotorcase (40) and applying a twisting action, see fig 30. Note that this procedure can not be applied to certain models of pumps installed with flanged port connections. In this case, access to the rotary seal faces (46) can be gained via the drilled holes in the top and bottom faces of the rotorcase (40).

WARNING

Note: Extreme care should be taken when carrying out these procedures to Ensure that the seal faces are not damaged. No excessive force is necessary if the extraction tool is used correctly.

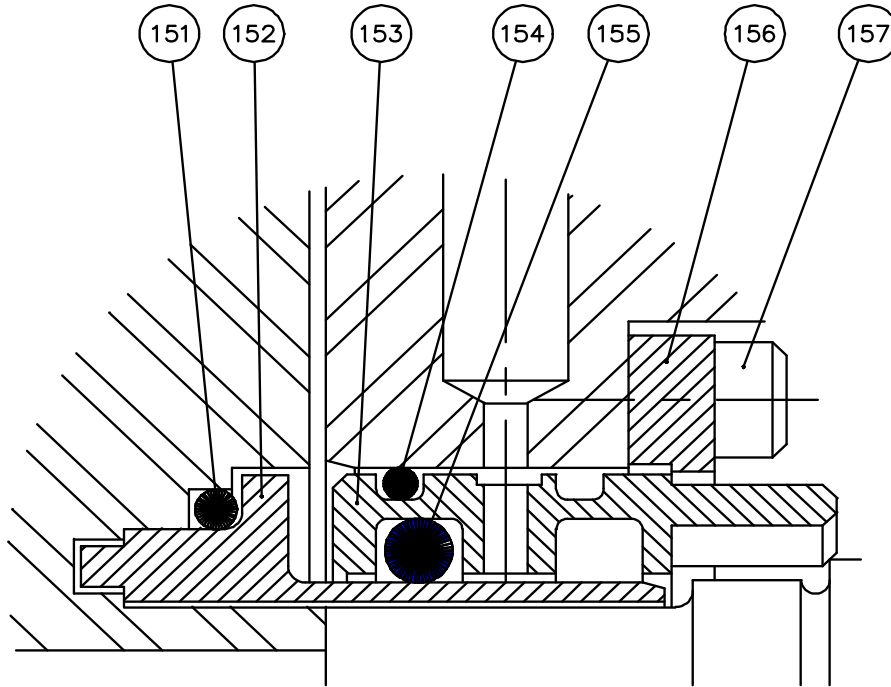
Fig 30 Use of Extraction Tool for the removal of Seal Faces.



Insert seal extraction tool into the drain/leakage detection slots at the side of the rotorcase and apply a twisting action to remove the seal face (item 46 see fig 29 page 47).

4.3.5 Single O-ring Seal Refer to Fig 31.

Fig 31



- During Pump assembly Install seal housings (156) to rotorcase securing with screws (157).
- Install o-rings (155) inside bores of seal sleeve (153) using front groove.

WARNING

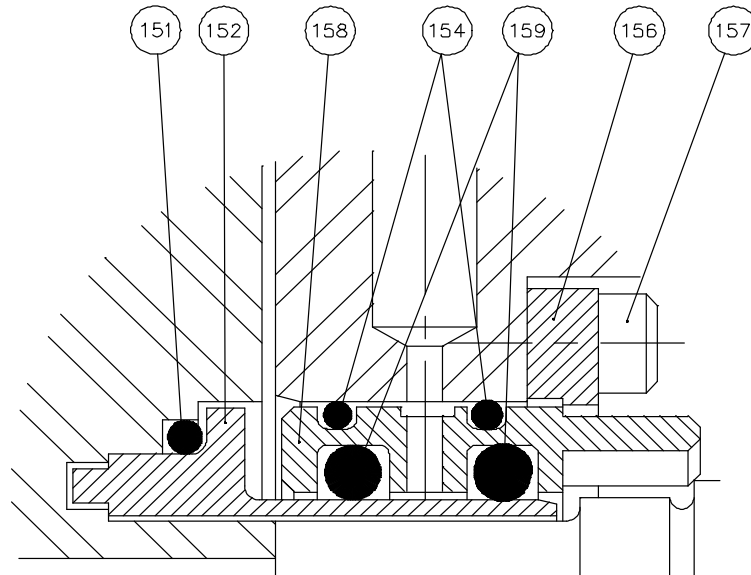
Note: Do not lubricate o-rings (155).

- Install o-rings (154) on outside of seal sleeve (153) using front groove.
- Install seal sleeve assemblies (153,154,155) into rotorcase (item 40 see fig 5.6 on page 60) ensuring drive lugs locate with seal housings (156) correctly.
- Install o-rings (151) into backs of rotors (41 see fig 5.6).
- Install seal sleeve (152) into rotors ensuring drive lugs locate with slots in rotors.
- Install rotor assemblies to shafts refer to section 4.2.3. Care must be taken when entering seal sleeve (152) into o-rings (155).
- To disassemble reverse the above procedure.
- Before disassembling the seals, ensure pump is fully shutdown, refer to section 3.5.



4.3.6 Double O-ring Seal Refer to Fig 32.

Fig 32



- During Pump assembly Install seal housings (156) to rotorcase securing with screws (157).
- Install o-rings (159) into grooves within the inside bore of seal sleeve (158).

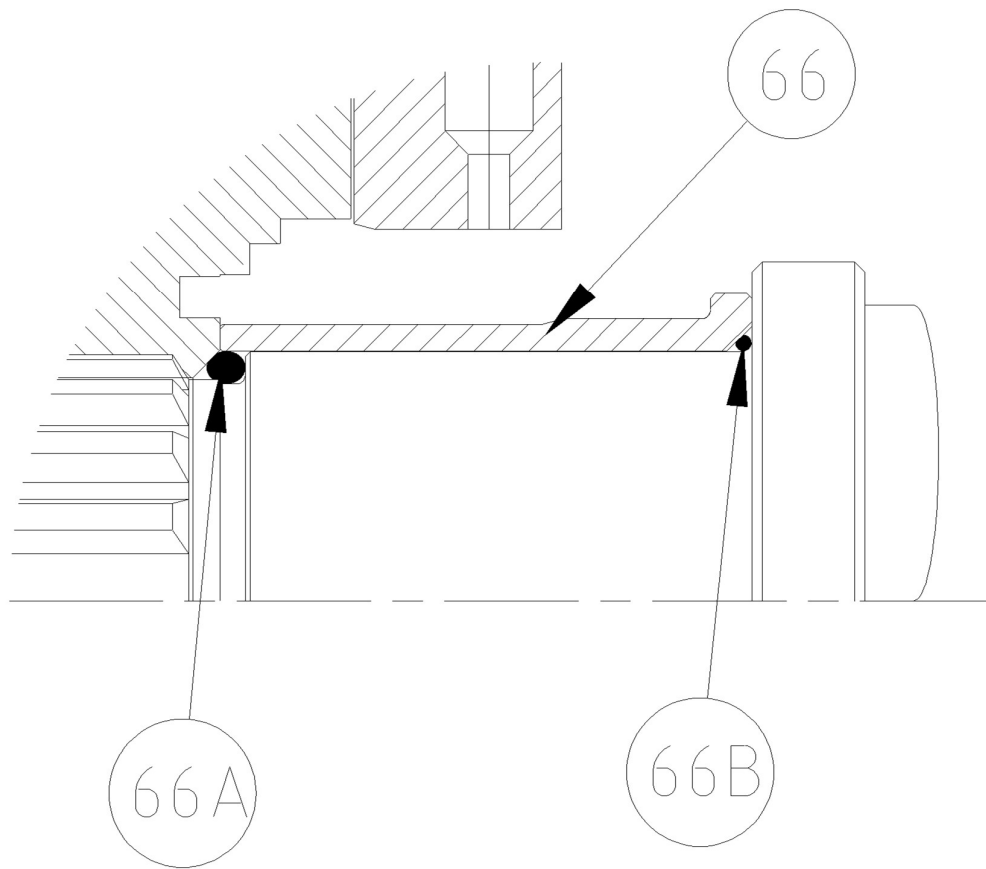
WARNING

Note: Do not lubricate o-rings (159).

- Install o-rings (154) into grooves on the outside of seal sleeve (158).
- Install seal sleeve assemblies (158,159,154) into rotorcase (item 40 see fig 5.6 on page 60) ensure drive lugs locate with seal housings (156) correctly.
- Install o-rings (151) into the back of rotors (item 41 see fig 5.6 on page 60).
- Install seal sleeve (152) into rotors (item 41 see fig 5.6 on page 60) ensuring drive lugs locate with rotor slots correctly.
- Install rotor assemblies to shafts (items 9 and 10 see fig 5.6 on page 60), refer to section 4.2.3. Care must be taken when entering seal sleeve (152) into o-rings (159).
- To disassemble reverse the above procedure.
- Before disassembling the seals, ensure pump is fully shutdown, refer to section 3.5.

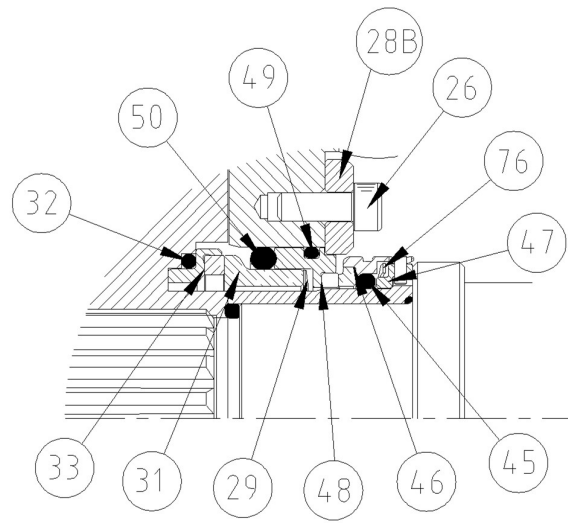


4.3.7 Trapped Sleeve
Fig 34



- Install the o-ring (66B) onto the shaft
- Install the trapped sleeve (66) onto the shaft
- Install the o-ring (66A) onto the shaft

4.3.8 Hybrid Double Mechanical 2000 Seal Fig 35

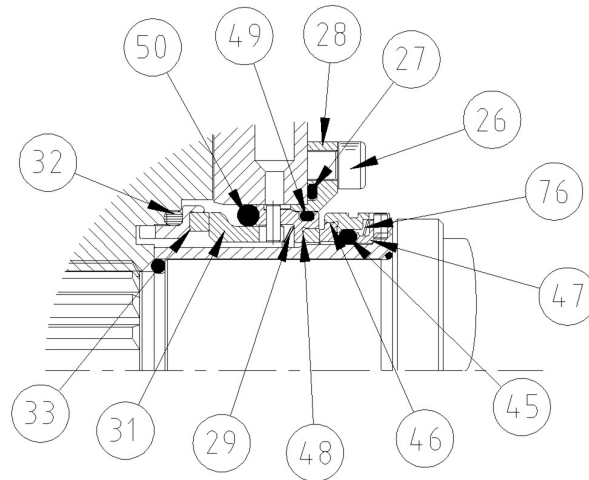


- During Pump assembly fit the anti rotation washers (28B) to the rotorcase securing with screws (26) tightening to correct torque, refer to section 5.2.
- Install the outboard o-ring (45) into the seal face (46).
- Before final assembly check that the seal faces are absolutely clean, use a soft tissue and a suitable solvent based cleaner for best results.
- Install seal cartridge assembly (comprising parts 45, 46, 47, 76) onto the shaft ensuring that the drive lugs and the drive slots engage.
- Install o-ring (49) into the seal seat (48).
- Install seal cartridge assembly (comprising parts 49, 48) into rotorcase, ensure anti-rotation lugs and the anti-rotation washers (28B) engage.
- Install o-ring (50) to the static seal seat (31).
- Install the seal seat assembly (comprising parts 30, 31) into the rotorcase, ensuring that the drive lugs and the drive slots engage.
- Install o-ring (32) onto the rotary seal face (33).
- Install the seal assembly (comprising parts 32, 33) onto the rotor.
- To disassemble reverse the above procedure.
- Before disassembling the seals, ensure pump is fully shutdown, refer to section 3.5.



4.3.09 Hybrid Double Mechanical Seal

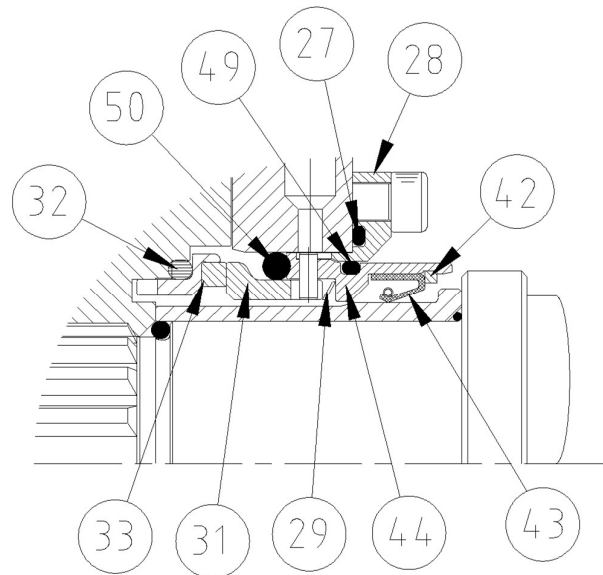
Fig 36



- During Pump assembly fit the seal housing (28) to the rotorcase securing with screws (26) tightening to correct torque, refer to section 5.2. Ensure the gasket or o-ring (27) are in place before tightening screws (26)
- Install the outboard o-ring (45) into the seal face (46).
- Before final assembly check that the seal faces are absolutely clean, use a soft tissue and a suitable solvent based cleaner for best results.
- Install seal cartridge assembly (comprising parts 45, 46, 47, 76) onto the shaft ensuring that the drive lugs and the drive slots engage.
- Install o-ring (49) onto the seal seat (48).
- Install seal cartridge assembly (comprising parts 49, 48) into rotorcase, ensure anti-rotation lugs and the anti-rotation washers (28B) engage.
- Install o-ring (50) onto the static seal seat (31).
- Install the seal seat assembly (comprising parts 30, 31) into the rotorcase, ensuring that the drive lugs and the drive slots engage.
- Install o-ring (32) onto the rotary seal face (33).
- Install the seal assembly (comprising parts 32, 33) into the rotor.
- To disassemble reverse the above procedure.
- Before disassembling the seals, ensure pump is fully shutdown, refer to section 3.5.



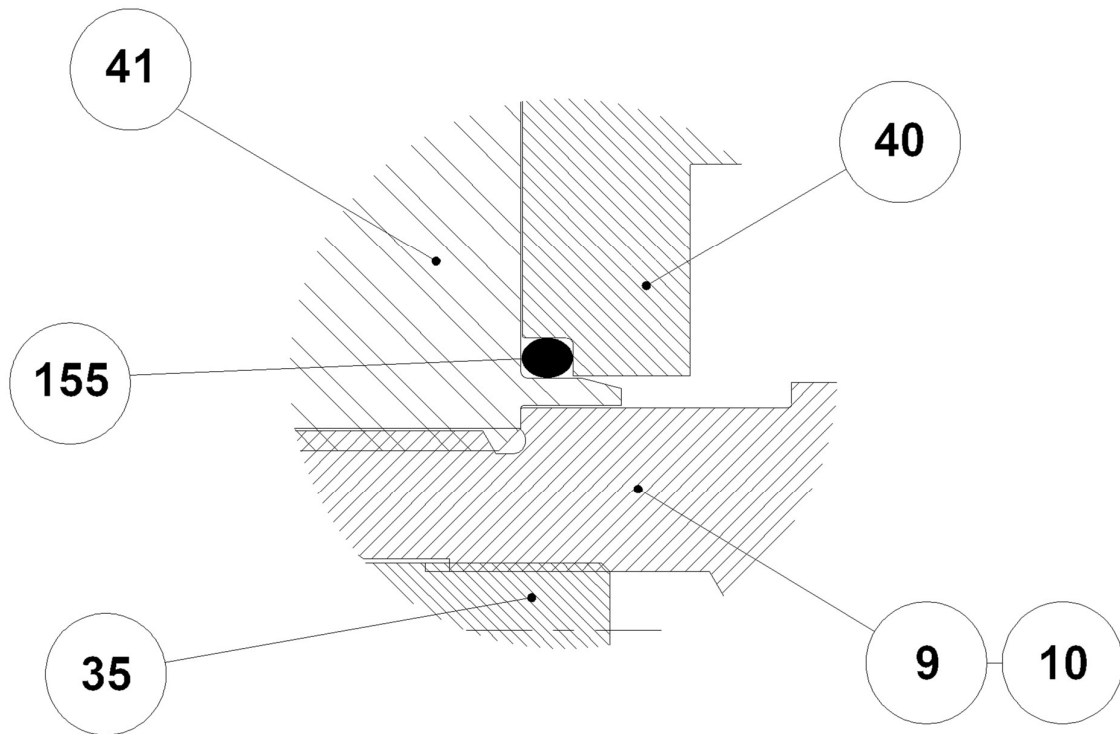
4.3.10 Hybrid Single Flushed Mechanical Seal Fig 37



- During Pump assembly fit the seal housing (28) to the rotorcase securing with screws (26) tightening to correct torque, refer to section 5.2. Ensure the gasket or o-ring (27) are in place before tightening screws (26)
- Install o-ring (49) into the seal carrier (44).
- Install lip seal (43) into the seal carrier (44) and secure using the retainer clip (42).
- Install seal assembly (comprising parts 42, 43, 44, 49) into the rotorcase, ensure anti-rotation lugs engage.
- Install o-ring (50) into the static seal seat (31).
- Install seal seat assembly (comprising parts 30, 31) to the rotorcase, ensuring that the drive lugs and the drive slots engage.
- Install o-ring (32) into the rotary seal face (33).
- Install seal assembly (comprising parts 32, 33) into the rotor.
- To disassemble reverse the above procedure.
- Before disassembling the seals, ensure pump is fully shutdown, refer to section 3.5.



4.3.11 Strip Clean Single O-ring Seal
Fig 38



- Install o-ring (155) into the rotorcase (40).

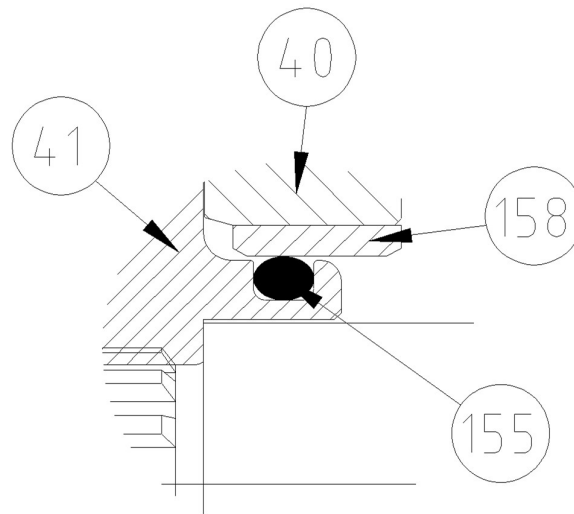
Note: - During installing of the rotors to shafts care must be taken not to damage or unseat the o-ring seal when inserting the rotor (41) into o-ring (155).

- To disassemble reverse the above procedure.



- Before disassembling the seals, ensure pump is fully shutdown, refer to section 3.5.

4.3.12 Duralobe Single O-ring Seal OL1 (S1)
Fig 39



- Install Sleeve (158) into the Rotorcase (40).

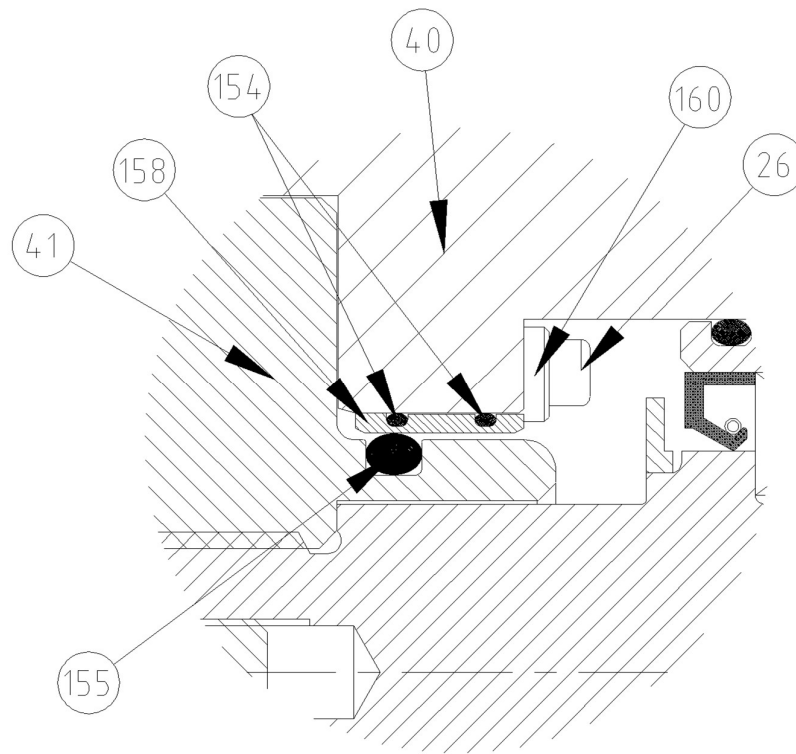
Press the sleeve in from the front of the rotorcase until flush with the back face of the rotorcase.

Note:- Use Loctite 640 or a similar compound to seal the sleeve when pressing in into the rotorcase – Also note that the sleeve is a press fit so ensure that the sleeve is square when pressing it into the rotorcase.

- Install O-ring (155) into the Rotor (41).
- Install the rotor (41) onto the shaft making sure not to damage the o-ring (155).
- To disassemble reverse the above procedure.
- Before disassembling the seals, ensure pump is fully shutdown, refer to section 3.5.



4.3.13 Duralobe Single O-ring Seal OL2, OL3, OL4 (S2, S3, S4)
Fig 41



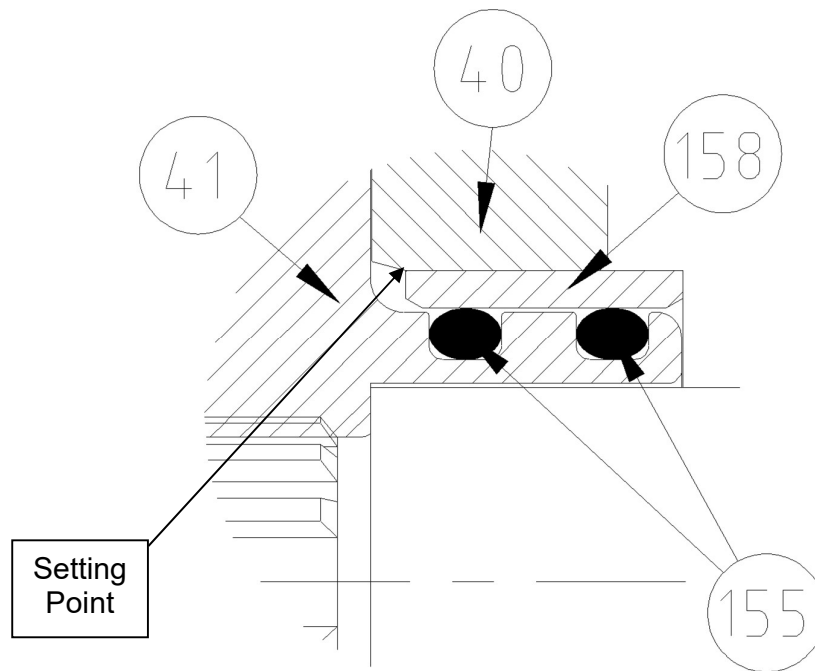
- During Pump assembly fit the stop washers (160) to the rotorcase securing with screws (26) tightening to correct torque, refer to section 5.2.
- Install O-rings (154) to Rotorcase sleeve (158).
- Install Sleeve assembly (comprising parts 154, 158) to Rotorcase (40).

Note:- that the sleeve is a press fit so ensure that the sleeve is square when pressing it into the rotorcase and it is against the stop washers.

- Install O-ring (155) into the Rotor (41).
- Install the rotor (41) onto the shaft making sure not to damage the o-ring (155).
- To disassemble reverse the above procedure.
- Before disassembling the seals, ensure pump is fully shutdown, refer to section 3.5.



4.3.14 MK2 Double O-ring Seal OL1 (S1)
Fig 40



- Install Sleeve (158) into the Rotorcase (40).

Press the sleeve in from the front of the rotorcase and line the front of the sleeve up with the end of chamfer see above setting point

Note:- Use Loctite 640 or a similar compound to seal the sleeve when pressing in into the rotorcase – Also note that the sleeve is a press fit so ensure that the sleeve is square when pressing it into the rotorcase.

- Install O-rings (155) into the Rotor (41).

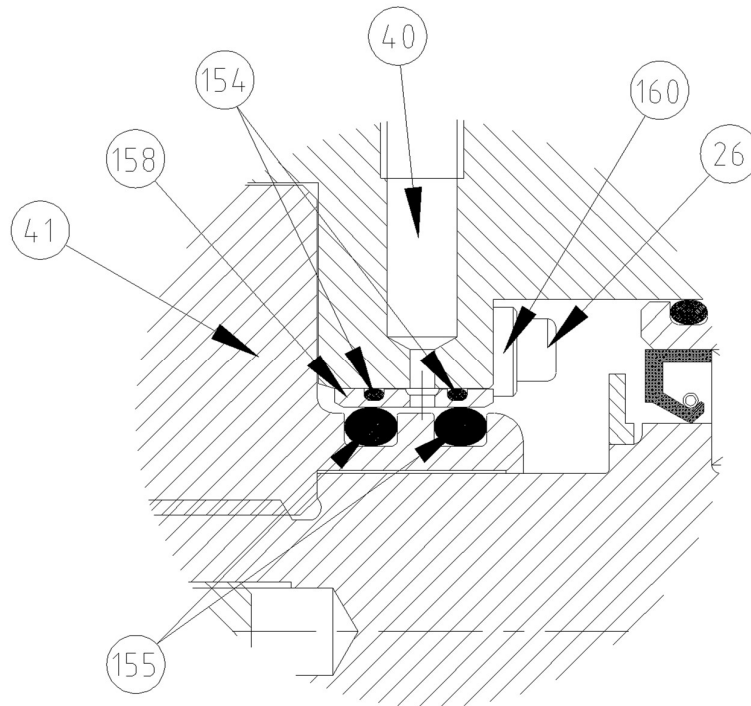
Note:- When using the double seal ensure that the correct lubricant is used to lubricate the o-rings

- Install the rotor (41) onto the shaft making sure not to damage the o-ring (155).
- To disassemble reverse the above procedure.



- Before disassembling the seals, ensure pump is fully shutdown, refer to section 3.5.

4.3.15 MK2 Double O-ring Seal OL2, OL3, OL4 (S2, S3, S4)
Fig 42



- During Pump assembly fit the stop washers (160) to the rotorcase securing with screws (26) tightening to correct torque, refer to section 5.2.
- Install O-rings (154) onto the rotorcase sleeve (158).
- Install Sleeve assembly (comprising parts 154, 158) Into the Rotorcase (40).

Note:- that the sleeve is a press fit so ensure that the sleeve is square when pressing it into the rotorcase and it is against the stop washers.

- Install O-ring (155) onto the Rotor (41).
- Install the rotor (41) onto the shaft making sure not to damage the o-ring (155).
- To disassemble reverse the above procedure.
- Before disassembling the seals, ensure pump is fully shutdown, refer to section 3.5.



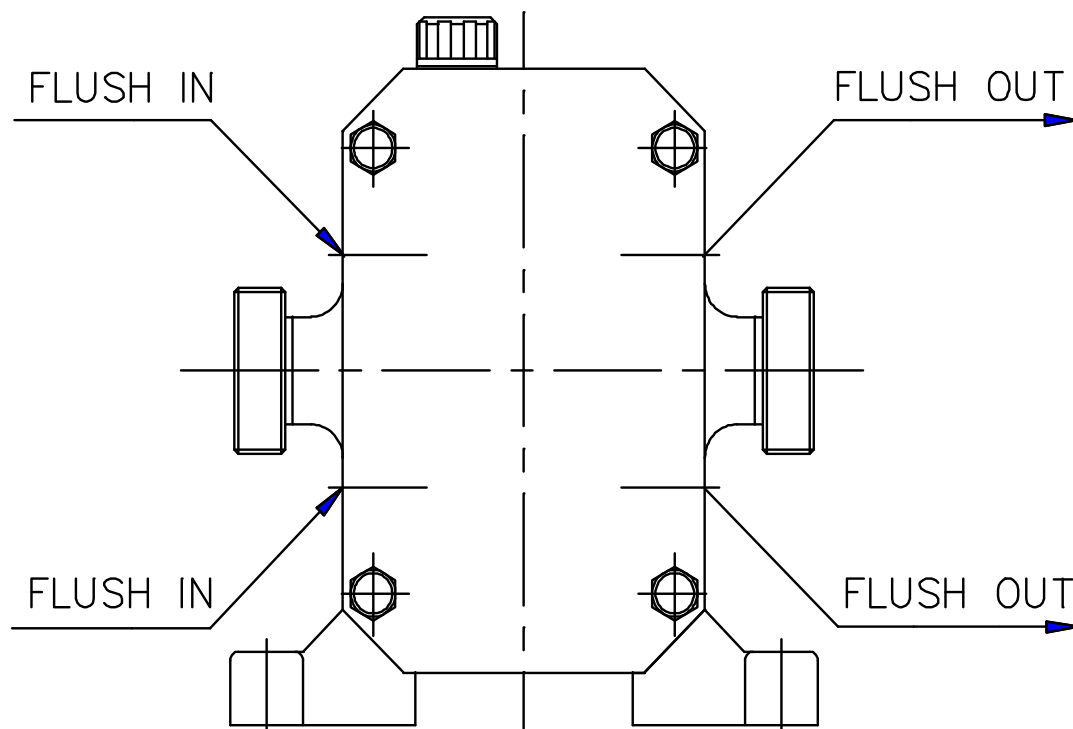
4.3.16 Flushed Product Seal - Auxiliary Services.

Every On Line / Duralobe pump is provided with four seal flushing connections, two on each side of the rotorcase, which are tapped 1/8" BSP.

There are two flushing connections for each seal, one for flush 'in', the other for flush 'out', see fig 33 and the piping for the flush should be arranged to provide an independent flush to each seal.

Pumps are supplied with blanking plugs in each flushing connection. If the pump has been converted to a flushed product seal, these plugs can be removed and the flush connections used to provide the appropriate flush.

Fig 33



i) Terminology.

a) "Quench"

- To provide a liquid barrier that is not induced to flow through the seal area by any external means.

b) "Flush"

- To provide a liquid barrier that is induced to flow through the seal area by an external means.

ii) Quench or Flush Media.

WARNING

The media used for quenching or flushing a seal area must be fully compatible with the pumped media, and the relevant materials of construction of the pump.



Special consideration must be given to the temperature limitations of the media to ensure that no hazards are created, e.g. risk of fire or explosion.

iii) Single Mechanical Seal (For low-pressure Quench or Flush).

Refer to section 4.3.3.

This seal arrangement requires a supply of media to the outboard side of the mechanical seal to quench or flush the seal area. The nature of the pumped media and the specific duty conditions will determine whether a quench or a flush is required.

A quench provides a static head. The quench media vessel should be mounted a minimum of 0.5m (1.5 feet) above the pump, preferably directly above the seal area. The interconnecting pipework should be as straight as possible, avoiding horizontal runs, and with the minimum number of bends and restrictions.

For a suitable flush, the media must be supplied at a flow rate of three litres per minute per shaft seal (0.8 US Gal per min).

WARNING

Note: The limiting flush or quench pressure in any application is 0.5 Bar (7 psi).

iv) Double Mechanical Seal (For High Pressure Flush).

Refer to section 4.3.4.

This seal arrangement requires a supply of media to be circulated between the inboard and outboard mechanical seals.

$$Q = \frac{(0.6 \times p + 0.25) \times n \times d^3 \times T}{c_p \times \rho \times 2.5 \times 10^9}$$

Q = Flow rate	[l/hr]
p = Applied buffer / barrier pressure	[bar]
n = Shaft speed	[rpm]
d = Shaft diameter	[mm]
T = Temperature of processed media	[°C]
ρ = Specific gravity of buffer / barrier fluid	[kg/dm ³]
c _p = Specific heat capacity for buffer / barrier fluid	[kJ/(kg x K)]

Typical values for some common barrier fluids:

Media	Density [kg/dm ³]	Specific Heat [kJ/(kg x K)]
Water	1.0	4.2
Olive Oil	0.9	1.6
Mineral Oil	0.9	1.7
Acetone	0.8	2.2

The flush media must be supplied at a minimum flow rate of 0.5 Litres/ Minute per seal, this can be worked out by the following equation where “Q” is the flow rate.

The flush pressure must be a minimum of 1 Bar (15 psi) greater than the maximum discharge pressure created by, or the maximum suction pressure applied to, the pump, whichever is the greater.

WARNING

Note: The limiting flush pressure in any application is 16 Bar (240 psi.)

v) Double O-ring Seal (For High Pressure Flush).

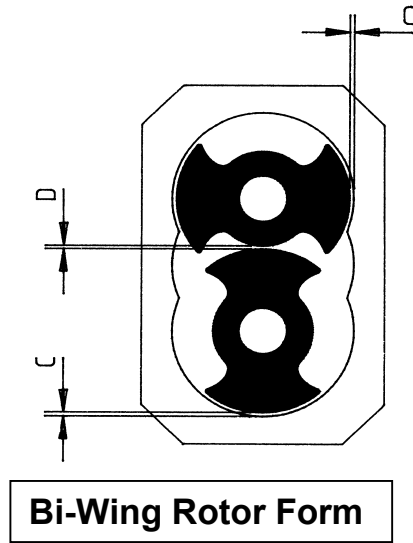
Refer to section 4.3.6.

This seal arrangement requires a supply of media to be circulated between the inboard and outboard o-rings. The flush media must be supplied at a flow rate of three litres per minute per shaft seal assembly (0.8 US Gal per min). **The flush pressure must be a minimum of 1 Bar (15 psi) greater than the maximum discharge pressure created by, or the maximum suction pressure applied to, the pump, whichever is the greater.**

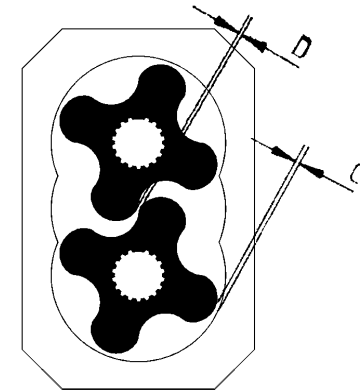
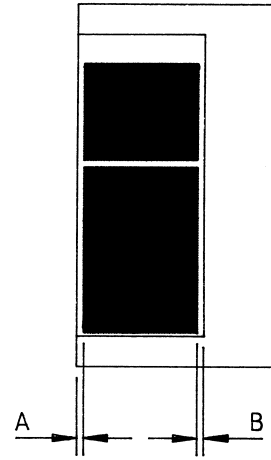
WARNING

Note: The limiting flush pressure in any application is 16 Bar (240 psi.)

5.0 Specifications.
5.1 Clearance Chart



Bi-Wing Rotor Form



Multi-lobe Rotor Form

MODEL	MAXIMUM		MILLIMETERS (x 0.01)								INCH (x 0.001)									
			Bar	° C (° F)	FRONT		REAR		TOP/SIDE		MESH		FRONT		REAR		TOP/SIDE		MESH	
					A	B	C	D	A	B	C	D								
OL1/0004/15 (S1S)	15	150 (300)	9.0	10.0	6.0	12.7	9.0	15.0	7.0	13.0	3.5	3.9	2.4	5.0	3.5	5.9	2.8	5.1		
OL1/0006/10 (S1M)	10	150 (300)	9.0	10.0	6.0	15.0	9.0	15.0	7.0	13.0	3.5	3.9	2.4	5.9	3.5	5.9	2.8	5.1		
OL1/0008/07 (S1L)	7	150 (300)	11.0	12.0	8.0	15.9	12.0	18.0	11.0	16.0	4.3	4.7	3.1	6.3	4.7	7.1	4.3	6.3		
OL2/0017/15 (S2S)	15	150 (300)	14.0	16.0	12.0	20.6	13.0	21.0	15.0	22.0	5.5	6.3	4.7	8.1	5.1	8.3	5.9	8.7		
OL2/0025/10 (S2M)	10	150 (300)	14.0	16.0	13.0	22.3	13.0	21.0	15.0	22.0	5.5	6.3	5.1	8.8	5.1	8.3	5.9	8.7		
OL2/0034/07 (S2L)	7	150 (300)	15.0	17.0	13.0	24.2	17.0	25.0	18.0	26.0	5.9	6.7	5.1	9.5	6.7	9.8	7.1	10.2		
OL3/0054/15 (S3S)	15	150 (300)	19.0	21.0	18.0	28.0	20.0	30.0	21.0	29.0	7.5	8.3	7.1	11.0	7.9	11.8	8.3	11.4		
OL3/0081/10 (S3M)	10	150 (300)	20.0	22.0	18.0	30.0	20.0	30.0	21.0	29.0	7.9	8.7	7.1	11.8	7.9	11.8	8.3	11.4		
OL3/0108/07 (S3L)	7	150 (300)	20.0	23.0	19.0	32.0	24.0	33.0	25.0	33.0	7.9	9.1	7.5	12.6	9.4	13.0	9.8	13.0		
OL4/0162/15 (S4S)	15	150 (300)	26.0	30.0	25.0	40.0	30.0	43.0	32.0	40.0	10.2	11.8	9.8	15.7	11.8	16.9	12.6	15.7		
OL4/0243/10 (S4M)	10	150 (300)	29.0	33.0	27.0	42.0	30.0	43.0	32.0	40.0	11.4	13.0	10.6	16.5	11.8	16.9	12.6	15.7		
OL4/0324/07 (S4L)	7	150 (300)	30.0	35.0	27.0	44.0	34.0	47.0	36.0	44.0	11.8	13.8	10.6	17.3	13.4	18.5	14.2	17.3		

5.2 Fasteners & Torque Settings.

Item No.	Description	Position		OL1 (S1)	OL2 (S2)	OL2 (S2) GLAXO	OL3 (S3)	OL4 (S4)
2	Socket Head Cap Screw	Foot / Rotorcase	Quantity / Pump Size Torque Nm	4 M8 x 12 17	4 M10 x 16 45	4 M10 x 16 45	4 M10 x 20 45	4 M16 x 25 100
7	Socket Head Cap Screw	Gearbox / Rotorcase	Quantity / Pump Size Torque Nm	4 M6 x 30 7	4 M8 x 45 17	4 M8 x 45 17	4 M10 x 50 45	8 M10 x 55 45
12	Lock Nut (See 1.0)	Bearing / Shaft	Quantity / Pump Size	2 M20 x 1.0	2 M35 x 1.5	2 M35 x 1.5	2 M45 x 1.5	2 M65 x 2.0
			Rolling Torque Nm	1 – 1.5	2 – 2.5	3 - 3.5	3 – 3.5	5.5 – 6
23	Socket Head Cap Screw	Bearing Sleeve / Rotorcase	Quantity / Pump Size Torque Nm	6 M6 x 22 16	6 M8 x 30 25	6 M8 x 30 25	6 M12 x 50 80	6 M16 x 55 100
26	Socket Head Cap Screw	Housing / Rotorcase	Quantity / Pump Size Torque Nm	8 M4 x 8 5.5	8 M5 x 12 10	8 M5 x 12 10	8 M6 x 16 16	12 M6 x 20 16
35	Retainer	Rotor / Shaft	Quantity / Pump Torque Nm	2 (M10) 30	2 (M12) 40	2 (M12) 40	2 (M16) 108	2 (M24) 169
36	Dome Nut (Acorn)	Front Cover / Rotorcase	Quantity / Pump Size Torque Nm	4 M8 17	4 M10 45	4 M10 45	4 M12 55	8 M12 55
37	Stud	Front Cover / Rotorcase	Quantity / Pump Size Torque Nm	4 M8 x 35 17	4 M10 x 35 45	4 M10 x 35 45	4 M12 x 52 55	8 M12 x 57 55
56	Hammer Drive Screw	Nameplate / Gearbox	Quantity / Pump	4	4	4	4	4
110A	Socket Head Cap Screw	RV Cylinder /Front	Quantity / Pump Size Torque Nm	N/A	N/A	N/A	N/A	8 M16 x 50 55
110B	Socket Head Cap Screw	RV Cylinder /Nut	Quantity / Pump Size Torque Nm	N/A	N/A	N/A	N/A	10 M10 x 25 45
118	Socket Head Cap Screw	RV Cylinder /Front	Quantity / Pump Size Torque Nm	6 M6 x 70 7	6 M6 x 80 7	6 M6 x 80 7	6 M10 x 80 45	6 M16 x 110 100
120	Socket Head Cap Screw	Piston RV Head	Quantity / Pump Size Torque Nm	1 M10 x 55 45	1 M12 x 60 55	1 M12 x 60 55	1 M16 x 55 100	1 M12 x 65 55

Notes: 1.0) Rolling torque quoted for nut, item 12 (reference section 4.2.1)
2.0) For position of items see section 5.6, typical basic pump build

5.3 Lubricants.

Gearbox oil recommended for use with On Line / Duralobe pumps is an “EP (Extreme Pressure) grade gear lube” for the following ambient temperature ranges.

EP150	-17°C – 0°C (0 – 32°F)
EP220	0°C – 30°C (32 – 85°F)
EP320	30°C (85°F) and higher

Approximate pump gearbox capacities for On Line / Duralobe pumps:

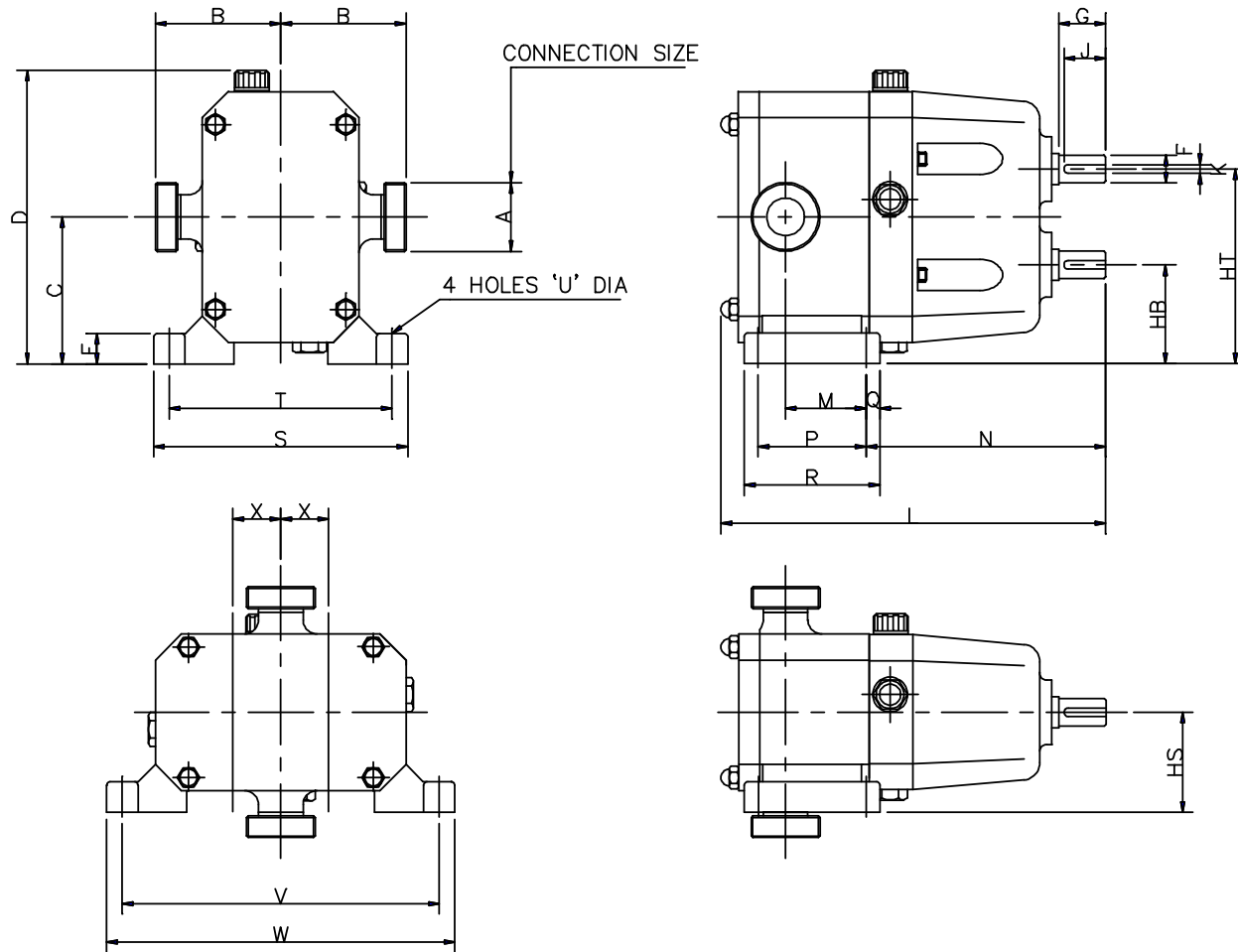
Pump Model	Mounting Attitude			
	Suction and Discharge Ports in:			
	Horizontal Plane		Vertical Plane	
	Litres	US Pints	Litres	US Pints
OL1 (S1)	0.3	0.6	0.3	0.6
OL2 (S2)	1.1	2.4	1.1	2.4
OL3 (S3)	3	6.3	2.55	5.4
OL4 (S4)	7.55	16	5.7	12

Always add oil to the level of the sight glass. The sight glass must be located in the uppermost position on the side of the gearbox cover. DO NOT OVERFILL.

5.4 Material Specification.

Rotors	316 Stainless Steel
Rotorcase	316 Stainless Steel
Shafts	316 Stainless Steel
Front Cover	316 Stainless Steel
Rotor Retainer	316 Stainless Steel
Gearbox Cover	Grade 220 Grey Cast Iron or 316 Stainless Steel
Bearing Sleeve	070 M20 Steel – OL1, OL2 & OL3 (S1, S2 & S3) Grade 220 Grey Cast Iron – OL4 (S4)

5.5 On Line / Duralobe Foundation Dimensions.



Dimensions in Millimetres

MODEL	5A5	B1	Or B2	B3	B4	B5	C	D	E	F	G	HB	HS	HT	J	K	L	M	N	P	Q	R	S	T	U	V	W	X	Weight (KGs)
OL1/0004/15	25	85	85	99	99	99	84.5	176	17	16 j6	28	57	57	112	24	5	223	46	138	62	8	78	146	128	9	183	201	27.5	11.8
OL1/0006/10	25	85	85	99	99	99	84.5	176	17	16 j6	28	57	57	112	24	5	232	53	138	62	8	78	146	128	9	183	201	27.5	12.1
OL1/0008/07	25	85	85	99	99	99	84.5	176	17	16 j6	28	57	57	112	24	5	240	61	138	62	8	78	146	128	9	183	201	27.5	12.3
OL2/0017/15	40	107	129	121	121	121	118	246	21	28 j6	42	75	75	160	38	8	317	65	197	90	14	117	197	170	11	255	282	42.5	34
OL2/0025/10	50	107	129	121	121	121	118	246	21	28 j6	42	75	75	160	38	8	331	74	197	90	14	117	197	170	11	255	282	42.5	37
OL2/0034/07	50	107	129	121	121	121	118	246	21	28 j6	42	75	75	160	38	8	345	87	197	90	14	117	197	170	11	255	282	42.5	39
OL3/0054/15	50	131	153	145	145	145	157	324	29	38 k6	80	100	100	215	70	10	435	83	274	124	14	152	243	214	13	329	358	57.5	80
OL3/0081/10	80	131	163	145	153	158	157	324	29	38 k6	80	100	100	215	70	10	456	95	274	124	14	152	243	214	13	329	358	57.5	84
OL3/0108/07	80	131	163	145	153	158	157	324	29	38 k6	80	100	100	215	70	10	480	115	274	124	14	152	243	214	13	329	358	57.5	88
OL4/0162/15	80	178	210	192	200	205	216	442	30	60 m6	140	136	147	296	129	18	581	109	375	170	16	202	378	342	18	480	516	80	213
OL4/0243/10	100	182	225	192	200	205	216	442	30	60 m6	140	136	147	296	129	18	612	127	375	170	16	202	378	342	18	480	516	80	237
OL4/0324/07	100	182	225	192	200	205	216	442	30	60 m6	140	136	147	296	129	18	643	151	375	170	16	202	378	342	18	480	516	80	260

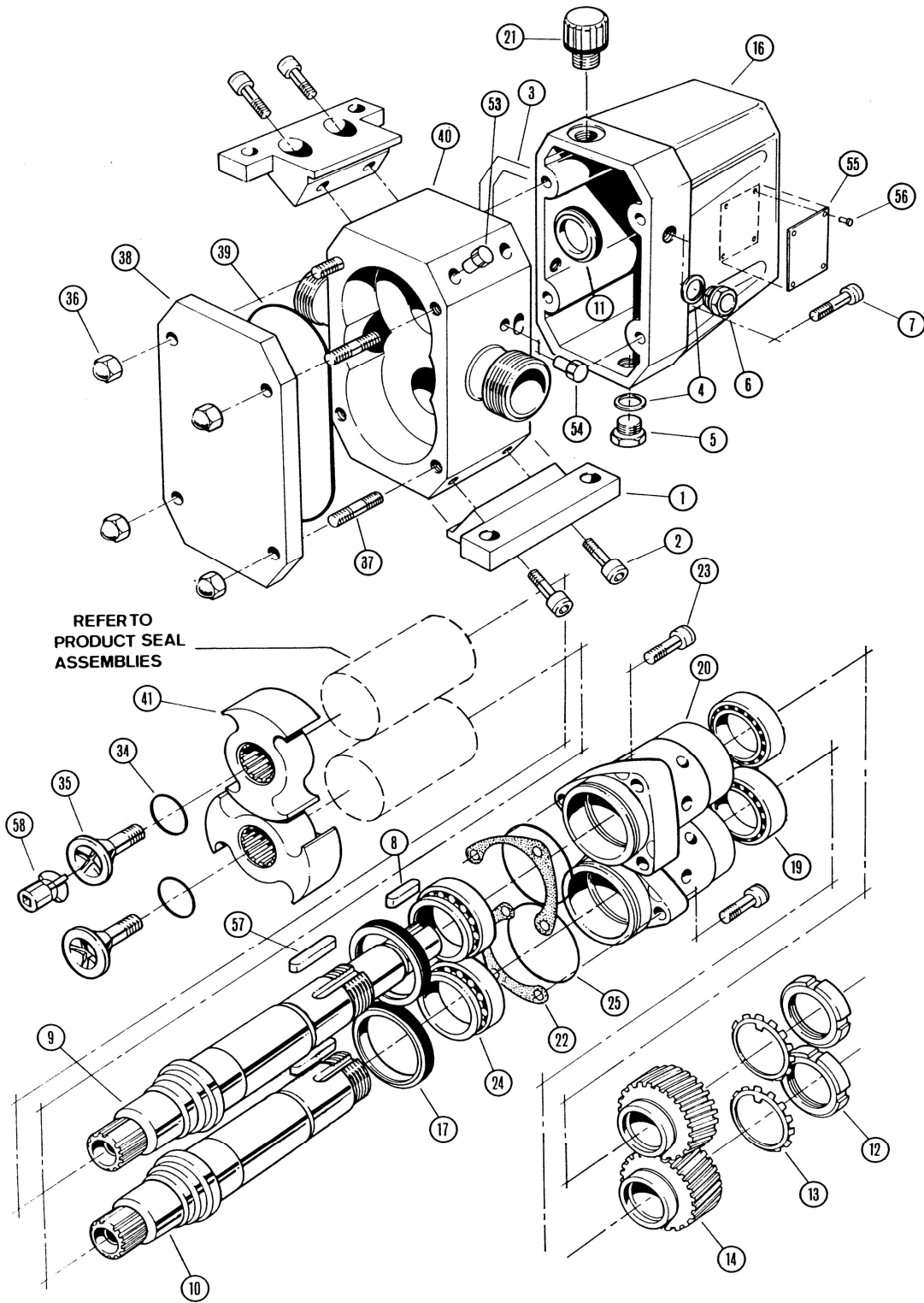
Dimensions in Inches (except F and K)

MODEL	A	B1	B2	B3	B4	B5	C	D	E	F (mm)	G	HB	HS	HT	J	K (mm)	L	M	N	P	Q	R	S	T	U	V	W	X	Weight (lbs.)
OL1/0004/15	1	3.35	3.35	3.9	3.9	3.9	3.33	6.93	0.67	16 j6	1.1	2.24	2.24	4.41	0.94	5	8.78	1.81	5.43	2.44	0.31	3.07	5.75	5.04	0.35	7.2	7.91	1.08	26
OL1/0006/10	1	3.35	3.35	3.9	3.9	3.9	3.33	6.93	0.67	16 j6	1.1	2.24	2.24	4.41	0.94	5	9.13	2.09	5.43	2.44	0.31	3.07	5.75	5.04	0.35	7.2	7.91	1.08	26
OL1/0008/07	1	3.35	3.35	3.9	3.9	3.9	3.33	6.93	0.67	16 j6	1.1	2.24	2.24	4.41	0.94	5	9.45	2.4	5.43	2.44	0.31	3.07	5.75	5.04	0.35	7.2	7.91	1.08	27
OL2/0017/15	1.5	4.21	5.08	4.76	4.76	4.76	4.65	9.69	0.83	28 j6	1.65	2.95	2.95	6.3	1.5	8	12.48	2.56	7.76	3.54	0.55	4.61	7.76	6.69	0.43	10.04	11.1	1.67	75
OL2/0025/10	2	4.21	5.08	4.76	4.76	4.76	4.65	9.69	0.83	28 j6	1.65	2.95	2.95	6.3	1.5	8	13.03	2.91	7.76	3.54	0.55	4.61	7.76	6.69	0.43	10.04	11.1	1.67	81
OL2/0034/07	2	4.21	5.08	4.76	4.76	4.76	4.65	9.69	0.83	28 j6	1.65	2.95	2.95	6.3	1.5	8	13.58	3.43	7.76	3.54	0.55	4.61	7.76	6.69	0.43	10.04	11.1	1.67	86
OL3/0054/15	2	5.16	6.02	5.71	5.71	5.71	6.18	12.76	1.14	38 k6	3.15	3.94	3.94	8.46	2.76	10	17.13	3.27	10.79	4.88	0.55	5.98	9.57	8.43	0.51	12.95	14.09	2.26	176
OL3/0081/10	3	5.16	6.42	5.71	6.02	6.22	6.18	12.76	1.14	38 k6	3.15	3.94	3.94	8.46	2.76	10	17.95	3.74	10.79	4.88	0.55	5.98	9.57	8.43	0.51	12.95	14.09	2.26	185
OL3/0108/07	3	5.16	6.42	5.71	6.02	6.22	6.18	12.76	1.14	38 k6	3.15	3.94	3.94	8.46	2.76	10	18.9	4.53	10.79	4.88	0.55	5.98	9.57	8.43	0.51	12.95	14.09	2.26	194
OL4/0162/15	3	7.01	8.27	7.56	7.87	8.07	8.5	17.4	1.18	60 m6	5.51	5.35	5.79	11.65	5.08	18	22.87	4.29	14.76	6.69	0.63	7.95	14.88	13.46	0.71	18.9	20.31	3.15	469
OL4/0243/10	4	7.17	8.86	7.56	7.87	8.07	8.5	17.4	1.18	60 m6	5.51	5.35	5.79	11.65	5.08	18	24.09	5	14.76	6.69	0.63	7.95	14.88	13.46	0.71	18.9	20.31	3.15	522
OL4/0324/07	4	7.17	8.86	7.56	7.87	8.07	8.5	17.4	1.18	60 m6	5.51	5.35	5.79	11.65	5.08	18	25.31	5.94	14.76	6.69	0.63	7.95	14.88	13.46	0.71	18.9	20.31	3.15	573

Notes: Dimensions given are for guidance only and should not be used for installation purposes.
 Certified dimensions will be supplied on request

B1 applies for all threaded connections except BSPT and NPT
 B2 applies for BSPT and NPT thread connections
 B3 applies for all flange connections except ASA150, BS4504 and ASA300
 B4 applies for ASA150 and BS4504 flange connections
 B5 applies for ASA300 flange connections

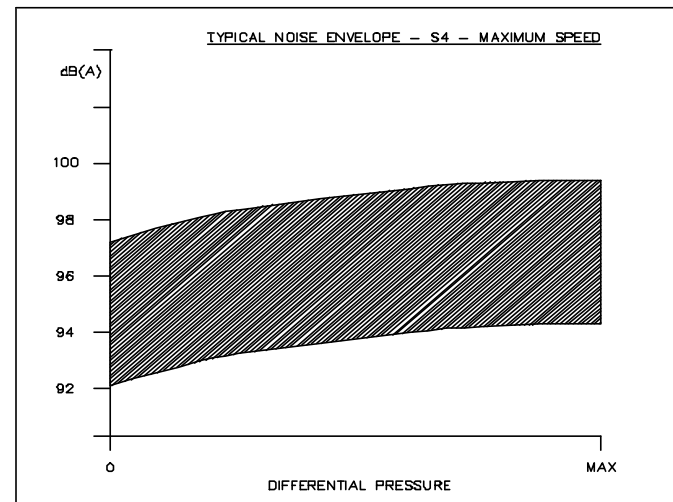
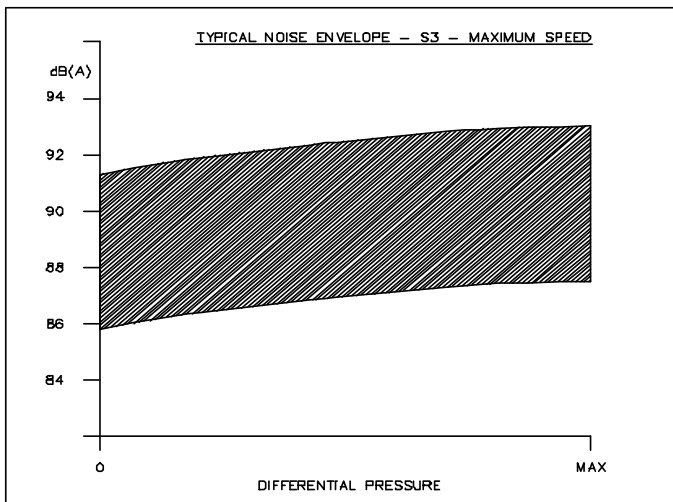
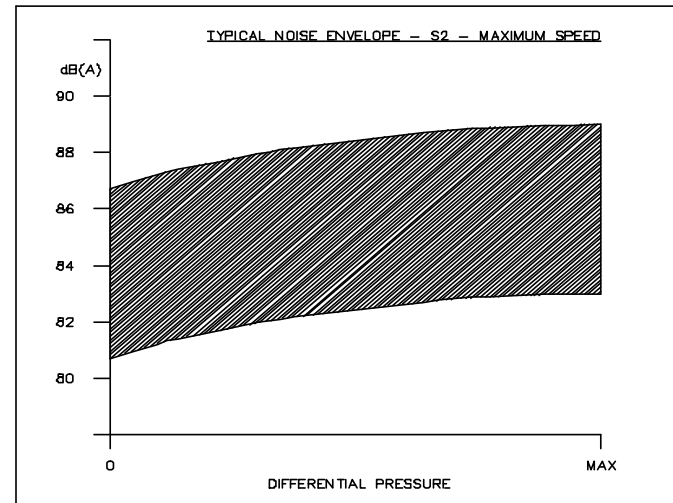
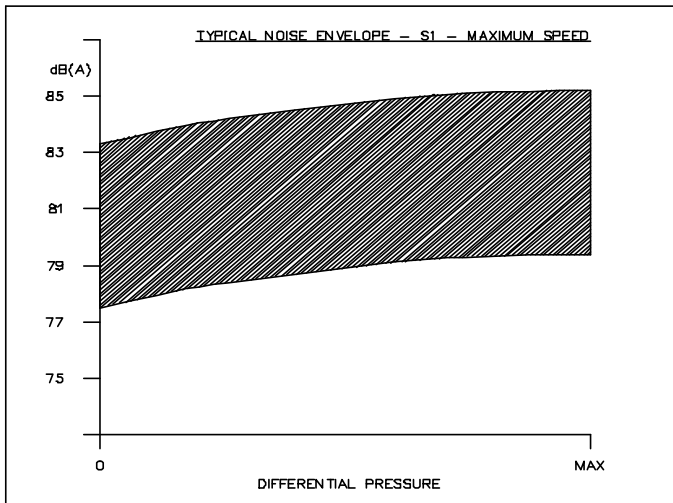
5.6 Typical Basic Pump Build.



5.7 Trouble Shooting.

No FLOW	IRREGULAR FLOW	UNDER CAPACITY	PUMP OVERHEATS	MOTOR OVERHEATS	EXCESSIVE ROTOR WEAR	EXCESSIVE SEAL WEAR	NOISE / VIBRATION	SEIZURE	PUMP STALLS ON START UP	Causes	ACTION
										INCORRECT DIRECTION OF ROTATION.	REVERSE MOTOR.
										PUMP NOT PRIMED.	EXPEL GAS FROM SUCTION LINE / PUMP CHAMBER & PRIME.
										INSUFFICIENT NPSH AVAILABLE.	INCREASE SUCTION LINE & STATIC SUCTION HEAD DIAMETER. SIMPLIFY SUCTION LINE & REDUCE LENGTH. REDUCE PUMP SPEED & PRODUCT TEMPERATURE.
										PRODUCT VAPORISING IN SUCTION LINE.	
										AIR ENTERING SUCTION LINE.	REMAKE PIPEWORK JOINTS.
										GAS IN SUCTION LINE.	EXPEL GAS FROM SUCTION LINE / PUMP CHAMBER.
										INSUFFICIENT STATIC SUCTION HEAD.	RAISE PRODUCT LEVEL TO INCREASE STATIC SUCTION HEAD.
										PRODUCT VISCOSITY TOO HIGH.	DECREASE PUMP SPEED / INCREASE PRODUCT TEMPERATURE.
										PRODUCT VISCOSITY TOO LOW.	INCREASE PUMP SPEED / INCREASE PRODUCT TEMPERATURE.
										PRODUCT TEMPERATURE TOO HIGH.	COOL PRODUCT / PUMPING CHAMBER.
										PRODUCT TEMPERATURE TOO LOW.	HEAT PRODUCT / PUMPING CHAMBER.
										UNEXPECTED SOLIDS IN PRODUCT	CLEAN SYSTEM / FIT STRAINER ON SUCTION SIDE OF PUMP.
										DISCHARGE PRESSURE TOO HIGH	CHECK FOR BLOCKAGES / SIMPLIFY DISCHARGE LINE.
										ROTORCASE STRAINED BY PIPEWORK.	CHECK PIPE ALIGNMENT / SUPPORT PIPEWORK.
										PUMP SPEED TOO HIGH	DECREASE PUMP SPEED.
										PUMP SPEED TOO LOW	INCREASE PUMP SPEED
										SEAL FLUSH INADEQUATE	INCREASE SEAL FLUSH TO REQUIRED PRESSURE / FLOW.
										BEARING / TIMING GEAR WEAR	REPLACE WORN COMPONENTS.

5.8 Typical Noise Emission Data.



5.10 Tool List.

Listed below are tools required for the maintenance of the On Line / Duralobe pump.

TYPE	SIZE OR RANGE	OL1 (S1)	OL2 (S2)	OL3 (S3)	OL4 (S4)
COMBINATION WRENCH	13mm				
COMBINATION WRENCH	17MM				
COMBINATION WRENCH	19MM				
COMBINATION WRENCH	24MM				

HEXAGON (ALLEN) KEY	1/4"				
HEXAGON (ALLEN) KEY	3/8"				
HEXAGON (ALLEN) KEY	3MM				
HEXAGON (ALLEN) KEY	4MM				
HEXAGON (ALLEN) KEY	5MM				
HEXAGON (ALLEN) KEY	6MM				
HEXAGON (ALLEN) KEY	8MM				
HEXAGON (ALLEN) KEY	10MM				
HEXAGON (ALLEN) KEY	14MM				

HEXAGON (ALLEN) KEY - SOCKET DRIVEN	3MM				
HEXAGON (ALLEN) KEY - SOCKET DRIVEN	4MM				
HEXAGON (ALLEN) KEY - SOCKET DRIVEN	5MM				
HEXAGON (ALLEN) KEY - SOCKET DRIVEN	6MM				
HEXAGON (ALLEN) KEY - SOCKET DRIVEN	8MM				
HEXAGON (ALLEN) KEY - SOCKET DRIVEN	10MM				
HEXAGON (ALLEN) KEY - SOCKET DRIVEN	14MM				

TYPE	SIZE OR RANGE	OL1 (S1)	OL2 (S2)	OL3 (S3)	OL4 (S4)
TORQUE WRENCH	ADJUSTABLE UP TO MINIMUM 39 NM (28.765 FT-LB)				
TORQUE WRENCH	ADJUSTABLE UP TO MINIMUM 77 NM (56.792 FT-LB)				
TORQUE WRENCH	ADJUSTABLE UP TO MINIMUM 135 NM (99.571 FT-LB)				
TORQUE WRENCH	ADJUSTABLE UP TO MINIMUM 180 NM (132.761 FT-LB)				
DEPTH MICROMETER	0 - 25 MM (0 - 1")				
FEELER GAUGE SET					
ROLLING TORQUE METER	0 - 5 NM (0 - 3.688 FT-LB)				
ROLLING TORQUE METER	0 - 10 NM (0 - 7.376 FT-LB)				
SOCKET FOR ROTOR RETAINER	SUPPLIED WITH PUMP				
RELEASE BAR FOR SEAL FACES	SUPPLIED WITH PUMP				
HOOK WRENCH	TO SUIT LOCKNUT OUTSIDE DIAMETER 32MM (1.26")				
HOOK WRENCH	TO SUIT LOCKNUT OUTSIDE DIAMETER 52MM (2.047")				
HOOK WRENCH	TO SUIT LOCKNUT OUTSIDE DIAMETER 65MM (2.559")				
HOOK WRENCH	TO SUIT LOCKNUT OUTSIDE DIAMETER 85MM (3.346")				
SOFT-FACED MALLET					
PIN PUNCH	SMALL				
STEEL HAMMER	SMALL				

FOR PUMPS WITH RELIEF VALVE INSTALLED

PRY BAR	DIAMETER 8 200 LONG (0.315" BY 7.874" LONG)				
PRY BAR	DIAMETER 13 400 LONG (0.512" BY 15.748")				
PRY BAR	DIAMETER 16 600 LONG (0.63" BY 23.622")				
PIN WRENCH	ADJUSTABLE				

5.11 Notes.

The information contained in this document is correct at time of print but may be subject to change without prior notice. The latest updated copies are available from our website



Viking Pump Hygienic Ltd.

Edison Road, Eastbourne,
East Sussex, BN23 6PT
United Kingdom

Phone: +44 1323 509211
E-mail: vcfcs@idexcorp.com

Viking Pump, Inc.

406 State Street
Cedar Falls, Iowa 50613 U.S.A.

Phone: (319) 268-8013
Fax: (803) 216-7686
E-mail: vcfcs@idexcorp.com

vikingpump.com