

UNIVERSAL PRODUCT LINE: STEEL EXTERNALS — NON-JACKETED PUMPS

123C Series™, 4123C Series™, 323A Series™, 4323A Series™

Section	2301
Page	2301.1
Issue	A

TABLE OF CONTENTS

Related Products	1
Operating Range	1
Series Description	1
Features & Benefits	2
Port Location Options	2
Model Number Key	3
Standard Materials of Construction	3
Cutaway View & Pump Features	4
Special Materials & Options Selection Guidelines	5
Specifications	6
Port Options for ProPort™ Casing	7
Dimensions – H through Q Sizes	8
Dimensions – QS Size	9
Dimensions – N & R Sizes – Jacketed Bracket (323A Series™, 4323A Series™)	10
Dimensions – RS Size – Jacketed Bracket (323A Series™, 4323A Series™)	11
NPSH Required	12

RELATED PRODUCTS

- Steel Externals, Jacketed Pumps: Catalog Section 2302
- Steel Externals, Mag Drive Pumps: Catalog Section 1303
- Cast Iron, Non-Jacketed Pumps: Catalog Section 1401
- Stainless Steel, Non-Jacketed Pumps: Catalog Section 2701
- Steel Externals, Jacketed Pumps (API 682 Seal):
Catalog Section 1304
- Steel Externals, Jacketed Pumps (API 676 Compliant):
Catalog Section 1305

SERIES DESCRIPTION

123C Series™ & 4123C Series™:

The Universal Product Line has the broadest range of sealing options of all pumps built by Viking Pump®. The U-Plus™ bracket design accepts packing as well as numerous component and cartridge seals.

This is Viking Pump's most versatile line of internal gear pumps with many design and material options. These series are available with the ProPort™ casing and a wide variety of flange types and sizes as well as both 90 degree and opposite port arrangements* enabling flexibility when connecting pumps to piping.

323A Series™, 4323A Series™:

Viking's largest product series in the Universal Product Line offers high capacity and a variety of sealing arrangements including component or cartridge seals as well as packing. These products come standard with a jacketed bracket and optional jacketed head.



HL123C



KK4123C

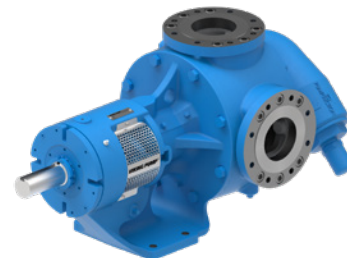

Q4123C

*90 degree port arrangements available in sizes H-Q

OPERATING RANGE

SERIES	NOMINAL FLOW		MAXIMUM PRESSURE		TEMPERATURE RANGE		VISCOSITY RANGE	
	GPM	m³h	PSI	Bar	°F	°C	SSU	cSt
123C Series™	15 - 500	3 - 114	200	14	-20 to +800	-30 to +425	28 to 2,000,000	0.1 to 440,000
4123C Series™	15 - 500	3 - 114	200	14	-20 to +800	-30 to +425	28 to 2,000,000	0.1 to 440,000
323A Series™	600 - 1,600	136 - 364	200	14	-20 to +800	-30 to +425	28 to 2,000,000	0.1 to 440,000
4323A Series™	600 - 1,600	136 - 364	200	14	-20 to +800	-30 to +425	28 to 2,000,000	0.1 to 440,000

Section	2301
Page	2301.2
Issue	A

UNIVERSAL PRODUCT LINE: STEEL EXTERNALS — NON-JACKETED PUMPS

123C Series™, 4123C Series™, 323A Series™, 4323A Series™

FEATURES & BENEFITS

- Positive Displacement Internal Gear pumping principle handles a broad range of viscosities with constant flow rate
- **ProPort™ Casing (123C Series™ & 4123C Series™):**
 - » Adaptable port design offers a variety of ports sizes and types, enabling flexibility when connecting pumps to piping
 - » H-Q sizes available with optional opposite porting
 - » Casing drain allows the pump to be drained without removing the head
 - » Optional O-ring joint seals for high pressure or difficult to seal applications
 - » Internal circulation promotes flow behind the rotor
- **U-Plus™ Bracket (123C Series™ & 4123C Series™):**
 - » Seal options include packing, single component seals, cartridge lip seals and cartridge single and double mechanical seals
 - » Stainless steel window guards offer protection from rotating parts
- Footed one-piece steel bracket provides rigid mounting to help maintain alignment, which extends seal and bearing life
- Series designed with an enlarged bearing housing; used in conjunction with a spacer coupling permits easy cartridge seal installation and removal in place without removing the head and rotor/shaft
- Axial rotor thrust is controlled by double row ball bearing or tapered roller bearings; bushings provide a secondary point of radial shaft support
- Rotatable bearing housing provides easy rotor end clearance adjustment to compensate for viscosity or wear
- Numerous material options are available for bushings, idler pins, shafts, rotors, idlers and elastomers
- Can use direct drive, gear reducer or gearmotor drive, or belt-drive
- Pressure relief valve standard on non-jacketed pumps; less valve / plain head option available

PORT LOCATION OPTIONS

123C Series™, 4123C Series™

90° port options:

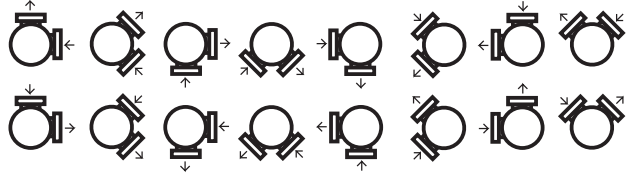

Opposite port options:

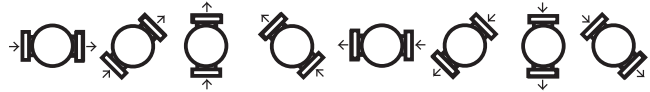

NOTE: See page 2301.7 for a complete list of casing options by size.

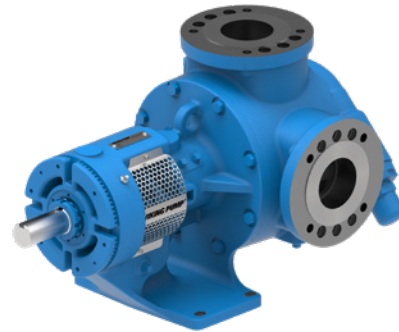

LL123C
90° Ports

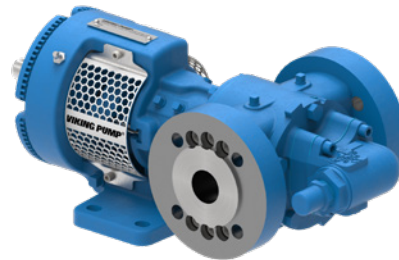

HL123C
Opposite Ports

**3 YEAR LIMITED
WARRANTY**

Viking Universal Product Line pumps carry a three year limited warranty. See catalog section 1000 for details.

UNIVERSAL PRODUCT LINE: STEEL EXTERNALS — NON-JACKETED PUMPS

123C Series™, 4123C Series™, 323A Series™, 4323A Series™

Section	2301
Page	2301.3
Issue	A

MODEL NUMBER KEY

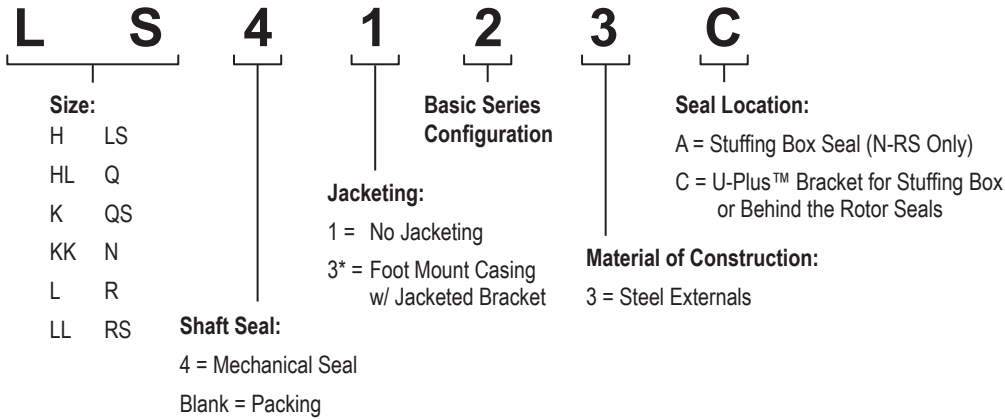

* Note: Only the N through RS sizes are foot mount casing with jacketed bracket.

STANDARD MATERIALS OF CONSTRUCTION

Component	Standard Material	
Casing	Steel, ASTM A216, Class WCB	
Head	Steel, ASTM A216, Class WCB	
Bolt on Ports (Sizes H through QS only)	Steel ASTM A216, Class WCB	
Bracket	Steel, ASTM A216, Class WCB	
Idler	Standard	① Cast Iron, ASTM A148, Class 35B
	Steel Fitted	① ② Cast Iron, ASTM A148, Class 35B
Rotor	Standard	③ Cast Iron, ASTM A148, Class 35B
	Steel Fitted	④ Steel, ASTM A148, Grade 80-40
Shaft	⑤ Steel, ASTM A108, Grade 1045	
Idler Pin	Hardened Steel, ASTM A108, Grade 1045	
Idler Bushing	(4123C, 4323A)	Carbon Graphite
	(123C, 323A)	Bronze, ASTM B584 (B505), Alloy C93700
Bracket Bushing	(4123C, 4323A)	Carbon Graphite
	(123C, 323A)	Bronze, ASTM B584 (B505), Alloy C93700
Pressure Relief Valve	⑥ Steel, ASTM A216, Class WCB	
Standard Packing (123C, 323A)	Braided PTFE	
Standard Mechanical Seal (4123C, 4323A)	Carbon vs. Silicon Carbide Faces, FKM Elastomers	

- ① H and HL sizes have a powdered metal idler: Powdered Metal MPIF 35, FC-0208-50 (G) , Powdered Metal MPIF 35, FC-0208-45 (H, HL)
- ② Q and QS sizes have a hardened steel idler when pump is steel fitted: ASTM A148 Grade 80-40.
- ③ KK, LS, QS, N and RS sizes have ductile iron rotor: ASTM A536 Grade 60-40-18.
- ④ Material specification for HL steel rotor is AISI 8620, LS steel rotor is ASTM A148 80-50.
- ⑤ K, KK, L, LL and LS sizes are high strength steel ASTM A434 Type 4140 Grade BC or equivalent.
- ⑥ L, LL and LS relief valve bodies are stainless steel.

Section	2301
Page	2301.4
Issue	A

UNIVERSAL PRODUCT LINE: STEEL EXTERNALS — NON-JACKETED PUMPS

123C Series™, 4123C Series™, 323A Series™, 4323A Series™

CUTAWAY VIEW & PUMP FEATURES

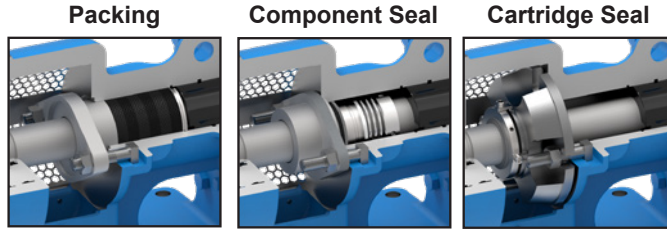

U-Plus™ bracket seal chamber accepts a variety of seal types

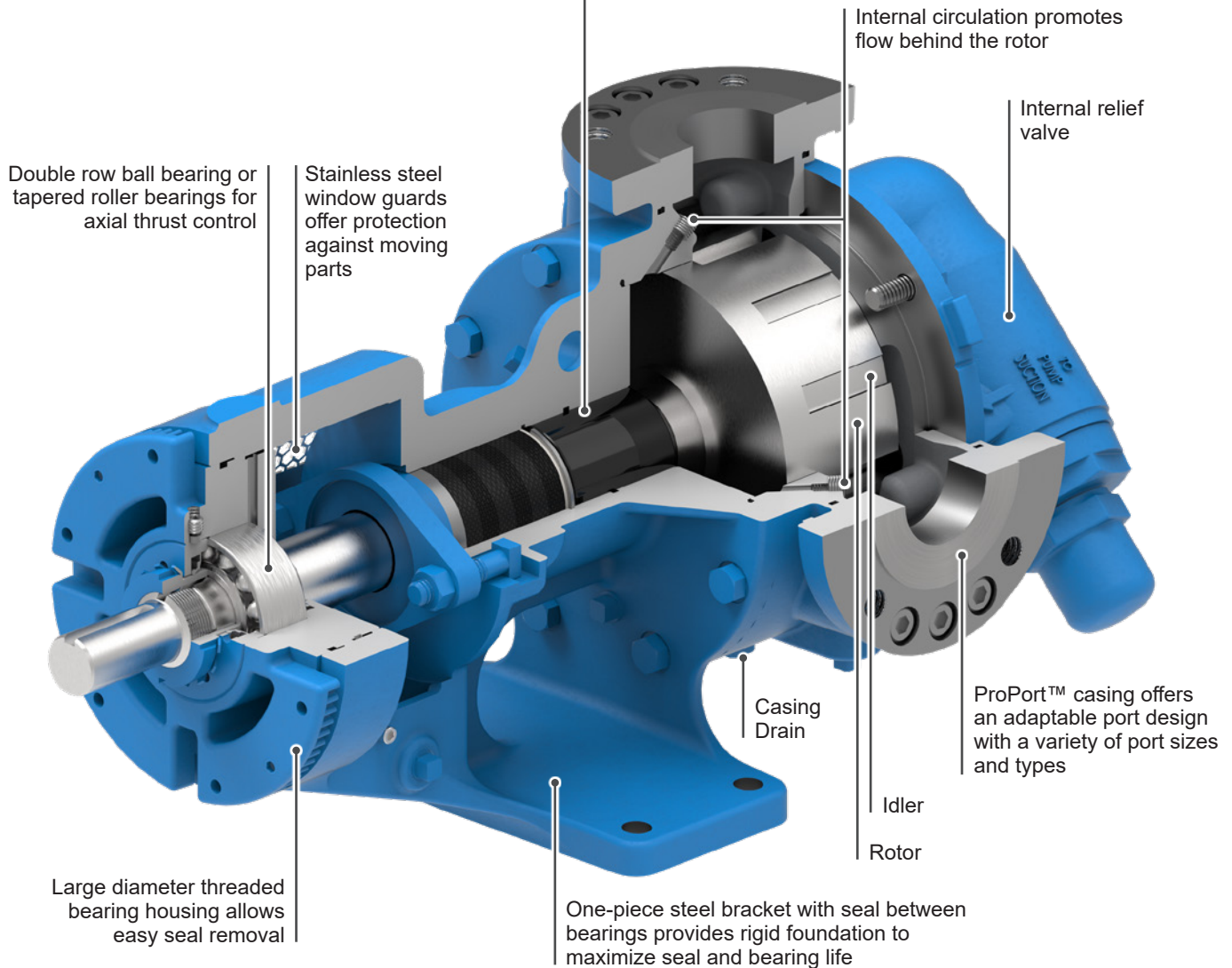

UNIVERSAL PRODUCT LINE: STEEL EXTERNALS — NON-JACKETED PUMPS

123C Series™, 4123C Series™, 323A Series™, 4323A Series™

Section	2301
Page	2301.5
Issue	A

SPECIAL MATERIALS & OPTIONS SELECTION GUIDELINES

For High Viscosities – Above 2,500 SSU (550 cSt)

- Steel fitted construction recommended above the following viscosities, according to pump size:

Viscosity	Pump Size											
	H	HL	K	KK	L	LL	LS	Q	QS	N	R	RS
SSU	25,000	7,500	25,000	75,000	25,000	2,500	75,000	7,500	75,000	75,000	25,000	75,000
cSt	5,500	1,700	5,500	17,000	5,500	550	17,000	1,700	17,000	17,000	5,500	17,000

- Extra clearances, depending on viscosity. See ES-2 for recommendations.
- Special Sealing:
FKM or Buna N Type 1 component seals good up to 15,000 SSU (3,300 cSt).
PTFE Type 9 seals good up to 25,000 SSU (5,500 cSt).
Packed gland good up to 2,000,000 SSU (440,000 cSt).
Cartridge triple lip seals available to 2,000,000 SSU (440,000 cSt).
- Larger ports may be required depending on suction conditions.
- Pump should be operated at slower than normal speeds, which may require a larger pump.
- Internal circulation holes in the ProPort casing can be used to promote flow behind the rotor.
- For viscosities over 250,000 SSU (55,000 cSt), contact factory for additional pump construction and operation recommendations.

For Low Viscosities or Non-Lubricating Liquids – Below 100 SSU (20 cSt)

- Carbon graphite bushings.
- Pump should be operated at slower than normal speeds, which may require a larger pump.

For High Temperatures – Above 225°F (105°C)

- High temperature elastomers – FKM up to 350°F (175°C); Buna up to 225°F (105°C); PTFE up to 450°F (230°C);
- High temperature bushings recommended depending on temperature, size and specific material.
See ESB-3 for recommendations.
- Additional operating clearances may be required depending on temperature, size and specific material.
See ES-2 for recommendations.
- For temperatures above 450°F (230°C), special materials and sealing requirements may be needed.
Contact factory for recommendations.
- Pump should be operated at slower than normal speeds, which may require a larger pump.

For Abrasive or Dirty Liquids

- If possible, filter or strain out the abrasives present.
- Wear resistant bushings - hardened cast iron, tungsten carbide or Colmonoy coated.
- Abrasive-resistant idler pin - tungsten carbide or Colmonoy plus TC filler coated pins.
- Hardened or hard-coated shaft.
- Abrasive-resistant seals.
- For high concentrations of abrasives or particle sizes greater than 250 microns (0.010 in), contact factory for recommendations.
- Pump should be operated at slower than normal speeds, which may require a larger pump.
- Consult factory for specific recommendations.

Section	2301
Page	2301.6
Issue	A

UNIVERSAL PRODUCT LINE: STEEL EXTERNALS — NON-JACKETED PUMPS

123C Series™, 4123C Series™, 323A Series™, 4323A Series™

SPECIFICATIONS

Model Number	③ Standard Port Size	Nominal Pump Rating (100 SSU & below)			④ Maximum Hydrostatic Pressure		① Maximum Discharge Pressure for 100 SSU liquid at rated speed		② Maximum Recommended Temperature for Standard Pump		Approx. Shipping Weight with Valve	
	Inches	GPM	m ³ /h	RPM	PSIG	BAR	PSIG	BAR	°F	°C	Lbs.	Kg.
H123C	1 ½	15	3	1750	400	28	200	14	450	230	50	23
H4123C	1 ½	15	3	1750	400	28	200	14	350	175	50	23
HL123C	1 ½	30	7	1750	400	28	200	14	450	230	50	23
HL4123C	1 ½	30	7	1750	400	28	200	14	350	175	50	23
K123C	2	80	18	780	400	28	200	14	450	230	132	60
K4123C	2	80	18	780	400	28	200	14	350	175	132	60
KK123C	2	100	23	780	400	28	200	14	450	230	132	60
KK4123C	2	100	23	780	400	28	200	14	350	175	132	60
L123C	2 ½	135	31	640	400	28	200	14	450	230	221	100
L4123C	2 ½	135	31	640	400	28	200	14	350	175	221	100
LL123C	3	140	32	520	400	28	200	14	450	230	234	106
LL4123C	3	140	32	520	400	28	200	14	350	175	234	106
LS123C	3	200	45	640	400	28	200	14	450	230	250	114
LS4123C	3	200	45	640	400	28	200	14	350	175	250	114
Q123C	4	300	68	520	250	17	200	14	450	230	491	223
Q4123C	4	300	68	520	250	17	200	14	350	175	491	223
QS123C	6	500	114	520	250	17	200	14	450	230	571	259
QS4123C	6	500	114	520	250	17	200	14	350	175	571	259
N323A	6	600	136	350	250	17	200	14	450	230	1,000	453
N4323A	6	600	136	350	250	17	200	14	350	175	1,000	453
R323A	8	1,100	250	280	250	17	200	14	450	230	1,435	651
R4323A	8	1,100	250	280	250	17	200	14	350	175	1,435	651
RS323A	10	1,600	364	280	250	17	125	9	450	230	2,500	1,140
RS4323A	10	1,600	364	280	250	17	125	9	350	175	2,500	1,140

① For maximum recommended discharge pressures at different viscosities, see performance curves, which can be electronically generated with the Viking Pump Curve Generator, located on www.vikingpump.com. If suction pressure exceeds 50 PSIG, consult factory. Higher pressures possible with factory approval based on application details.

② Extra clearances are required above 225°F / 105°C. Higher temperatures can be handled with special construction, consult factory.

③ Ports are suitable for Class 150 ANSI steel or stainless steel companion flanges or flanged fittings.

④ Maximum hydrostatic pressure for standard pump construction. Rating is dependent on seal, gaskets and ports.

**UNIVERSAL PRODUCT LINE:
STEEL EXTERNALS — NON-JACKETED PUMPS**

123C Series™, 4123C Series™, 323A Series™, 4323A Series™

Section	2301
Page	2301.7
Issue	A

PORT OPTIONS FOR PROPORT™ CASING

Port Options	Pump Sizes								
	H	HL	K	KK	L	LL	LS	Q	QS
1.5" Class 150 ①	S®	S®							
1.5" Class 300 ②	✓®	✓®							
2" Class 150 ①	✓	✓	S®	S®					
2" Class 300 ②	✓	✓	✓®	✓®					
2.5" Class 150 ①			✓®	✓®	S®				
2.5" Class 300 ②			✓®	✓®	✓®				
3" Class 150 ①			✓	✓	✓®	S®	S®		
3" Class 300 ②			✓	✓	✓	✓®	✓®		
4" Class 150 ①			✓®	✓®	✓	✓	✓	S®	
4" Class 300 ②					✓	✓	✓	✓®	
6" Class 150 ①									S®
6" Class 300 ②									✓®
DIN 32 PN16 *	✓®	✓®							
DIN 40 PN16 *	✓	✓							
DIN 50 PN16 *	✓	✓	✓®	✓®					
DIN 65 PN16 *			✓	✓	✓	✓®			
DIN 80 PN16 *			✓	✓	✓	✓®	✓®		
DIN 100 PN16 *					✓	✓	✓	✓®	✓®
DIN 150 PN16 *								✓	✓®

✓ = Available Port Option

S = Standard Porting

® = Flanges Designed with a Raised Face

① = Ports are suitable for use with Class 150 steel or stainless steel companion flanges or flanged fittings

② = Ports are suitable for use with Class 300 steel or stainless steel companion flanges or flanged fittings

* Ports are suitable for use with DIN PN16 steel or stainless steel companion flanges or flanged fittings

Section	2301
Page	2301.8
Issue	A

UNIVERSAL PRODUCT LINE: STEEL EXTERNALS — NON-JACKETED PUMPS

123C Series™, 4123C Series™, 323A Series™, 4323A Series™

DIMENSIONS – H THROUGH Q SIZES

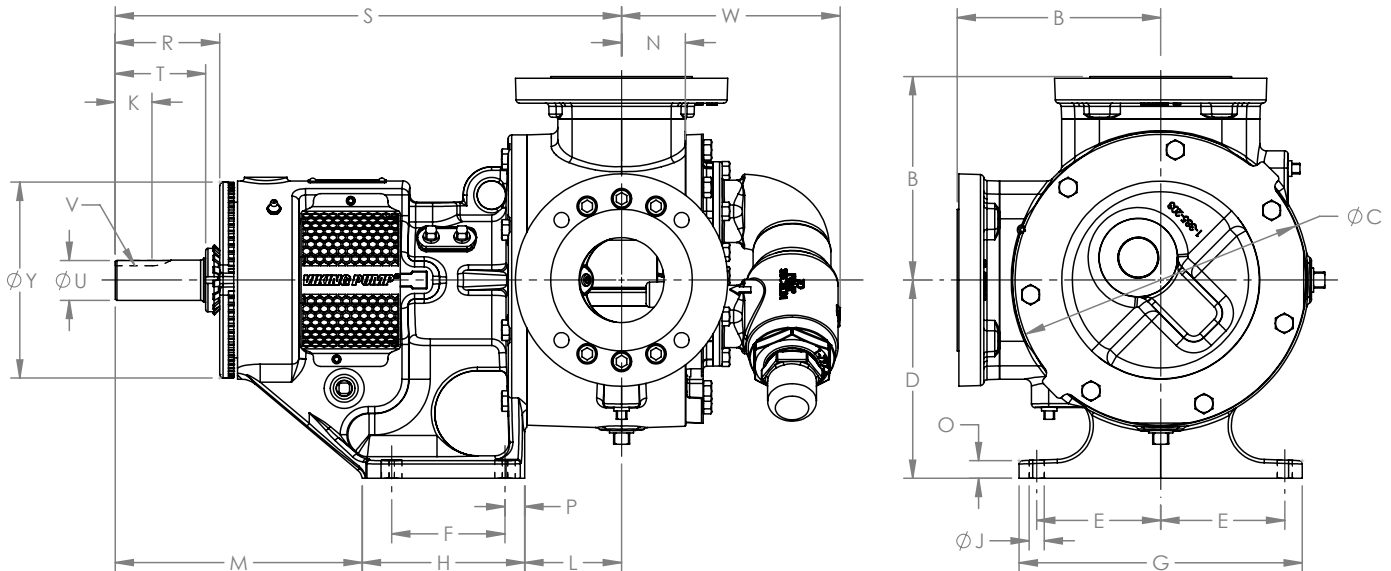

These dimensions are average and not for construction purposes. Certified prints on request.

Model Number		① A (in)		B	C	D	E	② ③ F	G	H	J	K	L	M
Packed	Mechanical Seal													
H123C	H4123C	1.5	in	3.50	4.75	3.50	2.75	2.25	6.75	3.50	0.47	0.99	3.38	5.19
HL123C	HL4123C		mm	89	121	89	70	57	171	89	12	25	86	132
K123C	K4123C	2	in	5.25	8.00	5.50	4.00	2.75	9.25	4.00	0.53	1.42	3.00	9.38
KK123C	KK4123C		mm	133	203	140	102	70	235	102	13	36	76	238
L123C	L4123C	2.5	in	7.19	10.25	7.00	4.38	4.00	10.00	5.38	0.53	2.25	3.58	8.89
LL123C	LL4123C		mm	183	260	178	111	102	254	137	13	57	91	226
LS123C	LS4123C	3	in	7.19	10.25	7.00	4.38	4.00	10.00	5.38	0.53	2.25	3.58	8.89
LS123C	LS4123C		mm	183	260	178	111	102	254	137	13	57	91	226
Q123C	Q4123C	4	in	8.25	14.00	8.75	4.12	4.00	10.00	6.00	0.69	3.58	6.62	11.12
Q123C	Q4123C		mm	210	356	222	105	102	254	152	18	91	168	282

Model Number			N	O	② ③ P	R	S	T	U (in)	V (in)	W	Y
Packed	Mechanical Seal											
H123C	H4123C	in	1.19	0.56	0.62	2.20	12.06	1.62	0.75	.19 x .09	4.04	5.75
HL123C	HL4123C	mm	30	14	16	56	306	41			103	146
K123C	K4123C	in	1.75	0.62	0.62	2.84	16.38	2.25	1.12	.25 x .12	7.00	6.75
KK123C	KK4123C	mm	44	16	16	72	416	57			178	171
L123C	L4123C	in	1.75	0.62	0.62	3.70	17.87	3.13	1.44	.38 x .19	7.18	7.00
LL123C	LL4123C	mm	44	16	16	94	454	80			182	178
LL123C	LL4123C	in	2.25	0.62	0.62	3.70	17.87	3.13	1.44	.38 x .19	7.68	7.00
LL123C	LL4123C	mm	57	16	16	94	454	80			195	178
LS123C	LS4123C	in	2.44	0.62	0.62	3.90	19.25	3.50	1.44	.38 x .19	7.72	7.00
LS123C	LS4123C	mm	62	16	16	99	489	89			196	178
Q123C	Q4123C	in	3.00	0.75	1.00	5.20	23.75	4.50	1.94	.50 x .25	11.25	8.38
Q123C	Q4123C	mm	76	19	25	132	603	114			286	213

① Unless otherwise noted, ports are suitable for class 150 ANSI stainless steel companion flanges or flanged fittings.

② H/HL bracket foot has slotted foot mounting holes. Dimension F = 1.65-2.38 [42-60] and dimension P = 0.52-0.65 [13-16].

③ L/LL/LS bracket foot has slotted foot mounting holes. Dimension F = 3.81-4.19 [81-106] and dimension P = 0.45-0.64 [12-16].

UNIVERSAL PRODUCT LINE: STEEL EXTERNALS — NON-JACKETED PUMPS

123C Series™, 4123C Series™, 323A Series™, 4323A Series™

Section	2301
Page	2301.9
Issue	A

DIMENSIONS — QS SIZE

Dimensions shown in inches with millimeter equivalent shown in parentheses

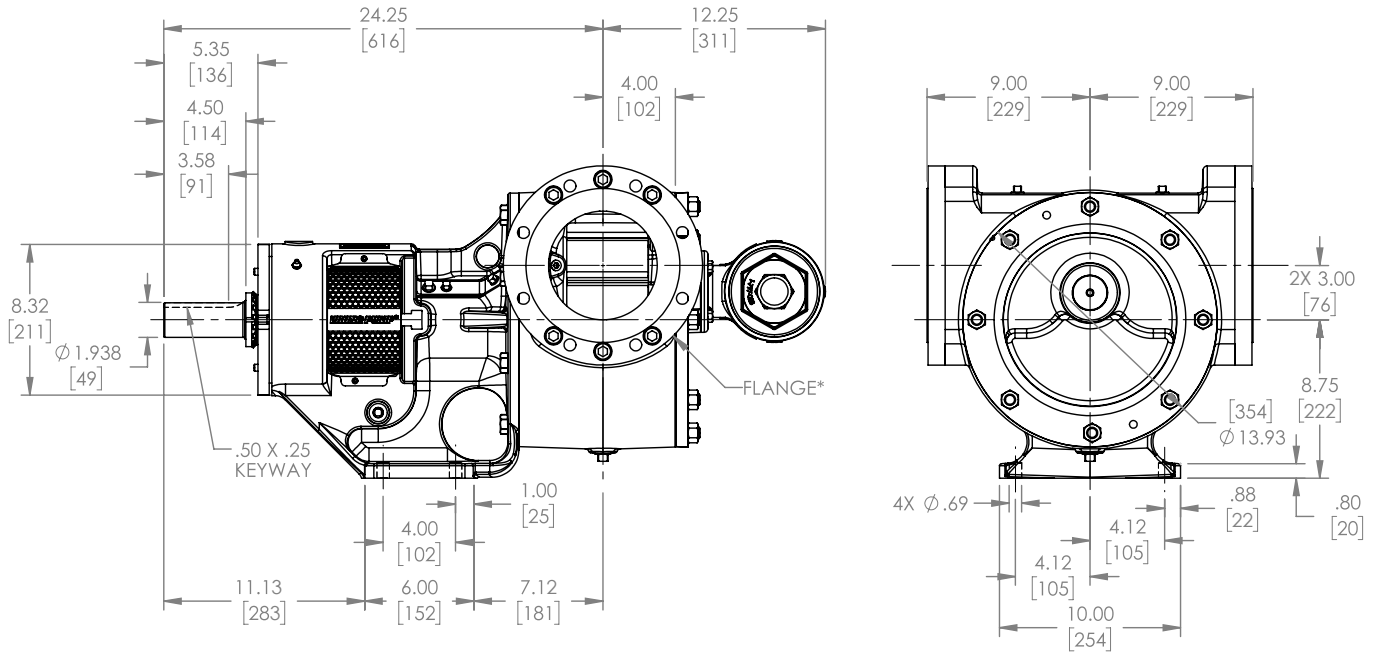

* 123C Series™ / 4123C Series™ ports suitable for use with Class 150 ANSI steel or stainless steel companion flanges or flanged fittings. Ports are tapped for installation of studs.

Section	2301
Page	2301.10
Issue	A

UNIVERSAL PRODUCT LINE: STEEL EXTERNALS — NON-JACKETED PUMPS

123C Series™, 4123C Series™, 323A Series™, 4323A Series™

DIMENSIONS – N & R SIZES – JACKETED BRACKET (323A SERIES™, 4323A SERIES™)

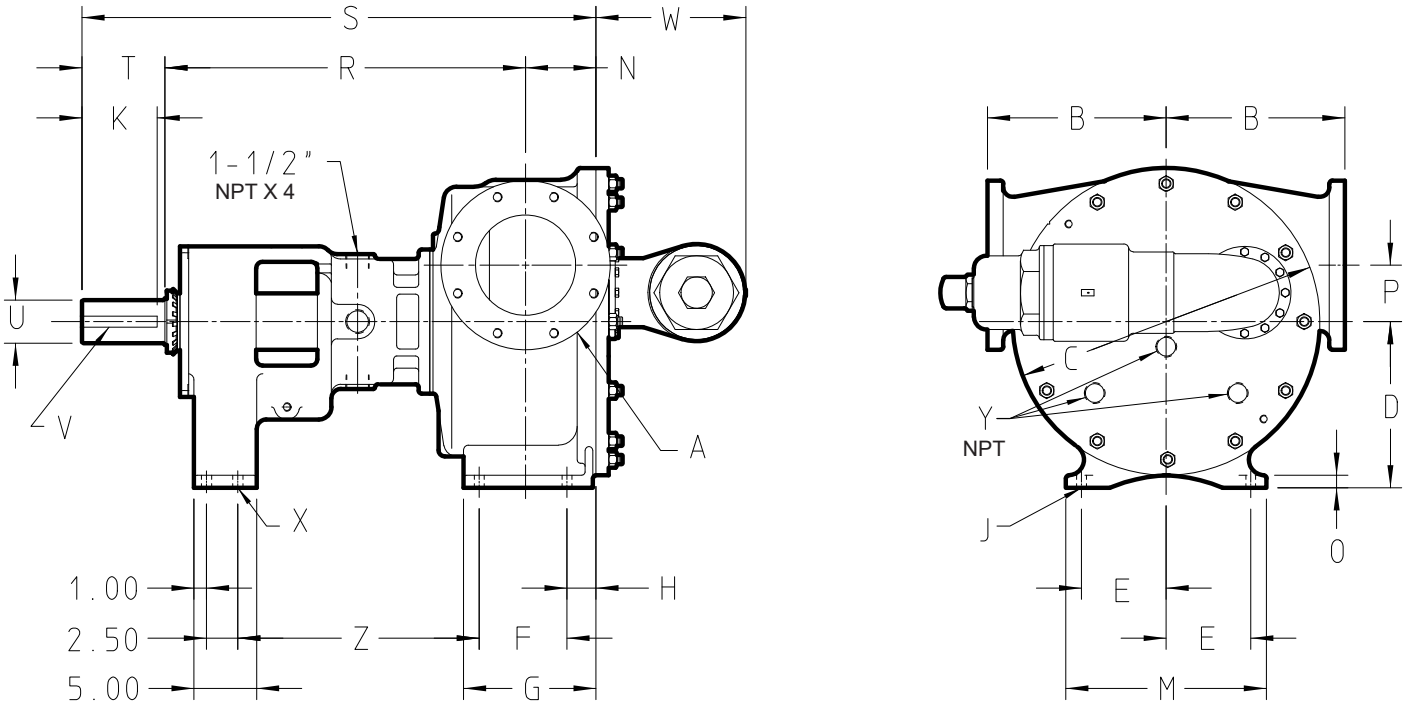

Model Number		A	B	C	D	E	F	G	H	J	K	M	N	O	P	R	S	T	U	V	W	X	Y	Z	
Packed	Stuffing Box Seal	(in)																(in)	(in)			(in)			
N323A	N4323A	①	in	9.75	17.25	9.50	5.00	6.25	8.69	1.62	0.69	4.50	12.00	4.50	1.00	3.00	26.00	36.50	6.00	2.44	.62	8.63	0.69	—	18.94
		6	mm	248	438	241	127	159	221	41	18	114	305	114	25	76	660	927	152	x.31	219	18	—	481	
R323A	R4323A	①	in	14.25	24.50	13.25	6.75	7.00	10.56	2.31	0.78	6.00	16.00	5.62	1.00	4.50	28.75	41.00	6.62	3.44	.88	12.00	0.69	1.25	19.25
		8	mm	362	622	337	171	178	268	59	20	152	406	143	25	114	730	1041	168	x.44	305	18	1.25	489	

① Ports are suitable for use with Class 150 ANSI steel or stainless steel companion flanges or flanged fittings. Ports are tapped for installation of studs.

NOTE: The N size is standard with a jacketed bracket and non-jacketed head and non-jacketed relief valve, while the “R” size is standard with a jacketed bracket, a jacketed head, and a non-jacketed relief valve.

**UNIVERSAL PRODUCT LINE:
STEEL EXTERNALS — NON-JACKETED PUMPS**

123C Series™, 4123C Series™, 323A Series™, 4323A Series™

Section	2301
Page	2301.11
Issue	A

**DIMENSIONS – RS SIZE – JACKETED BRACKET
(323A SERIES™, 4323A SERIES™)**

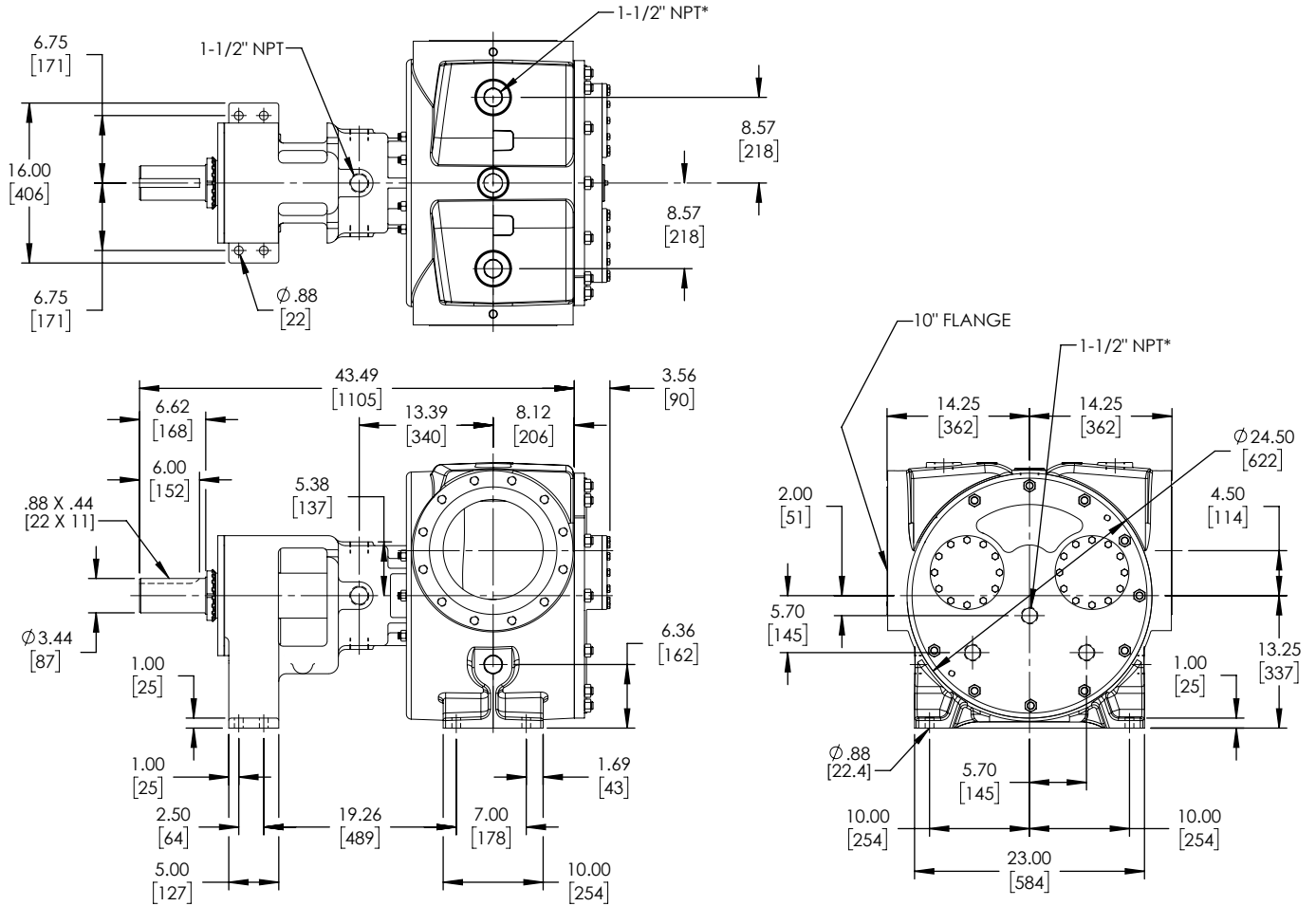

NOTE: RS size pumps are only available with a jacketed casing, as shown. RS pumps are standard with raised face flanged ports.

Section	2301
Page	2301.12
Issue	A

**UNIVERSAL PRODUCT LINE:
STEEL EXTERNALS — NON-JACKETED PUMPS**
123C Series™, 4123C Series™, 323A Series™, 4323A Series™

NPSH REQUIRED

Printed performance curves are not available.

Performance curves can be electronically generated with the Viking Pump Curve Generator on vikingpump.com.

NPSH (Net Positive Suction Head): The $NPSH_R$ (Net Positive Suction Head Required by the pump) is given in the table below and applies for viscosities through 750 SSU. $NPSH_A$ (Net Positive Suction Head – Available in the system) must be greater than the $NPSH_R$. For a complete explanation of NPSH, see Application Data Sheet AD-19.

FOR VISCOSITIES UP TO 750 SSU – See $NPSH_R$ table below.

$NPSH_R$ for high viscosities can be estimated using the following method:

1. Calculate line loss for a 1 foot long pipe of a diameter matching the pump inlet port size. Use your flow rate and max viscosity.
2. Convert this value into Feet of Liquid (S.G. 1.0)
3. Add this value to the $NPSH_R$ value in the chart below.

$NPSH_R$ – FEET OF LIQUID (Specific Gravity 1.0), Viscosities up to 750 SSU

PUMP SIZE	PUMPS SPEED, RPM														
	100	125	155	190	230	280	350	420	520	640	780	950	1150	1450	1750
H, HL	—	—	—	—	1.7	1.8	1.9	2.1	2.4	2.8	3.4	4.5	6.2	9.5	13.5
K, KK	—	1.7	1.8	1.9	2.1	2.3	2.8	3.3	4.4	6.3	9.1	—	—	—	—
L	1.6	1.8	2.0	2.2	2.5	3.0	3.8	5.0	7.3	10.8	—	—	—	—	—
LL	1.6	1.8	2.0	2.2	2.5	3.0	3.8	5.0	7.3	—	—	—	—	—	—
LS	1.6	1.8	2.0	2.2	2.5	3.0	3.8	5.0	7.3	10.8	—	—	—	—	—
Q, QS	1.9	2.1	2.3	2.7	3.3	4.2	6.1	8.4	12.7	—	—	—	—	—	—
N	2.1	2.3	3.5	4.5	6.3	9.5	15.0	—	—	—	—	—	—	—	—
R	6.1	7.1	8.3	10.1	12.1	15.2	—	—	—	—	—	—	—	—	—
RS	7.0	8.5	10.4	13.1	17.2	22.4	—	—	—	—	—	—	—	—	—