

**TECHNICAL SERVICE MANUAL: INSTALLATION, OPERATION & MAINTENANCE**



LIQUID SPECIFIC PRODUCT LINE: CAST IRON  
 32E SERIES™ & SINGLE CHANNEL CONTROLLER  
 SIZES: LQ, Q, M, N

TSM	1466
Page	1 of 27
Issue	A

**TABLE OF CONTENTS**

Model Number Chart.....1  
 Introduction .....1  
 Safety Information & Instructions.....2  
 Controller Safety Information & Instructions.....3  
 Special Information .....4  
     *Rotation* .....4  
     *Pressure Relief Valves*.....4  
 Maintenance.....4  
     *Lubrication*.....4  
     *Packing Adjustment*.....4  
     *Cleaning Pump*.....4  
     *Storage*.....4  
     *Suggested Repair Tools*.....4  
 Pump Disassembly .....6  
 Pump Assembly .....6  
 Installation: Carbon Graphite Bushings.....7  
 Pressure Relief Valve Instructions.....7  
     *Disassembly*.....7  
 Installation: Heat Cartridges.....8  
     *Assembly*.....8  
     *Pressure Adjustment*.....8  
     *Important Ordering Information*.....8  
     *Notes*.....9  
 Single Channel Controller.....10  
     *Dimensions: Controller*.....10  
     *Dimensions: Relay (N Size Only)*.....11  
     *Installation: Controller*.....11  
     *Removing the Mounted Controller from Its Case*.....12  
     *Returning the Controller to Its Case*.....12  
     *Relay (N Size Only)*.....12  
     *Wiring*.....13  
     *Notes*.....15  
     *Key Layout & Functions*.....15  
     *Operation*.....16  
     *Troubleshooting*.....16  
     *Technical Data - Controller*.....17  
     *Technical Data - Relay*.....17

*EU (European Union) Specifications*.....18  
*Dismantling & Disposal*.....18  
 APPENDIX (Formerly TSM 000).....18  
 General Installation Notes.....18  
 Foundation .....20  
 Component & Unit Lifting Features .....20  
 Alignment .....21  
 Piping .....22  
 Start Up .....23  
 Troubleshooting .....23  
     *Vacuum Gauge - Suction Port*.....23  
     *Pressure Gauge - Discharge Port*.....24  
 Rapid Wear .....25  
 Preventative Maintenance .....25  
 Do's & Don'ts .....26  
     *Installation*.....26  
     *Operation*.....26  
     *Maintenance*.....26

**MODEL NUMBER CHART**

	Packed
	LQ32E
	Q32E
	M32E
	N32E

**INTRODUCTION**

*The illustrations used in this manual are for identification purposes only and cannot be used for ordering parts.* Obtain a parts list from your Viking Pump® representative. Always give a complete name of part, part number and material with the model number and serial number of pump when ordering repair parts. The unmounted pump or pump unit model number and serial number are on the nameplate. This manual only applies to the pump models specified in the "Model Number Chart" on page 1. Pump specifications and recommendations are listed in the Catalog Sections, which are available at vikingpump.com.

FIGURE 1: N32E



FIGURE 2: SINGLE CHANNEL CONTROLLER



# SAFETY INFORMATION & INSTRUCTIONS

IMPROPER INSTALLATION, OPERATION OR MAINTENANCE OF PUMP MAY CAUSE SERIOUS INJURY OR DEATH, AND/OR RESULT IN DAMAGE TO PUMP AND/OR OTHER EQUIPMENT. VIKING'S WARRANTY DOES NOT COVER FAILURE DUE TO IMPROPER INSTALLATION, OPERATION OR MAINTENANCE.

THIS INFORMATION MUST BE FULLY READ BEFORE BEGINNING INSTALLATION, OPERATION OR MAINTENANCE OF PUMP, AND MUST BE KEPT WITH PUMP. PUMP MUST BE INSTALLED, OPERATED AND MAINTAINED ONLY BY SUITABLY TRAINED AND QUALIFIED PERSONS.

THE FOLLOWING SAFETY INSTRUCTIONS MUST BE FOLLOWED AND ADHERED TO AT ALL TIMES.

 **DANGER** = FAILURE TO FOLLOW THE INDICATED INSTRUCTION MAY RESULT IN SERIOUS INJURY OR DEATH.

 **WARNING** = IN ADDITION TO SERIOUS INJURY OR DEATH, FAILURE TO FOLLOW THE INDICATED INSTRUCTION MAY CAUSE DAMAGE TO PUMP AND/OR OTHER EQUIPMENT

## DANGER

**BEFORE** opening any liquid chamber (pumping chamber, reservoir, relief valve adjusting cap fitting, etc.) be sure that:

- Any pressure in the chamber has been completely vented through the suction or discharge lines or other appropriate openings or connections.
- The pump drive system (motor, turbine, engine, etc.) has been "locked out" or otherwise been made non-operational, so that it cannot be started while work is being done on the pump.
- You know what material the pump has been handling, have obtained a material safety data sheet (MSDS) for the material, and understand and follow all precautions appropriate for the safe handling of the material.

## DANGER

**BEFORE** operating the pump, be sure all drive guards are in place.

## DANGER

**DO NOT** operate pump if the suction or discharge piping is not connected.

## DANGER

**DO NOT** place fingers into the pumping chamber, or its connection ports, or into any part of the drive train if there is any possibility of the pump shaft being rotated.

## WARNING

**DO NOT** exceed the pumps rated pressure, speed, and temperature, or change the system/duty parameters from those the pump was originally supplied, without confirming its suitability for the new service.

## WARNING

**BEFORE** operating the pump, be sure that:

- It is clean and free from debris.
- All valves in the suction and discharge pipelines are fully opened.
- All piping connected to the pump is fully supported and correctly aligned with the pump.
- Pump rotation is correct for the desired direction of flow.

## WARNING

**INSTALL** pressure gauges/sensors next to the pump suction and discharge connections to monitor pressures.

## WARNING

**USE** extreme caution when lifting the pump. Suitable lifting devices should be used when appropriate. Lifting eyes installed on the pump must be used **only** to lift the pump, not the pump with drive and/or base plate. If the pump is mounted on a base plate, the base plate must be used for all lifting purposes. If slings are used for lifting, they must be safely and securely attached. For weight of the pump alone (which does not include the drive and/or base plate) refer to the Viking Pump® product catalog.

## DANGER

**DO NOT** attempt to dismantle a pressure relief valve that has not had the spring pressure relieved or is mounted on a pump that is operating.

## DANGER

**AVOID** contact with hot areas of the pump and/or drive. Certain operating conditions, temperature control devices (jackets, heat-tracing, etc.), improper installation, improper operation, and improper maintenance can all cause high temperatures on the pump and/or drive.

## WARNING

**THE PUMP** must be provided with pressure protection. This may be provided through a relief valve mounted directly on the pump, an in-line pressure relief valve, a torque limiting device, or a rupture disk. If pump rotation may be reversed during operation, pressure protection must be provided on both sides of pump. Relief valve adjusting screw caps must always point towards suction side of the pump. If pump rotation is reversed, position of the relief valve must be changed. Pressure relief valves cannot be used to control pump flow or regulate discharge pressure. For additional information, refer to **Appendix, General Installation Notes**, item 5 on Pressure Protection or contact your Viking Pump® representative for Engineering Service Bulletin ESB-31.

## WARNING

**THE PUMP** must be installed in a manner that allows safe access for routine maintenance and for inspection during operation to check for leakage and monitor pump operation.

# CONTROLLER SAFETY INFORMATION & INSTRUCTIONS

INCORRECT INSTALLATION, OPERATION OR MAINTENANCE OF EQUIPMENT MAY CAUSE SEVERE PERSONAL INJURY OR DEATH AND/OR EQUIPMENT DAMAGE AND MAY INVALIDATE THE WARRANTY.

THIS INFORMATION MUST BE READ FULLY BEFORE BEGINNING INSTALLATION, OPERATION OR MAINTENANCE AND MUST BE KEPT WITH THE CONTROLLER. ALL INSTALLATION AND MAINTENANCE MUST BE UNDERTAKEN BY SUITABLY TRAINED AND QUALIFIED PERSONS ONLY

 **DANGER** = FAILURE TO FOLLOW THE LISTED PRECAUTIONARY MEASURES IDENTIFIED BY THIS SYMBOL MAY RESULT IN SERIOUS INJURY OR DEATH.

 **WARNING** = SAFETY INSTRUCTIONS WHICH SHALL BE CONSIDERED FOR REASONS OF SAFE OPERATION OF THE CONTROLLER AND/OR PROTECTION OF THE CONTROLLER ITSELF ARE MARKED WITH THIS SYMBOL.

## **WARNING**

This equipment is suitable for use in class 1, div. 2, Groups A, B, C, and D or Non-Hazardous locations only. Temperature Code T4A.

## **DANGER**

**EXPLOSION HAZARD.** Substitution of component may impair suitability for class 1, div. 2.

## **DANGER**

**EXPLOSION HAZARD.** Do not disconnect equipment unless power has been switched off or the area is known to be nonhazardous.

## **DANGER**

All electrical power to the controller and controlled circuits must be disconnected before removing the controller from the front panel or disconnecting other wiring.

Failure to follow these instructions may cause an electrical shock and/or sparks that could cause an explosion in class 1 div. 2 hazardous locations.

## **DANGER**

Use National Electric (NEC) or other country-specific standard wiring and safety practices when wiring and connecting this controller to a power source and to electrical sensors or peripheral devices. Failure to do so may result in damage to equipment and property, and/or injury or death.

## **DANGER**

Always disconnect, lockout, and tag out supply circuits prior to installing.

## **DANGER**

The installation must comply with standard and local regulations.

## **DANGER**

All wiring should be done by a licensed electrician to meet local codes.

## **DANGER**

Study this manual thoroughly before installing and using the controller.

## **DANGER**

Pay special attention to this section and the parts marked "WARNING!" or "DANGER".

## **DANGER**

Should questions or uncertainties arise, please contact your Viking Pump® representative.

## SPECIAL INFORMATION

### ROTATION

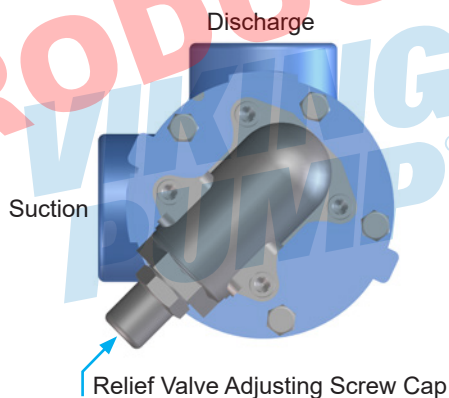
Viking pumps operate equally well in a clockwise or counter-clockwise rotation. Shaft rotation determines which port is suction and which is discharge. Suction port is where pumping elements (gear teeth) come out of mesh

### PRESSURE RELIEF VALVES

1. Viking pumps are positive displacement pumps and must be provided with some sort of pressure protection. This may be a relief valve mounted directly on the pump, an inline pressure relief valve, a torque limiting device or a rupture disk.
2. There are relief valve options available on those pump models designed to accept a relief valve. Options may include a jacketed relief valve or return to tank relief valve.
3. If pump rotation is reversed during operation, pressure protection must be provided on **both** sides of pump.
4. Relief valve adjusting screw cap must **always** point towards suction side of pump, see “**Figure 3**” on page 4. If pump rotation is reversed, remove pressure relief valve and turn end for end.
5. Pressure relief valves cannot be used to control pump flow or regulate discharge pressure.

For additional information on pressure relief valves, refer to **Appendix, General Installation Notes**, item 5 on Pressure Protection or contact your Viking Pump® representative for Engineering Service Bulletin ESB-31.

**FIGURE 3: RELIEF VALVE POSITION**



## MAINTENANCE

These pumps are designed for long, trouble-free service life under a wide variety of application conditions with minimum maintenance. The points listed below will help provide long service life.

### LUBRICATION

External lubrication must be applied slowly with a hand gun to all lubrication fittings every 500 hours of operation with multi-purpose grease, NLGI # 2. Do not over-grease. Contact your Viking Pump® representative with specific lubrication questions or to obtain a copy of Engineering Service Bulletin ESB-515. Applications involving very high or low temperatures will require other types of lubrication.

### PACKING ADJUSTMENT

New packed pumps require initial packing adjustment to control leakage as packing “runs in”. Make initial adjustments carefully and do not over-tighten packing gland. After initial adjustment, inspection will reveal need for packing gland adjustment or packing replacement. Contact your Viking Pump® representative for Engineering Service Bulletin ESB-521 regarding repacking pump.

### CLEANING PUMP

Keep the pump as clean as possible. This will facilitate inspection, adjustment and repair work and help prevent overlooking a dirt covered grease fitting.

### STORAGE

If the pump is to be stored or not used for six months or more, pump must be drained and a light coat of non-detergent SAE 30 weight oil must be applied to all internal pump parts. Lubricate fittings and apply grease to pump shaft extension. Viking suggests rotating pump shaft by hand one complete revolution every 30 days to circulate the oil.

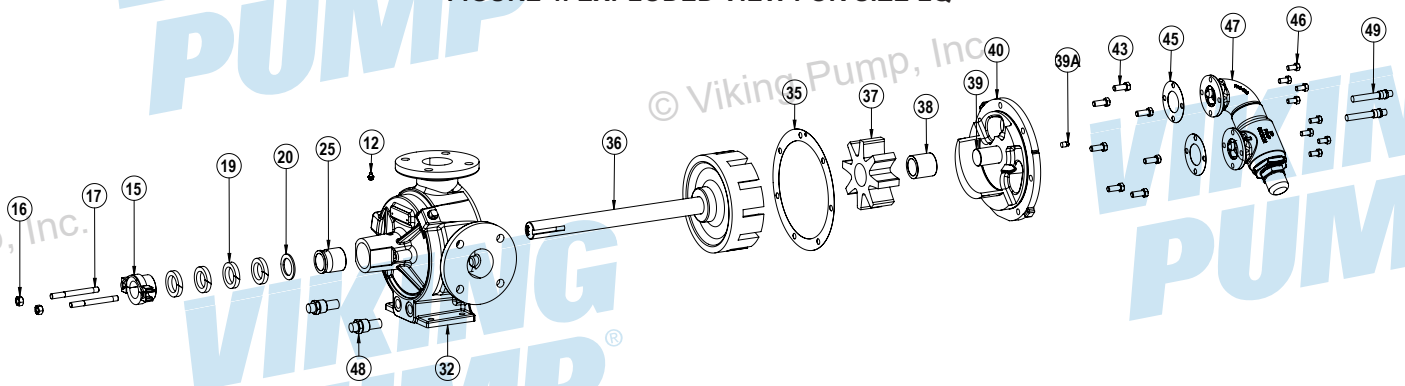
### SUGGESTED REPAIR TOOLS

The following tools must be available to properly repair these pumps. These tools are in addition to standard mechanics' tools such as open-end wrenches, pliers, screwdrivers, etc. Most of the items can be obtained from an industrial supply house.

1. Soft headed hammer
2. Allen wrenches (some mechanical seals and set collars)
3. Packing hooks, flexible (packed pumps)  
2-810-042-999 for 3/8" & larger
4. Brass or plastic bar
5. Arbor press

Contact your Authorized Viking Pump® stocking distributor for available seal and rebuild kits

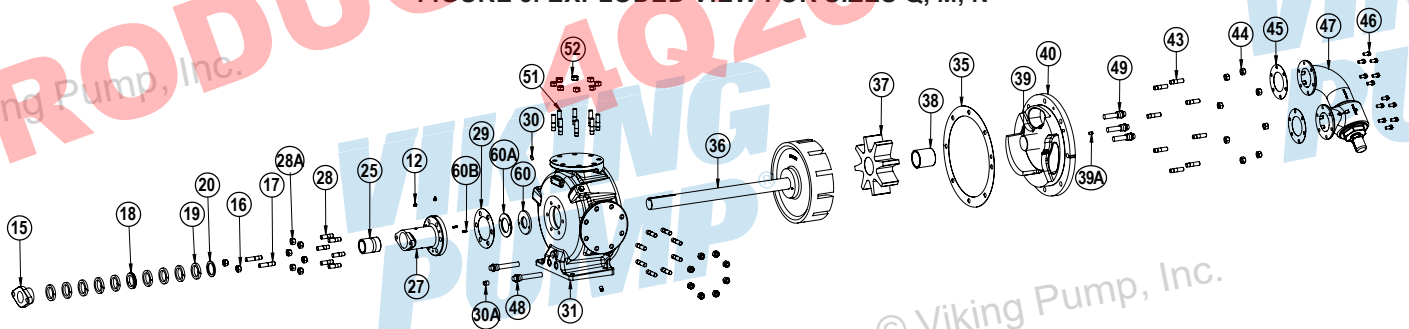
FIGURE 4: EXPLODED VIEW FOR SIZE LQ



Item	Name Of Part	Item	Name Of Part	Item	Name Of Part
12	Grease Fitting	32	Casing and Bushing Assembly	43	Capscrew for Head
15	Packing Gland Kit	35	Head Gasket Set	45	Relief Valve Gasket
16	Packing Gland Nut	36	Rotor and Shaft Assembly	46	Capscrew for Valve
17	Packing Gland Stud	37	Idler and Bushing Assembly	47	Relief Valve
18	Lantern Ring	38	Idler Bushing	48	Heater Cartridges for Casing
19	Packing	39	Idler Pin	49	Heater Cartridges for Head
20	Packing Retainer Washer	39A	Pipe Plug		
25	Casing Bushing	40	Head and Idler Pin Assembly		

Contact your Authorized Viking Pump® stocking distributor for available seal and rebuild kits

FIGURE 5: EXPLODED VIEW FOR SIZES Q, M, N



Item	Name Of Part	Item	Name Of Part	Item	Name Of Part
12	Grease Fitting	30	Pipe Plug	44	Nut for Head
15	Packing Gland	30A	Pipe Plug	45	Relief Valve Gasket
16	Packing Gland Nut	31	Casing	46	Capscrew for Valve
17	Packing Gland Stud	35	Head Gasket Set	47	Relief Valve
18	Lantern Ring	36	Rotor and Shaft Assembly®	48*	Heater Cartridges for Casing
19	Packing	37	Idler and Bushing Assembly	49*	Heater Cartridges for Head
20	Packing Retainer Washer	38	Idler Bushing	51	Stud for Flanges
25	Bushing for Rotor Bearing Sleeve	39	Idler Pin	52	Nut for Flanges
27	Rotor Bearing Sleeve and Bushing	39A	Pipe Plug	60	Rotor Thrust Washer
28	Stud for Rotor Bearing Sleeve	40	Head and Idler Pin Assembly	60A	Rotor Bearing Sleeve Washer
28A	Nut for Rotor Bearing Sleeve	43	Stud for Head	60B	Self Lock Pin
29	Gasket for Rotor Bearing Sleeve				

## DANGER !

Before opening any Viking pump liquid chamber (pumping chamber, reservoir, relief valve adjusting cap fitting, etc.) be sure:

1. That any pressure in the chamber has been completely vented through the suction or discharge lines, or other appropriate openings or connections.
2. That the driving means (motor, turbine, engine, etc.) has been “locked out” or made non-operational, so that it cannot be started while work is being done on pump.
3. That you know what liquid the pump has been handling and the precautions necessary to safely handle the liquid. Obtain a material safety data sheet (MSDS) for the liquid to be sure these precautions are understood.

Failure to follow above listed precautionary measures may result in serious injury or death.

## PUMP DISASSEMBLY

1. Refer to “Figure 4” on page 5 or “Figure 5” on page 5 for name of parts.
2. Mark head and casing before disassembly to ensure proper reassembly. The idler pin, which is offset in pump head, must be positioned toward and equal distance between port connections to allow for proper flow of liquid through pump.
3. Remove the head capscrews.
4. Do not allow idler to fall from idler pin. Tilt top of head back when removing to prevent this. Remove head from pump. Avoid damaging head gasket set, all gaskets are required to maintain end clearance.
5. Remove idler and bushing assembly. If idler bushing needs replacing, refer to “Installation: Carbon Graphite Bushings” on page 7.

Remove the packing gland, packing and packing retainer washer.

## CAUTION !

Older pumps may have snap ring on shaft- remove the snap ring before removing rotor and shaft. Carefully remove the rotor and shaft from the pump to avoid damaging the casing or rotor bearing sleeve bushing.

**THRUST WASHERS:** Rotor thrust washer and rotor bearing sleeve thrust washer used in Q, M and N size pumps should be removed, examined for excessive wear and replaced if necessary. These thrust washers are located on the hub of the rotor and the casing end of rotor bearing sleeve.

If it is necessary to replace the bushing in the casing, rotor bearing sleeve or idler and/or repack the pump, remove the old packing and lantern ring and packing retainer washer. LQ size pumps don't have a lantern ring.

Clean all parts thoroughly and examine for wear and/or damage. Check bushings, and idler pin and replace if necessary. Check all other parts for nicks, burrs, excessive wear and replace if necessary.

## PUMP ASSEMBLY

1. Install bushing into casing or rotor bearing sleeve. If bushing has a lubrication groove, install bushing with groove at 12:00 o'clock position in bracket. If carbon graphite, refer to “Installation: Carbon Graphite Bushings” on page 7.
2. Thrust washers used in Q, M and N size pumps should be assembled on the rotor hub and rotor bearing sleeve. Put the plain washer on the two locating pins on the rotor hub. Put the grooved face washer on the pins on the rotor bearing sleeve with the grooved face toward the rotor.
3. Coat shaft of rotor shaft assembly with non-detergent SAE 30 weight oil. Start end of shaft in bracket bushing turning from right to left, slowly pushing rotor into casing.
4. Place the head gaskets on the head. The proper amount of gaskets should be used to provide the necessary end clearance within the pump so it turns freely with no appreciable end play. “Table 1” on page 6 gives the normal amount of gaskets used on each pump.

TABLE 1: GASKET TABLE

Pump Size	Normal Amount Used	One Set of Gaskets Consists of the Following	Standard End Clearance
LQ	.025" - .030"	1 - .015", 1 - .010", 1 - .006"	.010"
Q	.012" - .030"	2 - .015", 1 - .006"	.015"
M, N	.015" - .036"	2 - .015", 1 - .006"	.020"

5. Coat idler pin with non-detergent SAE 30 weight oil and place idler and bushing on idler pin in head. If replacing carbon graphite bushing, refer to “Installation: Carbon Graphite Bushings” on page 7.
6. The head can now be assembled on the pump. Tilt the top of the head away from the pump slightly until the crescent enters the inside diameter of the rotor and rotate the idler until its teeth mesh with the rotor teeth. Do not damage the head gaskets. Tighten the head capscrews or nuts and then check the end clearance. If the pump shaft cannot be rotated, more gaskets must be added. If, however, the pump has any noticeable end play, remove enough gaskets so the pump has no appreciable end play but still turns freely.
7. Place packing retainer washer in bottom of packing chamber and pack pump with new packing. Use packing suitable for liquid being pumped. Install packing, staggering the joints from one side of shaft to other. Lubricate packing rings with oil, grease or graphite to aid assembly. A length of pipe will help to seat each packing ring.

**NOTE:** If the pump has a lantern ring it must be located below the grease fitting. The grease fitting may be removed to facilitate positioning of the lantern ring.

8. Install packing gland, capscrews and nuts.

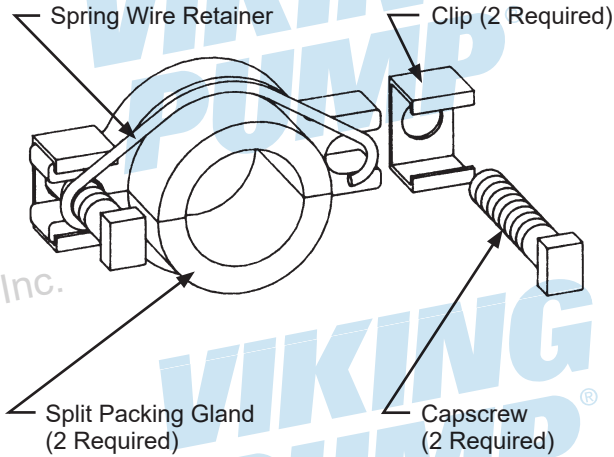
**NOTE:** Pump may be equipped with a 2-piece split packing gland. See “Figure 6” on page 7.

## DANGER !

Before starting pump, be sure all drive equipment guards are in place.

Failure to properly mount guards may result in serious injury or death.

FIGURE 6



## INSTALLATION: CARBON GRAPHITE BUSHINGS

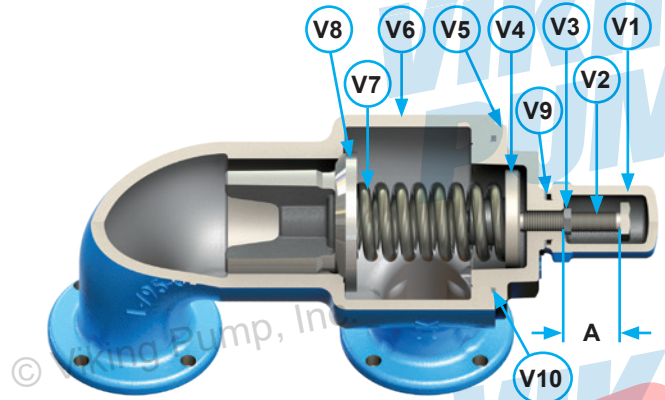
When installing carbon graphite bushings, extreme care must be taken to prevent breaking. Carbon graphite is a brittle material and easily cracked. If cracked, the bushing will quickly disintegrate. Using a lubricant and adding a chamfer on the bushing and the mating part will help in installation. The additional precautions listed below must be followed for proper installation.

1. A press must be used for installation.
2. Be certain bushing is started straight.
3. Do not stop pressing operation until bushing is in proper position. Starting and stopping will result in a cracked bushing.
4. Check bushing for cracks after installation.

## PRESSURE RELIEF VALVE INSTRUCTIONS

FIGURE 7: RELIEF VALVE - ALL SIZES

NOTE: Image is representative only.



VALVE - LIST OF PARTS

V1.	Valve Cap	V6.	Valve Body
V2.	Adjusting Screw	V7.	Valve Spring
V3.	Lock Nut	V8.	Poppet
V4.	Spring Guide	V9.	Cap Gasket
V5.	Bonnet	V10.	Bonnet Gasket*

### **⚠ DANGER !**

Before opening any Viking pump liquid chamber (pumping chamber, reservoir, relief valve adjusting cap fitting, etc.) be sure:

1. That any pressure in the chamber has been completely vented through the suction or discharge lines, or other appropriate openings or connections.
2. That the driving means (motor, turbine, engine, etc.) has been "locked out" or made non-operational, so that it cannot be started while work is being done on pump.
3. That you know what liquid the pump has been handling and the precautions necessary to safely handle the liquid. Obtain a material safety data sheet (MSDS) for the liquid to be sure these precautions are understood.

Failure to follow above listed precautionary measures may result in serious injury or death.

### DISASSEMBLY

Mark valve and head before disassembly to ensure proper reassembly.

1. Remove valve cap.
2. Measure and record length of extension of adjusting screw. Refer to "A" on "Figure 7" on page 7.
3. Loosen locknut and back out adjusting screw until spring pressure is released.
4. Remove bonnet, spring guide, spring and poppet from valve body. Clean and inspect all parts for wear or damage and replace if necessary.

## ASSEMBLY

Reverse procedures outlined under “Disassembly” on page 7. If valve is removed for repairs be sure to replace in same position. Relief valve adjusting screw cap must always point towards suction side of pump.

## PRESSURE ADJUSTMENT

If a new spring is installed or if pressure setting of pressure relief valve is to be changed from that which the factory has set, the following instructions must be carefully followed.

1. Carefully remove valve cap which covers adjusting screw. Loosen locknut which locks adjusting screw so pressure setting will not change during operation of pump.
2. Install a pressure gauge in discharge line for actual adjusting operation.
3. Turn adjusting screw CW (in) to increase pressure and CCW (out) to decrease pressure. For guidance dimensions, contact your Viking Pump® representative for Engineering Standard ES-37.
4. Close the discharge line at a point beyond the pressure gauge. Limit the amount of time the pump is being operated at this condition. The temperature inside the pump will rise rapidly. Gauge will show maximum pressure that valve will allow while pump is in operation.
5. Once pressure is set, tighten locknut and replace cap gasket and valve cap.

## IMPORTANT ORDERING INFORMATION

In ordering parts for pressure relief valve, always give model number and serial number of pump as it appears on nameplate and name of part wanted. When ordering springs, be sure to give pressure setting desired.

## INSTALLATION: HEAT CARTRIDGES

### WARNING !

The pump needs to be properly grounded before the heat cartridges are installed.

1. Spacers should be installed between the foot of the pump and the base. This will create an air gap between the pump and base to limit heat transfer to the base.
2. Coat the threads of the heat cartridge with an anti-seize compound prior to installation. Install heat cartridges into the tapped ports on the head and bracket in the locations shown in “Figure 8” on page 9. “Figure 8” on page 9 also shows the minimum clearance around the pump needed to install and remove the heat cartridges as well as the location for the thermocouple. The number of heaters used and the total wattage for each pump size is given in “Figure 8” on page 9.  $\frac{3}{8}$ ” heat cartridges should be tightened to 10ft-lbs.  $\frac{1}{2}$ ” and  $\frac{3}{4}$ ” heat cartridges should be tightened to 20 ft-lbs.
3. Viking recommends installing a closed loop temperature controller with a control algorithm that will minimize or prevent overshooting the set point temperature. The set point temperature needs to be slightly higher than the melting point and significantly lower than the flash point or boiling point of the liquid being pumped. Viking does offer a controller for use with our heat cartridges. Contact your Viking Pump® representative for details.

### WARNING !

Setting the set point temperature higher than necessary will not make the pump heat any faster and will shorten the life of the heat cartridges.

4. Properly insulate the pump to minimize heat loss. The pump will not heat properly if it is not insulated.

### DANGER !

- Always disconnect, lockout, and tag out supply circuits prior to installing.
- The installation must comply with standard and local regulations.
- Pay special attention to this section and the parts marked “WARNING!” or “DANGER!”.
- All wiring should be done by a licensed electrician to meet local codes. Study this manual thoroughly before installing and using the heat cartridges.
- Should questions or uncertainties arise, please contact your authorized Viking distributor.
- Failure to follow these instructions may cause an electrical shock and/or sparks, which may result in serious injury or death.



## NOTES

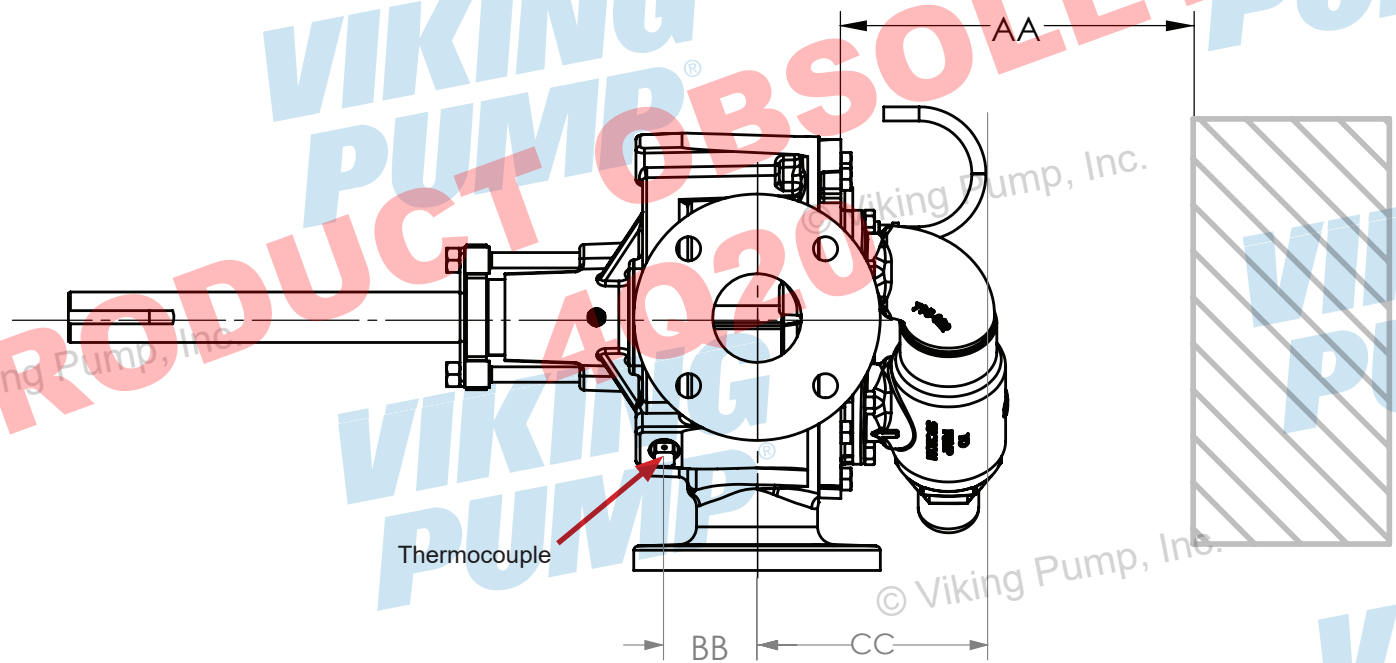
1. Heat cartridges, temperature probes, and controllers must be wired by a licensed electrician to meet local codes.
2. Heat cartridges require 240VAC, 1 Phase, 60 Hz or 220VAC, 1 Phase, 50 Hz power supply.
3. Heat cartridges are UL, CSA, & CE marked, RoHs compliant.
4. Heat cartridges and cables are water resistant but not water proof. They need to be installed in a protected area.
5. To make sure that the liquid within the pump is melted and to avoid damage to the pump, do not start the pump until the set point temperature has been reached.
6. Several factors such as the size of pump, the set point temperature, and the insulation will affect the amount of time it will take for the pump to reach the set point temperature. Typically it will take 3-4 hours for the pump to reach its set point temperature.

7. Do not use heat cartridges with different watt densities from those supplied by Viking. Changing watt densities may result in localized over or under heating.
8. The thermocouple or temperature probe must be installed in the bracket location shown in **“Figure 8”** on page 9. Any other location may result in localized over or under heating.
9. Refer to **“Single Channel Controller”** on page 10 for technical information on the Viking supplied controller for the heat cartridges.
10. The wires for the heat cartridges can be joined together in a junction box, and a single wire from the junction box can be connected to the controller.

## WARNING !

Heat cartridges will be hot. Do not touch pump or heat cartridges until they have been allowed to cool.

**FIGURE 8:**  
HEAT CARTRIDGE DIMENSIONS, LOCATIONS & NUMBER OF HEAT CARTRIDGES IN EACH PUMP MODEL



Pump Size	Temp Probe to Port Center Line (BB)		Head Heater to Port Center Line (CC)		Required to Remove Heater (AA)		Number of Heaters in Head	Number of Heaters in Casing	Total Wattage
	Inch	mm	Inch	mm	Inch	mm			
LQ	2.54	64.5	5.75	146.1	7	177.8	2	2	1200
Q	2.85	72.4	8.25	209.6	9.25	234.95	3	N/A	1500
M	2.64	67.1	8.25	209.6	9.25	234.95	3	2	2250
N	5.05	128.2	8.25	209.6	9.25	234.95	2	2	2500

# SINGLE CHANNEL CONTROLLER

This section describes the installation and operation of the controller. Its function is to set and monitor the heat cartridges for our electrically heated pumps. The controllers are programmed for a specific temperature range. Please see "Table 2" on page 10 for a listing of the available temperature ranges.

**TABLE 2: TEMPERATURE RANGE OPTIONS**

Fahrenheit	Celsius
0 - 150	0 - 65
0 - 250	0 - 120
0 - 350	0 - 175
0 - 450	0 - 230

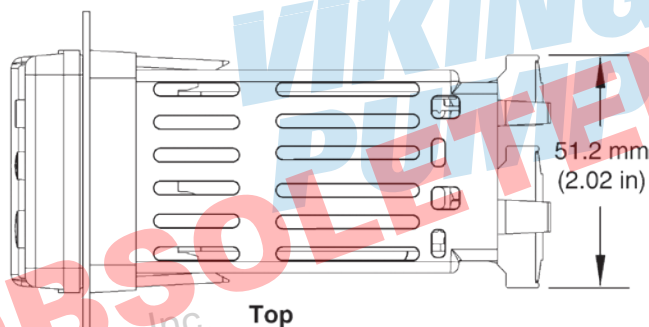
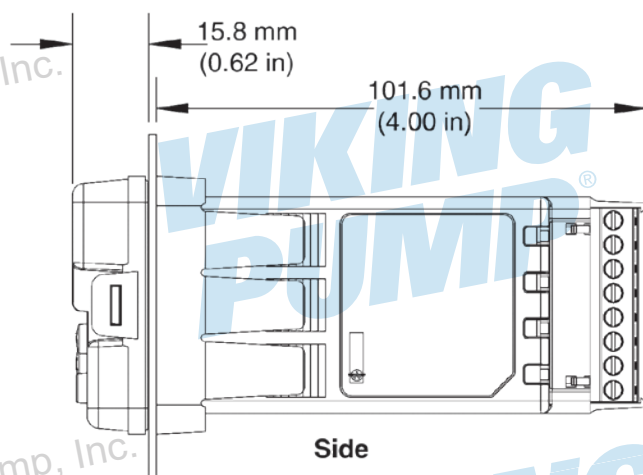
Your shipment should contain the following items:

- Controller (Watlow Model: PM6C2EH-AAAAAAA) (H-QS)
- Controller (Watlow Model: PM6C2EC-AAAAAAA) (N)
- Thermocouple
- Fitting adapter for thermocouple
- CD with Watlow Controller Manual
- 40 amp Relay with N size pump only (Watlow Model: DB10-60C0-0000)

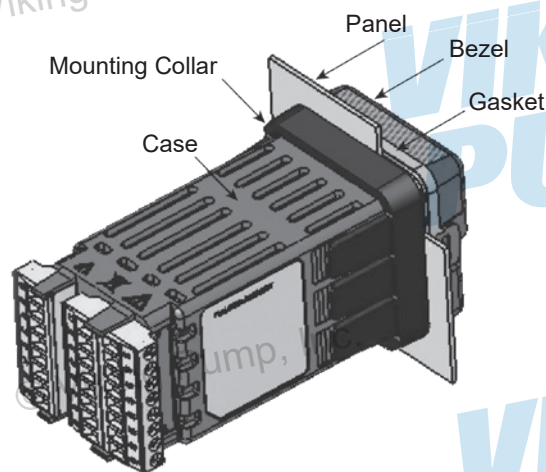
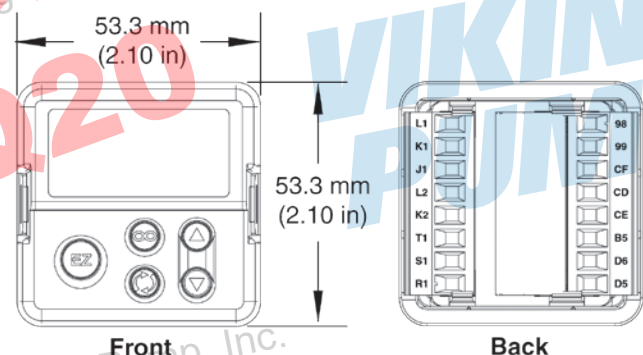
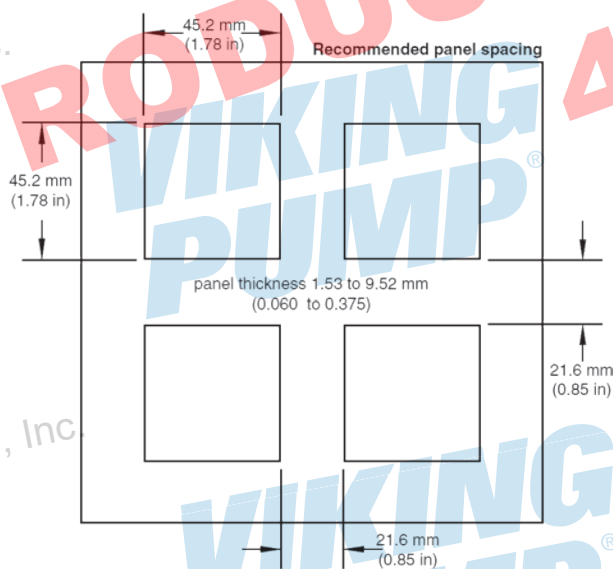
Check carefully that the contents have not been damaged during shipping.

For additional information on the heat cartridges, refer to "Installation: Heat Cartridges" on page 8.

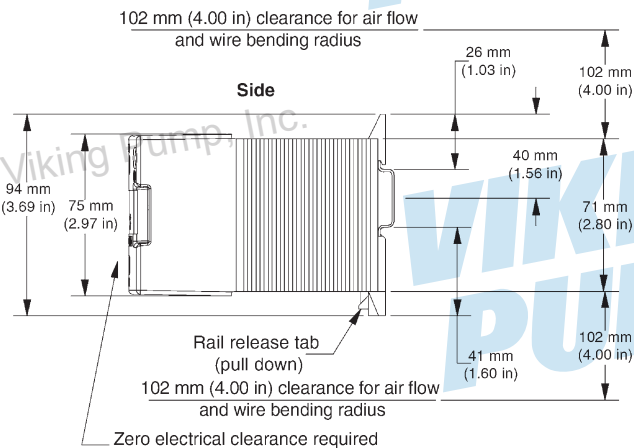
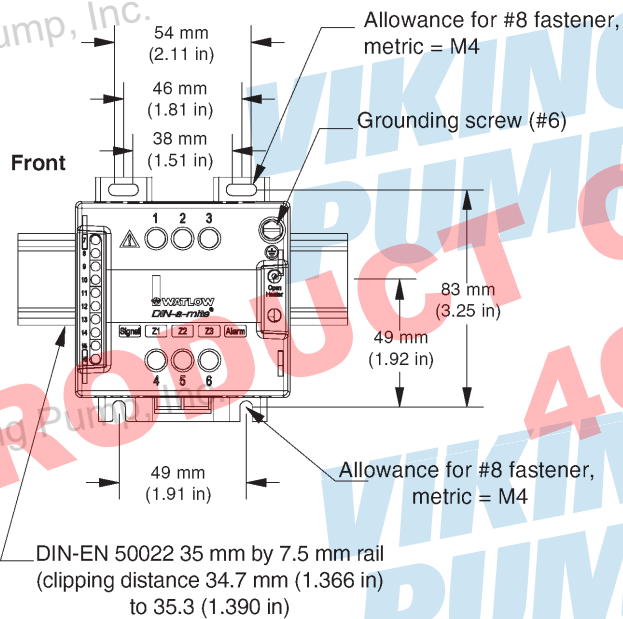
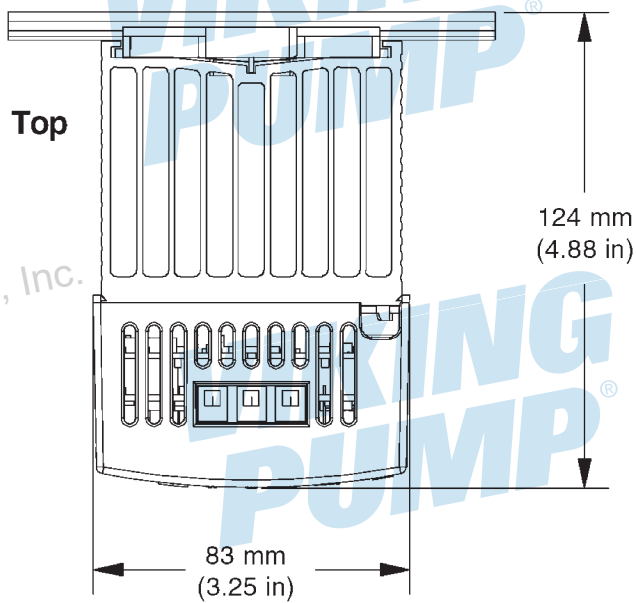
## DIMENSIONS: CONTROLLER



**FIGURE 9: CONTROLLER PANEL LAYOUT**



## DIMENSIONS: RELAY (N SIZE ONLY)



## INSTALLATION: CONTROLLER

### Assembly

1. Make the panel cutout using the mounting template dimensions shown in "Figure 9" on page 10.
2. Insert the case assembly into the panel cutout.
3. While pressing the case assembly firmly against the panel, slide the mounting collar over the back of the controller.

If the installation does not require a NEMA 4X (UL50, IP66) seal, simply slide together until the gasket is compressed.

Slide the mounting collar over the back of the controller:



4. For a NEMA 4X (UL50, IP66) seal, alternately place and push the blade of a screwdriver against each of the four corners of the mounting collar assembly. Apply pressure to the face of the controller while pushing with the screwdriver.

Don't be afraid to apply enough pressure to properly install the controller. The seal system is compressed more by mating the mounting collar tighter to the front panel. If you can move the case assembly back and forth in the cutout, you do not have a proper seal.

The tabs on each side of the mounting collar have teeth that latch into the ridges on the sides of the controller. Each tooth is staggered at a different depth from the front so that only one of the tabs on each side is locked onto the ridge at a time.

**NOTE:** There is a graduated measurement difference between the upper and lower half of the display to the panel. In order to meet the seal requirements mentioned above, ensure that the distance from the front of the top half of the display to the panel is 0.630 in. (16 mm) or less, and the distance from the front of the bottom half and the panel is 0.525 in. (13.3 mm) or less.

## REMOVING THE MOUNTED CONTROLLER FROM ITS CASE

### **⚠ DANGER !**

All electrical power to the controller and controlled circuits must be disconnected before removing the controller from the front panel or disconnecting other wiring.

Failure to follow these instructions may cause an electrical shock and/or sparks that could cause an explosion in class 1 div. 2 hazardous locations.

1. From the face side of the controller, pull out the tabs on each side until you hear it click.

Pull out the tab on each side until you hear it click:



2. Once the sides are released grab the unit above and below the face with two hands and pull the unit out.

Grab the unit above and below the face and pull forward:

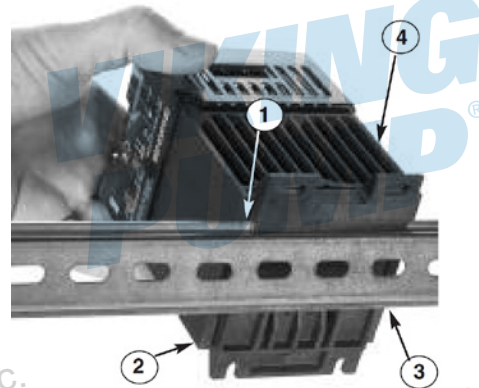


## RETURNING THE CONTROLLER TO ITS CASE

1. Ensure that the orientation of the controller is correct and slide it back into the housing. The controller is keyed so it should slide easily back in to the case. Do not force it. Verify orientation again if it will not slide back into the case
2. Using your thumbs push on either side of the controller until both latches click.

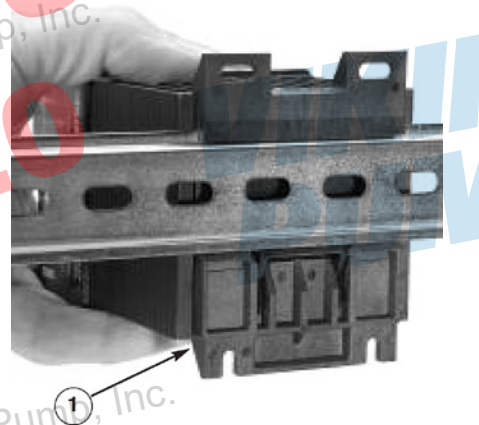
## RELAY (N SIZE ONLY)

### Assembly



1. Push the unit in and down to catch the rail hook on top of the rail.
2. Rotate the bottom of the unit toward the rail.
3. The rail clasp will audibly “snap” into place. If the DIN-A-MITE does not snap into place, check to see if the rail is bent.
4. Mount the cooling fins vertically.

### Disassembly



1. Press down on the release tab while rotating the unit up and away from the rail.

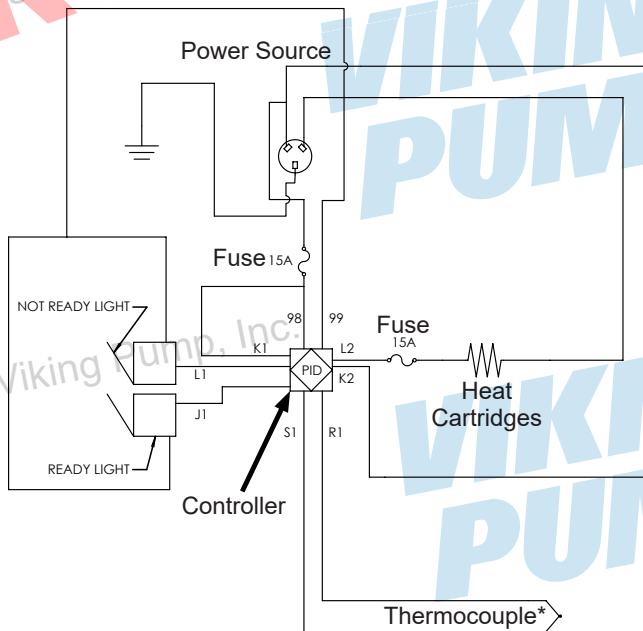
## WIRING

### **⚠ DANGER !**

- Always disconnect, lockout, and tag out supply circuits prior to installing.
- Use National Electric (NEC) or other country-specific standard wiring and safety practices when wiring and connecting this controller to a power source and to electrical sensors or peripheral devices. Failure to do so may result in damage to equipment and property, and/or injury or death.
- The installation must comply with standard and local regulations.
- All wiring should be done by a licensed electrician to meet local codes.
- Study this manual thoroughly before installing and using the controller.
- Pay special attention to this section and the parts marked "WARNING!" or "DANGER".
- Should questions or uncertainties arise, please contact your Viking Pump® representative.
- Proper selection and installation of the thermocouple wiring and cartridge heater wiring is the responsibility of the end user. Refer to the temperature controller manual for instructions.

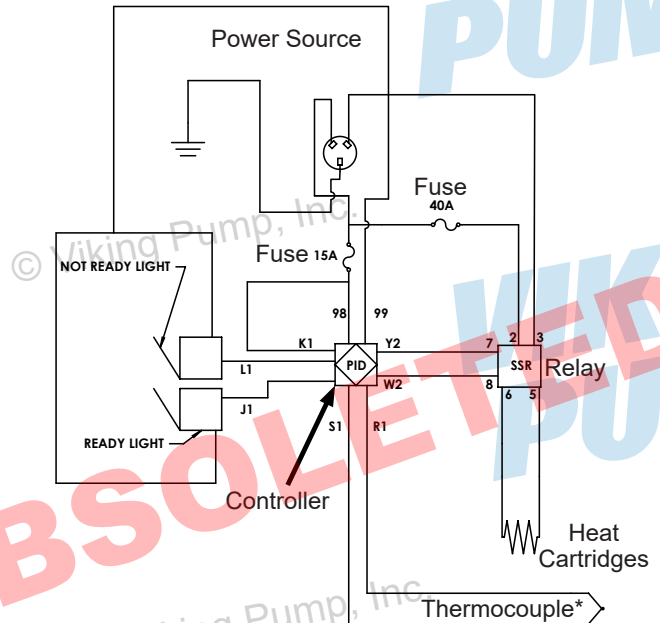
**LQ, Q, M Size Pumps:** "Figure 10" on page 13 shows how the controller is wired to the power source, cartridge heaters, ready light, and thermocouple. "Figure 12" on page 14 shows the layout of the terminals on the controller. The terminal descriptions of the controller are given in "Table 3" on page 14.

**FIGURE 10: WIRING DIAGRAM (LQ, Q, M SIZE PUMPS)**



**N size pumps:** "Figure 11" on page 13 shows how the controller is wired to the power source, cartridge heaters, relay, ready light, and thermocouple. "Figure 13" on page 14 shows the layout of the terminals on the controller, and "Figure 14" on page 14 shows the layout of the terminals on the relay. The terminal descriptions of the controller are given in "Table 4" on page 14, and the relay terminal descriptions are given in "Table 5" on page 14.

**FIGURE 11: WIRING DIAGRAM (N SIZE PUMPS)**



### Notes

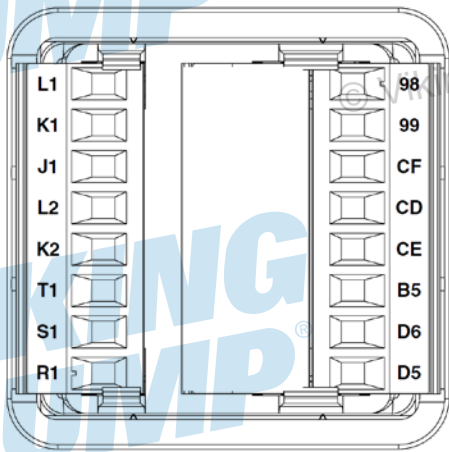
\* Thermocouples are polarity sensitive. The negative lead (usually red) must be connected to S1.

The extension wire for thermocouples must be of the same alloy as the thermocouple.

### **⚠ DANGER !**

Do not put a fuse or switch on the neutral line coming into terminal 3. Failure to follow this guideline could result in personal injury or death.

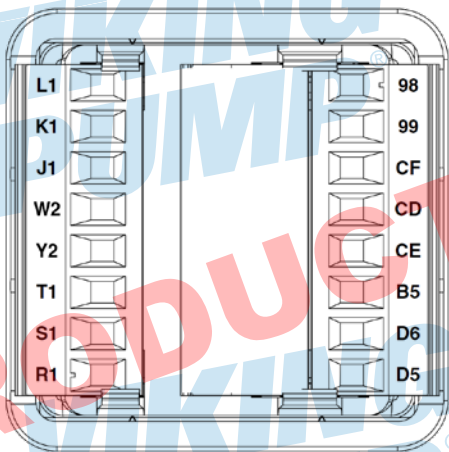
**FIGURE 12: CONTROLLER TERMINAL LOCATIONS (LQ, Q, M SIZE PUMPS)**



**TABLE 3: CONTROLLER TERMINAL DESCRIPTIONS (LQ, Q, M SIZE PUMPS)**

Slot A		Slot C	
L1	Normally Open (Not Ready Light)	98	Power Input; AC; Fused (Controller)
K1	Common (Ready Light / Pump Interlock)	99	Common (Controller)
J1	Normally Closed (Ready Light)	CF	Not Used
L2	Power Output; Fused (Heat Cartridges)	CD	Not Used
K2	Common (Heat Cartridges)	CE	Not Used
T1	Not Used	B5	Not Used
S1	Negative Thermocouple Lead (Usually red wire used)	D6	Not Used
R1	Positive Thermocouple Lead	D5	Not Used

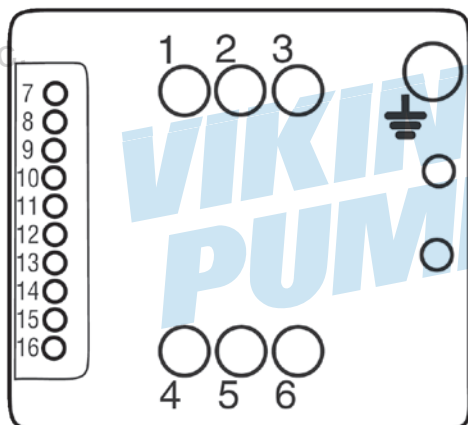
**FIGURE 13: CONTROLLER TERMINAL LOCATIONS (N SIZE PUMPS)**



**TABLE 4: CONTROLLER TERMINAL DESCRIPTIONS (N SIZE PUMPS)**

Slot A		Slot C	
L1	Normally Open (Not Ready Light)	98	Power Input; AC; Fused (Controller)
K1	Common (Ready Light / Pump Interlock)	99	Common (Controller)
J1	Normally Closed (Ready Light)	CF	Not Used
W2	DC Output	CD	Not Used
Y2	DC Output	CE	Not Used
T1	Not Used	B5	Not Used
S1	Negative Thermocouple Lead (Usually red wire used)	D6	Not Used
R1	Positive Thermocouple Lead	D5	Not Used

**FIGURE 14: RELAY TERMINAL LOCATIONS (N SIZE PUMPS)**



**TABLE 5: RELAY TERMINAL DESCRIPTIONS (N SIZE PUMPS)**

Relay Terminal Definitions	
1	Not Used
2	Power Input; AC; Fused (From Power Source)
3	Common
4	Not Used
5	Heater
6	Heater
7	DC Input
8	DC Input
9 - 16	Not Used

## NOTES

1. Input power for the controller must be 240VAC<sup>®</sup>, single phase, 60 Hz or 220VAC, single phase, 50 Hz.
2. Controller terminals
  - a. 18 to 12 AWG wire size for heaters and controller. Use appropriate thermocouple wire for thermocouple and application.
  - b. Torque to 7.0 lb-in (0.8 Nm)
  - c. Wire strip length 0.30 in (7.6 mm).
3. Relay input terminals for use with N size pump only (terminals 7-16)
  - a. 24 to 16 AWG wire size
  - b. Torque to 4.4 lb-in (0.5 Nm)
  - c. Wire strip length of 0.22 in (5.5 mm)
4. Relay line and load terminals for use with N size pump only (terminals 1-6)
  - a. Will accept 18 to 8 AWG wire size
  - b. Torque to 12 lb-in (1.4 Nm)
  - c. Wire strip length 0.25 in (6.35 mm)
  - d. Retorque after 48 hours to minimize wire cold flow
  - e. Retorque terminals every 3 to 6 months
  - f. Ground terminal use spade terminal for No. 8 screw, with upturned lugs
  - g. Attach grounding wire to grounding screw (#6)

5. Maintain electrical isolation between thermocouple analog input 1 (terminals S1 and R1), any digital inputs-outputs, and process outputs 1 and 2 (For H-QS terminals L1, K1 and L2, K2, respectively. For N sizes terminals L1, K1 and W2, Y2 respectively), to prevent ground loops.
6. To prevent injury and damage to the controller, do not connect wires to unused terminals.
7. The wires for the heat cartridges can be joined together in a junction box, and a single wire from the junction box can be connected to the controller.
8. The wiring diagram is only valid for standard type J thermocouples and controllers supplied from Viking Pump.
9. For information on the location and installation of the heat cartridges and thermocouple, refer to **Installation: Heat Cartridges**. The thermocouple will require a fitting adapter which is included with the controller kit in order to mount to the pump.

## KEY LAYOUT & FUNCTIONS

### Upper Display

In the Home Page, displays the process value, otherwise displays the value of the parameter in the lower display.

### Zone Display

Indicates the controller zone.

### Lower Display

Indicates the set point or output power value during operation, or the parameter whose value appears in the upper display.

**EZ Key**  
Not used

**Advance Key**

Advances through parameter prompts.

**Infinity Key**

Press to back up one level, or press and hold for two seconds to return to the Home Page. From the Home Page, you can clear alarms and errors if clearable.

### Temperature Units

Indicates whether the temperature is displayed in Fahrenheit or Celsius.

### Percentage Units

Lights when the controller is displaying values as a percentage.

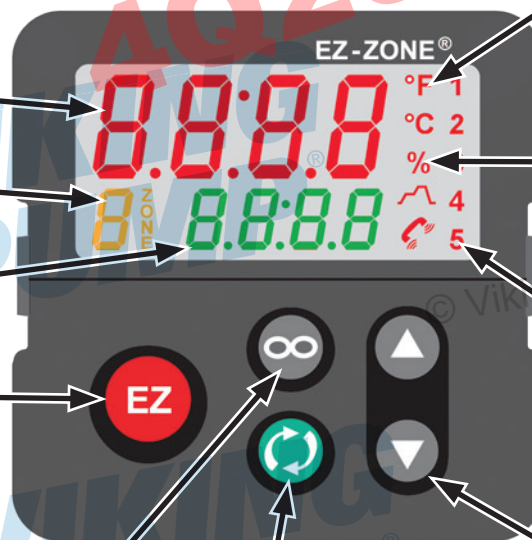
### Output Activity

Number LEDs indicate activity of outputs. A flashing light indicates output activity.

#2 indicates when power applied to heaters.

### Up and Down Arrow Keys

In the Home Page, adjusts the set point in the lower display. In other pages, changes the upper display to a higher or lower value, or changes the parameter selection.



### NOTE:

This controller has been pre-programmed by Viking Pump to lockout many functions to simplify installation and operation for customer specified electric heat applications. If advanced functionality is required, the user should source their own controller from a qualified heat control vendor.

## OPERATION

### WARNING !



Depending on the set point temperature at startup, the controller may deliver power to the heat cartridges and cause them to heat as soon as the controller is turned on.

### WARNING !

Setting the set point temperature higher than necessary will not make the pump heat any faster and will shorten the life of the heat cartridges.

1. Press and hold the Infinity Key for two seconds to bring up the Home Page.
2. Use the Up and Down Arrow Keys to adjust the set point temperature if necessary. The lower display of the Home Page shows the set point temperature. The set point temperature needs to be slightly higher than the melting point and significantly lower than the flash point or boiling point of the liquid being pumped.
3. To make sure that the liquid within the pump is melted and to avoid damage to the pump, do not start the pump until the set point temperature has been reached. Depending on your setup, there may be a ready light to indicate when the set point has been reached. On the Home Page, the upper display shows the process temperature, and the lower display shows the set point temperature.

## TROUBLESHOOTING

Error Code	Description	Possible Causes	Corrective Action
 Error Input	Sensor does not provide a valid signal to controller	<ol style="list-style-type: none"> <li>1. Thermocouple improperly wired or open</li> </ol>	<ol style="list-style-type: none"> <li>1. Correct wiring or replace thermocouple</li> </ol>
No heat action	Output does not activate load	<ol style="list-style-type: none"> <li>1. Output is incorrectly wired</li> <li>2. Load, power, or fuse is open</li> <li>3. Set point is incorrect</li> <li>4. Heat cartridge is burnt out*</li> </ol>	<ol style="list-style-type: none"> <li>1. Correct output wiring</li> <li>2. Correct fault in system</li> <li>3. Adjust set point to correct temperature</li> <li>4. Replace heat cartridge</li> </ol>
No display	No display indication or LED illumination	<ol style="list-style-type: none"> <li>1. Power to controller is off</li> <li>2. Fuse open</li> <li>3. Breaker tripped</li> <li>4. Safety interlock switch open</li> <li>5. Wiring error</li> <li>6. Incorrect voltage to controller</li> </ol>	<ol style="list-style-type: none"> <li>1. Turn on power</li> <li>2. Replace fuse between power source and controller</li> <li>3. Reset breaker</li> <li>4. Close interlock switch</li> <li>5. Correct wiring issue</li> <li>6. Check voltage requirements and apply correct voltage</li> </ol>
Temperature runaway	Process value continues to increase past set point	<ol style="list-style-type: none"> <li>1. Thermocouple reverse wired</li> <li>2. Controller output wired incorrectly</li> <li>3. Short in heater</li> <li>4. Power controller connection to controller defective</li> <li>5. Controller output defective</li> </ol>	<ol style="list-style-type: none"> <li>1. Correct thermocouple wiring (red wire negative)</li> <li>2. Verify and correct wiring</li> <li>3. Replace heater</li> <li>4. Replace or repair power controller</li> <li>5. Replace or repair controller</li> </ol>
 Device Error	Controller displays internal malfunction message at power up.	<ol style="list-style-type: none"> <li>1. Controller is defective</li> </ol>	<ol style="list-style-type: none"> <li>1. Replace or repair controller</li> </ol>

\* Use an ohmmeter or multimeter to determine the resistance across the heat cartridge. A burnt out heater will have a reading of infinity ( $\infty$ ) ohms. The customer supplied fuse between the heat cartridges and controller will typically blow when one of the heat cartridges fails.



## TECHNICAL DATA - CONTROLLER

Weight	6.6 oz. (186 g)
Supply Voltage	1x220-240 ( $\pm 10\%$ )
Frequency	50 or 60 Hz
Power Consumption	Max 10 VA
Fuses	Use Max 15 A
Terminal Wire Size	Use 18 to 12 AWG
Terminal Tightening Torque	7 lb-in (0.8 Nm)
Max Temperature Error @ Ambient	$\pm 3.15^\circ\text{F}$ ( $1.75^\circ\text{C}$ )
Sampling Rates for Input & Output	10 Hz
Heater Relay (L2,K2)	NO-ARC 15A, Form A
Ready Light Relay (L1,K1)	Mechanical Relay 5A, Form C
Operating Temperature	0-149°F (-18-65°C)
Storage Temperature	-40-185°F (-40-85°C)
Allowable Humidity	0 to 90%; non-condensing
Protection Class	NEMA 4X/IP66 if installed correctly (refer to step 4 of "Installation: Controller" on page 11)
Pollution Degree	Pollution Degree 2
Back-up Battery Information	<ul style="list-style-type: none"> <li>Allows for data retention upon power failure</li> <li>Battery Type: lithium (recycle properly)</li> <li>Typical Battery Life: three cumulative years of unpowered life at 77°F (25°C)</li> </ul>
Agency Approvals	<ul style="list-style-type: none"> <li>UL® Listed to UL® 61010-1 File E185611</li> <li>UL® Reviewed to CSA C22.2 No.61010-1-04</li> <li>UL® 50 Type 4X</li> <li>FM Class 3545 File 3029084 temperature limit switches</li> <li>CE, RoHS, and W.E.E. compliant</li> <li>Suitable for use in Class 1, Div 2, Groups A, B, C and D or non-hazardous locations only. Temperature Code T4A</li> <li>UL® Listed to ANSI/ISA 12.12.01-2007 File E184390</li> <li>CSA approved; CSA C22. No. 24 File 158031 Class 4813-02</li> <li>UL® reviewed to Standard No. CSA C22.2 No. 213-M1987</li> </ul>

## TECHNICAL DATA - RELAY


Weight	1.6 lbs (0.7 kg)
Supply Voltage	85V minimum - 660V maximum
Frequency	50 or 60 Hz
Power Consumption	1.2 watts per amp switched
Storage Temperature	-40 - +185°F (-40 - +85°C)
Allowable Humidity	0 to 90%; non-condensing
Protection Class	IP20
Pollution Degree	Pollution Degree 2
Classification	Power Control; Installation III
Agency Approvals	<ul style="list-style-type: none"> <li>UL® 508 Listed and C-UL®, File E73741</li> </ul>

## EU (EUROPEAN UNION) SPECIFICATIONS

The controller meets the essential requirements of the following European Union Directives by using the relevant standards shown below to indicate compliance

2004/108/EC Electromagnetic Compatibility Directive		
EN 61326-1	2006	Electrical equipment for measurement, control and laboratory use- EMC requirements (Industrial Immunity, Class B Emissions).
EN 61000-4-2	1996 +A1,A2	Electrostatic Discharge Immunity
EN 61000-4-3	2006	Radiated Field Immunity 10V/M 80-1000 MHz, 3 V/M 1.4-2.7 GHz
EN 61000-4-4	2004	Electrical Fast-Transient/Burst Immunity
EN 61000-4-5	2006	Surge Immunity
EN 61000-4-6	1996 +A1,A2,A3	Conducted Immunity
EN 61000-4-11	2004	Voltage Dips, Short Interruptions and Voltage Variations Immunity
EN 61000-3-2	2006	Harmonic Current Emissions
EN 61000-3-3	2005	Voltage Fluctuations and Flicker
SEMI F47	2000	Specification for Semiconductor Sag Immunity Figure R1-1
2006/95/EC Low-Voltage Directive		
EN 61010-1	2001	Safety Requirements of electrical equipment for measurement, control and laboratory use. Part 1: General requirements.
Compliant with 2002/95/EC RoHS Directive		

## DISMANTLING & DISPOSAL

 The enclosure is made of Polycarbonate material. Use proper recycling techniques.

Do not throw in trash. When disposing, the parts must be handled and recycled in accordance with local regulations. Per 2002/96/EC W.E.E. Directive, please recycle properly.

The controller contains a lithium battery that must be recycled properly

## APPENDIX (FORMERLY TSM 000)

**NOTE:** This Appendix section is for reference only. Not all pump construction features apply to pumps within this Technical Service Manual.

## GENERAL INSTALLATION NOTES

Before installation is started, a few items of a general nature should be considered.

- Location** - always locate the pump as close as possible to the supply of liquid to be pumped. Locate it below the liquid supply if at all practical. Viking pumps are self priming but the better the suction conditions the better the performance.
- Accessibility** - the pump should be located where it is accessible for inspection, maintenance, and repair. For large pumps, allow room to remove the rotor and shaft without removing the pump from the base.
- Port Arrangement** - since the pumps have different port arrangements depending on the model, port location should be checked before starting the installation. The ports may be upright, opposite or at right angles to each other, see **Figure A1**. The right angle ports are normally right-hand, see **Figure A2**; some models are available with left-hand arrangements; still other models are available with the right angle ports located in any one of eight positions including right-hand and left-hand.
- Suction/Discharge** - shaft rotation will determine which port is suction and which is discharge. A look at **Figure A3** will show how rotation determines which port is which. As the pumping elements (gears) come out of mesh, point "A" on **Figure A3**, liquid is drawn into the suction port. Then at point "B" the gears come into mesh, and the liquid is forced out the discharge port. Reversing the rotation reverses the flow through the pump. When determining shaft rotation, always look from the shaft end of the pump. Unless otherwise specified, rotation is assumed to be clockwise (CW), which makes the suction port on the right side of the pump. The idler pin, which is offset in the pump head, should be properly positioned toward and an equal distance between the port connections. See **Figure A3** for correct idler pin location in relation to pump ports.

FIGURE A1

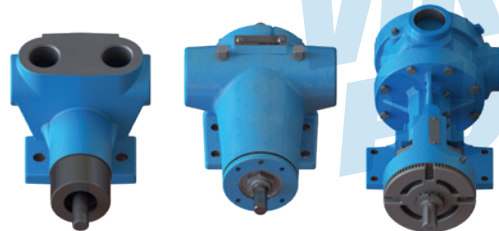
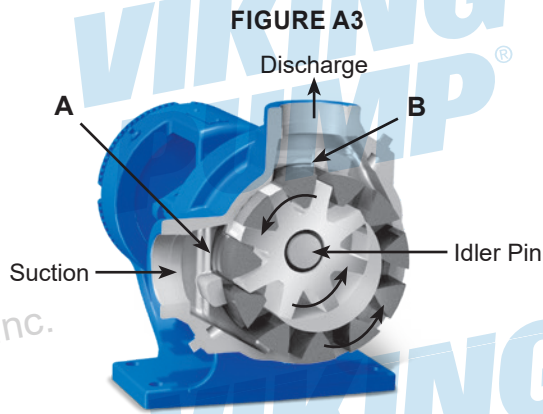


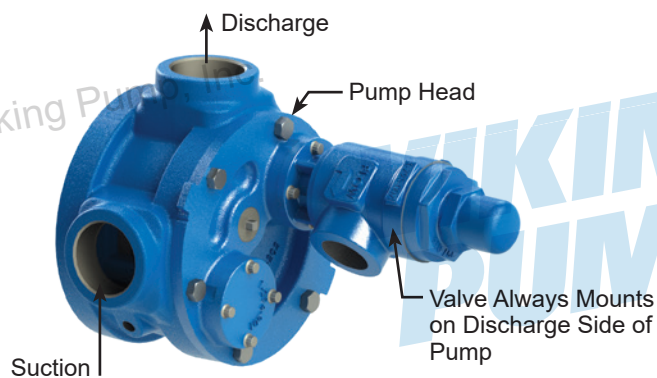
FIGURE A2



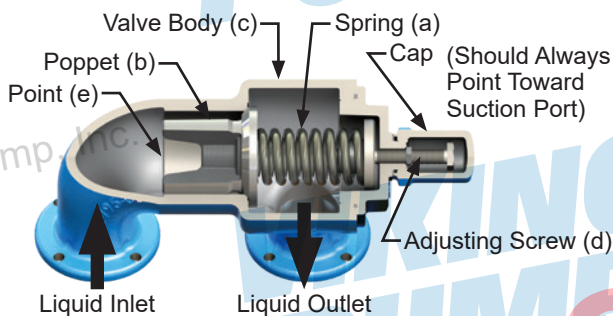


**FIGURE A3**

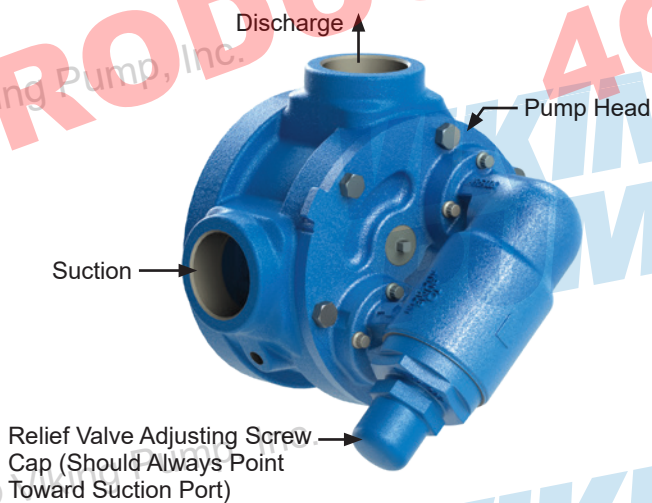
**FIGURE A5-B:  
RETURN-TO-TANK PRESSURE RELIEF VALVE**



**FIGURE A4:  
CUTAWAY OF VIKING INTERNAL  
PRESSURE RELIEF VALVE**



**FIGURE A5-A:  
INTERNAL PRESSURE RELIEF VALVE**



**⚠ CAUTION !**

Internal type relief valves mounted on Viking pumps should always have the cap or bonnet pointed toward the suction side of the pump. Return-to-tank type relief valves should always be mounted on the discharge side of the pump. If pump rotation is reversed, change the relief valve. Turn the internal type end for end; move the return-to-tank type to the other port. If on a particular installation rotation is reversed, e.g., using one pump to fill a tank, and then by use of a reversing switch or other means of changing the rotation to permit the same pump to circulate the liquid through a heater or to load out, then pressure protection must be provided on both sides of the pump for both rotations. This may be a combination of relief valves, torque limiting devices or rupture disks.

**⚠ CAUTION !**

Pumps or systems without relief valves should have some form of pressure protection, e.g. torque limiting devices or rupture disks.

**5. Pressure Protection** - Viking pumps are positive displacement pumps. This means that when the pump is rotated, liquid will be delivered to the discharge side of the pump. If there is no place for this liquid to go, i.e. the discharge line is blocked or closed, pressure can build up until the motor stalls, the drive equipment fails, a pump part breaks or ruptures, or the piping bursts. Because of this, some form of pressure protection must be used with a positive displacement pump. This may be a relief valve mounted directly on the pump, an inline relief valve, a torque limiting device or a rupture disk.

The pressure relief valve mounted on most Viking pumps and most in-line valves are of the spring-loaded poppet design. See **Figure A4**. The spring (a) holds poppet (b) against the seat in the valve body (c) with a given force determined by the spring size and by how tightly it is compressed by the adjusting screw (d). The pump discharge pressure pushes against the underside of the poppet at point (e). When the force exerted by the liquid under the poppet exceeds that exerted by the spring, the poppet lifts and liquid starts to flow through the valve.

As the discharge pressure builds up, more and more of the liquid flows through until a pressure is reached at which all of the liquid being pumped is going through the valve. This pressure is the relief valve setting.

Viking pumps can be furnished with either an internal pressure relief valve - one which directs the flow from the valve back to the suction side of the pump - or a return-to-tank valve - which directs the flow through piping back to the supply tank. See **Figure A5-A** and **Figure A5-B**.

An inline relief valve mounted in the discharge piping also directs the flow back to the supply tank. This type of valve should be mounted close to the pump so that the pressure drop through the piping between the pump and the valve is at a minimum. Be sure there are no shutoff valves between the pump and relief valve. Piping from a return-to-tank or an in-line valve to the supply tank should also be as short and as large as possible.

**NOTE:** On some models, the relief valve is mounted on the pump casing instead of the pump head.

The spring-loaded poppet-type valve is strictly a differential valve, sensing only those pressures on each side of the poppet. It should not be used as a pressure or flow control device. It is intended strictly as a relief valve.

The pressure at which either the return-to-tank or internal relief valve bypasses can be changed by turning the adjusting screw. Do not back the adjusting screw all the way out. Stop when spring tension is off the screw (the screw starts to turn easily). For details on maintenance of the relief valve, refer to the Technical Service Manual covering your model series.

- 6. **Motor** - follow local electrical codes when hooking up motors.

## FOUNDATION

Every pump should have a solid foundation. It may be any structure sufficiently strong to hold the pump rigid and to absorb any strain or shock that may be encountered.

A certified print of the pumping unit should be used in preparing the foundation. If a separate foundation is provided, make it at least four inches wider and longer than the base of the unit.

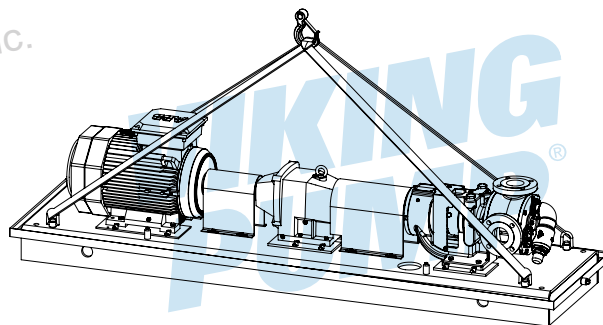
When the unit is placed on the foundation, it should be leveled and checked for position against the piping layout and then fastened down.

## COMPONENT & UNIT LIFTING FEATURES

Removable lifting features, such as threaded eye bolts and hoist rings, installed in components (pumps, reducers, motors, etc.) and baseplates should be left on the components.

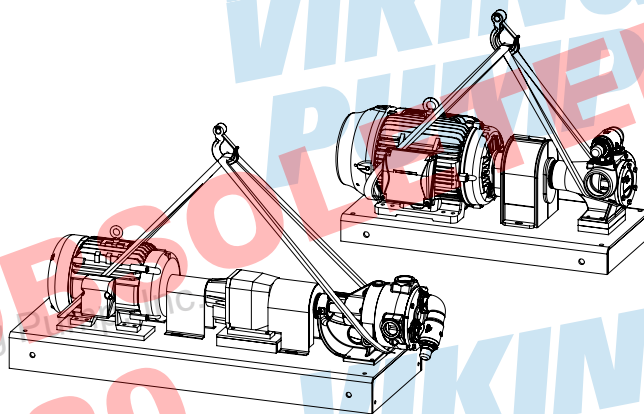
These features are used to safely lift and move the individual components. Following are general guidelines for lifting Viking Pump® units.

**FIGURE A6:**  
**EXAMPLE OF PROPER LIFTING METHOD**



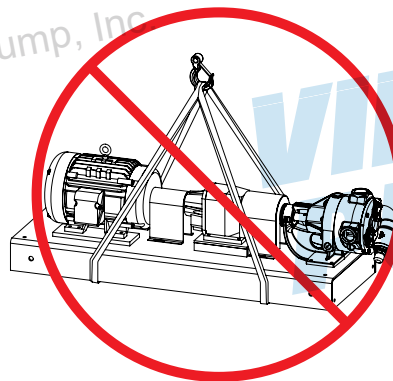
**NOTE:** Units should be lifted by the base lifting features using two or more lifting slings.

**FIGURE A7:**  
**EXAMPLES OF PROPER LIFTING METHOD**



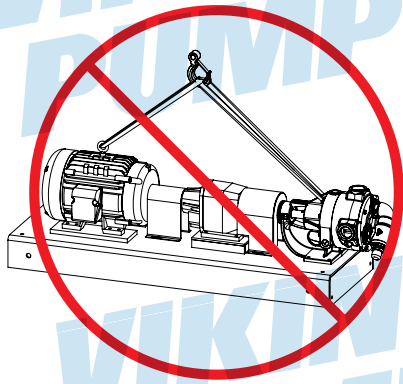
**NOTE:** Use two or more lifting slings around the pump and the motor when the base does not have lifting features. Make sure the slings are secure and the load is balanced before attempting to lift.

**FIGURE A8:**  
**EXAMPLE OF IMPROPER LIFTING METHOD**



**NOTE:** NEVER lift the unit with slings unsecured under the base. The slings can slide, allowing the unit to tip and/or fall. Improper lifts can result in personal injury and/or damage to the unit.

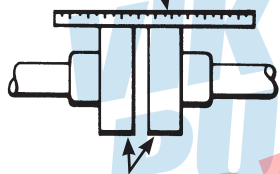
**FIGURE A9**  
**EXAMPLE OF IMPROPER LIFTING METHOD**



**NOTE: NEVER** lift the unit with slings connected to the component lifting features. The lifting features are designed for the individual component and are not rated to lift the entire unit. Improper lifts can result in personal injury and/or damage to the unit.

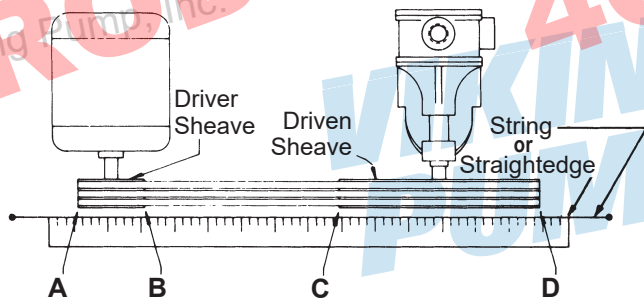
**FIGURE A10-A**

Use a straightedge. These surfaces must be parallel.



Check width between these surfaces with inside calipers to be certain the faces are equal distance apart and parallel.

**FIGURE A10-B**



When sheaves are properly aligned, all points A, B, C, D will touch string or straightedge.

## ALIGNMENT

### CHECK ALIGNMENT AFTER MOUNTING

*For detailed coupling alignment procedures see coupling manufacturers' recommendations.*

The pump, drive, and motor were properly aligned at the time they were assembled. During shipping and mounting the alignment is often disturbed. **BE SURE TO RECHECK ALIGNMENT AFTER THE PUMP UNIT IS INSTALLED!**

1. Check pump ports to be sure they are square and in the proper position; shim or move the pump as required. Do not force piping to line up with the ports.
2. If the pump is driven by a flexible coupling(s) either directly connected to the motor or through a reducer, remove any coupling guards or covers and check alignment of the coupling halves. At a minimum, a straightedge (such as a piece of key stock) across the coupling must rest evenly on both rims at the top, bottom, and sides.

See **Figure A10-A**.

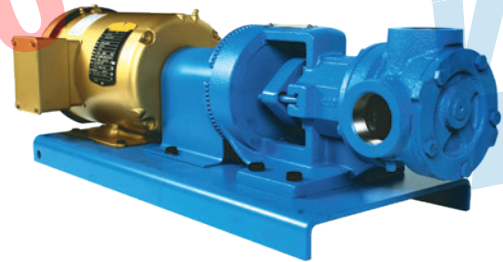
3. If the pump is driven by V-belts, check the alignment by using a long straightedge or tightly drawn string across the face of the sheaves. See **Figure A10-B**.

4. Make a final check on alignment after piping is hooked up. Refer to item 13 in **Piping** section.

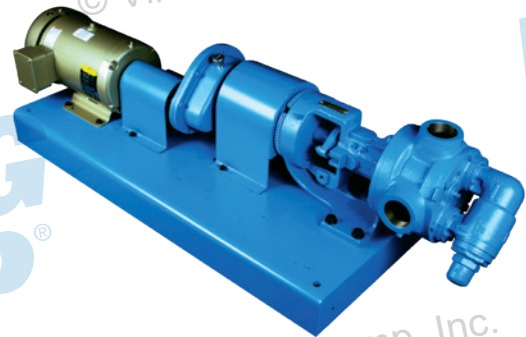
**Figure A11** and **Figure A12** show typical direct drive and gear reducer drive units.

5. For high temperature applications (those above 300°F) allow the pump to reach operating temperature, then recheck alignment.

**FIGURE A11: DIRECT DRIVE**



**FIGURE A12: REDUCER DRIVE**



## PIPING

The cause of many pumping problems can be traced to suction piping. It should always be as large and short as practical. For help in selecting the proper size suction and discharge piping, refer to **Viking General Catalog Section 510**.

Before starting the layout and installation of your piping system, consider the following points:

1. Never use piping smaller than the pump port connections.
2. Be sure the inside of the pipe is clean before hooking it to the pump.
3. **FOOT VALVE** - When pumping a light liquid with a suction lift, a foot valve at the end of the suction piping or a check valve in the first horizontal run will hold the liquid in the line and make it easier for the pump to prime. Be sure the foot or check valve is big enough so that it doesn't cause excessive line loss.
4. When approaching an obstacle in the suction or discharge line, go around the obstacle instead of over it. Going over it creates an air pocket. See **Figure A13**.
5. Where practical, slope the piping so no air or liquid pockets will be formed. Air pockets in the suction line make it hard for the pump to prime.
6. For a suction line with a long horizontal run, keep the horizontal portion below the liquid level if possible. This keeps the pipe full of liquid and reduces the amount of air the pump must evacuate at startup. This is most helpful when there is no foot valve. See **Figure A14**.
7. When piping a hot or cold system (liquid being handled is at a temperature different from the air surrounding the pump), be sure allowance is made for expansion and contraction of the piping. Loops, expansion joints, or unsecured (this does not mean unsupported) runs should be used so the pump casing is not distorted.
8. **STRAINER** - It is always good practice to consider a strainer on the suction side of a positive displacement pump. The strainer will keep foreign objects from going into the pump. Without a strainer objects can lock the pump, and damage the internals and drive. The strainer basket mesh or perforation size should be big enough so that it does not cause excessive pressure drop, but it should be fine enough to protect the pump. When in doubt as to the proper size, check with the manufacturer, giving pipe size, flow rate, and viscosity involved. Provision should be made for cleaning the strainer. If the pump operates continuously, a bypass should be built around the strainer, or two strainers should be put in parallel with proper valving so they can be isolated for cleaning. Use of a strainer is particularly important at start up to help clean the system of weld beads, pipe scale, and other foreign objects. For additional information, refer to **TSM 640**.
9. If the pump is not equipped with a relief valve, consideration should be given to mounting one in the discharge line. Refer to discussion on pressure protection under item 5 in **General Installation Notes** section.
10. The pump should not be used to support the piping. The weight of the piping should be carried by hangers, supports, stands, etc.
11. When fastening the piping to the pump it should not be necessary to impose any strain on the pump casing. "Springing" or "drawing" the piping up to the pump will

cause distortion, possible misalignment, and probable rapid wear of the pump. Do not use the pump to correct errors in piping layout or assembly.

12. All joints of the piping system should be tight; pipe sealer will help assure leak-free threaded joints. Leaks in the suction line permitting air to be drawn in may cause a noisy pump or a reduction in capacity. It is not recommended to use PTFE tape on NPT ports as a pipe sealer. This action can result in cracks in the pump.
13. **ALIGNMENT** - Check the alignment of the drive after the piping is hooked up. As a final check on pump alignment, remove the head of the pump and with a feeler gauge determine if there is clearance all the way around between the rotor and casing. Because of manufacturing tolerances, bushing clearances, etc., the rotor may not be centered in the casing, but it should not drag; dragging would indicate unit misalignment or casing distortion from piping strain. Making this check is most desirable on installations involving Q, M and N size general purpose pumps.
14. The auxiliary piping hooked to jackets, glands, etc. for heating, cooling, quenching, or for other purposes should receive the same attention as the piping handling the pumped liquid.
15. Provide a pressure relief device in any part of a pump and piping system that can be valved off and, thus, completely isolated. This is particularly important:
  - a. When handling a cold liquid such as refrigeration ammonia that can warm up to ambient temperatures when the pump is shut off.
  - b. When handling a liquid such as asphalt or molasses that has to be heated before it can be pumped.

The rise in temperature causes the liquid to expand; if there is no provision for pressure relief in the closed off section, there is a chance that the pump or piping will rupture.

FIGURE A13

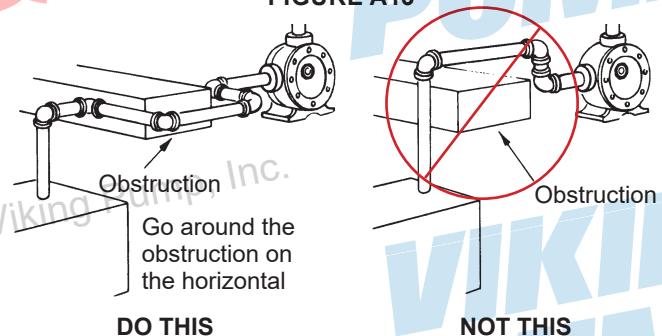
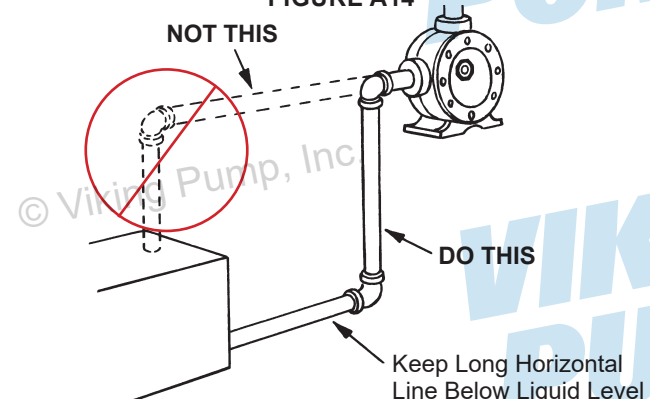


FIGURE A14



## START UP

Before starting the pump, check the following:

1. Are there vacuum and pressure gauges on or near the pump? These gauges are the quickest and most accurate way of finding out what is happening in the pump.
2. Check alignment - See suggestions in the Alignment section of this manual.
3. Check piping to be sure there is no strain on the pump casing.
4. Rotate the pump shaft by hand to be sure it turns freely. **MAKE SURE THE PUMP DRIVER IS LOCKED OUT OR CANNOT BE ENERGIZED BEFORE DOING THIS.**
5. Jog motor to be sure it is turning in the right direction; refer to discussion on pump rotation under item 4 in **General Installation Notes** section.
6. Check any relief valves to be sure they are installed correctly. Refer to discussion on relief valves in **General Installation Notes** section.
7. Check suction piping to be sure:
  - a. It is all connected and tight
  - b. Valves are open
  - c. End of pipe is below liquid level
8. Check discharge piping to be sure:
  - a. It is all connected and tight
  - b. Valves are open
  - c. There is a place for the liquid to go
9. Lubricate any grease fitting on the pump using a #2 NLGI polyurea grease. Check any gear reducer, motor, coupling, etc. for instructions and lubricate as recommended. Contact your Viking Pump® representative for **Engineering Service Bulletin ESB-515**.
10. For packed pumps, loosen packing gland nuts so gland can be moved slightly by hand. Adjust gland to reduce leakage only after pump has run long enough to reach constant temperature. Packing should weep a little to keep it cool and lubricated.
11. Do not use the Viking pump to flush, pressure test or prove the system with water. Either remove the pump or run piping around it while flushing or testing. Pumping water, dirty or otherwise, can do more damage in a few minutes than months of normal service.
12. Check to be sure all guards are in place.
13. Check the pump to be sure it is heated to operating temperature (if jacketed or heat traced).

If the pump begins to deliver liquid within 60 seconds, it can continue to be operated. If liquid is not leaving the discharge port, stop the pump. Running the pump longer than one minute without liquid inside it can damage the pump. Review the steps just outlined, consider what the suction and discharge gauges indicate, and see **Troubleshooting** section. If everything appears to be in order, put some liquid in the pump. This will help it prime.

The pump can be restarted. If nothing is flowing within two minutes, stop the pump. The pump is not a compressor; it will not build up much air pressure. It may be necessary to vent the discharge line until liquid begins to flow.

If the pump still does not deliver flow, the cause may be one or more of the following:

1. Suction line air leaks. Vacuum gauge reading should help determine if this is the problem.
2. End of suction pipe not submerged deep enough in liquid.
3. Suction lift is too great or the suction piping is too small.
4. Liquid is vaporizing in the suction line before it gets to the pump.

If after consideration of these points it still does not pump, review again all points under **START UP**. Read through **Troubleshooting** in this manual and try again. If it still does not pump, contact your Viking Pump® representative.

## TROUBLESHOOTING

A Viking pump that is properly installed and maintained will give long and satisfactory performance.

**NOTE:** Before making any pump adjustment or opening the pump liquid chamber in any manner, make sure that:

1. Any pressure in the pumping chamber has been vented through the suction or discharge lines or other openings provided for this purpose.
2. The driver has been "locked out" so that it cannot inadvertently be started while work is being done on the pump.
3. The pump has been allowed to cool down to the point where there is no chance of anyone being burned.

If trouble does develop, one of the first steps toward finding the difficulty is to *install a vacuum gauge in the suction port and a pressure gauge in the discharge port*. Readings on these gauges often will give a clue as to where to start looking for the trouble.

### VACUUM GAUGE - SUCTION PORT

#### 1. High reading would indicate:

- a. Suction line is blocked by a stuck foot valve, stuck gate valve, or plugged strainer.
- b. Liquid is too viscous to flow through the piping.
- c. Lift is too high.
- d. Line is too small.

#### 2. Low reading would indicate:

- a. Air leak in suction line.
- b. End of pipe is not in liquid.
- c. Pump is worn.
- d. Pump is dry - should be primed.

#### 3. Fluttering, jumping, or erratic reading:

- a. Liquid is vaporizing.
- b. Liquid is coming to pump in slugs, possibly an air leak, insufficient liquid above the end of the suction pipe.
- c. Vibrating from cavitation, misalignment, or damaged parts.

## PRESSURE GAUGE - DISCHARGE PORT

### 1. High reading would indicate:

- a. High viscosity, small diameter discharge line or long discharge line.
- b. Gate valve is partially closed.
- c. Filter is plugged.
- d. Vertical head did not consider a high specific gravity liquid.
- e. Line is partially plugged from build up on inside of pipe.
- f. Liquid in the pipe is not up to temperature.
- g. Liquid in the pipe has undergone a chemical reaction and has solidified.
- h. Relief valve is set too high.

### 2. Low reading would indicate:

- a. Relief valve is set too low.
- b. Relief valve poppet is not seating properly.
- c. Bypass around the pump is partially open.
- d. Too much extra clearance.
- e. Pump is worn.

### 3. Fluttering, jumping, or erratic reading:

- a. Cavitation.
- b. Liquid is coming to the pump in slugs.
- c. Air leak is in the suction line.
- d. Vibrating from misalignment or mechanical problems.

Some of the following may also help pinpoint the problem:

#### A. Pump does not pump.

1. Pump has lost its prime due to air leak, low level in tank, foot valve stuck.
2. Suction lift is too high.
3. Rotating in wrong direction.
4. Motor does not come up to speed.
5. Suction and discharge valves not open.
6. Strainer is clogged.
7. Bypass valve open, relief valve set too low, relief valve poppet stuck open.
8. Pump is worn out.
9. Any changes in the liquid system or operation that would help explain the trouble, e.g. new source of supply, added more lines, inexperienced operators, etc.
10. Too much extra clearance.
11. Head position is incorrect. See **Figure A3**.
12. Temperature changes either in the liquid or environment.
13. **Mag Drive pumps ONLY:** The magnetic coupling is decoupling. Changes in application (temperature, pressure, viscosity, etc.) may require torque beyond coupling capabilities.

#### B. Pump starts, then loses its prime.

1. Supply tank is empty.
2. Liquid is vaporizing in the suction line.
3. Air leaks or air pockets in the suction line; leaking air through packing or mechanical seal.
4. Pump is worn out.

#### C. Pump is noisy.

1. Pump is being starved (heavy liquid cannot get to pump fast enough). Increase suction pipe size or reduce length.
2. Pump is cavitating (liquid vaporizing in the suction line). Increase suction pipe size or reduce length. If pump is above the liquid, raise the liquid level closer to the pump. If the liquid is above the pump, increase the head of liquid.
3. Check alignment.
4. May have a bent shaft or rotor tooth. Straighten or replace.
5. Relief valve chatter. Increase pressure setting.
6. May have to anchor base or piping to eliminate or reduce vibration.
7. May be a foreign object trying to get into the pump through the suction port.
8. **Mag Drive pumps ONLY:** The magnetic coupling has decoupled. Shut off and let cool, then restart.

#### D. Pump not up to capacity.

1. Starving or cavitating. Increase suction pipe size or reduce length.
2. Strainer partially clogged.
3. Air leak in suction piping or along pump shaft.
4. Running too slowly. Check the motor is running at the correct speed and that it is wired correctly.
5. Bypass line around pump partially open.
6. Relief valve set too low or stuck open.
7. Pump is worn out.
8. Too much end clearance.
9. Head position incorrect. See **Figure A3**.

#### E. Pump takes too much power.

1. Running too fast. Verify the motor speed, reducer ratio, sheave size, and other drive components are correct for the application?
2. The liquid is too viscous for the size of the unit. Heat the liquid to reduce viscosity, increase the pipe size, slow down the pump, or use a larger motor.
3. Discharge pressure higher than calculated. Verify with a pressure gauge. Increase size or reduce length of pipe, reduce speed (capacity), or get bigger motor.
4. Packing gland drawn down too tight.
5. Pump misaligned.
6. Extra clearance on pumping elements may not be sufficient for operating conditions. Check parts for evidence of drag or contact in pump and increase clearance where necessary.
7. System pressure relief valve is set too high.
8. Bushings have locked to shaft or pin, or the liquid has set up in the pump.

#### F. Rapid Wear.

On most applications the pump will operate for many months or years before it gradually loses its ability to deliver capacity or pressure. Examination of such a pump would show a smooth wear pattern on all parts. Rapid wear, occurring in a few minutes, hours or days, shows up as heavy grooving, galling, twisting, breaking or similar severe signs of trouble. See **Rapid Wear Table**.



## RAPID WEAR

RAPID WEAR TABLE

CAUSE	EVIDENCE	POSSIBLE SOLUTION
1 ABRASIVES	Gouges or marks made by large, hard particles; a rapid wearing away of bushings from very small abrasives; or anything in between.	Flush the system with the pump removed. Install strainer in suction line. Most abrasive objects and particulate is removed after a few cycles (or days) of flushing.
2 CORROSION	Rust, pitting or metal appears to be "eaten" away.	Check the Viking General Catalog Liquid List for materials of construction recommendation. Consider whether all of the materials used in pump construction were attacked; consider other materials used in the system to determine how they resisted the liquid. Check to see whether or not the liquid has been contaminated to make it more corrosive than anticipated.
3 EXCEEDING OPERATING LIMITS	Noisy operation, broken bushings, twisted shaft, parts show evidence of high heat (discoloration).	Review General Catalog for operating limits on particular model involved.
4 INSUFFICIENT EXTRA CLEARANCE	Pump may stall. Evidence of heavy contact between end of rotor teeth and head or other parts.	Increase end clearance and/or contact your Viking Pump® representative with details of the application, so that information regarding proper extra clearance may be provided.
5 LACK OF LUBRICATION	Noisy bearings, localized heating at bearings or lip seal, smoke, rapid bushing wear.	Be sure all grease fittings are greased before starting, and instructions for lubrication of drive equipment are followed; consider use of auxiliary lubricating equipment.
6 MISALIGNMENT	Wear on only one part of a surface, e.g., one side of the casing, one side of the packing gland, only a portion of the face of the head.	Double check alignment of drive equipment and piping. Check the alignment under conditions as close to operating conditions as possible.
7 RUN DRY	Pump stalls because parts have uneven expansion caused by frictional heat; galling between surfaces; having relative motion; seal seats and idler pins changing color because of high heat.	Be sure there is liquid in the system at the time of start up. Provide some kind of automatic alarm or shut-off if supply tank runs dry.

## PREVENTATIVE MAINTENANCE

Performing a few preventative maintenance procedures will extend the life of your pump and reduce the overall cost of ownership.

**A. Lubrication** - Grease all grease fittings after every 2000 hours of operation. If service is severe, grease more often. Do it gently with a hand gun until the grease exiting the lip seal or relief plug is similar in consistency and color to the new grease.

Use a NLGI #2 polyurea grease for normal applications. For hot or cold applications, use appropriate grease.

**B. Packing Adjustment** - Occasional packing adjustment may be required to keep leakage to a slight weep. If impossible to reduce leakage by gentle tightening, replace packing or use different type. Refer to *Technical Service Manual on particular model series for details on repacking.*

**C. End Clearance Adjustment** - After long service, the running clearance between the end of the rotor teeth and the head may have increased through wear. This wear may cause a loss of capacity or pressure. Resetting end clearance will normally improve pump performance. Refer to *TSM on particular model series for procedure on adjusting end clearance for pump involved.*

**D. Examine Internal Parts** - Periodically remove the head, examine idler and bushing and head and pin for wear. Replacing a relatively inexpensive idler bushing and idler pin after only moderate wear will eliminate the need to replace more expensive parts at a later date. Refer to *TSM on particular model series for procedure in removing head of the pump.* Be sure idler does not slide off the idler pin as the head is removed. If it does slide off the idler can cause personal injury or damage the part.

**E. Cleaning the Pump** - A clean pump is easier to inspect, lubricate, adjust, and runs cooler.

**F. Storage** - If pump is to be stored or not used for six months or more, pump must be drained, and a light coat of non-detergent SAE 30 weight oil must be applied to all internal pump parts. Lubricate fittings and apply grease to pump shaft extension. Viking suggests rotating pump shaft by hand one complete revolution every 30 days to circulate the oil. Retighten all gasketed joints before using the pump.

## DO'S & DON'TS

Do's and Don'ts for installation, operation, and maintenance of Viking pumps to assure safe, long, trouble-free operation.

### INSTALLATION

1. **DO** install pump as close to supply tank as possible.
2. **DO** leave working space around the pumping unit.
3. **DO** use large, short, and straight suction piping.
4. **DO** install a strainer in the suction line.
5. **DO** double check alignment after the unit is mounted and piping is hooked up.
6. **DO** provide a pressure relief valve for the discharge side of the pump.
7. **DO** cut out the center of gaskets used as port covers on flanged port pumps.
8. **DO** record pump model number and serial number and file for future reference.

### OPERATION

1. **DON'T** run pump at speeds faster than shown in the catalog for your model.
2. **DON'T** require pump to develop pressures higher than those shown in the catalog for your model.
3. **DON'T** operate pumps at temperatures above or below limits shown in the catalog for your pump.
4. **DON'T** operate pumps without all guards being in place.
5. **DON'T** operate pump without a relief valve on the pump or in the discharge piping. Be sure valve is mounted and set correctly.
6. **DON'T** exceed catalog limits for temperature and pressures of fluids in jacketed areas of pump.
7. **DON'T** use the pump in a system which includes a steam, air, or vapor blow or purge **without** provision for over-speed shutdown, in case the pump starts to act as a turbine and over-speeds the drive.
8. **DON'T** operate the pump with all of the liquid bypassing through a pump mounted internal type relief valve, or without any flow of liquid going through the pump for more than a couple of minutes. Operation under either of these conditions may result in a heat build-up in the pump, which could cause hazardous conditions or happenings.

## MAINTENANCE

1. **DO** make sure any pump that has residual system pressure in it, or that has handled high vapor pressure liquids, such as LP-gas, ammonia, Freons, etc., has been vented through the suction or discharge lines or other openings provided for this purpose.
2. **DO** make sure that if the pump is still hooked to the driver while maintenance is being performed that the driver has been "locked out", so that it cannot be inadvertently started while work is being done on the pump.
3. **DO** make sure any pump that has handled a corrosive, flammable, hot, or toxic liquid has been drained, flushed, vented and/or cooled before it is disassembled.
4. **DO** remember that a few simple preventative maintenance procedures such as periodic lubrication, adjustment of end clearance, examination of internal parts, etc., will extend the service life of your pump.
5. **DO** obtain, read and keep maintenance instructions furnished with your pump.
6. **DO** have spare parts, pumps or standby units available, particularly if the pump is an essential part of a key operation or process.
7. **DON'T** drop parts during disassembly, e.g., idler can slip from the pin as the head is removed from the pump. It may cause personal injury or damage the part.
8. **DON'T** stick fingers in the ports of a pump. Serious injury may result.
9. **DON'T** spin the idler on the idler pin. Fingers may be jammed between teeth and crescent.

TECHNICAL SERVICE MANUAL: INSTALLATION, OPERATION & MAINTENANCE



LIQUID SPECIFIC PRODUCT LINE: CAST IRON  
32E SERIES™ & SINGLE CHANNEL CONTROLLER  
SIZES: LQ, Q, M, N

TSM	1466
Page	27 of 27
Issue	A

**VIKING PUMP®**

**WARRANTY**

Viking pumps, strainers and reducers are warranted to be free of defects in material and workmanship under normal conditions of use and service. The warranty period varies by type of product. A Viking product that fails during its warranty period under normal conditions of use and service due to a defect in material or workmanship will be repaired or replaced by Viking. At Viking's sole option, Viking may refund (in cash or by credit) the purchase price paid to it for a Viking product (less a reasonable allowance for the period of use) in lieu of repair or replacement of such Viking product. Viking's warranty is subject to certain restrictions, limitations, exclusions and exceptions. A complete copy of Viking's warranty, including warranty periods and applicable restrictions, limitations, exclusions and exceptions, is posted on Viking's website ([www.vikingpump.com/warranty/warranty-info](http://www.vikingpump.com/warranty/warranty-info)). A complete copy of the warranty may also be obtained by contacting Viking through regular mail at Viking Pump, Inc., 406 State Street, Cedar Falls, Iowa 50613, USA.

THIS WARRANTY IS AND SHALL BE VIKING'S SOLE AND EXCLUSIVE WARRANTY AND IS IN LIEU OF ALL OTHER WARRANTIES, EXPRESS OR IMPLIED, INCLUDING, BUT NOT LIMITED TO, ALL WARRANTIES OF MERCHANTABILITY, FITNESS FOR A PARTICULAR PURPOSE AND NON-INFRINGEMENT, ALL OF WHICH OTHER WARRANTIES ARE EXPRESSLY EXCLUDED.

THE RIGHTS AND REMEDIES UNDER THIS WARRANTY ARE AND SHALL BE THE SOLE AND EXCLUSIVE RIGHTS AND REMEDIES AGAINST VIKING. EXCEPT FOR THE SPECIFIC LIABILITIES AND OBLIGATIONS PROVIDED UNDER THIS WARRANTY, VIKING SHALL HAVE NO LIABILITY OR OBLIGATION WITH RESPECT TO ANY PRODUCT CLAIMED TO BE DEFECTIVE IN ANY MANNER.

UNDER NO CIRCUMSTANCES SHALL VIKING BE LIABLE UNDER THIS WARRANTY OR OTHERWISE FOR SPECIAL, INCIDENTAL, INDIRECT, CONSEQUENTIAL OR PUNITIVE DAMAGES OF ANY KIND, INCLUDING, BUT NOT LIMITED TO, LOST OR UNREALIZED SALES, REVENUES, PROFITS, INCOME, COST SAVINGS OR BUSINESS, LOST OR UNREALIZED CONTRACTS, LOSS OF GOODWILL, DAMAGE TO REPUTATION, LOSS OF PROPERTY, LOSS OF INFORMATION OR DATA, LOSS OF PRODUCTION, DOWNTIME, OR INCREASED COSTS, IN CONNECTION WITH ANY PRODUCT, EVEN IF VIKING HAS BEEN ADVISED OR PLACED ON NOTICE OF THE POSSIBILITY OF SUCH DAMAGES AND NOTWITHSTANDING THE FAILURE OF ANY ESSENTIAL PURPOSE OF ANY PRODUCT.