



# TECHNICAL SERVICE MANUAL

INDUSTRIAL HEAVY DUTY MOTOR SPEED PUMPS

SERIES 4076 AND 4176

SIZES HLE, ATE AND ALE

SECTION	TSM 710.1
PAGE	1 OF 8
ISSUE	C

## CONTENTS

Introduction . . . . .	1
Safety Information. . . . .	2
Special Information . . . . .	3
Rotation. . . . .	3
Pressure Relief Valves . . . . .	3
Maintenance . . . . .	3
Lubrication . . . . .	3
Cleaning the Pump . . . . .	3
Storage . . . . .	3
Suggested Repair Tools . . . . .	3
Disassembly . . . . .	4
Assembly . . . . .	4
Mechanical Seal . . . . .	5
Thrust Bearing Adjustment . . . . .	5
Installation of Carbon Graphite Bushings . . . . .	6
Installation of Foot . . . . .	6
Pressure Relief Valve Instructions . . . . .	6
Relief Valve Pressure Adjustment . . . . .	6

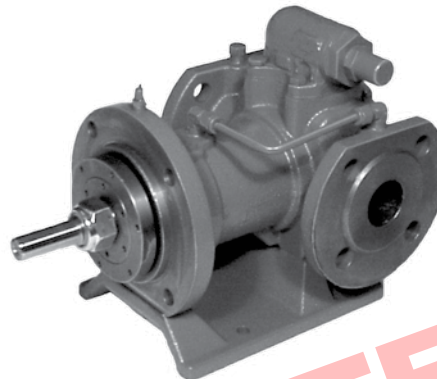

**FIGURE 1**

**Model HLE4176**

(Shown with relief valve on pump casing and foot mounting)

## INTRODUCTION

The illustrations used in this manual are for identification purposes only and cannot be used for ordering parts. Obtain a parts list from the factory or a Viking® representative. Always give complete name of part, part number and material with model number and serial number of pump when ordering repair parts. The pump model number and serial number are on the nameplate.

This manual deals only with Viking 4076/4176 pumps. Specifications and recommendations are listed in Catalog Section 710.

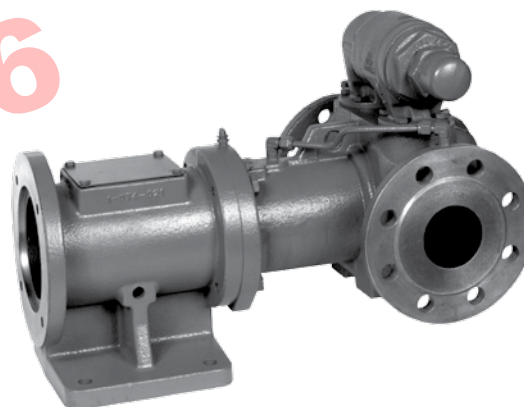

**FIGURE 2**

**Model ALE 4076**

(Shown with relief valve on pump casing and flange mounting – M Drive)

UNMOUNTED PUMP		UNITS
Flange Mounted	Foot Mounted	Units are designated by the unmounted pump model numbers followed by a letter indicating drive style. <b>M</b> = Horizontal with bracket <b>D</b> = Direct Drive <b>R</b> = Viking Reducer Drive <b>P</b> = Commercial Reducer Drive
HLE4076	HLE4176	
ATE4076	ATE4176	
ALE4076	ALE4176	

**TABLE 1**

# SAFETY INFORMATION AND INSTRUCTIONS

IMPROPER INSTALLATION, OPERATION OR MAINTENANCE OF PUMP MAY CAUSE SERIOUS INJURY OR DEATH AND/OR RESULT IN DAMAGE TO PUMP AND/OR OTHER EQUIPMENT. VIKING'S WARRANTY DOES NOT COVER FAILURE DUE TO IMPROPER INSTALLATION, OPERATION OR MAINTENANCE.

THIS INFORMATION MUST BE FULLY READ BEFORE BEGINNING INSTALLATION, OPERATION OR MAINTENANCE OF PUMP AND MUST BE KEPT WITH PUMP. PUMP MUST BE INSTALLED, OPERATED AND MAINTAINED ONLY BY SUITABLY TRAINED AND QUALIFIED PERSONS.

THE FOLLOWING SAFETY INSTRUCTIONS MUST BE FOLLOWED AND ADHERED TO AT ALL TIMES.

Symbol Legend :



**Danger** - Failure to follow the indicated instruction may result in serious injury or death.

**WARNING**

**Warning** - In addition to possible serious injury or death, failure to follow the indicated instruction may cause damage to pump and/or other equipment.



**BEFORE** opening any liquid chamber (pumping chamber, reservoir, relief valve adjusting cap fitting, etc.) be sure that :

- Any pressure in the chamber has been completely vented through the suction or discharge lines or other appropriate openings or connections.
- The pump drive system means (motor, turbine, engine, etc.) has been "locked out" or otherwise been made non-operational so that it cannot be started while work is being done on the pump.
- You know what material the pump has been handling, have obtained a material safety data sheet (MSDS) for the material, and understand and follow all precautions appropriate for the safe handling of the material.

**WARNING**

**INSTALL** pressure gauges/sensors next to the pump suction and discharge connections to monitor pressures.



**WARNING**

**USE** extreme caution when lifting the pump. Suitable lifting devices should be used when appropriate. Lifting eyes installed on the pump must be used **only** to lift the pump, **not** the pump with drive and/or base plate. If the pump is mounted on a base plate, the base plate must be used for all lifting purposes. If slings are used for lifting, they must be safely and securely attached. For weight of the pump alone (which does not include the drive and/or base plate) refer to the Viking Pump product catalog.



**BEFORE** operating the pump, be sure all drive guards are in place.



**DO NOT** attempt to dismantle a pressure relief valve that has not had the spring pressure relieved or is mounted on a pump that is operating.



**DO NOT** operate pump if the suction or discharge piping is not connected.



**AVOID** contact with hot areas of the pump and/or drive. Certain operating conditions, temperature control devices (jackets, heat-tracing, etc.), improper installation, improper operation, and improper maintenance can all cause high temperatures on the pump and/or drive.



**DO NOT** place fingers into the pumping chamber or its connection ports or into any part of the drive train if there is **any possibility** of the pump shafts being rotated.



**WARNING**

**THE PUMP** must be provided with pressure protection. This may be provided through a relief valve mounted directly on the pump, an in-line pressure relief valve, a torque limiting device, or a rupture disk. If pump rotation may be reversed during operation, pressure protection must be provided on **both** sides of pump. Relief valve adjusting screw caps must always point towards suction side of the pump. If pump rotation is reversed, position of the relief valve must be changed. Pressure relief valves cannot be used to control pump flow or regulate discharge pressure. For additional information, refer to Viking Pump's Technical Service Manual TSM 000 and Engineering Service Bulletin ESB-31.



**WARNING**

**DO NOT** exceed the pumps rated pressure, speed, and temperature, or change the system/duty parameters from those the pump was originally supplied, without confirming its suitability for the new service.



**WARNING**

**BEFORE** operating the pump, be sure that:

- It is clean and free from debris
- all valves in the suction and discharge pipelines are fully opened.
- All piping connected to the pump is fully supported and correctly aligned with the pump.
- Pump rotation is correct for the desired direction of flow.



**WARNING**

**THE PUMP** must be installed in a matter that allows safe access for routine maintenance and for inspection during operation to check for leakage and monitor pump operation.

## SPECIAL INFORMATION

### DANGER !

Before opening any Viking pump liquid chamber (pumping chamber, reservoir, relief valve adjusting cap fitting, etc.) be sure:

1. That any pressure in the chamber has been completely vented through the suction or discharge lines or other appropriate openings or connections.
2. That the driving means (motor, turbine, engine, etc.) has been "locked out" or made non-operational so that it cannot be started while work is being done on the pump.
3. That you know what liquid the pump has been handling and the precautions necessary to safely handle the liquid. Obtain a material safety data sheet (MSDS) for the liquid to be sure these precautions are understood.

Failure to follow the above listed precautionary measures may result in serious injury or death.

### ROTATION:

See **Figure 3**. Viking 4076/4176 pumps are directional due to the loading groove in the head. Standard rotation is clockwise as viewed from the shaft end.

If rotation is to be reversed, the following items need to be changed:

1. The head and pin assembly must be replaced.
2. Position of the relief valve will have to be changed. Install so the adjusting screw cap points towards the suction side of the pump.
3. The flush line must be switched to the opposite port.

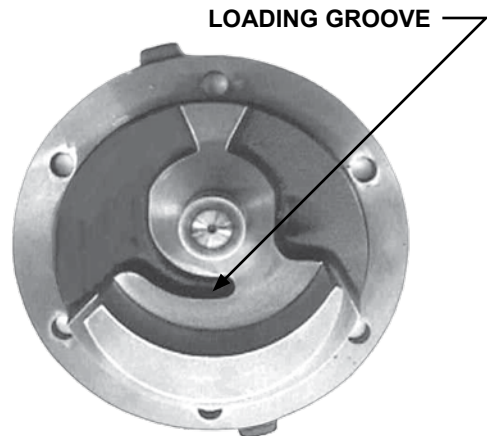

**FIGURE 3**

(Counter Clockwise Rotation Shown)

### PRESSURE RELIEF VALVES:

Viking pumps are positive displacement pumps and must be provided with some form of pressure protection. This may be a relief valve mounted directly on the pump, an in-line pressure relief valve, a torque limiting device or a rupture disk.

Pumps equipped with relief valves have them mounted on the casing.

If pump rotation is reversed during operation, pressure protection must be provided on both the sides of the pump. The relief valve adjusting screw cap must always point towards the pump suction port.

Pressure relief valves are intended for use as a protection for the pump only and should not be used to control pump flow or regulate discharge pressure.

## MAINTENANCE

Viking 4076/4176 pumps are designed for long, trouble-free service life under a variety of application conditions with a minimum of maintenance. The following points will help provide long service life.

### LUBRICATION:

External lubrication must be applied slowly with a hand gun to the lubrication fitting every 500 hours of operation with multi-purpose grease, NLGI #2. Do not over-grease. Applications involving very high or low temperatures will require other types of lubrication. Refer to Engineering Service Bulletin ESB-515. Consult factory with specific lubrication questions.

Note that the bushings used in this pump do not require any external lubrication.

### CLEANING THE PUMP:

Keep the pump as clean as possible. This will facilitate inspection, adjustment and repair work and help prevent overlooking a dirt covered grease fitting.

### STORAGE:

If the pump is to be stored, or not used for six months or more, pump must be drained and a light coat of non-detergent SAE 30 weight oil must be applied to all internal pump parts. Lubricate the fittings and apply grease to the pump shaft extension. Viking suggests rotating the pump shaft by hand one complete revolution every 30 days to circulate the oil.

### SUGGESTED REPAIR TOOLS:

The following tools must be available to properly repair Viking series 4076/4176 pumps. These tools are in addition to standard mechanics' tools such as open end wrenches, pliers and screw drivers. Most items can be obtained from an industrial supply house.

1. Soft headed hammer
2. Allen wrenches
3. Bearing locknut spanner wrench
4. Spanner wrench, adjustable pin type for use on bearing housing end cap
5. Brass bar or wood block
6. Arbor press

## DISASSEMBLY

### DANGER !

Before opening any Viking pump liquid chamber (pumping chamber, reservoir, relief valve adjusting cap fitting, etc.) Be sure:

1. That any pressure in the chamber has been completely vented through the suction or discharge lines or other appropriate openings or connections.
2. That the driving means (motor, turbine, engine, etc.) has been "locked out" or made non-operational so that it cannot be started while work is being done on pump.
3. That you know what liquid the pump has been handling and the precautions necessary to safely handle the liquid. Obtain a material safety data sheet (MSDS) for the liquid to be sure these precautions are understood.

Failure to follow above listed precautionary measures may result in serious injury or death.

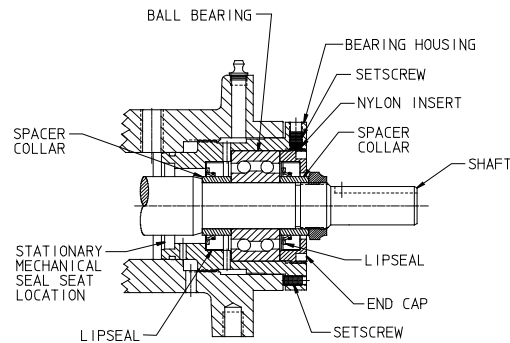

FIGURE 4

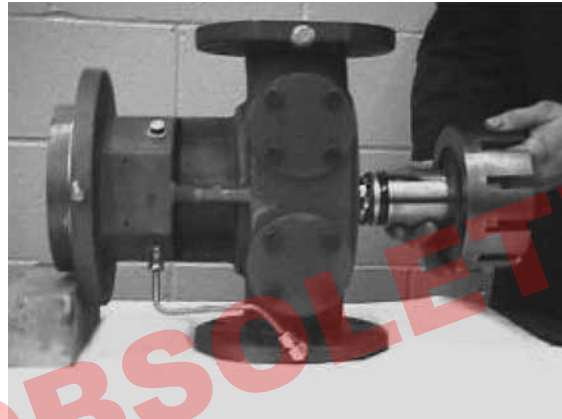

FIGURE 5

1. Remove the head capscrews. Remove the head of the pump. Do not allow the idler to fall from the idler pin. To prevent this from happening, tilt the top of the head back when removing. Avoid damaging the head o-ring. If the pump is furnished with a jacketed head plate, it will separate from the head when the capscrews are removed. Avoid damaging the jacketed head plate o-ring.
2. Remove the idler and bushing assembly.
3. Insert a length of hardwood or brass through either port opening between the rotor teeth to keep the shaft from turning. Remove the lock nut using a standard open end wrench.
4. Loosen the two setscrews in the face of the bearing housing and unthread the bearing housing assembly from the bracket. The end of the bearing housing contains the mechanical seal seat. Avoid damaging this surface. See **FIGURE 4**.
5. Remove the rotor and shaft assembly being careful to avoid damaging the mechanical seal face and casing bushing.
6. Remove the rotating member of the mechanical seal from the shaft only if the seal is to be replaced.

1. Install the casing bushing. See "**INSTALLATION OF CARBON GRAPHITE BUSHINGS**" on page 6.
2. Apply a light coating of oil onto the shaft in the seal area. Install the rotating member of the mechanical seal onto the rotor and shaft assembly. Slide the seal all the way to the shoulder on the shaft.
3. Slide the rotor and shaft assembly into the casing, taking care not to damage the bushing or the mechanical seal face.

**NOTE:** When installing a new rotor and shaft assembly, use a file to carefully remove all burrs and sharp edges.

4. Coat the head o-ring with oil or grease and slip it over the head pilot to keep it in place. Apply a coating of light oil onto the bushing inside diameter and the crescent. Place the idler and bushing assembly onto the idler pin.

**NOTE:** When installing a new head and pin assembly, use a file to carefully remove all burrs and sharp edges, especially around the loading groove.

5. Install the head. For proper head positioning, the pin should be at the top centered between the two ports. If the pump is equipped with a jacketed head plate, make sure the o-ring is in place and install at this time. Tighten the capscrews evenly.

Refer to **FIGURE 4** for bearing housing assembly.

6. Install the lip seal in the bearing housing. See **FIGURE 4** for lip orientation.
7. Pack the ball bearing with grease and push or press the bearing into the bearing housing.

## ASSEMBLY

**NOTE:** To facilitate assembly, place the pump casing so that it is standing on one of its flanges with a block of wood under the mounting flange. See **FIGURE 5**.

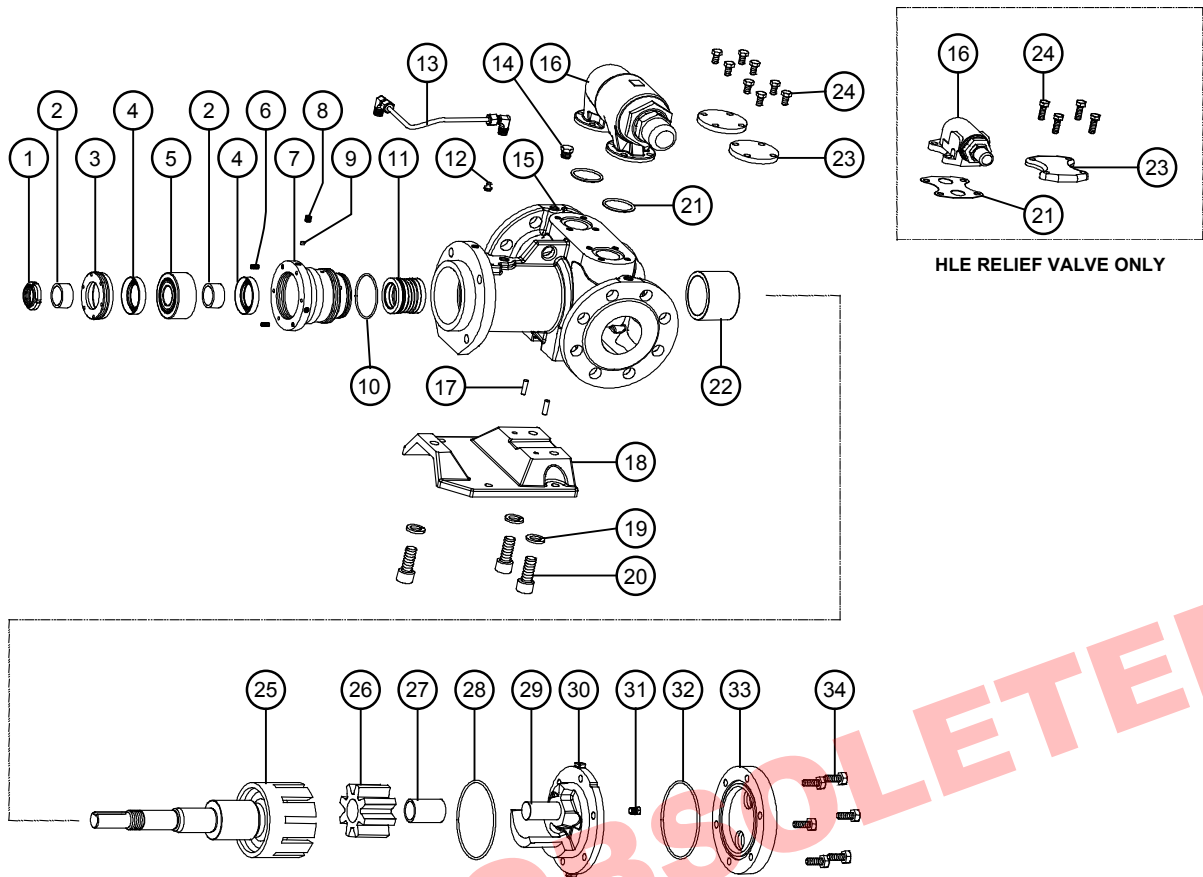

**FIGURE 6**  
**EXPLODED VIEW OF VIKING SERIES 4076 / 4176 PUMPS**

ITEM	NAME OF PART	ITEM	NAME OF PART	ITEM	NAME OF PART
1	Locknut	13	Flush Line Assembly	25	Rotor and Shaft Assembly
2	Bearing Spacer Collar (2-Req'd)	14	Pipe Plug	26	Idler and Bushing Assembly
3	End Cap	15	Casing and Bushing Assembly	27	Idler Bushing
4	Lip Seal (2-Req'd)	16	Relief Valve Assembly	28	O-Ring For Head
5	Ball Bearing	17	Dowel Pin (2-Req'd - 4176 Series Only)	29	Idler Pin
6	Setscrew (2-Req'd)	18	Foot (4176 Series Only)	30	Head and Lube Idler Pin Assembly
7	Bearing Housing	19	Lockwashers for Foot (4176 Series Only)	31	Pipe Plug, Hex Head, 1/8" BSP (ALE & ATE)
8	Setscrew (2-Req'd)	20	Capscrews for Foot (4176 Series Only)	32	O-Ring For Jacketed Head Plate (Optional)
9	Nylon Insert (2-Req'd)	21	Relief Valve Gasket (2-Req'd on ATE & ALE)	33	Jacketed Head Plate (Optional)
10	O-Ring For Seal Seat	22	Casing Bushing	34	Head Capscrews
11	Mechanical Seal	23	Cover Plate (Pumps Less Valve 2-Req'd on ATE & ALE)	Not Illus.	Pipe Flange Gasket (2-Req'd)
12	Grease Fitting	24	Capscrews for Relief Valve or Cover Plate		

**TABLE 2**

8. Install the lip seal in the end cap. See **FIGURE 4** for lip orientation. Thread the end cap into the bearing housing along with the outer bearing spacer collar. Tighten the end cap. Lock the end cap in place with two radial setscrews in the flange of the bearing housing.
9. See **FIGURE 7** and notes under "**MECHANICAL SEAL**" on this page. Lubricate the outside diameter of the seat gasket and install the stationary member of the mechanical seal into the end of the bearing housing. **Note** the shiny side of the seal seat faces out.
10. Slide the inner bearing spacer collar onto the shaft. Thread the bearing housing assembly into the bracket.
11. Insert a length of hardwood or brass through either port opening between the rotor teeth. This will keep the shaft from turning when the lock nut is tightened. Install the lock nut and tighten to 70-95 N•m on HLE pumps and 135-175 N•m on ATE and ALE pumps.
12. Adjust the pump end clearance as described in "**THRUST BEARING ADJUSTMENT**" on page 6.
13. Lubricate the grease fitting with multi-purpose grease, NLGI #2.



## DANGER !

Before starting the pump, be sure all drive equipment guards are in place.

Failure to properly mount guards may result in serious injury or death.

## MECHANICAL SEAL

For disassembly, see “DISASSEMBLY” on page 4.

For assembly, see “ASSEMBLY” on page 4.

**NOTE:** Never touch the mechanical seal faces with anything except clean hands or a clean cloth. Minute particles can scratch the seal faces and cause leakage.

Always clean the rotor and shaft and seal housing bore before installing the mechanical seal. Make sure surfaces are clean and free of scratches.

There are two available mechanical seals. The standard features a cup type seat. A “pin style” seal is also available that has the seal seat pinned to prevent rotation. This design is used for viscosities higher than 750 cPs.

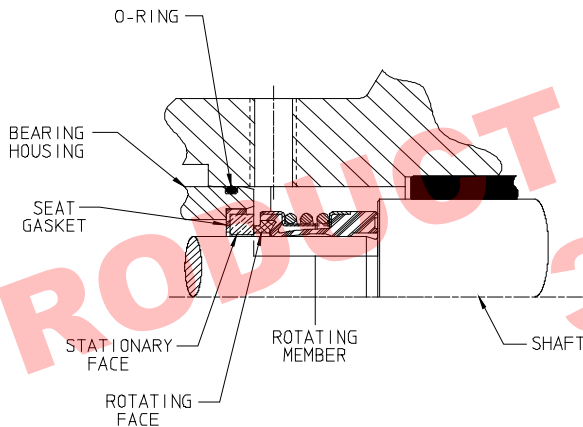

FIGURE 7

## THRUST BEARING ADJUSTMENT

See FIGURE 4 on page 3.

1. Loosen the two setscrews in the outer face of the bearing housing and turn the thrust bearing assembly clockwise until it can no longer be turned by hand. Back off counterclockwise until the rotor shaft can be turned by hand with a slight, noticeable drag.
2. For standard end clearance, back off the thrust bearing assembly the required length as measured on the outside diameter of the bearing housing (See Table 3).
3. Tighten the two self locking type “Allen” setscrews in the outboard face of the bearing housing. Tighten each with equal force against the bracket. The pump is now set with standard end clearance.

**NOTE:** Be sure the shaft rotates freely. If it doesn't, repeat the above procedure.

4. High viscosity liquids require additional end clearances. The amount of extra clearance depends on the viscosity of the liquid pumped. For specific recommendations, consult the factory. Table 3 shows the bearing housing adjustment required for additional end clearance as well as values for standard end clearance.

PUMP SIZE	STANDARD END CLEARANCE (mm)	LENGTH ON OD* (mm) FOR	
		STD.	EACH .025 mm ADDITIONAL
HLE	.08	12	4
ATE	.08	15	5
ALE	.08	15	5

\* Turn bearing housing CCW this distance to obtain either standard or additional end clearance.

TABLE 3

## INSTALLATION OF CARBON GRAPHITE BUSHINGS

When installing Carbon graphite bushings, extreme care must be taken to prevent breaking. Carbon graphite is a brittle material and cracks easily. If cracked, the bushing will quickly disintegrate. Using a lubricant on the bushing and the mating part will help in installation. The additional precautions listed below must be followed for proper installation:

1. A press must be used for installation.
2. Be certain the bushing is straight.
3. Do not stop the pressing operation until the bushing is in the proper position, starting and stopping will result in a cracked bushing.
4. Check the bushing for cracks after installation.

## INSTALLATION OF FOOT

Series 4176 pumps come equipped with a removable foot. Removal of the foot is not normally required for maintenance. In cases where the foot needs to be replaced or is being added, use the following steps.

1. Ensure alignment pins are installed in the top of the foot prior to assembly of the foot to the casing.
2. Match the foot to the casing by inserting pins into the bottom of the casing.
3. Secure foot to casing using the socket head capscrews and lock washers. Torque capscrews to 100-110 N•m.

# PRESSURE RELIEF VALVE INSTRUCTIONS

## DANGER !

Before opening any Viking pump liquid chamber (pumping chamber, reservoir, relief valve adjusting cap fitting, etc.) Be sure:

1. That any pressure in the chamber has been completely vented through the suction or discharge lines or other appropriate openings or connections.
2. That the driving means (motor, turbine, engine, etc.) has been "locked out" or made non-operational so that it cannot be started while work is being done on pump.
3. That you know what liquid the pump has been handling and the precautions necessary to safely handle the liquid. Obtain a material safety data sheet (MSDS) for the liquid to be sure these precautions are understood.

Failure to follow above listed precautionary measures may result in serious injury or death.

## RELIEF VALVE PRESSURE ADJUSTMENT:

If a new spring is installed or if the pressure setting of the pressure relief valve is changed from what the factory has set, the following instructions must be carefully followed.

1. Carefully remove the valve cap that covers the adjusting screw. **Note** this cap will most likely contain liquid.
2. Loosen the locknut that keeps the adjusting screw from turning while the pump is in operation.
3. Install a pressure gauge in the discharge line. This will be required for the pressure adjustment operation.
4. Turn the adjusting screw in to increase the pressure and out to decrease the pressure.
5. With the discharge line closed at a point beyond the pressure gauge, the gauge will show the maximum pressure that the valve will allow while the pump is in operation

## IMPORTANT

When ordering parts for a pressure relief valve, always give the model number and serial number of the pump as it appears on the nameplate. Also specify the name of the part(s) wanted. When ordering springs, be sure to give the pressure settings desired.

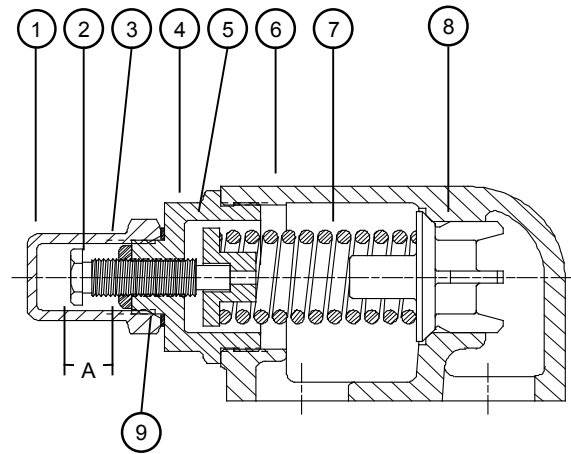

FIGURE 8  
SIZE HLE

### VALVE - LIST OF PARTS

- |                    |                 |
|--------------------|-----------------|
| 1. Valve Cap       | 6. Valve Body   |
| 2. Adjusting Screw | 7. Valve Spring |
| 3. Lock Nut        | 8. Poppet       |
| 4. Bonnet          | 9. Cap Gasket   |
| 5. Spring Guide    |                 |

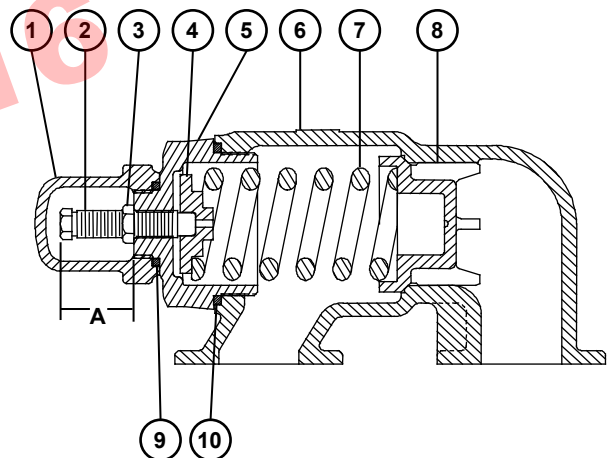

FIGURE 9  
SIZES ATE & ALE

### VALVE - LIST OF PARTS

- |                    |                   |
|--------------------|-------------------|
| 1. Valve Cap       | 6. Valve Body     |
| 2. Adjusting Screw | 7. Valve Spring   |
| 3. Lock Nut        | 8. Poppet         |
| 4. Spring Guide    | 9. Cap Gasket     |
| 5. Bonnet          | 10. Bonnet Gasket |



# TECHNICAL SERVICE MANUAL

INDUSTRIAL HEAVY DUTY MOTOR SPEED PUMPS  
SERIES 4076 AND 4176  
SIZES HLE, ATE AND ALE

SECTION	TSM 710.1
PAGE	8 OF 8
ISSUE	C



## WARRANTY

Viking warrants all products manufactured by it to be free from defects in workmanship or material for a period of one (1) year from date of startup, provided that in no event shall this warranty extend more than eighteen (18) months from the date of shipment from Viking. The warranty period for Universal Seal series pumps ONLY (Universal Seal models listed below) is three (3) years from date of startup, provided that in no event shall this warranty extend more than forty-two (42) months from the date of shipment from Viking.

UNDER NO CIRCUMSTANCES SHALL VIKING BE LIABLE UNDER THIS WARRANTY OR OTHERWISE FOR SPECIAL, INCIDENTAL, INDIRECT, CONSEQUENTIAL OR PUNITIVE DAMAGES OF ANY KIND, INCLUDING, BUT NOT LIMITED TO, LOSS OR UNREALIZED SALES, REVENUES, PROFITS, INCOME, COST SAVINGS OR BUSINESS, LOSS OR UNREALIZED CONTRACTS, LOSS OF GOODWILL, DAMAGE TO REPUTATION, LOSS OF PROPERTY, LOSS OF INFORMATION OR DATA, LOSS OF PRODUCTION, DOWNTIME, OR INCREASED COSTS, IN CONNECTION WITH ANY PRODUCT, EVEN IF VIKING HAS BEEN ADVISED OR PLACED ON NOTICE OF THE POSSIBILITY OF SUCH DAMAGES AND NOTWITHSTANDING THE FAILURE OF ANY ESSENTIAL PURPOSE OF ANY PRODUCT.

THIS WARRANTY IS AND SHALL BE VIKING'S SOLE AND EXCLUSIVE WARRANTY AND SHALL BE IN LIEU OF ALL OTHER WARRANTIES, EXPRESS OR IMPLIED, INCLUDING, BUT NOT LIMITED TO, ALL WARRANTIES OF MERCHANTABILITY, FITNESS FOR A PARTICULAR PURPOSE AND NON-INFRINGEMENT ALL OF WHICH OTHER WARRANTIES ARE EXPRESSLY EXCLUDED.

See complete warranty at [www.vikingpump.com](http://www.vikingpump.com).