



TECHNICAL SERVICE MANUAL

HEAVY-DUTY BRACKET MOUNTED PUMPS
 SERIES 125 AND 4125
 SIZES LS, Q, QS, M

SECTION	TSM 141.2
PAGE	1 OF 12
ISSUE	F

CONTENTS

Introduction	1
Special Information	2
Maintenance	2
Packed Pumps	3
Mechanical Seal Pumps	6
Standard Rubber Bellows Type	8
Optional PTFE Seal	9
Thrust Bearing Adjustment	10
Installation of Carbon Graphite Bushings	11
Pressure Relief Valve Instructions	11



FIGURE 1
Size LS

INTRODUCTION

The illustrations used in this manual are for identification purposes only and cannot be used for ordering parts. Obtain a parts list from the factory or a Viking® representative. Always give complete name of part, part number and material with model number and serial number of pump when ordering repair parts. The unmounted pump or pump unit model number and serial number are on the nameplate.

In the Viking model number system, basic size letters are combined with series number (125 and 4125) and used to indicate either an unmounted pump or mounted pump unit.

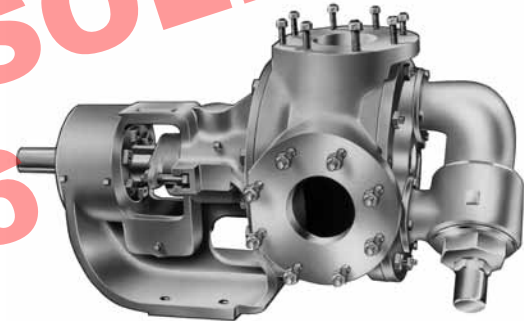

FIGURE 2
Sizes Q and M

UNMOUNTED PUMP		UNITS
PACKED	MECH. SEAL	
LS125	LS4125	Units are designated by the unmounted pump model numbers followed by a letter indicating drive style. V = V-belt D = Direct Connected R = Viking Speed Reducer P = Commercial Speed Reducer
Q125	Q4125	
QS125	QS4125	
M125	M4125	



FIGURE 3
Size QS

This manual deals only with Series 125 and 4125 Heavy Duty Bracket Mounted Pumps. Refer to Figures 1 through 15 for general configuration and nomenclature used in this manual. Pump specifications and recommendations are listed in Catalog Section 141, Series 125 and 4125 Heavy Duty Bracket Mounted Pumps.

SPECIAL INFORMATION

DANGER !

Before opening any Viking pump liquid chamber (pumping chamber, reservoir, relief valve adjusting cap fitting, etc.)

Be sure:

1. That any pressure in the chamber has been completely vented through the suction or discharge lines or other appropriate openings or connections.
2. That the driving means (motor, turbine, engine, etc.) has been "locked out" or made non-operational so that it cannot be started while work is being done on pump.
3. That you know what liquid the pump has been handling and the precautions necessary to safely handle the liquid. Obtain a material safety data sheet (MSDS) for the liquid to be sure these precautions are understood.

Failure to follow above listed precautionary measures may result in serious injury or death.

ROTATION: Viking pumps operate equally well in a clockwise or counterclockwise rotation. Shaft rotation determines which port is suction and which is discharge. Port in area where pumping elements (gear teeth) come out of mesh is suction port.

PRESSURE RELIEF VALVES:

1. Viking pumps are positive displacement pumps and must be provided with some sort of pressure protection. This may be a relief valve mounted directly on the pump, an inline pressure relief valve, a torque limiting device or a rupture disk.
2. There are relief valve options available on those pump models designed to accept a relief valve. Options may include a return to tank relief valve and a jacketed relief valve. Pumps equipped with a jacketed head plate are generally not available with a relief valve.
3. If pump rotation is reversed during operation, pressure protection must be provided on **both** sides of pump.
4. Relief valve adjusting screw cap must **always** point towards suction side of pump. If pump rotation is reversed, remove pressure relief valve and turn end for end. **Refer to Figures 1 and 2.**
5. Pressure relief valves cannot be used to control pump flow or regulate discharge pressure.

For additional information on pressure relief valves, **Refer to Technical Service Manual TSM000 and Engineering Service Bulletin ESB-31.**

SPECIAL MECHANICAL SEALS

Extra care must be taken in repair of pumps with mechanical seals. Read and follow all special information supplied with pump.

MAINTENANCE

Series 125 and 4125 pumps are designed for long, trouble-free service life under a wide variety of application conditions with a minimum of maintenance. The points listed below will help provide long service life.

LUBRICATION: External lubrication must be applied slowly with a hand gun to all lubrication fittings every 500 hours of operation with multi-purpose grease, NLGI #2. Do not over-grease. Applications involving very high or low temperatures will require other types of lubrication. **Refer to Engineering Service Bulletin ESB-515.** Consult factory with specific lubrication questions.

PACKING ADJUSTMENT: New packed pumps require initial packing adjustment to control leakage as packing "runs in". Make initial adjustments carefully and do not over-tighten packing gland. After initial adjustment, inspection will reveal need for packing gland adjustment or packing replacement. **Refer to instructions under Disassembly, page 4, and Assembly, page 5,** regarding repacking pump.

CLEANING PUMP: Keep pump as clean as possible. This will facilitate inspection, adjustment and repair work and help prevent overlooking a dirt covered grease fitting.

STORAGE: If pump is to be stored, or not used for six months or more, pump must be drained and a light coat of non-detergent SAE 30 weight oil must be applied to all internal pump parts. Lubricate fittings and apply grease to pump shaft extension. Viking suggests rotating pump shaft by hand one complete revolution every 30 days to circulate the oil.

SUGGESTED REPAIR TOOLS: The following tools must be available to properly repair Series 125 and 4125 pumps. These tools are in addition to standard mechanics' tools such as open end wrenches, pliers, screw drivers, etc. Most of the items can be obtained from an industrial supply house.

1. Soft Headed hammer
2. Allen wrenches (some mechanical seals and set collars)
3. Packing hooks, flexible (packed pumps)
Large for 0.38 inch and up cross section packing
4. Mechanical seal installation sleeve
Viking Part No. 2-751-005-630 for 2.44 inch seal;
Q, QS & M4125
5. Bearing locknut spanner wrench
6. Spanner wrench, adjustable pin type for use on double end caps
7. Brass bar
8. Arbor press

PACKED PUMPS

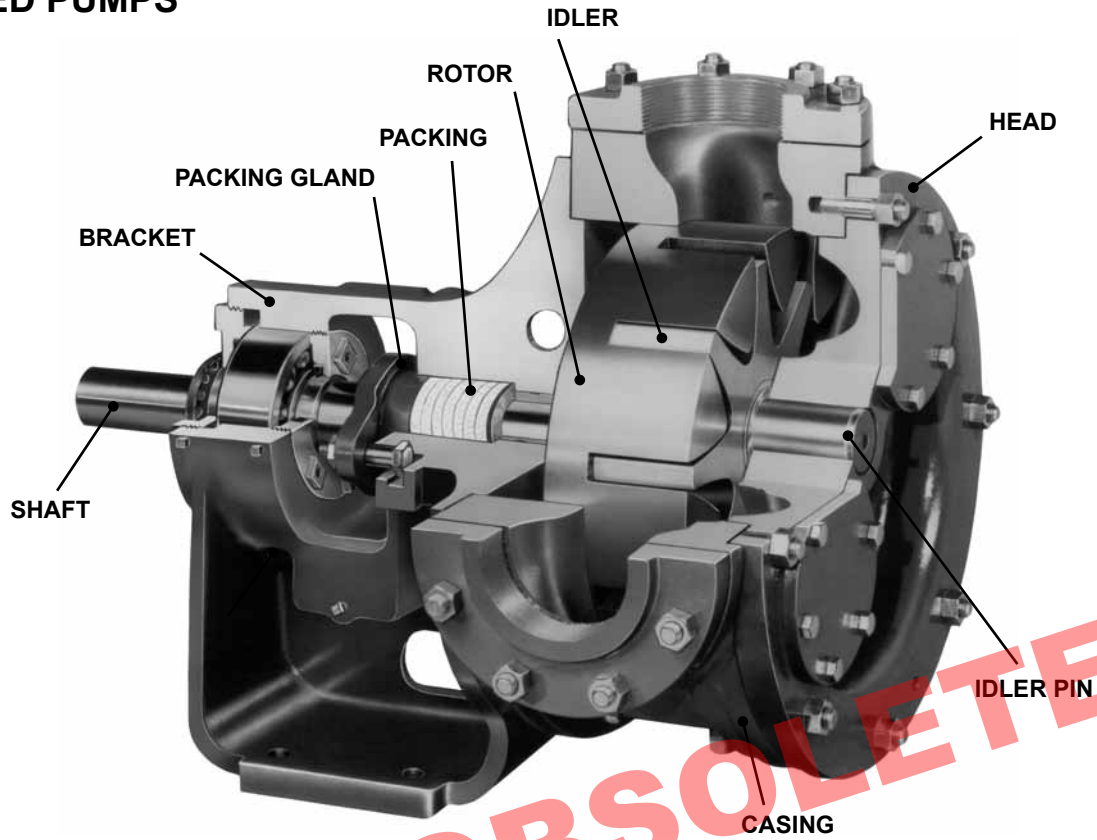
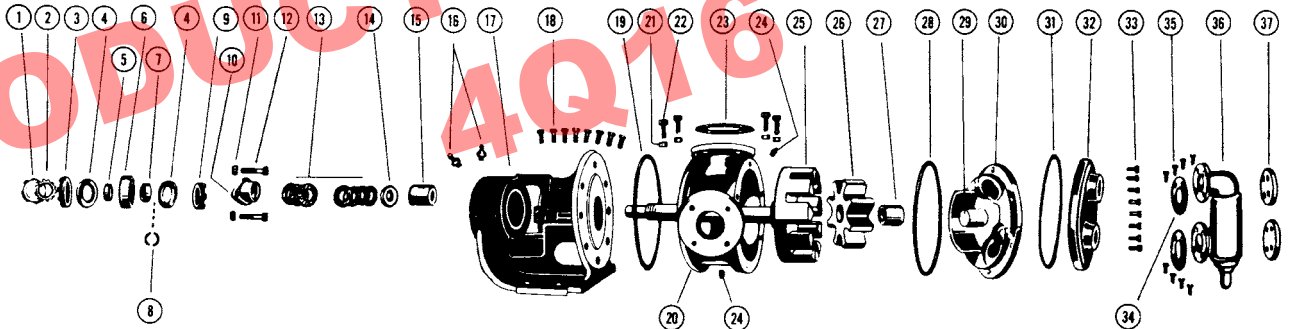
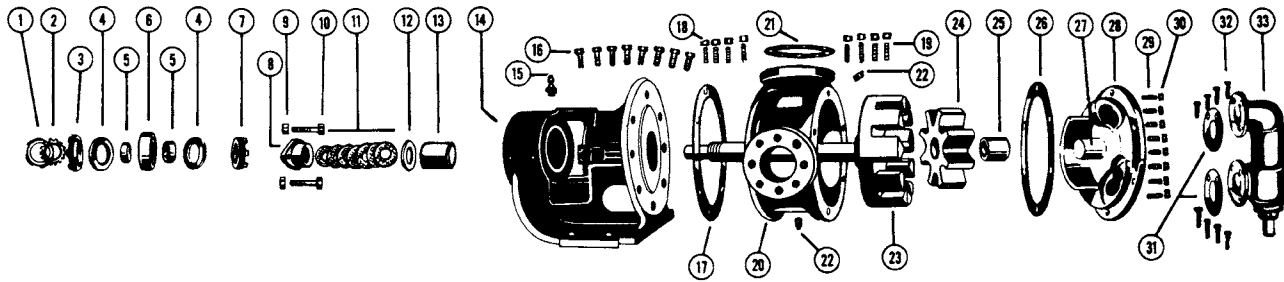

FIGURE 4
CUTAWAY VIEW OF PACKED PUMP MODEL Q OR M125 WITH CALLOUTS



EXPLODED VIEW OF MODEL LS125

ITEM	NAME OF PART	ITEM	NAME OF PART	ITEM	NAME OF PART
1	Locknut	14	Packing Retainer Washer	27	Idler Bushing
2	Lockwasher	15	Bracket Bushing	28	Head Gasket
3	End Cap (Outer)	16	Grease Fitting	29	Idler Pin
4	Lip Seal for End Cap	17	Bracket and Bushing	30	Head and Idler Pin
5	Bearing Spacer Collar (Outer)	18	Capscrew for Bracket	31	Gasket for Jacket Head Plate
6	Ball Bearing	19	Bracket Gasket	32	Jacket Head Plate
7	Bearing Spacer Collar (Inner)	20	Casing	33	Capscrew for Head
8	Ring, Half Round	21	Nut for Flanges	34	Relief Valve Gasket
9	End Cap (Inner)	22	Capscrew for Flanges	35	Capscrew for Relief Valve
10	Packing Gland	23	Pipe Flange Gasket	36	Internal Relief Valve
11	Packing Gland Nut	24	Pipe Plug	37	Cover Plate, Relief Valve
12	Packing Gland Capscrew	25	Rotor and Shaft		
13	Packing	26	Idler and Bushing		



EXPLODED VIEW FOR MODELS SQ, QS AND M125

ITEM	NAME OF PART	ITEM	NAME OF PART	ITEM	NAME OF PART
1	Locknut	13	Bracket Bushing	25	Idler Bushing
2	Lockwasher	14	Bracket and Bushing	26	Head Gasket
3	End Cap (Outer)	15	Grease Fitting	27	Idler Pin
4	Lip Seal for End Cap	16	Capscrew for Bracket	28	Head and Idler Pin
5	Bearing Spacer Collar	17	Bracket Gasket	29	Stud for Head
6	Ball Bearing	18	Nut for Flanges	30	Nut for Head
7	End Cap (Inner)	19	Stud for Flanges	31	Relief Valve Gasket
8	Packing Gland	20	Casing (QS size has opposite ports)	32	Capscrew for Relief Valve
9	Packing Gland Nut	21	Pipe Flange Gasket	33	Internal Relief Valve
10	Packing Gland Capscrew	22	Pipe Plug		Suckback Line, Not Illustrated
11	Packing	23	Rotor and Shaft		
12	Packing Retainer Washer	24	Idler and Bushing		

DISASSEMBLY

DANGER!

Before opening any Viking pump liquid chamber (pumping chamber, reservoir, relief valve adjusting cap fitting, etc.) Be sure:

1. That any pressure in the chamber has been completely vented through the suction or discharge lines or other appropriate openings or connections.
2. That the driving means (motor, turbine, engine, etc.) has been "locked out" or made non-operational so that it cannot be started while work is being done on pump.
3. That you know what liquid the pump has been handling and the precautions necessary to safely handle the liquid. Obtain a material safety data sheet (MSDS) for the liquid to be sure these precautions are understood.

Failure to follow above listed precautionary measures may result in serious injury or death.

1. Mark head and casing before disassembly to insure proper reassembly. The idler pin, which is offset in pump head, must be positioned toward and equal distance between port connections to allow for proper flow of liquid through pump.

Remove head from pump. **Do not allow idler to fall from idler pin.** Tilt top of head back when removing to prevent this. Avoid damaging head gasket. If pump is furnished with pressure relief valve, it need not be removed from head or disassembled at this point. Refer to Pressure Relief Valve Instructions, page 11.

If LS pump has jacketed head plate, it will separate from head when it is removed. The gasket between head and jacket head plate must be totally removed. Use new gasket when assembling pump.

2. Remove idler and bushing assembly.
3. Insert length of hardwood or brass through port opening between rotor teeth to keep shaft from turning. Bend up tang of lockwasher and with a spanner wrench remove locknut and lockwasher from shaft.
4. Remove packing gland nuts.
5. Tap shaft forward approximately 0.5 inch and remove pair of half round rings under inner bearing spacer collar.
6. Carefully remove rotor and shaft to avoid damaging bracket bushing.
7. Remove packing gland from side of bracket.
8. Loosen four setscrews over the inner and outer end caps. Remove both end caps with lip seals, spacer collars and ball bearing. Refer to Figure 5, page 11.

The inner cap can be removed through side opening of the bracket.

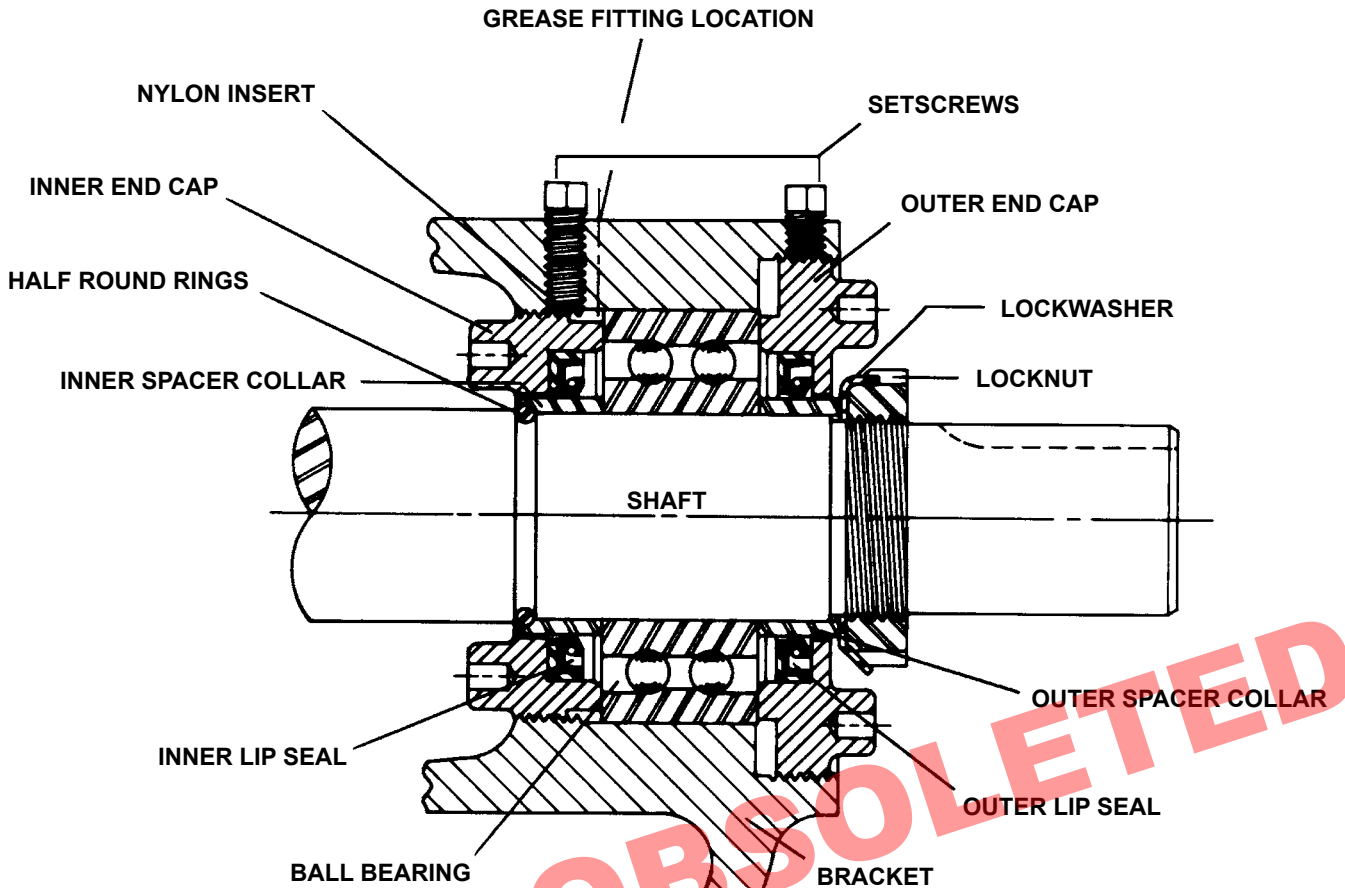

FIGURE 5

9. Remove packing and packing retainer washer.
10. Clean all parts thoroughly and examine for wear and damage. Check lip seals, ball bearing, bushings and idler pin and replace if necessary. Check all other parts for nicks, burrs, excessive wear and replace if necessary.

Wash bearings in clean solvent. Blow out bearings with compressed air. Do not allow bearings to spin; turn them slowly by hand. Spinning bearings will damage race and balls. Make sure bearings are clean, then lubricate with non-detergent SAE 30 weight oil and check for roughness. Roughness can be determined by turning outer race by hand.

If bearings have roughness, bearings will need to be replaced.

11. Casing can be checked for wear or damage while mounted on bracket.

ASSEMBLY

1. Install bracket bushing. If bracket bushing has a lubrication groove, install bushing with groove at 6:00 o'clock position in bracket. If carbon graphite, **Refer to Installation of Carbon Graphite Bushings, page 11.**
2. Coat shaft of rotor shaft assembly with non-detergent SAE 30 weight oil. Start end of shaft in bracket bushing turning from right to left, slowly pushing rotor in casing.

3. Place packing retainer washer in bottom of packing chamber and pack pump with new packing. Use packing suitable for liquid being pumped. Install packing, staggering the joints from one side of shaft to other. Lubricate packing rings with oil, grease or graphite to aid assembly. A length of pipe will help to seat each packing ring.
4. Install packing gland, capscrews and nuts. Back rotor and shaft out of casing just far enough to insert packing gland through side opening of bracket over end of shaft. Make sure gland is installed square and nuts are tightened evenly. Tighten nuts wrench tight then back off until gland is slightly loose.
5. Coat idler pin with non-detergent SAE 30 weight oil and place idler and bushing on idler pin in head. If replacing with carbon graphite bushing, **Refer to Installation of Carbon Graphite Bushings, page 11.**
6. Using a .010 to .015 inch head gasket, install head and idler assembly on pump. Pump head and casing were marked before disassembly to insure proper reassembly. If not, be sure idler pin, which is offset in pump head, is positioned toward and equal distance between port connections to allow for proper flow of liquid through pump.

If pump is equipped with jacketed head plate, install at this time along with new gasket.

Tighten head capscrews evenly.

If pump was equipped with a relief valve and it was removed during disassembly, install on head with new gaskets. Relief valve adjusting screw cap must always point toward suction port. **Refer to Figures 1, 2 and 3 on page 1.** For relief valve repair or adjustments, **Refer to Pressure Relief Valve Instructions, Page 11.**

- Slide inner spacer collar over shaft with recessed end facing rotor. Q, QS and M size bearing spacer collars are not recessed.

Place pair of half round rings on shaft and slide inner bearing spacer collar over half round rings to lock them in place. There is no pair of half round rings on Q, QS and M size pumps. **Refer to Figure 5, page 5.**

- Press lip seal, lip facing end of shaft, in inner end cap and insert end cap through shaft end of bracket. Turn end cap clockwise, looking at shaft end, until it engages threads. End cap spanner wrench holes must be facing rotor. Turn end cap with spanner wrench until it projects slightly from opening on side of bracket. End cap must not be turned so far that lip seal drops off end of spacer collar on shaft or end cap becomes disengaged from threads. **Refer to Figure 5, page 5.**

If this happens, remove inner spacer collar, half round rings and end cap and start over at Step 7.

- Pack ball bearing with multi-purpose grease, NLGI #2. Place on shaft and push or gently drive in place in bracket.
- Press lip seal, lip facing end of shaft, in outer end cap and insert end cap in bracket. Turn end cap in bracket until it is tight against bearing. **Refer to Figure 5, page 5.**
- Put lockwasher and locknut on shaft. Insert length of hardwood or brass through port opening between rotor teeth to keep shaft from turning. Tighten locknut to 120-150 ft.-lbs. Torque (LS) or 170-190 ft.-lbs. Torque (Q, QS, M). Bend one tang of lockwasher into slot of locknut. If tang does not line up with slot, tighten locknut until it does. Failure to tighten locknut or engage lockwasher tang could result in early bearing failure and cause damage to rest of pump.

Remove length of hardwood or brass from port opening.

- Adjust pump end clearance. **Refer to Thrust Bearing Adjustment, page 10.**
- Lubricate all grease fittings with multi-purpose grease, NLGI #2.

DANGER !

Before starting pump, be sure all drive equipment guards are in place.

Failure to properly mount guards may result in serious injury or death.

MECHANICAL SEAL PUMPS

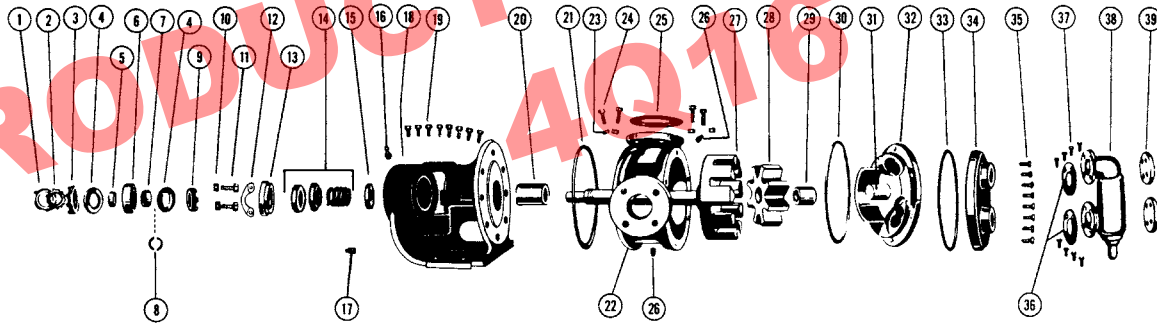

EXPLODED VIEW FOR MODEL LS4125

ITEM	NAME OF PART	ITEM	NAME OF PART	ITEM	NAME OF PART
1	Locknut	14	Mechanical Seal	27	Rotor and Shaft
2	Lockwasher	15	Set Collar	28	Idler and Bushing
3	End Cap (Outer)	16	Grease Fitting	29	Idler Bushing
4	Lip Seal for End Cap	17	Pipe Plug	30	Head Gasket
5	Bearing Spacer Collar (Outer)	18	Bracket and Bushing	31	Idler Pin
6	Ball Bearing	19	Capscrew for Bracket	32	Head and Idler Pin
7	Bearing Spacer Collar (Inner)	20	Bracket Bushing	33	Gasket for Jacket Head Plate
8	Ring, Half Round	21	Bracket Gasket	34	Jacket Head Plate
9	End Cap (Inner)	22	Casing	35	Capscrew for Head
10	Nut for Seal Holder	23	Nut for Flanges	36	Relief Valve Gasket
11	Capscrew for Seal Plate	24	Capscrew for Flanges	37	Capscrew for Relief Valve
12	Seal Plate	25	Pipe Flange Gasket	38	Internal Relief Valve
13	Seal Holder	26	Pipe Plug	39	Cover Plate, Relief Valve

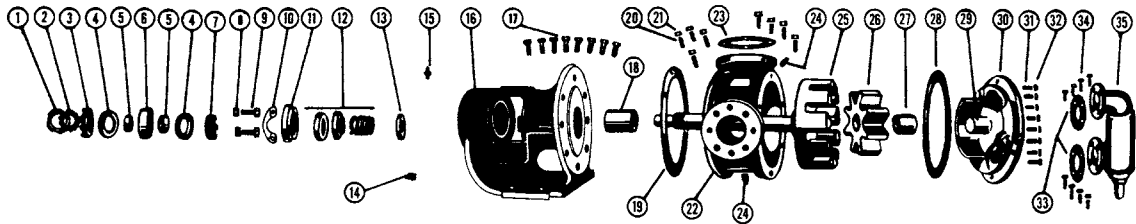

EXPLODED VIEW FOR MODELS Q, QS AND M125

ITEM	NAME OF PART	ITEM	NAME OF PART	ITEM	NAME OF PART
1	Locknut	13	Set Collars	25	Rotor and Shaft
2	Lockwasher	14	Pipe Plug	26	Idler and Bushing
3	End Cap (Outer)	15	Grease Fitting	27	Idler Bushing
4	Lip Seal for End Cap	16	Bracket and Bushing	28	Head Gasket
5	Bearing Spacer Collar	17	Capscrew for Bracket	29	Idler Pin
6	Ball Bearing	18	Bracket Bushing	30	Head and Idler Pin
7	End Cap (Inner)	19	Bracket Gasket	31	Stud for Head
8	Nut for Seal Holder	20	Stud for Flanges	32	Nut for Head
9	Capscrew for Seal Holder	21	Nut for Flanges	33	Relief Valve Gasket
10	Seal Holder Plate	22	Casing (QS size has opposite ports)	34	Capscrew for Relief Valve
11	Seal Holder	23	Pipe Flange Gasket	35	Internal Relief Valve
12	Mechanical Seal	24	Pipe Plug		Suckback Line, Not Illustrated

DISASSEMBLY

DANGER !

Before opening any Viking pump liquid chamber (pumping chamber, reservoir, relief valve adjusting cap fitting, etc.) Be sure:

1. That any pressure in the chamber has been completely vented through the suction or discharge lines or other appropriate openings or connections.
2. That the driving means (motor, turbine, engine, etc.) has been "locked out" or made non-operational so that it cannot be started while work is being done on pump.
3. That you know what liquid the pump has been handling and the precautions necessary to safely handle the liquid. Obtain a material safety data sheet (MSDS) for the liquid to be sure these precautions are understood.

Failure to follow above listed precautionary measures may result in serious injury or death.

1. Mark head and casing before disassembly to insure proper reassembly. The idler pin, which is offset in pump head, must be positioned toward and equal distance between port connections to allow for proper flow of liquid through pump.

Remove head from pump. **Do not allow idler to fall from idler pin.** Tilt top of head back when removing to prevent this. Avoid damaging head gasket. If pump is furnished with pressure relief valve, it need not be removed from head or disassembled at this point. Refer to Pressure Relief Valve Instructions, page 11.

If LS pump has jacketed head plate, it will separate from head when it is removed. The gasket between head and jacket head plate must be totally removed. Use new gasket when assembling pump. Q, QS and M pumps have one piece gasket.

2. Remove idler and bushing assembly.
3. Insert length of hardwood or brass through port opening between rotor teeth to keep shaft from turning. Bend up tang of lockwasher and with a spanner wrench remove locknut and lockwasher from shaft.
4. Standard Mechanical Seal (synthetic rubber bellows type) uses a set collar behind the seal spring. Two setscrews must be loosened before shaft can be removed. Access to collar setscrews is through seal access hole on right hand side of mounting bracket (viewed from shaft end, Refer to Figure 6.)
5. Tap shaft forward approximately 0.5 inch and remove pair of half round rings under inner spacer collar. There is no pair of half round rings on Q, QS and M size pumps. Refer to Figure 7.
6. Carefully remove rotor and shaft to avoid damaging bracket bushing.
7. Remove seal holder and seal holder plate.
8. The seal seat and rotary member of the seal can now be removed from the side opening of bracket.

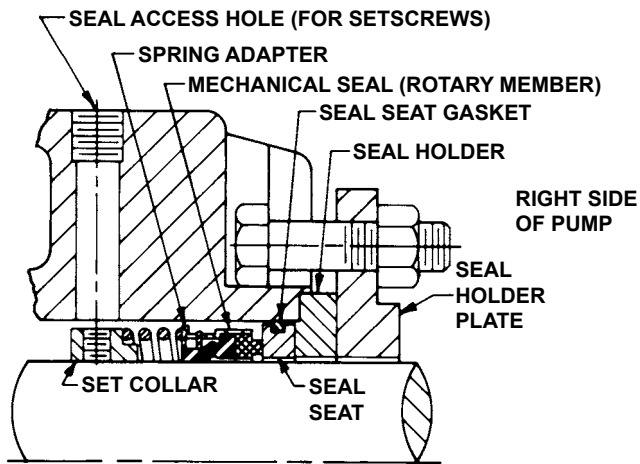

FIGURE 6 - STANDARD MECHANICAL SEAL

ASSEMBLY

Standard Mechanical Seal (Synthetic Rubber Bellows Type)

The seal used in this pump is simple to install and good performance will result if care is taken during installation.

The principle of the mechanical seal is contact between the rotary and stationary members. These parts are lapped to a high finish and their sealing effectiveness depends on complete contact.

Viking furnishes a number of heavy-duty pumps with special mechanical seals installed in the packing end of the pump. These special seals are not discussed in **TSM141.2**. Information is available by contacting the factory. When requesting special seal information, be sure to give pump model number and serial number.

1. Install bracket bushing. If bracket bushing has a lubrication groove, install bushing with groove at 6:00 o'clock position in bracket. If carbon graphite, **Refer to Installation of Carbon Graphite Bushings, page 11.**

2. Coat rotor shaft with non-detergent SAE 30 weight oil. Start end of shaft in bracket bushing and turn from right to left, slowly pushing until the ends of the rotor teeth are just below the face of the casing.

3. Using a .015 inch head gasket, install head and idler assembly on pump. Pump head and casing were marked before disassembly to insure proper reassembly. If not, be sure idler pin, which is offset in pump head, is positioned toward and equal distance between port connections to allow for proper flow of liquid through pump.

If pump is equipped with jacketed head plate, install at this time along with new gasket.

Tighten head capscrews evenly.

If pump was equipped with a relief valve and it was removed during disassembly, install a head with new gaskets. Relief valve adjusting screw cap must always point toward suction port. **Refer to Figures 1, 2 and 3** on page 1. For relief valve repair or adjustments, **Refer to Pressure Relief Valve Instructions, page 11.**

4. Clean rotor shaft and bracket seal housing bore. Be sure they are free of dirt, grit and scratches. Gently radius leading edge of shaft diameter over which seal must be placed.

5. Install seal set collar. Examine set collar for burrs or scratches, and setscrews are withdrawn to prevent shaft from being scratched when set collar is installed. Place set collar onto shaft, push into seal chamber until centerline of setscrews coincides with centerline of tapped seal access holes on right side of bracket (viewed from shaft end).

Tighten all setscrews securely to shaft. **Refer to Figure 8.**

6. Sealing faces on mechanical seals should not be touched with anything but fingers or a clean cloth. A tapered sleeve is available, at extra cost, for Q, QS and M pumps from Viking Pump for seal installation on shaft. **Refer to Figure 9.**

LS pump shaft is tapered and an installation sleeve is not available.

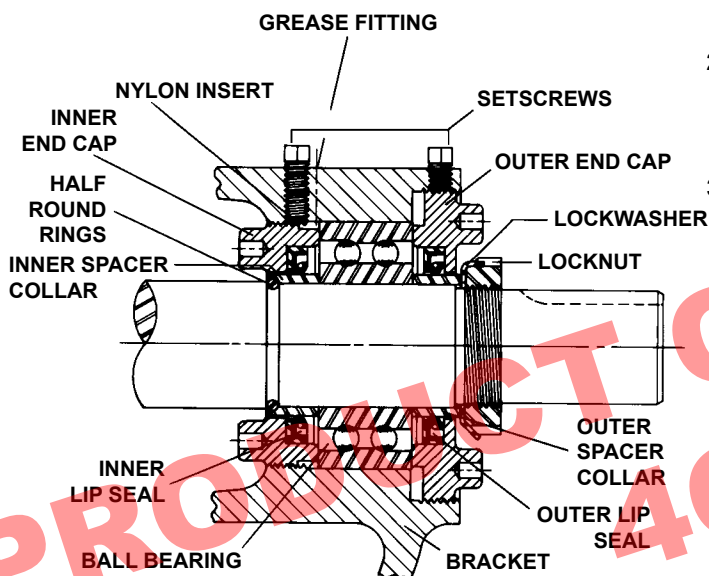

FIGURE 7

9. Loosen the four setscrews over the outer and inner end caps. Remove both end caps, spacer collars and ball bearing. **Refer to Figure 7.** The inner end cap can be removed through the side openings in the bracket.

10. Clean all parts thoroughly and examine for wear or damage. Check lip seals, ball bearing, bushing and idler pin and replace if necessary. Check all other parts for nicks, burrs, excessive wear and replace if necessary.

Wash bearings in clean solvent. Blow out bearings with compressed air. Do not allow bearings to spin; turn them slowly by hand. Spinning bearings will damage race and balls. Make sure bearings are clean, then lubricate with non-detergent SAE 30 weight oil and check for roughness. Roughness can be determined by turning outer race by hand.

Be sure shaft is free from nicks, burrs and foreign particles that might damage bracket bushing. Scratches on shaft in seal area will provide leakage paths under mechanical seal.

11. Casing can be checked for wear or damage while mounted on bracket.

RIGHT SIDE
OF PUMP

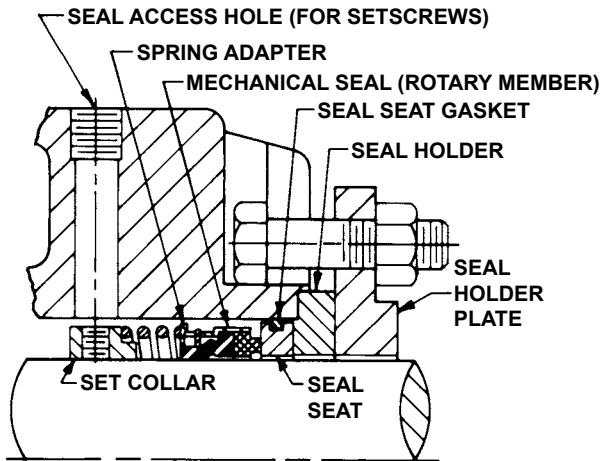

FIGURE 8 - STANDARD MECHANICAL SEAL

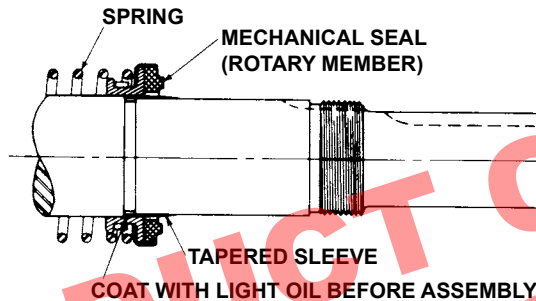

FIGURE 9

7. Install rotating member of seal. Slide spring over shaft into seal chamber and onto set collar pilot. Center spring adapter (Q, QS and M size only) against back of metal retainer so spring will push against adapter and not work itself over back of mechanical seal. Place tapered sleeve on shaft. **Refer to Figure 9.** Apply a liberal coating of SAE-30 non-detergent oil to large diameter portion of shaft, tapered sleeve and to inside diameter of seal rubber parts. Start rotary member, carbon face out, onto shaft and push along shaft until spring is centered against adapter.

Install Stationary Seal Seat. Lubricate outside diameter of seal o-ring seat gasket and flush lapped face with lube oil. Press stationary seat into bore until lapped face is just inside bore. Position stationary seat by installing seal holder and secure to machined face of bracket with seal holder plate. Tighten nuts securing seal holder evenly so seal holder will not be distorted. **Refer to Figure 8.**

Remove tapered installation sleeve.

8. Slide inner spacer collar over shaft with recessed end facing rotor. Q, QS and M size bearing spacer collars are not recessed.

Place pair of half round rings on shaft and slide inner bearing spacer collar over half round rings to lock them in place. There is no pair of half round rings on Q, QS and M size pumps. **Refer to Figure 7, page 8.**

9. Press lip seal, lip facing end of shaft, in inner end cap and insert end cap through shaft end of bracket. Turn end cap clockwise, looking at shaft end, until it engages threads. End cap spanner wrench holes must be facing rotor. Turn end cap with spanner wrench until it projects slightly from opening on side of bracket. End cap must not be turned so far that lip seal drops off end of spacer collar on shaft or end cap becomes disengaged from threads. **Refer to Figure 7, page 8.**

If this happens, remove inner spacer collar, half round rings and end cap and start over at Step 8.

10. Pack ball bearing with multi-purpose grease, NLGI #2. Place on shaft and push or gently drive in place in bracket.
11. Press lip seal, lip facing end of shaft, in outer end cap and insert end cap in bracket. Turn end cap in bracket until it is tight against bearing. **Refer to Figure 7, page 8.**
12. Put lockwasher and locknut on shaft. Insert length of hardwood or brass through port opening between rotor teeth to keep shaft from turning. Tighten locknut to 120-150 ft.- lbs. Torque (LS) or 170-190 ft.- lbs. Torque (Q, QS, M). Bend one tang of lockwasher into slot of locknut. If tang does not line up with slot, tighten locknut until it does. Failure to tighten locknut or engage lockwasher tang could result in early bearing failure and cause damage to rest of pump.

Remove length of hardwood or brass from port opening.

13. Adjust pump end clearance. **Refer to Thrust Bearing Adjustment, page 10.**
14. Lubricate all grease fittings with multi-purpose grease, NLGI #2.

DANGER !

Before starting pump, be sure all drive equipment guards are in place.

Failure to properly mount guards may result in serious injury or death.

ASSEMBLY

Optional Mechanical Seal (PTFE Fitted Type)

The seal type shown in **Figure 10, page 10** can be installed as an alternate to the standard mechanical seal (synthetic rubber bellows type). This seal is setscrew driven, is simple to install and good performance will result if care is taken during installation.

Clean rotor shaft and seal housing bore. Make sure they are free of dirt, grit and scratches. Gently radius leading edge of shaft diameter over which seal is to be placed.

A tapered sleeve is available, at extra cost, for Q, QS and M pumps from Viking Pump for seal installation on shaft. LS size pump shaft is tapered and installation sleeve is not available. Place tapered sleeve on shaft, **Refer to Figure 11.**

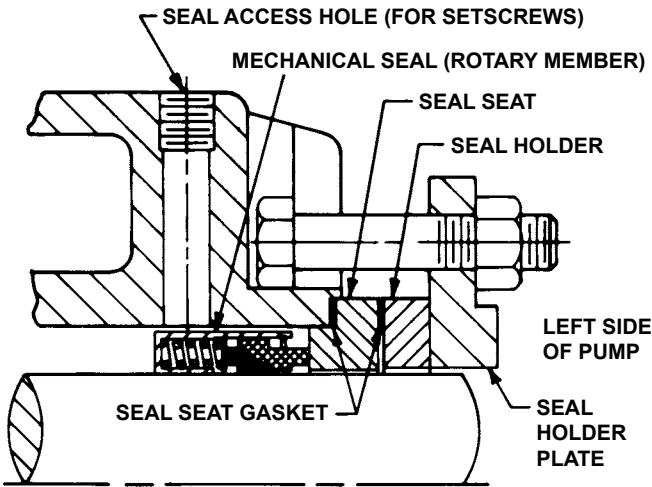

FIGURE 10 - OPTIONAL MECHANICAL SEAL

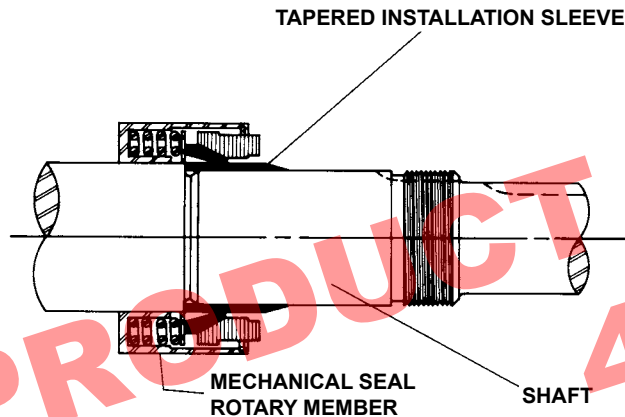

FIGURE 11

Never touch sealing faces with anything except clean hands or clean cloth. Minute particles can scratch the seal faces and cause leakage.

Coat tapered sleeve and inside of the rotary member with a generous quantity of SAE 30 non-detergent oil. Grease is not recommended. Start rotary member on shaft and over tapered sleeve.

Move rotary member so setscrews are directly below seal access holes on left side of bracket (viewed from shaft end) **Refer to Figure 10.** Tighten all setscrews securely to shaft. Flush sealing faces of both rotary member and seal seat with oil and install seal seat and seat gasket over end of shaft against machined bracket face. Assemble other seal seat gasket, seal holder, seal holder plate, capscrews and nuts and tighten securely. Remove tapered installation sleeve.

Some PTFE seals are equipped with holding clips which compress the seal springs. Remove holding clips to release springs after seal is installed on shaft.

AT THIS POINT, FINISH ASSEMBLY PROCEDURES STARTING AT STEP 8, PAGE 9 (STANDARD MECHANICAL SEAL).

THRUST BEARING ADJUSTMENT

Refer to Figure 13

1. Loosen two setscrews over each outer and inner end caps.
2. Turn inner end cap clockwise (viewed from shaft end) until it projects slightly into opening on side of bracket exposing approximately three threads.
3. Turn outer end cap clockwise until rotor is tight against head and rotor shaft cannot be turned.
4. Make a reference mark on bracket end, opposite a notch on outer end cap. Back off outer end cap required number of notches as shown in Total End Clearance Chart. **Refer to Figure 11.** Each notch represents .002" end clearance.
5. High viscosity liquids require additional end clearances. The amount of extra end clearance depends on the viscosity of the liquid pumped. For specific recommendations contact factory.
6. Tighten inner end cap with a spanner wrench. Tap spanner wrench lightly but **DO NOT OVER-TIGHTEN** as it will damage threads.
7. Tighten set screws that hold inner and outer end caps to prevent their turning in bracket.
8. Check rotor to determine if it turns freely; if it does not, add more end clearance.

TOTAL END CLEARANCE CHART		
PUMP SIZE	TURN OUTER END CAP COUNTER-CLOCKWISE NO. OF NOTCHES	TOTAL END CLEARANCE
LS	2.5	.005
Q, QS AND M	5	.010

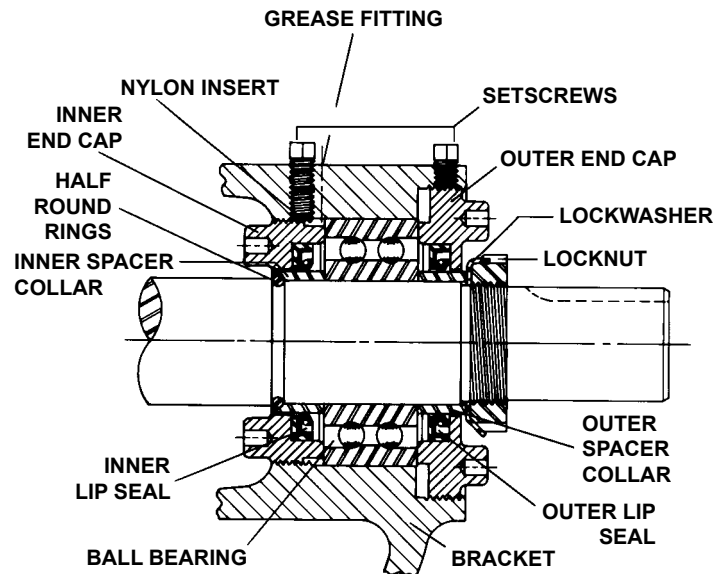

FIGURE 13

INSTALLATION OF CARBON GRAPHITE BUSHINGS

When installing carbon graphite bushings, extreme care must be taken to prevent breaking. Carbon graphite is a brittle material and easily cracked. If cracked, the bushing will quickly disintegrate. Using a lubricant and adding a chamfer on the bushing and the mating part will help in installation. The additional precautions listed below must be followed for proper installation:

1. A press must be used for installation.
2. Be certain bushing is started straight.
3. Do not stop pressing operation until bushing is in proper position. Starting and stopping will result in a cracked bushing.
4. Check bushing for cracks after installation.

Carbon graphite bushings with extra interference fits are frequently furnished for high temperature operation. These bushings must be installed by a shrink fit.

1. Heat bracket or idler to **750 °F.**
2. Install cool bushings with a press.
3. If facilities are not available to reach **750 °F.** temperature, it is possible to install with **450 °F.** temperature; however, the lower the temperature, the greater the possibility of cracking bushing.

Consult factory with specific questions on high temperature applications. Refer to Engineering Service Bulletin ESB-3.

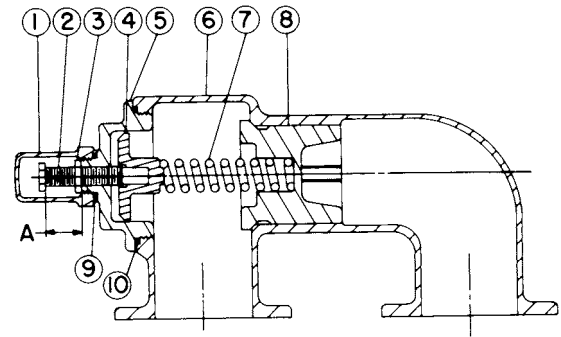

FIGURE 15
Sizes Q, QS and M

LIST OF PARTS

1. Valve Cap	6. Valve Body
2. Adjusting Screw	7. Valve Spring
3. Lock Nut	8. Poppet
4. Spring Guide	9. Cap Gasket
5. Bonnet	10. Bonnet

DISASSEMBLY

DANGER !

Before opening any Viking pump liquid chamber (pumping chamber, reservoir, relief valve adjusting cap fitting, etc.) Be sure:

1. That any pressure in the chamber has been completely vented through the suction or discharge lines or other appropriate openings or connections.
2. That the driving means (motor, turbine, engine, etc.) has been "locked out" or made non-operational so that it cannot be started while work is being done on pump.
3. That you know what liquid the pump has been handling and the precautions necessary to safely handle the liquid. Obtain a material safety data sheet (MSDS) for the liquid to be sure these precautions are understood.

Failure to follow above listed precautionary measures may result in serious injury or death.

PRESSURE RELIEF VALVE INSTRUCTIONS

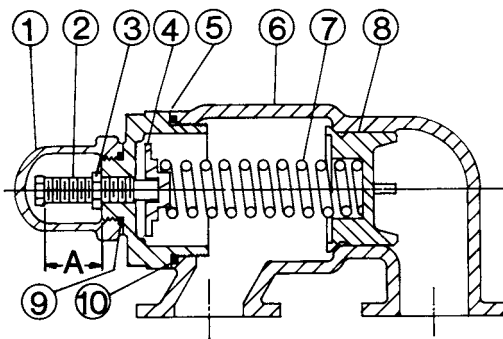

FIGURE 14
Size LS

DISASSEMBLY

Mark valve and head before disassembly to insure proper reassembly.

1. Remove valve cap.
2. Measure and record length of extension of adjusting screw. **Refer to "A" on Figures 14 and 15.**
3. Loosen locknut and back out adjusting screw until spring pressure is released.
4. Remove bonnet, spring guide, spring and poppet from valve body. Clean and inspect all parts for wear or damage and replace as necessary.

DANGER !

Before starting pump, be sure all drive equipment guards are in place.

Failure to properly mount guards may result in serious injury or death.

PRESSURE ADJUSTMENT

If a new spring is installed or if pressure setting of pressure relief valve is to be changed from that which the factory has set, the following instructions must be carefully followed.

1. Carefully remove valve cap which covers adjusting screw.
Loosen locknut which locks adjusting screw so pressure setting will not change during operation of pump.
2. Install a pressure gauge in discharge line for actual adjustment operation.
3. Turn adjusting screw in to increase pressure and out to decrease pressure.
4. With discharge line closed at a point beyond pressure gauge, gauge will show maximum pressure the valve will allow while pump is in operation.

IMPORTANT

In ordering parts for pressure relief valve, always give model number and serial number of pump as it appears on nameplate and name of part wanted. When ordering springs, be sure to give pressure setting desired.

VIKING PUMP

IDEX
CORPORATION

WARRANTY

Viking warrants all products manufactured by it to be free from defects in workmanship or material for a period of one (1) year from date of startup, provided that in no event shall this warranty extend more than eighteen (18) months from the date of shipment from Viking. The warranty period for Universal Seal series pumps ONLY (Universal Seal models listed below) is three (3) years from date of startup, provided that in no event shall this warranty extend more than forty-two (42) months from the date of shipment from Viking.

UNDER NO CIRCUMSTANCES SHALL VIKING BE LIABLE UNDER THIS WARRANTY OR OTHERWISE FOR SPECIAL, INCIDENTAL, INDIRECT, CONSEQUENTIAL OR PUNITIVE DAMAGES OF ANY KIND, INCLUDING, BUT NOT LIMITED TO, LOSS OR UNREALIZED SALES, REVENUES, PROFITS, INCOME, COST SAVINGS OR BUSINESS, LOSS OR UNREALIZED CONTRACTS, LOSS OF GOODWILL, DAMAGE TO REPUTATION, LOSS OF PROPERTY, LOSS OF INFORMATION OR DATA, LOSS OF PRODUCTION, DOWNTIME, OR INCREASED COSTS, IN CONNECTION WITH ANY PRODUCT, EVEN IF VIKING HAS BEEN ADVISED OR PLACED ON NOTICE OF THE POSSIBILITY OF SUCH DAMAGES AND NOTWITHSTANDING THE FAILURE OF ANY ESSENTIAL PURPOSE OF ANY PRODUCT.

THIS WARRANTY IS AND SHALL BE VIKING'S SOLE AND EXCLUSIVE WARRANTY AND SHALL BE IN LIEU OF ALL OTHER WARRANTIES, EXPRESS OR IMPLIED, INCLUDING, BUT NOT LIMITED TO, ALL WARRANTIES OF MERCHANTABILITY, FITNESS FOR A PARTICULAR PURPOSE AND NON-INFRINGEMENT ALL OF WHICH OTHER WARRANTIES ARE EXPRESSLY EXCLUDED.

See complete warranty at www.vikingpump.com.