

# LIQUID-SPECIFIC PRODUCT LINE: CAST IRON ELECTRICALLY HEATED ASPHALT PUMPS

124E Series™, 324E Series™

Section	1465
Page	1465.1
Issue	B

## TABLE OF CONTENTS

Operating Range.....	1
Series Description.....	1
Related Products .....	1
Features & Benefits .....	2
Model Number Key .....	2
Standard Materials of Construction .....	2
Relief Valve Configurations.....	2
Porting & Sealing .....	2
Electric Heat Specifications .....	3
Controlling Electrically Heated Pumps .....	3
Control System.....	3
Specifications .....	4
Dimensions – H, HL, K, KK, L, LQ, LL, LS & Q Sizes.....	5
Dimensions – QS Size.....	6
Dimensions – N Size.....	6
Dimensions – H, HL, K, KK, L, LQ, LL, LS, Q, QS Sizes.....	7
Stuffing Box Seal Chamber Dimensions .....	8
NPSH Required .....	9

## SERIES DESCRIPTION

The electrically heated pump is specifically designed to heat the asphalt within the pump, prior to start-up. Heat cartridges located on the bracket or casing heat the area behind the rotor and stuffing box. The design also uses heat cartridges installed in the head to quickly melt asphalt throughout the casing.

## RELATED PRODUCTS

Cast Iron, 34 Series™: Catalog Section 1464

Cast Iron, 224A Series™: Catalog Section 1402

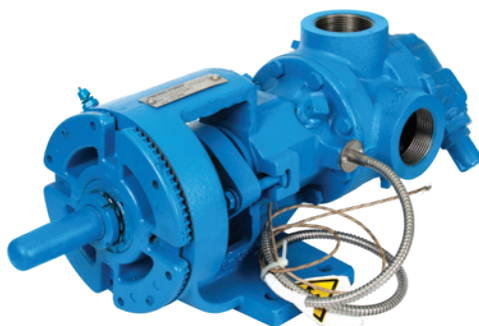

H124E



LS124E

## OPERATING RANGE

SERIES	NOMINAL FLOW		MAXIMUM PRESSURE		TEMPERATURE RANGE		VISCOSITY RANGE	
	GPM	m <sup>3</sup> h	PSI	Bar	°F	°C	SSU	cSt
124E Series™	15 - 500	3.4 - 114	200	14	-60 to +450	-50 to +230	28 to 2,000,000	.1 to 440,000
324E Series™	600 - 685	136 - 155	200	17	-60 to +450	-50 to +230	28 to 2,000,000	.1 to 440,000

<b>Section</b>	<b>1465</b>
<b>Page</b>	<b>1465.2</b>
<b>Issue</b>	<b>B</b>

# LIQUID-SPECIFIC PRODUCT LINE: CAST IRON ELECTRICALLY HEATED ASPHALT PUMPS

124E Series™, 324E Series™

## FEATURES & BENEFITS

- Reduced installation & maintenance expense
  - » Lower installation costs in remote locations when steam or hot oil is not available or requires long piping runs
  - » Provides expansion flexibility
  - » Eliminates the hot oil or steam system
  - » Simplified service due to the lack of hot oil or steam connections
- Reduce energy costs
  - » Eliminates heat loss through piping
  - » Reduces environmental costs by eliminating hot oil or steam piping

## MODEL NUMBER KEY

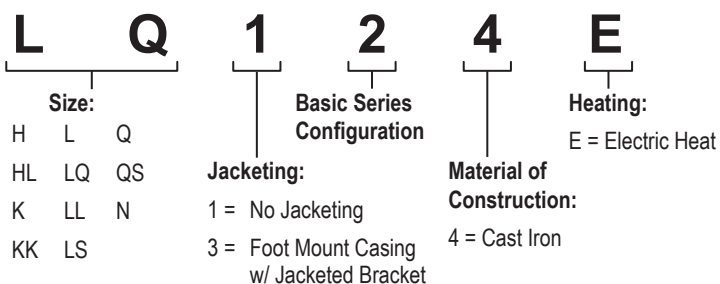

## STANDARD MATERIALS OF CONSTRUCTION

Pump Construction	Casing	Head	Bracket	Rotor	Idler	Rotor Shaft	Idler Pin	Packing	Idler Bushing	Bracket Bushing	Pressure Relief Valve
<b>Standard Construction</b>	Cast Iron ASTM A48, Class 35B	Cast Iron ASTM A48, Class 35B	Cast Iron ASTM A48, Class 35B	① Cast Iron ASTM A48, Class 35B	③ Cast Iron ASTM A48 Class 35B	⑤ Steel ASTM A108, Grade 1045	Hardened Steel ASTM A108, Grade 10L45	Standard	Bronze ASTM B584 (B505), Alloy C93700	Bronze ASTM B584 (B505), Alloy C93700	Cast Iron ASTM A48, Class 35B
<b>Steel Fitted</b>				④ Steel ASTM A108, Grade 1045	② Iron						

① KK, LS, QS sizes have ductile iron rotor, ASTM A536 Grade 60-40-18.

② Steel fitted Q and QS sizes have steel idler.

③ H and HL sizes have powdered metal idler, MPIF Std 35 FC-0208-50.

④ Material specification for HL steel rotor is AISI 8620, LS steel rotor is ASTM A148 80-50.

⑤ K, KK, L, LQ, LL and LS sizes are high strength steel ASTM A434 Type 4140 Grade BC or equivalent.

## RELIEF VALVE CONFIGURATIONS

Electrically heated pumps are provided with a non-jacketed relief valve as standard.

The "N" size pump is standard with a jacketed bracket, non-jacketed head and non-jacketed relief valve.

## PORTING & SEALING

A variety of opposite and 90° port configurations are available, including top suction with bottom or side discharge designs typically mounted at the bottom of a tank or reactor.

# LIQUID-SPECIFIC PRODUCT LINE: CAST IRON ELECTRICALLY HEATED ASPHALT PUMPS

124E Series™, 324E Series™

Section	1465
Page	1465.3
Issue	B

## ELECTRIC HEAT SPECIFICATIONS

Heat cartridges (pre-installed on pump)

All heaters are 240 VAC, 1 phase, 50/60 Hz

**Materials:** Incoloy® outer sheath, PFA moisture seal, Brass NPT fitting

**Leads:** Two fiberglass-insulated leads, rated to 840°F/450°C in flexible stainless steel conduit for abrasion resistance. The two leads extend 12" past end of stainless steel conduit. Normal practice is to wire all cartridges to local junction box at pump, with one cable to controller.

**Agency Approvals:** UL, CSA, VDE, CE

Pump Model	Head Cartridges	Watts/Cartridge (Head)	Bracket/Casing Cartridges	Watts/Cartridge (bracket/casing)	Total Watts
H124E	1	75	2	100	275
HL124E	1	75	2	100	275
K124E	3	130	2	150	690
KK124E	3	130	2	150	690
L124E	2	350	2	250	1200
LQ124E	2	350	2	250	1200
LL124E	2	375	2	250	1250
LS124E	2	375	2	250	1250
Q124E	3	500	2	350	2200
QS124E	3	500	2	350	2200
N324E	2	900	2 ①	350	2500

① Heat cartridges are located in the casing.

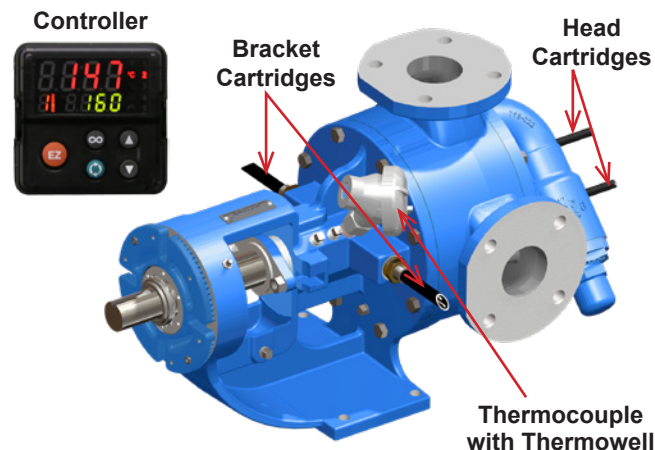

## CONTROLLING ELECTRICALLY HEATED PUMPS

Viking Pump offers a controller for its electrically heated pumps. It is a closed loop PID control providing fast, yet effective time to temperature with minimal overshoot to prevent overheating. The control system includes a thermocouple and thermowell adapter for mounting, and a controller which powers all the heat cartridges on one pump (N-size requires a 40-amp relay). The controller has a user-adjustable temperature set point, up to a preset maximum. When the set point is reached, a relay can be wired to alert the operator, or prevent a pump from being started until the asphalt is melted. It can be ordered with present maximum temperature of either 150°F, 250°F, 350°F or 450°F; or 65°C, 120°C, 175°C or 230°C. See Electric Heat Specifications for number of cartridge heaters and wattages by pump size.

## CONTROL SYSTEM

(accessory not included with pump)

### Thermocouple

Type J thermocouple with thermowell in weather-resistant housing with ½" MNPT fitting to mount in pump.

### Controller

**Enclosure:** 1/16 DIN, NEMA 4X / IP66 for panel mount

**Mains power:** 240 VAC, 1 phase

**Heater Output:** 15A NO-ARC, Form A

**Control Algorithm:** PID, with pre-set bandwidths

**Set point Achieved Relay Output:** Mechanical relay, 5A, Form A

**Agency Approvals:** UL, CSA, CE, RoHS, W.E.E.E., FM  
N-size pump requires a separate 40-amp relay.

**WARNING:** Use National Electric Code (NEC) or other country-specific standard wiring and safety practices when wiring and connecting this controller to a power source and to electrical sensors, heaters or peripheral devices. Failure to do so may result in damage to the equipment and property, and/or injury or loss of life.

Section	1465
Page	1465.4
Issue	B

## LIQUID-SPECIFIC PRODUCT LINE: CAST IRON ELECTRICALLY HEATED ASPHALT PUMPS

124E Series™, 324E Series™

### SPECIFICATIONS

Note: Sizes HL, K, KK, L/LQ, LS & N show two different max speed and pressure options. Use higher speed on clean asphalt only.

Model	① Ports	Nominal Pump Rating (750 SSU and below)				Maximum Hydrostatic Pressure		④ Maximum Discharge Pressure		⑤ Maximum Recommended Temperature for Standard Pump		Steel Fitted Recommended Above		Approximate Shipping Weight with Valve	
	In.	GPM	m³/hr	RPM	PSIG	BAR	PSIG	BAR	°F	°C	SSU	cSt	lbs.	kG	
H124E⑥	②1.5	15	3.4	1750	300	21	200	14	450	232	25,000	5,500	42	19	
HL124E⑥	②1.5	30	6.8	1750	300	21	200	14	450	232	7,500	1,650	45	21	
	②1.5	50	11	2900	300	21	125	9	450	232	7,500	1,650	45	21	
K124E	②2	75	17	780	300	21	200	14	450	232	25,000	5,500	110	50	
	②2	90	20	950	300	21	125	9	450	232	25,000	5,500	110	50	
KK124E	②2	100	23	780	300	21	200	14	450	232	25,000	5,500	115	52	
	②2	120	27	950	300	21	125	9	450	232	25,000	5,500	115	52	
L124E	②2	135	30	640	300	21	200	14	450	232	25,000	5,500	165	75	
	②2	210	48	950	300	21	125	9	450	232	25,000	5,500	165	75	
LQ124E	③2.5	135	30	640	300	21	200	14	450	232	25,000	5,500	185	84	
	③2.5	210	48	950	300	21	125	9	450	232	25,000	5,500	185	84	
LL124E	③3	140	32	520	300	21	200	14	450	232	2,500	550	195	88	
LS124E	③3	200	45	640	300	21	200	14	450	232	75,000	16,500	200	91	
	③3	230	52	720	300	21	125	9	450	232	75,000	16,500	200	91	
Q124E	③4	300	68	520	250	17	200	14	450	232	7,500	1,650	455	206	
QS124E	③6	500	114	520	250	17	200	14	450	232	75,000	16,500	555	252	
N324E	③6	600	136	350	250	17	200	14	450	232	75,000	16,500	810	376	
	③6	685	155	420	250	17	125	9	450	232	75,000	16,500	810	376	

① Port sizes are inch standard, not metric design or size.

② Ports are tapped for standard (NPT) pipe.

③ Ports are suitable for use with 125# ANSI cast iron flanges or flanged fittings.

④ For maximum recommended discharge pressures when handling other viscosities and/or other speeds, see performance curves, which can be electronically generated with the Viking Pump Curve Selector, located on [www.vikingpump.com](http://www.vikingpump.com). If suction pressure exceeds 50 PSIG, consult factory.

⑤ Higher temperatures can be handled with special construction, consult factory.

⑥ H and HL sizes available with tapped ports only due to interference between the bracket heat cartridge and flange.

# LIQUID-SPECIFIC PRODUCT LINE: CAST IRON ELECTRICALLY HEATED ASPHALT PUMPS

124E Series™, 324E Series™

Section	1465
Page	1465.5
Issue	B

## DIMENSIONS – H, HL, K, KK, L, LQ, LL, LS & Q SIZES

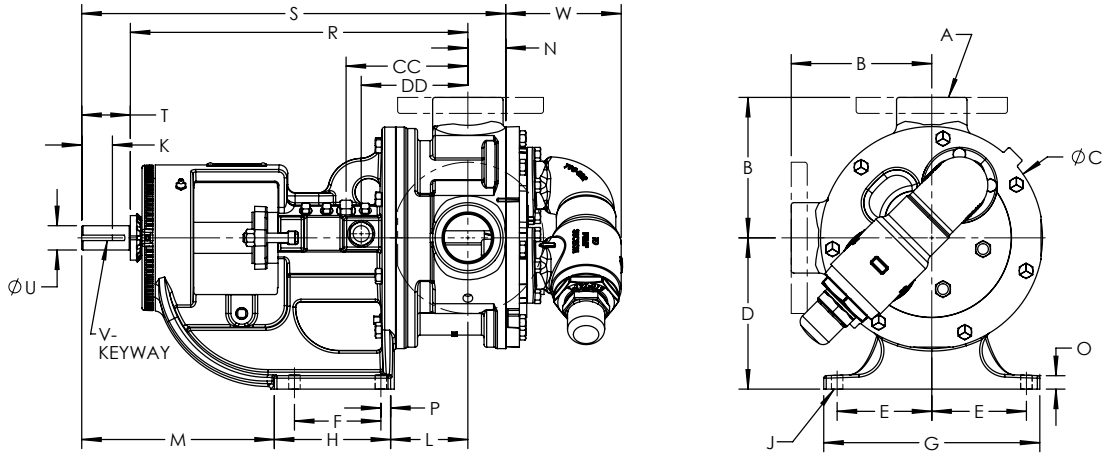

Model Number	A (in)		B	C	D	E	F	G	H	J	K	L
H124E	①	in	3.00	4.75	3.50	2.75	2.25	6.75	3.50	0.47	0.99	3.38
HL124E	1.5	mm	76.2	120.6	88.9	69.8	57.1	171.4	88.9	11.9	25.1	85.8
K124E	①	in	5.12	8.00	5.50	4.00	2.75	9.25	4.0	0.53	1.42	3.00
KK124E	2	mm	130.0	203.2	139.7	101.6	69.8	234.9	101.6	13.5	36.1	76.2
L124E	①	in	6.50	10.25	7.00	4.38	4.00	10.00	5.38	0.53	2.00	3.38
	2	mm	165.1	260.3	177.8	111.3	101.6	254.0	136.7	13.5	50.8	85.9
LQ124E	②	in	7.19	10.25	7.00	4.38	4.00	10.00	5.38	0.53	2.00	3.38
	2.5	mm	182.6	260.3	177.8	111.3	101.6	254.0	136.7	13.5	50.8	85.9
LL124E	②	in	7.19	10.25	7.00	4.38	4.00	10.00	5.38	0.53	2.00	3.38
	3	mm	182.6	260.3	177.8	111.3	101.6	254.0	136.7	13.5	50.8	85.9
LS124E	②	in	7.19	10.25	7.00	4.38	4.00	10.00	5.38	0.53	2.55	4.75
	3	mm	182.6	260.3	177.8	111.3	101.6	254.0	136.7	13.5	64.8	120.6
Q124E	②	in	8.25	14.00	8.75	4.12	4.00	10.00	6.00	0.69	3.58	6.62
	4	mm	209.5	355.6	222.2	104.6	101.6	254.0	152.4	17.5	90.9	168.1

Model Number		M	N	O	P	R	S	T	U	V	W	③ CC	④ DD
H124E	in	5.19	1.19	0.56	0.62	10.44	13.25	1.62	0.75	.19 x .09	2.85	2.84	2.40
HL124E	mm	131.8	30.2	14.2	15.7	265.2	336.5	41.1	19.0	4.83 x 2.29	72.4	72.14	60.96
K124E	in	9.38	1.75	0.62	0.62	14.12	18.12	2.25	1.12	.25 x .12	6.38	4.88	4.14
KK124E	mm	238.3	44.4	15.7	15.7	358.6	460.2	57.1	28.4	6.35 x 3.05	162.0	123.95	105.16
L124E	in	9.12	1.75	0.62	0.62	15.62	19.62	2.25	1.12	.25 x .12	5.43	5.62	4.92
	mm	231.6	44.4	15.7	15.7	396.7	498.3	57.1	28.7	6.35 x 3.05	137.9	142.75	124.97
LQ124E	in	9.12	1.75	0.62	0.62	15.62	19.62	2.25	1.12	.25 x .12	5.43	5.62	4.92
	mm	231.6	44.4	15.7	15.7	396.7	498.3	57.1	28.7	6.35 x 3.05	137.9	142.75	124.97
LL124E	in	9.12	2.25	0.62	0.62	15.62	20.12	2.25	1.12	.25 x .12	5.43	5.62	4.92
	mm	231.6	57.1	15.7	15.7	396.7	511.0	57.1	28.7	6.35 x 3.05	137.9	142.75	124.97
LS124E	in	9.12	2.44	0.62	0.62	15.75	21.69	3.50	1.44	.38 x .19	5.43	6.25	6.09
	mm	231.6	62.0	15.7	15.7	400.0	550.9	88.9	36.6	9.65 x 4.83	137.9	158.75	154.7
Q124E	in	11.12	3.00	0.75	1.00	19.25	26.75	4.50	1.94	.50 x .25	8.25	7.33	5.83
	mm	282.4	76.2	19.0	25.4	488.9	679.4	114.3	49.3	12.7 x 6.35	209.5	186.18	148.08

① Ports are tapped for standard (NPT) pipe. Other thread standards available.

③ Port centerline to thermocouple port

② Ports are suitable for use with Class 125 ANSI cast iron companion flanges.

④ Port centerline to bracket heat cartridge.

See drawing on Page 1465.7 for cartridge heater and thermocouple port location.

Dimensions given are for guidance only and should not be used for installation purposes. Certified dimensions will be supplied on request.

Section	1465
Page	1465.6
Issue	B

**LIQUID-SPECIFIC PRODUCT LINE:  
CAST IRON ELECTRICALLY HEATED ASPHALT PUMPS**  
124E Series™, 324E Series™

**DIMENSIONS – QS SIZE**

Dimensions shown in inches with millimeter equivalent shown in parentheses

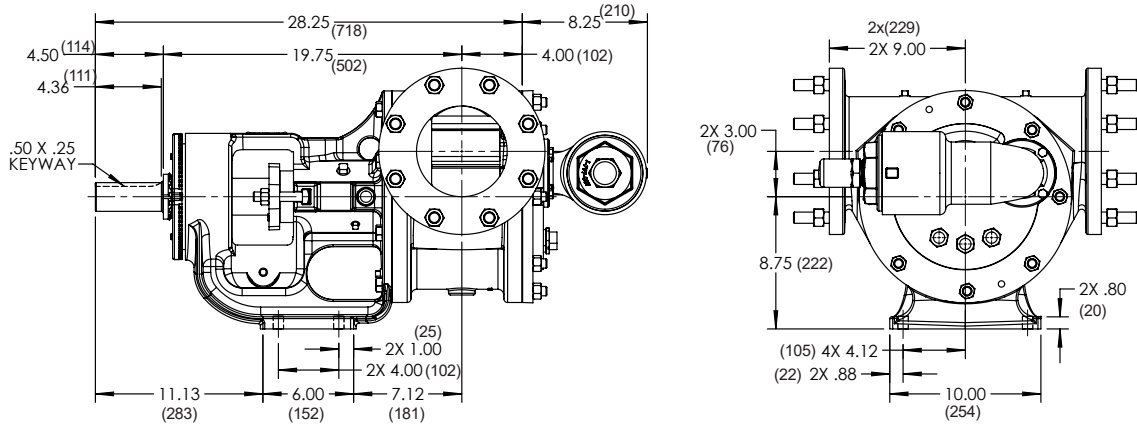

**DIMENSIONS – N SIZE**

Dimensions shown in inches with millimeter equivalent shown in parentheses

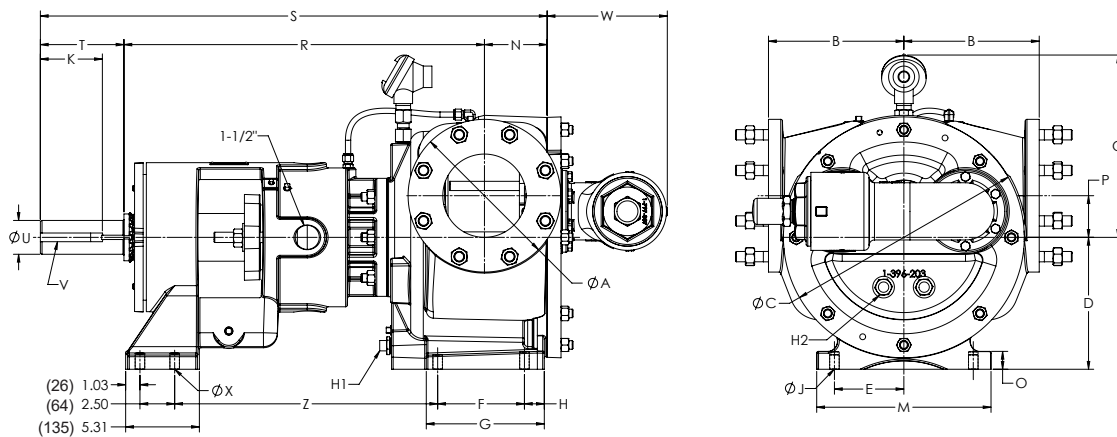

Model Number	A (in)	B	C	D	E	F	G	H	H1	H2	J	K	M	N	O	P	Q	R	S	T	U	V	W	X	Y	Z
N324E	① 6	in	9.75	17.25	9.50	5.00	6.25	8.69	1.62	0.75	0.69	4.50	12.00	4.50	1.00	3.00	13.11	26.00	36.50	6.00	2.44	.62 x.31	8.63	0.69	N/A	18.94
		mm	247.7	438.1	241.3	127.0	158.7	220.7	41.1	19	19	17.5	114.3	304.8	114.3	25.4	76.2	333	660.4	927.1	152.4	62.0	15.74 x7.87	219.2	17.5	N/A

① Ports are suitable for use with 125# ANSI cast iron.

Dimensions given are for guidance only and should not be used for installation purposes. Certified dimensions will be supplied on request.

# LIQUID-SPECIFIC PRODUCT LINE: CAST IRON ELECTRICALLY HEATED ASPHALT PUMPS

124E Series™, 324E Series™

Section	1465
Page	1465.7
Issue	B

## DIMENSIONS – H, HL, K, KK, L, LQ, LL, LS, Q, QS SIZES

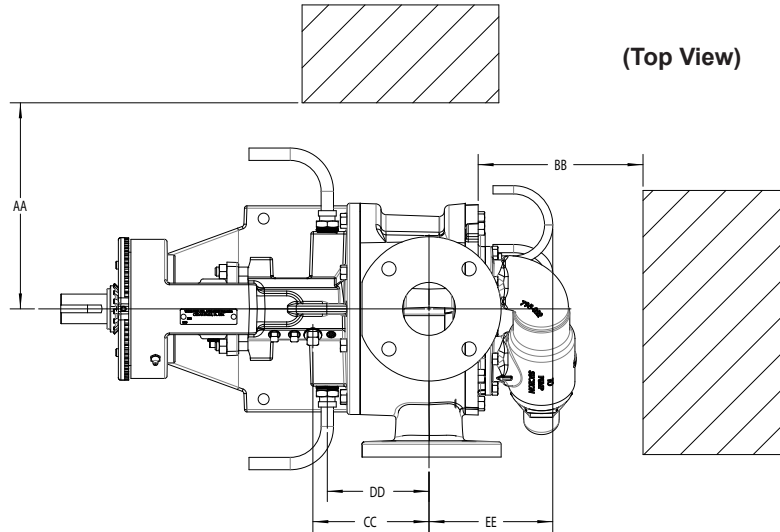

Model	Bracket Heater to Port Center Line (DD)		Temp Probe to Port Center Line (CC)		Head Heater to Port Center Line (EE)		Required to Remove Heater			
	Inch	mm	Inch	mm	Inch	mm	(AA)		(BB)	
							Inch	mm	Inch	mm
H124E HL124E	2.40	60.96	2.84	72.14	5.66	143.76	8.13	206.50	7.75	196.85
K124E KK124E	4.14	105.16	4.88	123.95	5.66	143.76	8.13	206.50	7.75	196.85
L124E	4.92	124.97	5.62	142.75	5.71	145.03	7.00	177.80	6.25	158.75
LQ124E					5.75	146.05				
LL124E					6.25	158.75				
LS124E	6.09	154.69	6.25	158.75	6.44	163.58	9.25	234.95	6.50	165.10
Q124E	5.83	148.08	7.33	186.18	8.25	209.55				
QS124E	6.33	160.78	7.83	198.88	9.25	234.95				

Section	1465
Page	1465.8
Issue	B

**LIQUID-SPECIFIC PRODUCT LINE:  
CAST IRON ELECTRICALLY HEATED ASPHALT PUMPS**  
124E Series™, 324E Series™

**STUFFING BOX SEAL CHAMBER DIMENSIONS**

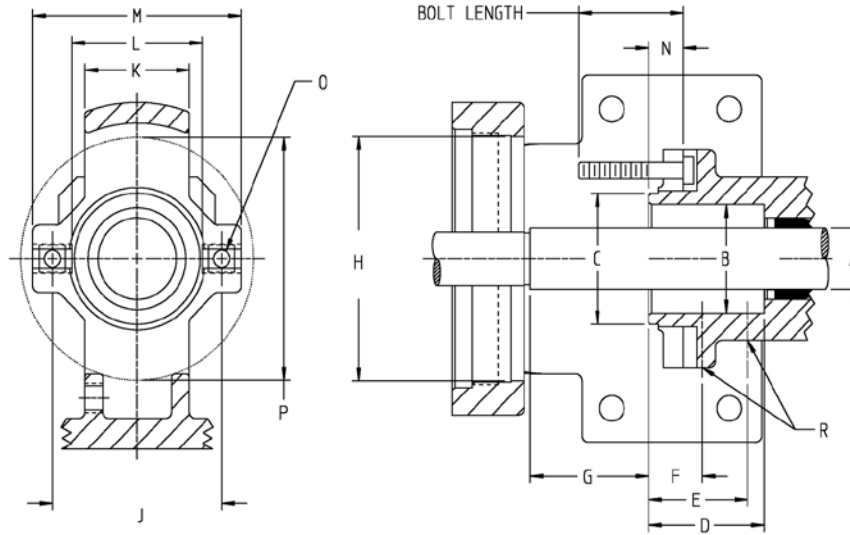

Pump Size		A	B	C	D	E	F	G	H	J	K	L	M	N	O	P	R
H & HL	In	1.12	2.00	2.41	2.22	1.90	1.03	2.27	4.50	3.00 to 3.50	2.00	2.50	4.00	0.66	5/16	4.47	1/8
	mm	28.6	50.8	61.2	56.4	48.3	26.2	57.7	114.3	76.2 to 88.9	50.8	63.5	101.6	16.8	7.9	113.5	3.2
K & KK	In	1.44	2.31①	3.00	3.13	2.25	1.25	3.00	5.25	3.50 to 4.50	2.50	3.00	5.00	0.38	7/16	5.25	1/4
	mm	36.5	58.7①	76.2	79.5	57.1	31.7	76.2	133.3	88.9 to 114.3	63.5	76.2	127.0	9.7	11.1	133.3	6.3
L, LQ, & LL (A)	In	1.44	2.31①	3.00	3.13	2.25	1.25	4.00	5.25	3.50 to 4.50	2.50	3.00	5.00	0.44	7/16	5.25	1/4
	mm	36.5	58.7①	76.2	79.5	57.1	31.7	101.6	133.3	88.9 to 114.3	63.5	76.2	127.0	11.2	11.1	133.3	6.3
LS	In	1.62	2.375	2.80	2.70	2.25	1.16	3.52	5.25	3.25 to 4.50	3.00	2.80	5.00	0.46	7/16	5.25	1/4
	mm	41.3	60.3	71.1	68.6	57.1	29.5	89.4	133.3	82.5 to 114.3	76.2	71.1	127.0	11.7	11.1	133.3	6.3
Q & QS	In	2.44	3.42	4.50	4.00	2.50	1.53	4.10	6.75	5.50 to 6.25	3.20	4.50	7.20	0.56	5/8	6.75	1/4
	mm	61.9	87.0	114.3	101.6	63.5	38.9	104.1	171.4	139.7 to 158.7	81.3	114.3	182.9	14.2	15.9	171.4	6.3
N	In	3.44	4.69	-	5.56	1.65	-	4.91	8.81	6.75	-	-	-	-	3/4②	9.00	1/4
	mm	87.3	119.3	-	141.2	41.9	-	124.7	223.8	171.4	-	-	-	-	19.0②	228.6	6.3

① Bracket is counter bored to a diameter of 2.687 inches (68.25 mm), 0.12 inches (3.05 mm) deep from stuffing box face.

② Studs are used in place of cap screws.



# LIQUID-SPECIFIC PRODUCT LINE: CAST IRON ELECTRICALLY HEATED ASPHALT PUMPS

124E Series™, 324E Series™

Section	1465
Page	1465.9
Issue	B

## NPSH REQUIRED

Printed performance curves are not available.

Performance curves can be electronically generated with the Viking Pump Curve Generator on [vikingpump.com](http://vikingpump.com).

NPSH<sub>R</sub> data is not available on the curve generator.

**NPSH (Net Positive Suction Head):** The NPSH<sub>R</sub> (Net Positive Suction Head Required by the pump) is given in the table below and applies for viscosities through 750 SSU. NPSH<sub>A</sub> (Net Positive Suction Head – Available in the system) must be greater than the NPSH<sub>R</sub>. For a complete explanation of NPSH, see Application Data Sheet AD-19.

**FOR VISCOSITIES UP TO 750 SSU** – See NPSH<sub>R</sub> table below.

**NPSH<sub>R</sub> for high viscosities can be estimated using the following method:**

1. Calculate line loss for a 1 foot long pipe of a diameter matching the pump inlet port size. Use your flow rate and max viscosity.
2. Convert this value into Feet of Liquid (S.G. 1.0)
3. Add this value to the NPSH<sub>R</sub> value in the chart below.

PUMP SIZE	PUMP SPEED [RPM]														
	100	125	155	190	230	280	350	420	520	640	780	950	1150	1450	1750
H, HL					1.7	1.8	1.9	2.1	2.4	2.8	3.4	4.5	6.2	9.5	13.5
K, KK		1.7	1.8	1.9	2.1	2.3	2.8	3.3	4.4	6.3	9.1	—	—	—	—
L, LQ, LL, LS	1.7	1.8	2.0	2.2	2.5	3.0	3.8	5.0	7.3	10.8	—	—	—	—	—
Q, QS	1.9	2.1	2.3	2.7	3.3	4.2	6.1	8.4	12.7	—	—	—	—	—	—
N	2.1	2.5	3.5	4.5	6.3	9.5	15.0	—	—	—	—	—	—	—	—

**Note:** NPSH<sub>R</sub> – FEET OF LIQUID (Specific Gravity 1.0), Viscosities up to 750 SSU