

VIKING® HEAVY DUTY PUMPS

SERIES 337 AND 4337
STAINLESS STEEL

Section	163
Page	163.1
Issue	B

FEATURES

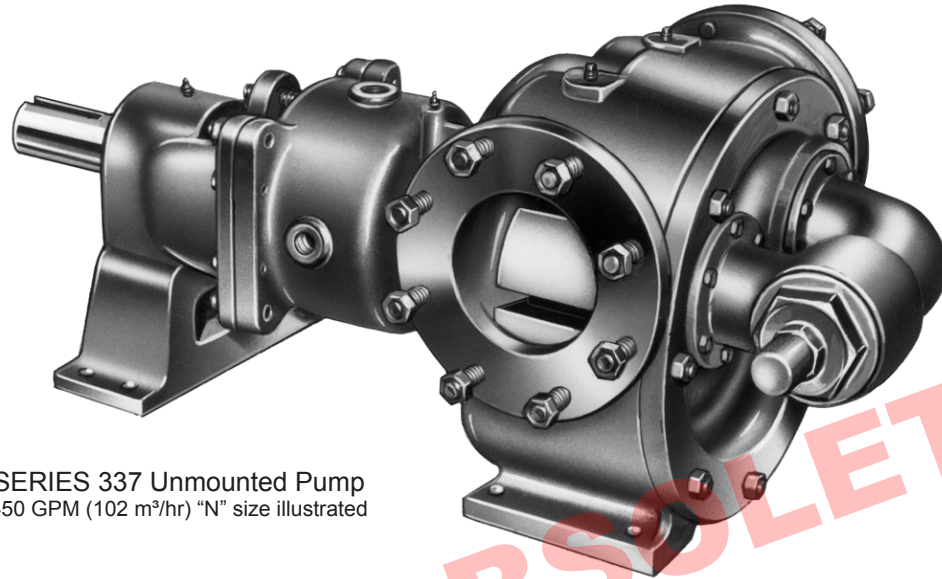

SERIES 337 Unmounted Pump
450 GPM (102 m³/hr) "N" size illustrated

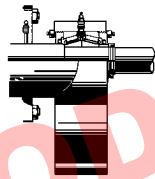

INTEGRAL THRUST BEARING
(Standard Equipment)

Both sizes of the large Series 337 and 4337 Heavy-Duty pumps are equipped with pedestal supported rotor thrust bearings. This results in a fully rigid and positive alignment and eliminates the need of a second shaft support. Rotor adjustment is provided by means of two adjusting nuts.

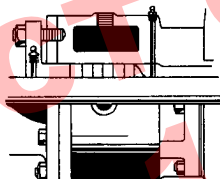

JACKETED ROTOR BEARING SLEEVE
(Standard Equipment)

The "N" and "R" size Series 337 and 4337 pumps come standard equipped with a single piece, jacketed, rotor bearing sleeve. Generous jacketed area is suitable for steam or other heating or cooling media. Jacket equipped with handy steam or cooling connections.

① Pressure Range	50 PSI (3 BAR) for 38 to 100 SSU (21 cSt)
	75 PSI (5 BAR) for 100 to 2500 SSU (540 cSt)
	100 PSI (7 BAR) for 2500 SSU (540 cSt) and above
① Temperature Range	-20°F. to +450°F. (-29°C. to +232°C.)
① Viscosity Range	28 to 2,000,000 SSU (1.0 to 440,000 cSt)

② G.P.M. 450 - 700
(m³/hr 102 - 159)
(Nominal Rating)

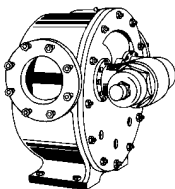

COMBINATION JACKETED AND RELIEF VALVE HEAD
(Standard Equipment)

The 700 GPM size pump in the Heavy-Duty Series 337 and 4337 features a combination jacketed and relief valve type head as standard equipment. Valve is standard and can be turned end for end when reversing pump rotation. Valve points toward suction port.

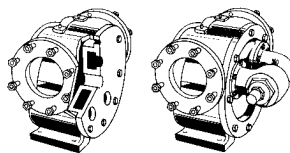

JACKETED OR RELIEF VALVE HEAD
(Standard Equipment)

The "N" size 450 GPM Heavy-Duty Series 337 and 4337 pump can be furnished with a jacketed or valve type head. (Valve type standard.) Not available in combination. Generous steam chambers in jacketing permit heating of pump. See valve information at left.

Viking's large capacity Series 337 (packed) and Series 4337 (mechanical seal) Stainless Steel pumps are applied throughout the chemical, petrochemical, food, cosmetic and coatings industries. Grade 316 Stainless Steel is used in major wetted parts which come in contact with the liquid to avoid contamination or discoloration of the product. The 316 Stainless Steel is also less sensitive to product impurities and can be used on a variety of corrosive liquid applications.

- ① Values shown represent maximums. Some special construction or consideration may be required before a cataloged pump can be applied to an application involving the maximum pressure, temperature and/or viscosity.
- ② Nominal capacities based on handling thin liquids at low pressures.

Metric conversions are based on US measurements and rounded to the nearest whole number.

Section	163
Page	163.2
Issue	C

VIKING® HEAVY DUTY PUMPS

SERIES 337 AND 4337

STAINLESS STEEL

UNMOUNTED PUMPS

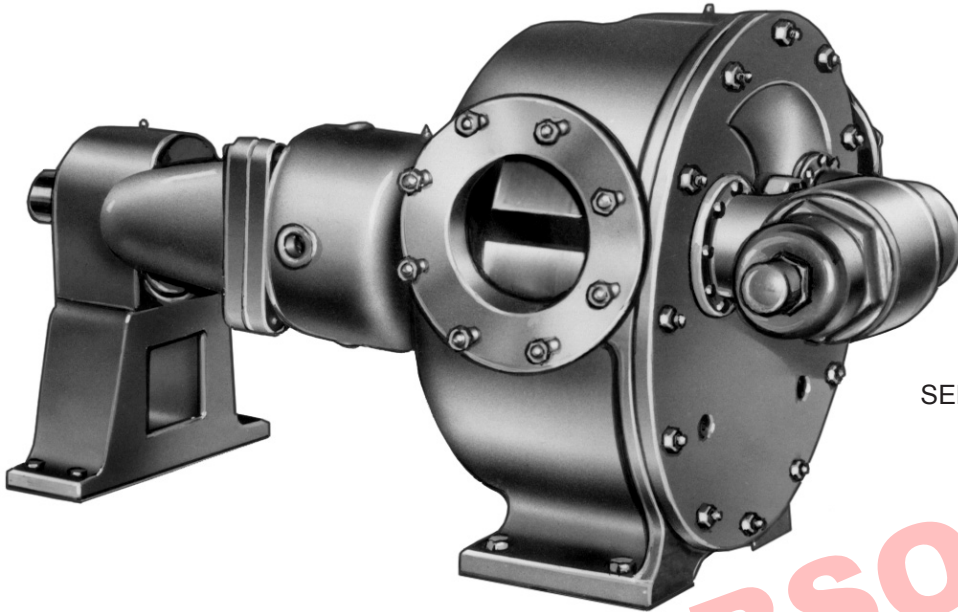

SERIES 337 Unmounted Pump
"R" size illustrated

The Series 337 (packed) and Series 4337 (mechanical seal) pumps are furnished with horizontal ports although other port locations can be supplied on special request. Both the 450 and 700 GPM sizes are furnished with thrust bearing pedestal support and internal-type safety relief valve as standard. Generous jacketed area is provided in the rotor bearing sleeve for heating or cooling. In the Series 4337 the standard seal is a

PTFE type with carbon rotating and corrosion resistant stationary faces. High quality type 316 Stainless Steel is provided on wetted parts which come in contact with the pumped product.

⑤ Dimensions for Unmounted Pumps—See Page 163.4.

⑥ Performance Data for Unmounted Pumps—See Pages 163.7 thru 163.12.

CONSTRUCTION — SERIES 337 AND 4337 "N" AND "R" SIZES

Pump Construction	Casing	Rotor Bearing Sleeve	Head	Rotor	Idler	Rotor Shaft and Idler Pin	Bushings	Shaft Sealing		Internal Relief Valve
								Packed	Mechanical Seal	
316 Stainless	Stainless Steel	Stainless Steel	Stainless Steel	Stainless Steel	Stainless Steel	Coated Stainless Steel	Carbon Graphite	Standard	Stainless Steel PTFE with Carbon Graphite and Corrosion Resistant Material	Stainless Steel

SPECIFICATIONS — UNMOUNTED PUMPS

Model Number	① Port Size	② Nominal Pump Rating			Motor HP Required At Rated Speed Pumping 100 SSU Liquid			Maximum Hydrostatic Pressure	④ Maximum Recommended Discharge Pressure PSIG			⑤ Maximum Recommended Temperature For Cataloged Pump °F. (°C.)		⑥ Maximum Temperature / Pressure of Fluids In Jackets				Approx. Shipping Weight With Valve	
		Inches	GPM (m³/hr)	RPM	25 PSI (2 BAR)	50 PSI (3 BAR)	100 PSI (7 BAR)		PSIG (BAR)	③ 38 to 100 SSU	100 to 2500 SSU	2500 and up SSU	Packed	Mech. Seal	Steam (Sat.)		Heat Transfer Oil		
Packed	⑦ Mech. Seal													Temp. °F. (°C.)	Pressure PSIG (BAR)	Temp. °F. (°C.)	Pressure PSIG (BAR)	Pounds (KG)	
N337	N4337	6	450	102	280	20	30	50	400 (28)	50	75	100	225 (107)	225 (107)	365 (185)	150 (10)	450 (232)	150 (10)	810 (368)
R337	R4337	8	700	159	190	40	50	100	400 (28)	50	75	100	225 (107)	225 (107)	365 (185)	150 (10)	450 (232)	150 (10)	1435 (651)

① Flanged ports are suitable for use with 150# ANSI Stainless Steel companion flanges or flanged fittings.

② Nominal capacities based on handling thin liquids at low pressures.

③ For handling liquids of less than 38 SSU (4 cSt) viscosity, special construction features may be required. Provide details for recommendations.

④ If suction pressure exceeds 50 PSIG (3 BAR), check factory with details.

⑤ With special construction temperatures to 450° F. can be handled. Under certain

conditions higher temperatures may be considered. Check factory with details.

⑥ Jacketed rotor bearing sleeve (stuffing box) is standard on both pumps. Jacketed head is available on the "N" size pump. On the "R" size a combination jacketed AND relief valve head is standard, the jacketed relief valve is not available.

⑦ For mechanical seal pumps (Series 4337) on applications with viscosities above 25,000 SSU (5,500 cSt) provide details to factory for recommendations.

Metric conversions are based on US measurements and rounded to the nearest whole number.

VIKING® HEAVY DUTY PUMPS

SERIES 337 AND 4337
STAINLESS STEEL

Section	163
Page	163.3
Issue	B

GEAR REDUCER UNITS (“P” DRIVE)

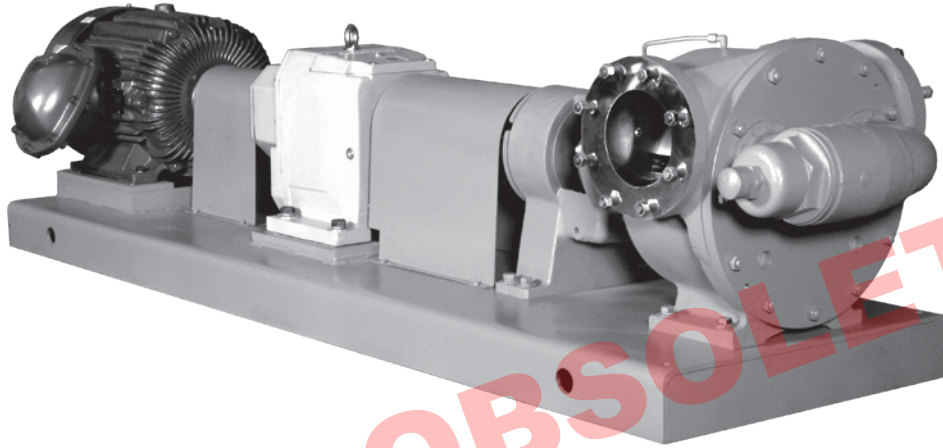

Example of Purchased Reducer Drive

The Viking Heavy-Duty Series 337 (packed) and 4337 (mechanical seal) pumps in two sizes—“N” and “R”—are available in the “P” drive arrangement.

These “P” Drive Heavy-Duty Units are mounted on structural steel bases as illustrated above. All mount the pumps with separate heavy-duty reducers and are

connected through flexible couplings between pumps, reducers and motors. Coupling guards, as illustrated are standard construction.

Dimensions for “P” Drive Units—Consult factory.

Performance Data for “P” Drive Units—See Pages 163.7 thru 163.12.

SPECIFICATIONS — “P” DRIVE

Model Number	① Port Size	② Nominal Pump Rating			Motor HP Required At Rated Speed Pumping 100 SSU Liquid			Maximum Hydrostatic Pressure	④ Maximum Recommended Discharge Pressure PSIG			⑤ Maximum Recommended Temperature For Cataloged Pump °F. (°C.)		⑥ Maximum Temperature / Pressure of Fluids In Jackets				Approx. Shipping Weight With Valve
														Steam (Sat.)		Heat Transfer Oil		
Packed	⑦ Mech. Seal	Inches	GPM (m³/hr)	RPM	25 PSI (2 BAR)	50 PSI (3 BAR)	100 PSI (7 BAR)	PSIG (BAR)	③ 38 to 100 SSU	100 to 2500 SSU	2500 and up SSU	Packed	Mech. Seal	Temp. °F. (°C.)	Pressure PSIG (BAR)	Temp. °F. (°C.)	Pressure PSIG (BAR)	Pounds (KG)
N337P	N4337P	6	450 102	280	20	30	50	400 (28)	50	75	100	225 (107)	225 (107)	365 (185)	150 (10)	450 (232)	150 (10)	1450 (658)
R337P	R4337P	8	700 159	190	40	50	100	400 (28)	50	75	100	225 (107)	225 (107)	365 (185)	150 (10)	450 (232)	150 (10)	2190 (994)

- ① Flanged ports are suitable for use with 150# ANSI Stainless Steel companion flanges or flanged fittings.
- ② Nominal capacities based on handling thin liquids at low pressures.
- ③ For handling liquids of less than 38 SSU (4 cSt) viscosity, special construction features may be required. Provide details for recommendations.
- ④ If suction pressure exceeds 50 PSIG (3 BAR), check factory with details.
- ⑤ With special construction temperatures to 450° F. can be handled. Under certain

- conditions higher temperatures may be considered. Check factory with details.
- ⑥ Jacketed rotor bearing sleeve (stuffing box) is standard on both pumps. Jacketed head is available on the “N” size pump. On the “R” size a combination jacketed AND relief valve head is standard, the jacketed relief valve is not available.
- ⑦ For mechanical seal pumps (Series 4337) on applications with viscosities above 25,000 SSU provide details to factory for recommendations.

Metric conversions are based on US measurements and rounded to the nearest whole number.

Section	163
Page	163.4
Issue	D

VIKING® HEAVY DUTY PUMPS

SERIES 337 AND 4337

STAINLESS STEEL

DIMENSIONS

These dimensions are average and not for construction purposes. Certified prints on request.

For specifications, see page 163.2.

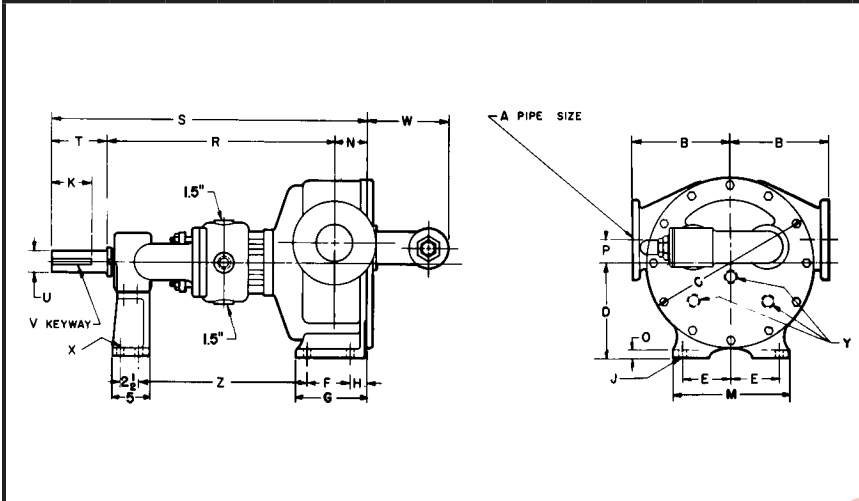

DIMENSIONS — SERIES 337 AND 4337 UNMOUNTED PUMPS

① Flanged ports are suitable for use with 150# ANSI Stainless Steel companion flanges or flanged fittings.

MODEL NO.		A	B	C	D	E	F	G	H	J	K	M	N	O	P	R	S	T	U	V	W	X	Y	Z
N337 AND N4337	in	① 6.00	9.75	17.25	9.50	5.00	6.25	8.69	1.62	.69	4.50	12.00	4.50	1.00	3.00	26.00	36.50	6.00	2.44	.62 x .31	8.50	.69	0	18.94
	mm	① 152	248	438	241	127	159	221	41	18	114	305	114	25	76	660	927	152	62	16 x 8	216	18	0	481
R337 AND R4337	in	① 8.00	14.25	24.50	13.25	6.75	7.00	10.56	2.31	.78	5.00	16.00	5.62	1.00	4.50	26.62	41.00	8.75	2.44	.62 x .31	11.88	.69	1.5	19.25
	mm	① 203	362	622	337	171	178	268	59	20	127	406	143	25	114	676	1041	222	62	16 x 8	302	18	32	495