

VIKING® HEAVY DUTY PUMPS

SERIES 335 AND 4335

Section	143
Page	143.1
Issue	B

FEATURES

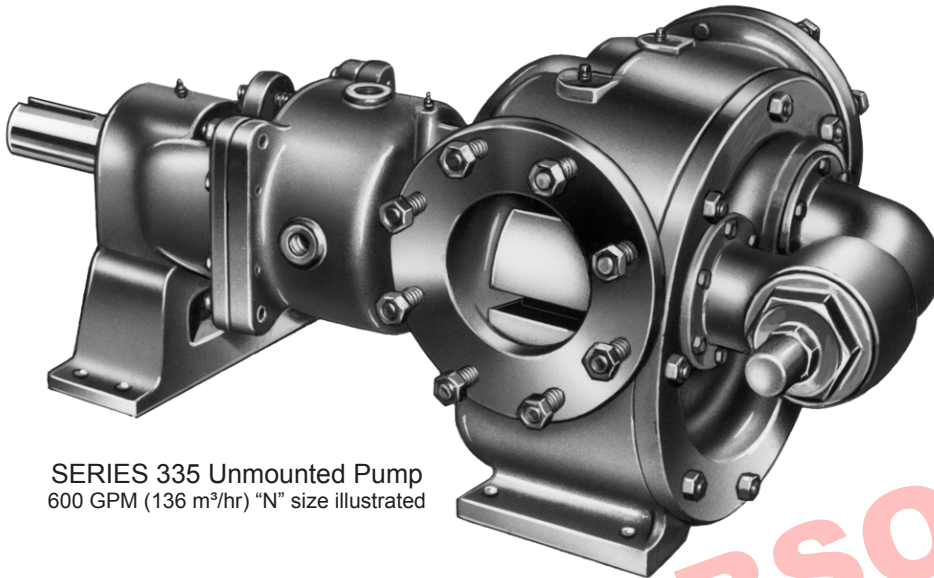

SERIES 335 Unmounted Pump
600 GPM (136 m³/hr) "N" size illustrated

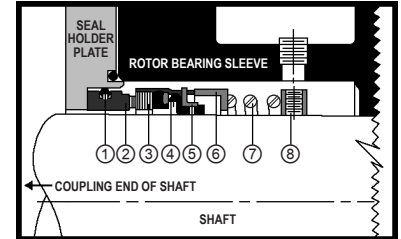

MECHANICAL SEAL — SERIES 4335

- ① Buna-N O-Ring
- ② Ni-Resist Stationary Seat
- ③ Carbon Rotating Face
- ④ Buna-N Bellows
- ⑤ Steel Metal Parts
- ⑥ Steel Spring Adapter
- ⑦ Steel Spring
- ⑧ Steel Set Collar

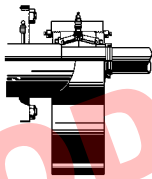

INTEGRAL THRUST BEARING (Standard Equipment)

Both sizes of the large Series 335 and 4335 Heavy-Duty pumps are equipped with pedestal supported rotor thrust bearings. This results in a fully rigid and positive alignment and eliminates the need of a second shaft support. Rotor adjustment is provided by means of two adjusting nuts.

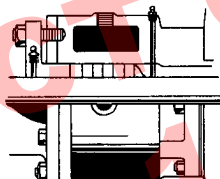

JACKETED ROTOR BEARING SLEEVE (Standard Equipment)

The "N" and "R" size Series 335 and 4335 pumps come standard equipped with a single piece, jacketed, rotor bearing sleeve. Generous jacketed area is suitable for steam or other heating or cooling media. Jacket equipped with handy steam or cooling connections.

① Pressure Range	125 PSI (9 BAR) for 100 SSU (21 cSt) and above 75 PSI (5 BAR) for below 100 SSU (21 cSt)
① Temperature Range	-60°F. to +450°F. (-51°C. to +232°C.)
① Viscosity Range	28 to 2,000,000 SSU (1.0 to 440,000 cSt)

② G.P.M. 600 - 1100 (m³/hr 136 - 250) (Nominal Rating)

Viking's Series 335 and 4335 pumps answer the need for large capacity pumps of heavy-duty construction. They are suitable for pressures up to 125 PSI on lubricating liquids, 75 PSI on non-lubricating liquids. They are also suitable for pumping thin or viscous liquids. See range above.

Viking pumps possess excellent vacuum-developing characteristics. Pumps are built to operate for long periods of time without overheating the rotor bearing sleeve bushing. This bushing can be cooled by the liquid being pumped, or this jacketed rotor bearing sleeve is also suitable for steam or other heating media.

These heavy-duty pumps can also be installed on lighter duty service resulting in greatly extended pump life and efficiency.

- ① Values shown represent maximums. Some special construction or consideration may be required before a cataloged pump can be applied to an application involving maximum pressure, temperature and/or viscosity.
- ② Nominal capacities based on handling thin liquids at low pressures.

Metric conversions are based on US measurements and rounded to the nearest whole number.

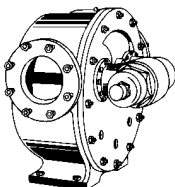

COMBINATION JACKETED AND RELIEF VALVE HEAD (Standard Equipment)

The 1100 GPM size pump in the Heavy-Duty Series 335 and 4335 features a combination jacketed and relief valve type head as standard equipment. Valve is standard and can be turned end for end when reversing pump rotation. Valve points toward suction port.

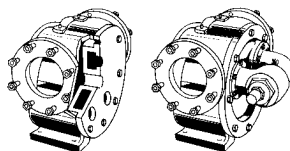

JACKETED OR RELIEF VALVE HEAD (Standard Equipment)

The "N" size 600 GPM Heavy-Duty Series 335 and 4335 pump can be furnished with a jacketed or valve type head. (Valve type standard.) Not available in combination. Generous steam chambers in jacketing permit heating of pump. See valve information at left.

Section	143
Page	143.2
Issue	B

VIKING® HEAVY DUTY PUMPS

SERIES 335 AND 4335

UNMOUNTED PUMPS

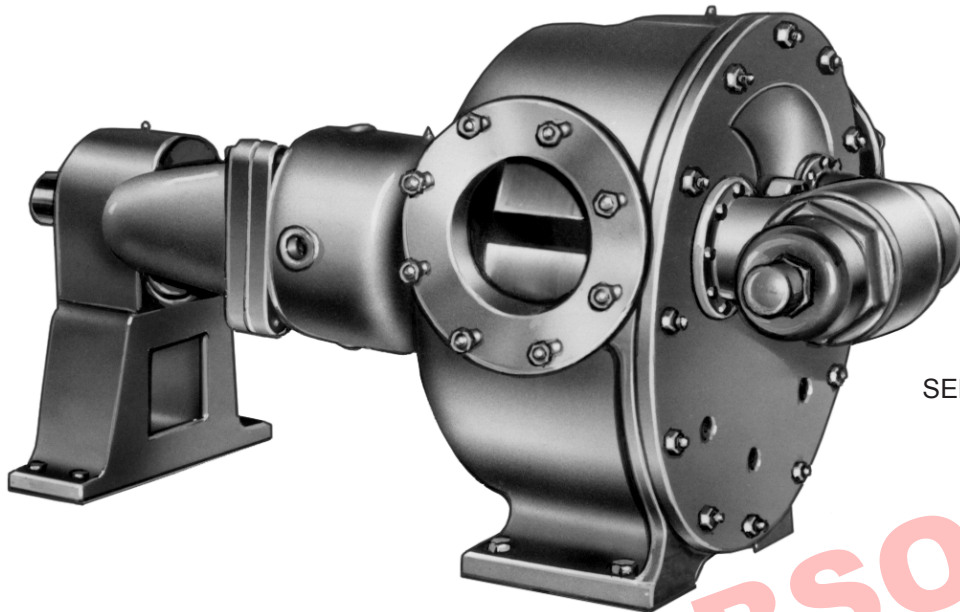

SERIES 335 Unmounted Pump
"R" size illustrated

The Series 335 and 4335 Heavy-Duty Viking pumps are built for bulk handling of both thin and viscous liquids. These large size pumps are popular for barge, tanker and terminal loading and unloading since pumps are fast, self-priming and capable of completely stripping tanks without additional equipment.

The Series 335 and 4335 pumps as illustrated are furnished with horizontal ports. However other port arrangements can be furnished on special order. Both

sizes are furnished with the thrust bearing pedestal support and with valve on head as standard. Both packed and mechanical seal types available. Standard seal equipped with Buna-N elastomer, carbon rotating and Ni-Resist stationary faces.

For Optional Seals—Contact Factory.

Dimensions for Unmounted Pumps—See Page 143.4.

Performance Data for Unmounted Pumps—See Pages 143.7 thru 143.12.

CONSTRUCTION — 335 AND 4335 SERIES "N" AND "R" SIZES

Pump Construction	Casing	Rotor Bearing Sleeve	Head	Rotor	Idler	Rotor Shaft and Idler Pin	Bushings		Internal Relief Valve
							Packed	Mechanical Seal	
Standard Construction	Iron	Iron	Iron	⊗ Iron	Iron	Steel	Bronze	Carbon Graphite	Iron
Steel Fitted	Iron	Iron	Iron	Steel	Iron	Steel	Bronze	Carbon Graphite	Iron

SPECIFICATIONS — UNMOUNTED PUMPS

Model Number	Ⓛ Port Size	Ⓢ Nominal Pump Rating	Motor HP Required At Rated Speed Pumping 100 SSU Liquid			Maximum Hydrostatic Pressure PSIG (BAR)	ⓈⓈⓈ Maximum Recommended Discharge Pressure Handling 100 SSU Liquid at Nominal Rated Speeds PSIG	Ⓢ Maximum Recommended Temperature For Cataloged Pump °F. (°C.)		Steel Fitted Construction Recommended Above This Viscosity SSU (cSt)	Ⓢ Maximum Temperature / Pressure of Fluids In Jackets				Approx. Shipping Weight With Valve Pounds (KG)		
			25 PSI (2 BAR)	50 PSI (3 BAR)	100 PSI (7 BAR)			Ⓢ Packed	Ⓢ Mech. Seal		Temp. °F. (°C.)	Pressure PSIG (BAR)	Temp. °F. (°C.)	Pressure PSIG (BAR)			
N335	N4335	6	600 (136)	350	20	30	50	400 (28)	125	300 (149)	225 (107)	75,000 (16,500)	365 (185)	150 (10)	450 (232)	150 (10)	810 (368)
R335	R4335	8	1100 (250)	280	40	50	100	400 (28)	125	300 (149)	225 (107)	25,000 (5,500)	365 (185)	150 (10)	450 (232)	150 (10)	1435 (651)

Ⓛ Flanged ports are suitable for use with 125# ANSI cast iron or 150# ANSI steel companion flanges or flanged fittings.

Ⓢ External force feed lubrication to bushings is recommended when pump might run dry or when a steam or thin liquid flush cycle is used.

Ⓢ For maximum recommended discharge pressures when handling other viscosities and/or at other speeds, see performance curves. Performance curves also show preferred constructions.

Ⓢ Buna-N elastomer used in mechanical seal of Series 4335 pumps. On applications above 15,000 SSU (3,300 cSt), provide details for recommendation.

Ⓢ Nominal capacities based on handling thin liquids at low pressure.

Ⓢ If suction pressure exceeds 50 PSIG (3 BAR), check factory with details.

Ⓢ With special construction temperatures to 450° F. can be handled. Under certain conditions higher temperature may be considered. Check factory with details.

Ⓢ Jacketed rotor bearing sleeve (stuffing box) is standard on both pumps. Jacketed head OR jacketed relief valve is available (not in combination) on the "N" size pump. On the "R" size a combination jacketed AND relief valve head is standard, the jacketed relief valve is not available.

Ⓢ "N" size has ductile iron rotor.

Metric conversions are based on US measurements and rounded to the nearest whole number.

VIKING® HEAVY DUTY PUMPS

SERIES 335 AND 4335

Section	143
Page	143.3
Issue	B

GEAR REDUCER UNITS (“P” DRIVE)

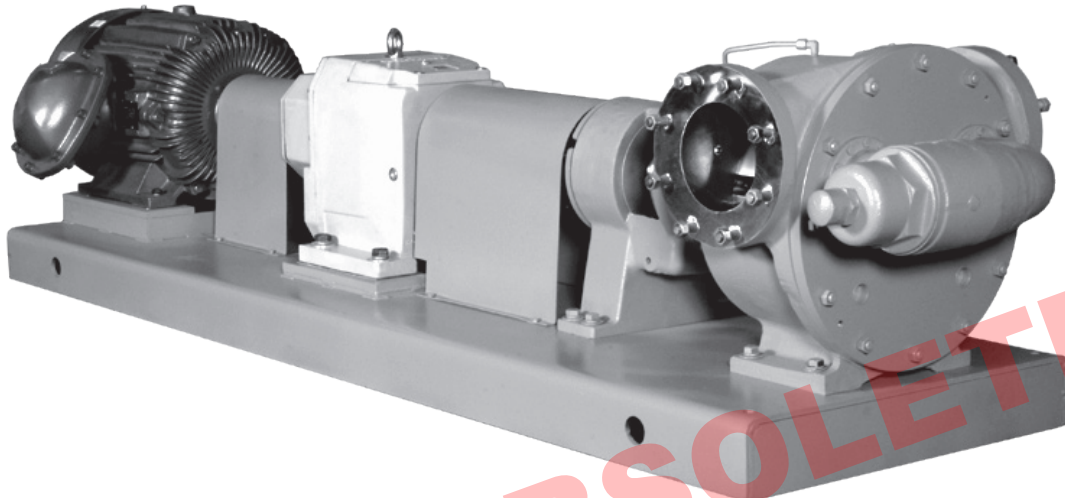

Example of Purchased Reducer Drive

The Viking Heavy-Duty Series 335 (packed) and 4335 (mechanical seal) pumps in two sizes—“N” and “R”—are available in the “P” drive arrangement.

These “P” Drive Heavy-Duty Units are mounted on structural steel bases as illustrated above. All mount the pumps with separate heavy-duty reducers and are

connected through flexible couplings between pumps, reducers and motors. Coupling guards, as illustrated are standard construction.

Dimensions for “P” Drive Units—Consult factory.

Performance Data for “P” Drive Units—See Pages 143.7 thru 143.12.

SPECIFICATIONS — “P” DRIVE

Model Number	① Port Size	⑤ Nominal Pump Rating			Motor HP Required At Rated Speed Pumping 100 SSU Liquid			Maximum Hydrostatic Pressure	②③⑥ Maximum Recommended Discharge Pressure Handling 100 SSU Liquid at Nominal Rated Speeds	⑦ Maximum Recommended Temperature For Cataloged Pump °F. (°C.)		Steel Fitted Construction Recommended Above This Viscosity	⑧ Maximum Temperature / Pressure of Fluids in Jackets				Approx. Shipping Weight With Valve (Less Reducer and Power)
													Steam (Sat.)		Heat Transfer Oil		
Packed	④ Mech. Seal	Inches	GPM (m ³ /hr)	RPM	25 PSI (2 BAR)	50 PSI (3 BAR)	100 PSI (7 BAR)	PSIG (BAR)	PSIG	Packed	Mech. Seal	SSU (cSt)	Temp. °F. (°C.)	Pressure PSIG (BAR)	Temp. °F. (°C.)	Pressure PSIG (BAR)	Pounds (KG)
N335P	N4335P	6	600 (136)	350	20	30	50	400 (28)	125	300 (149)	225 (107)	75,000 (16,500)	365 (185)	150 (10)	450 (232)	150 (10)	1450 (658)
R335P	R4335P	8	1100 (250)	280	40	50	100	400 (28)	125	300 (149)	225 (107)	25,000 (5,500)	365 (185)	150 (10)	450 (232)	150 (10)	2190 (994)

- ① Flanged ports are suitable for use with 125# ANSI cast iron or 150# ANSI steel companion flanges or flanged fittings.
- ② External force feed lubrication to bushings is recommended when pump might run dry or when a steam or thin liquid flush cycle is used.
- ③ For maximum recommended discharge pressures when handling other viscosities and/or at other speeds, see performance curves. Performance curves also show preferred constructions.
- ④ Buna-N elastomer used in mechanical seal of Series 4335 pumps. On applications above 15,000 SSU (3,300 cSt), provide details for recommendation.

- ⑤ Nominal capacities based on handling thin liquids at low pressure.
- ⑥ If suction pressure exceeds 50 PSIG (3 BAR), check factory with details.
- ⑦ With special construction, temperatures to 450° F. can be handled. Under certain conditions higher temperature may be considered. Check factory with details.
- ⑧ Jacketed rotor bearing sleeve (stuffing box) is standard on both pumps. Jacketed head **OR** jacketed relief valve is available (not in combination) on the “N” size pump. On the “R” size a combination jacketed **AND** relief valve head is standard, the jacketed relief valve is not available.

Metric conversions are based on US measurements and rounded to the nearest whole number.

Section	143
Page	143.4
Issue	D

VIKING® HEAVY DUTY PUMPS

SERIES 335 AND 4335

DIMENSIONS

These dimensions are average and not for construction purposes. Certified prints on request.

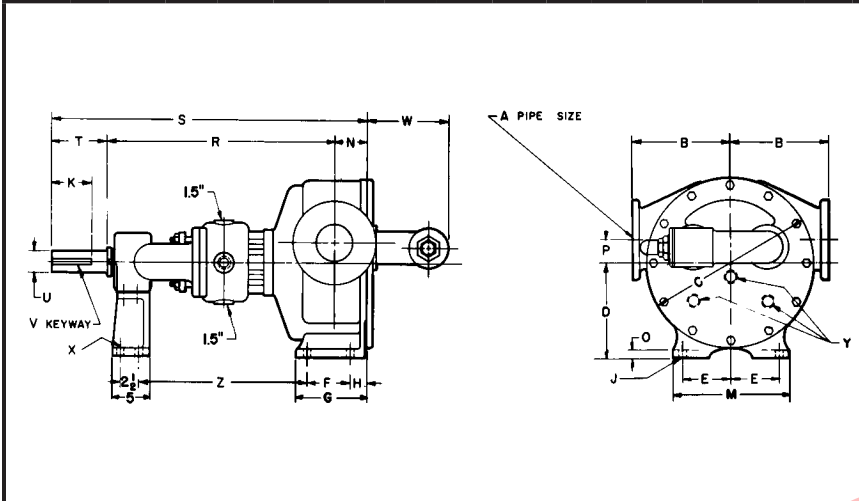

For specifications, see page 143.2.

DIMENSIONS — SERIES 335 AND 4335 UNMOUNTED PUMPS

① Flanged ports are suitable for use with 125# ANSI cast iron or 150# ANSI steel companion flanges or flanged fittings.

MODEL NO.		A	B	C	D	E	F	G	H	J	K	M	N	O	P	R	S	T	U	V	W	X	Y	Z
N335 AND N4335	in	① 6.00	9.75	17.25	9.50	5.00	6.25	8.69	1.62	.69	4.50	12.00	4.50	1.00	3.00	26.00	36.50	6.00	2.44	.62 x .31	8.50	.69	---	18.94
	mm	---	248	438	241	127	159	221	41	18	114	305	114	25	76	660	927	152	62	16 x 8	216	18	---	481
R335 AND R4335	in	① 8.00	14.25	24.50	13.25	6.75	7.00	10.56	2.31	.78	5.00	16.00	5.62	1.00	4.50	26.62	41.00	8.75	2.44	.62 x .31	11.88	.69	1.25	19.25
	mm	---	362	622	337	171	178	268	59	20	127	406	143	25	114	676	1041	222	62	16 x 8	302	18	---	495

PRODUCT 1Q16 SOLETTED