

VIKING® HEAVY DUTY PUMPS

SERIES 333 AND 4333
STEEL EXTERNALS

Section	153
Page	153.1
Issue	B

FEATURES

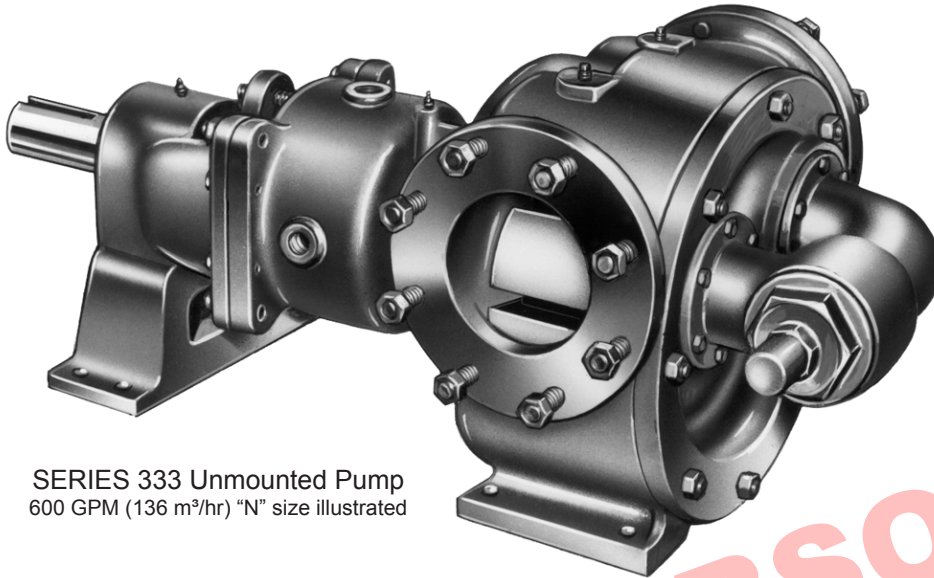

SERIES 333 Unmounted Pump
600 GPM (136 m³/hr) "N" size illustrated

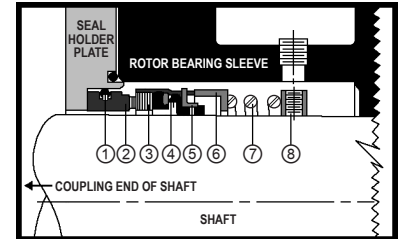

MECHANICAL SEAL — SERIES 4335

- ① Buna-N O-Ring
- ② Ni-Resist Stationary Seat
- ③ Carbon Rotating Face
- ④ Buna-N Bellows
- ⑤ Steel Metal Parts
- ⑥ Steel Spring Adapter
- ⑦ Steel Spring
- ⑧ Steel Set Collar

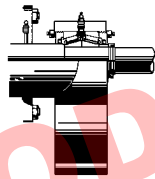

INTEGRAL THRUST BEARING (Standard Equipment)

Both sizes of the large Series 333 and 4333 Heavy-Duty pumps are equipped with pedestal supported rotor thrust bearings. This results in a fully rigid and positive alignment and eliminates the need of a second shaft support. Rotor adjustment is provided by means of two adjusting nuts.

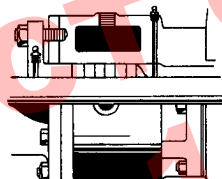

JACKETED ROTOR BEARING SLEEVE (Standard Equipment)

The "N" and "R" size Series 333 and 4333 pumps come standard equipped with a single piece, jacketed, rotor bearing sleeve. Generous jacketed area is suitable for steam or other heating or cooling media. Jacket equipped with handy steam or cooling connections.

① Pressure Range	125 PSI (9 BAR) for 100 SSU (21 cSt) and above
	75 PSI (5 BAR) for below 100 SSU (21 cSt)
① Temperature Range	-60°F. to +450°F. (-51°C. to +232°C.)
① Viscosity Range	28 to 2,000,000 SSU (1.0 to 440,000 cSt)

② G.P.M. 600 - 1100 (m³/hr 136 - 250) (Nominal Rating)

The Viking Series 333 and 4333 heavy-duty pumps with steel externals are built for bulk handling of both thin and viscous liquids. These large size pumps are popular for barge, tanker and terminal loading and unloading since pumps are fast self-priming and capable of completely stripping tanks without additional equipment.

The Series 333 (packed) and 4333 (mechanical seal) pumps as illustrated are furnished with horizontal ports. However, other port locations can be furnished on special request. Standard features include thrust bearing pedestal support and internal type safety relief valve on pump head. All are equipped with opposite 150 lb. ANSI flanged ports.

The steel used meets ASTM, A216 Grade WCB specifications.

- ① Values shown represent maximums. Some special construction or consideration may be required before a cataloged pump can be applied to an application involving the maximum pressure, temperature and/or viscosity.
- ② Nominal capacities based on handling thin liquids at low pressures.

Metric conversions are based on US measurements and rounded to the nearest whole number.

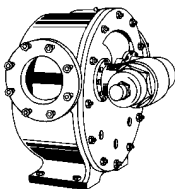

COMBINATION JACKETED AND RELIEF VALVE HEAD (Standard Equipment)

The 1100 GPM size pump in the Heavy-Duty Series 333 and 4333 features a combination jacketed and relief valve type head as standard equipment. Valve is standard and can be turned end for end when reversing pump rotation. Valve points toward suction port.

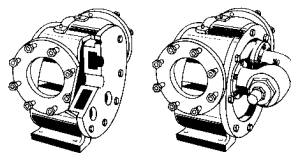

JACKETED OR RELIEF VALVE HEAD (Standard Equipment)

The "N" size 600 GPM Heavy-Duty Series 333 and 4333 pump can be furnished with a jacketed or valve type head. (Valve type standard.) Not available in combination. Generous steam chambers in jacketing permit heating of pump. See valve information at left.

Section	153
Page	153.2
Issue	B

VIKING® HEAVY DUTY PUMPS

SERIES 333 AND 4333

STEEL EXTERNALS

UNMOUNTED PUMPS

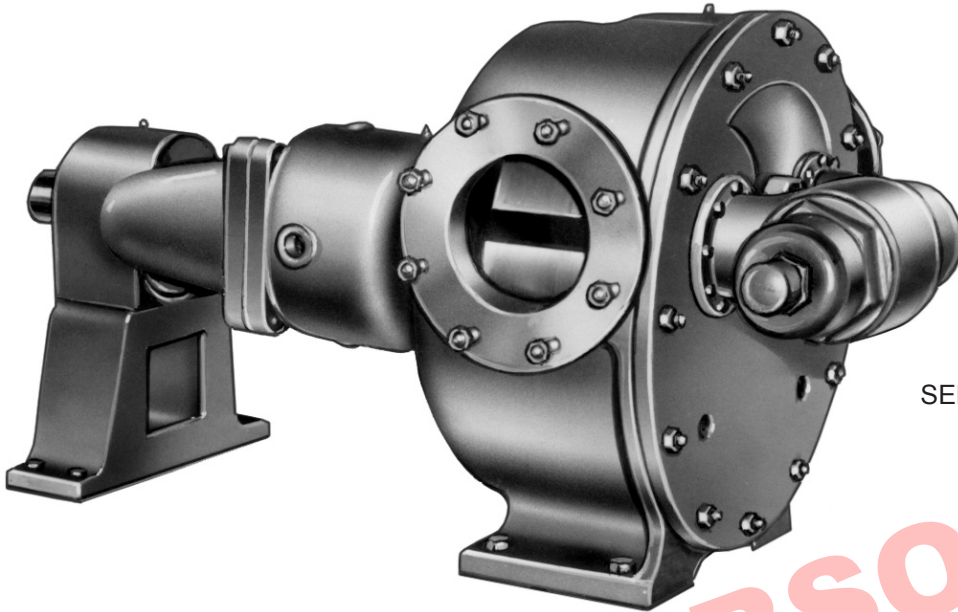

SERIES 333 Unmounted Pump
"R" size illustrated

The large capacity, steel external, heavy-duty Series 333 (packed) and 4333 (mechanical seal) pumps find many applications in the chemical, petrochemical and refining industries requiring dependable, long life pumps. Rugged steel, meeting ASTM A216 Grade WCB specifications, is found in the external parts—casing, rotor bearing sleeve, head and internal safety relief valve—to provide a pump which resists thermal shock.

allows for cooling or heating of the bushing to provide longer life to this critical pump part.

Both packed and mechanical seal types are available. The standard mechanical seal is equipped with a Buna-N elastomer shaft sealing member, carbon rotating and Ni-Resist stationary faces.

Dimensions for Unmounted Pumps—See Page 153.4.

Performance Data for Unmounted Pumps—See Pages 153.7 thru 153.12.

Generous jacketed area in the rotor bearing sleeve

CONSTRUCTION — SERIES 333 AND ① 4333 "N" AND "R" SIZES

Pump Construction	Casing	Rotor Bearing Sleeve	Head	Rotor	Idler	Rotor Shaft and Idler Pin	Bushings		Internal Relief Valve
							Packed	Mechanical Seal	
Standard Construction	Steel	Steel	Steel	② Iron	Iron	Steel	Bronze	Carbon Graphite	Steel Externals
Steel Fitted	Steel	Steel	Steel	Steel	Iron	Steel	Bronze	Carbon Graphite	Steel Externals

SPECIFICATIONS — UNMOUNTED PUMPS

Model Number	② 150 lb. ANSI Flanged Opposite Port Size	③ Nominal Pump Rating			Motor HP Required At Rated Speed Pumping 100 SSU Liquid			Maximum Hydrostatic Pressure PSIG (BAR)	④⑤⑥ Maximum Recommended Discharge Pressure Handling 100 SSU Liquid at Nominal Rated Speeds PSIG	⑦ Maximum Recommended Temperature For Cataloged Pump °F. (°C.)		Steel Fitted Construction Recommended Above This Viscosity SSU (cSt)	⑧ Maximum Temperature / Pressure of Fluids In Jackets				Approx. Shipping Weight With Valve Pounds (KG)
		Inches	GPM (m³/hr)	RPM	25 PSI (2 BAR)	50 PSI (3 BAR)	100 PSI (7 BAR)			Packed	Mech. Seal		Temp. °F. (°C.)	Pressure PSIG (BAR)	Temp. °F. (°C.)	Pressure PSIG (BAR)	
N333	N4333	6	600 (136)	350	20	30	50	400 (28)	125	300 (149)	225 (107)	75,000 (16,500)	365 (185)	150 (10)	450 (232)	150 (10)	810 (368)
R333	R4333	8	1100 (250)	280	40	50	100	400 (28)	125	300 (149)	225 (107)	25,000 (5,500)	365 (185)	150 (10)	450 (232)	150 (10)	1435 (651)

① Buna-N elastomer used in mechanical seal of Series 4333 pumps. On applications above 15,000 SSU (3,300 cSt), provide details for recommendation.

② Flanged ports are suitable for use with 150# ANSI steel companion flanges or flanged fittings.

③ Nominal capacities based on handling thin liquids at low pressure.

④ External force feed lubrication to bushings is recommended when pump might run dry or when a steam or thin liquid flush cycle is used.

⑤ For maximum recommended discharge pressures when handling other viscosities and/or at other speeds, see performance curves. Performance curves also show

preferred construction.

⑥ If suction pressure exceeds 50 PSIG (3 BAR), check factory with details.

⑦ With special construction temperatures to 450° F. can be handled. Under certain conditions higher temperature may be considered. Check factory with details.

⑧ Jacketed rotor bearing sleeve (stuffing box) is standard on both pumps. Jacketed head is available on the "N" size pump. On the "R" size a combination jacketed AND relief valve head is standard, the jacketed relief valve is not available.

⑨ "N" size has ductile iron rotor.

Metric conversions are based on US measurements and rounded to the nearest whole number.

VIKING® HEAVY DUTY PUMPS

SERIES 333 AND 4333
STEEL EXTERNALS

Section	153
Page	153.3
Issue	B

GEAR REDUCER UNITS (“P” DRIVE)

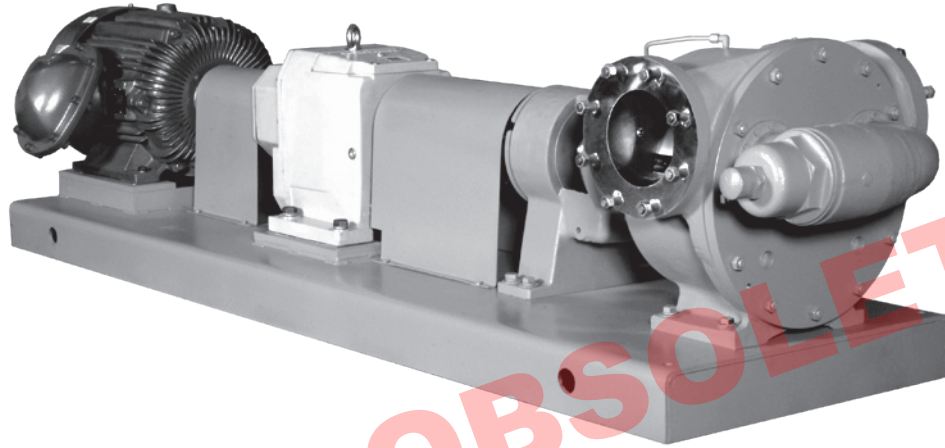

Example of Purchased Reducer Drive

The Viking Heavy-Duty Series 333 (packed) and 4333 (mechanical seal) pumps in two sizes—“N” and “R”—are available in the “P” drive arrangement.

These “P” Drive Heavy-Duty Units are mounted on structural steel bases as illustrated above. All mount the pumps with separate heavy-duty reducers and are

connected through flexible couplings between pumps, reducers and motors. Coupling guards, as illustrated are standard construction.

Dimensions for “P” Drive Units—Consult factory.

Performance Data for “P” Drive Units—See Pages 153.7 thru 153.12.

SPECIFICATIONS — “P” DRIVE

Model Number	② 150 lb. ANSI Flanged Opposite Port Size	③ Nominal Pump Rating	Motor HP Required At Rated Speed Pumping 100 SSU Liquid			Maximum Hydrostatic Pressure	④⑤⑥ Maximum Recommended Discharge Pressure Handling 100 SSU Liquid at Nominal Rated Speeds	⑦ Maximum Recommended Temperature For Cataloged Pump °F. (°C.)		Steel Fitted Construction Recommended Above This Viscosity	⑧ Maximum Temperature / Pressure of Fluids In Jackets				Approx. Shipping Weight With Valve		
			25 PSI (2 BAR)	50 PSI (3 BAR)	100 PSI (7 BAR)			PSIG (BAR)	Packed		Mech. Seal	Temp. °F. (°C.)		Pressure PSIG (BAR)			
	① Mech. Seal	Inches	GPM (m³/hr)	RPM								Temp. °F. (°C.)	Pressure PSIG (BAR)	Temp. °F. (°C.)	Pressure PSIG (BAR)	Pounds (KG)	
N333P	N4333P	6	600 (136)	350	20	30	50	400 (28)	125	300 (149)	225 (107)	75,000 (16,500)	365 (185)	150 (10)	450 (232)	150 (10)	1450 (658)
R333P	R4333P	8	1100 (250)	280	40	50	100	400 (28)	125	300 (149)	225 (107)	25,000 (5,500)	365 (185)	150 (10)	450 (232)	150 (10)	2190 (994)

① Buna-N elastomer used in mechanical seal of Series 4333 pumps. On applications above 15,000 SSU (3,300 cSt), provide details for recommendation.

② Flanged ports are suitable for use with 150# ANSI steel companion flanges or flanged fittings.

③ Nominal capacities based on handling thin liquids at low pressure.

④ External force feed lubrication to bushings is recommended when pump might run dry or when a steam or thin liquid flush cycle is used.

⑤ For maximum recommended discharge pressures when handling other viscosities

and/or at other speeds, see performance curves. Performance curves also show preferred construction.

⑥ If suction pressure exceeds 50 PSIG (3 BAR), check factory with details.

⑦ With special construction temperatures to 450° F. can be handled. Under certain conditions higher temperature may be considered. Check factory with details.

⑧ Jacketed rotor bearing sleeve (stuffing box) is standard on both pumps. Jacketed head is available on the “N” size pump. On the “R” size a combination jacketed AND relief valve head is standard, the jacketed relief valve is not available.

Metric conversions are based on US measurements and rounded to the nearest whole number.

Section	153
Page	153.4
Issue	D

VIKING® HEAVY DUTY PUMPS

SERIES 333 AND 4333

STEEL EXTERNALS

DIMENSIONS

These dimensions are average and not for construction purposes. Certified prints on request.

For specifications, see page 153.4.

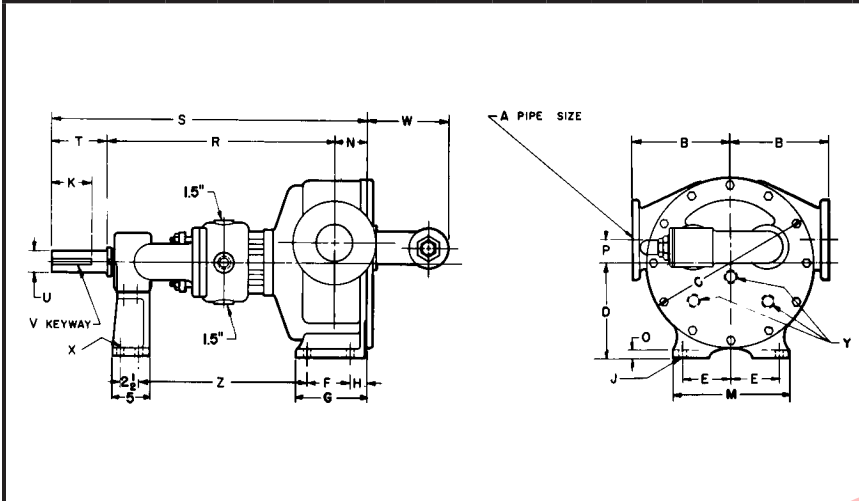

DIMENSIONS — SERIES 333 AND 4333 UNMOUNTED PUMPS

① Flanged ports are suitable for use with 150# ANSI steel companion flanges or flanged fittings.

MODEL NO.		A	B	C	D	E	F	G	H	J	K	M	N	O	P	R	S	T	U	V	W	X	Y	Z
N333 AND N4333	in	① 6.00	9.75	17.25	9.50	5.00	6.25	8.69	1.62	.69	4.50	12.00	4.50	1.00	3.00	26.00	36.50	6.00	2.44	.62 x .31	8.50	.69	0	18.94
	mm	① 152	248	438	241	127	159	221	41	18	114	305	114	25	76	660	927	152	62	16 x 8	216	18	0	481
R333 AND R4333	in	① 8.00	14.25	24.50	13.25	6.75	7.00	10.56	2.31	.78	5.00	16.00	5.62	1.00	4.50	26.62	41.00	8.75	2.44	.62 x .31	11.88	.69	1.5	19.25
	mm	① 203	362	622	337	171	178	268	59	20	127	406	143	25	114	676	1041	222	62	16 x 8	302	18	32	495