

MODELS: GB-41460-K00-D, GB-41460-K10-D, GB-41460-N00-D,
 GB-41460-N10-D, GB-41460-R00-D, GB-41460-R10-D

NOTES:

1. COUPLING GUARD NOT SHOWN IN TOP VIEW.
2. ALL DIMENSIONS ARE FOR REFERENCE ONLY.

STATE	Released	11/03/2020
DRAWN	bmanternach	11/2/2020
CHECKED	GDJ	11/03/2020

DIMENSIONS ARE IN INCHES
 PROJECT: E251
 WAS:



VIKING PUMP, INC.
 A Unit of IDEX Corporation
 Cedar Falls, IA 50613
 U.S.A.

THIS DRAWING IS THE PROPERTY OF VIKING PUMP, INC. AND IS PROPRIETARY IN GENERAL AND DETAIL. IT SHALL NOT BE COPIED OR ITS CONTENTS REVEALED TO OUTSIDE PARTIES WITHOUT THE WRITTEN CONSENT OF VIKING PUMP, INC.

3D

DWG. NO. SHEET 1 OF 1
 GPV-1460-036-U

REV. A.0
 11/03/2020



No.:

Date: 12-MAR-2015

Customer :

TECHNICAL PROPOSAL

Three-phase induction motor - Squirrel cage rotor

Product line : W22 NEMA Premium - Ball Bearings

Catalog Number : 12518ET3E444T-W22

List Price : \$ Contact Us!

Notes:

Performed by:

Checked:



No.:

Date: 12-MAR-2015

DATA SHEET

Three-phase induction motor - Squirrel cage rotor

Customer :
Product line : W22 NEMA Premium - Ball Bearings

Frame : 444/5T
Output : 125 HP
Frequency : 60 Hz
Poles : 4
Full load speed : 1780
Slip : 1.11 %
Voltage : 208-230/460 V
Rated current : 307-278/139 A
Locked rotor current : 1810/904 A
Locked rotor current (I_L/I_n) : 6.5
No-load current : 80.0/40.0 A
Full load torque : 364 lb.ft
Locked rotor torque : 200 %
Breakdown torque : 250 %
Design : B
Insulation class : F
Temperature rise : 80 K
Locked rotor time : 27 s (hot)
Service factor : 1.15
Duty cycle : S1
Ambient temperature : -20°C - +40°C
Altitude : 1000
Degree of Protection : IP55
Approximate weight : 1590 lb
Moment of inertia : 57.163 sq.ft.lb
Noise level : 73 dB(A)

	D.E.	N.D.E.	Load	Power factor	Efficiency (%)
Bearings	6319 C3	6316 C3	100%	0.85	95.4
Regreasing interval	8000 h	10000 h	75%	0.82	95.4
Grease amount	45 g	34 g	50%	0.74	95.0

Notes:

Performed by

Checked



No.:

Date: 12-MAR-2015

PERFORMANCE CURVES RELATED TO RATED OUTPUT

Three-phase induction motor - Squirrel cage rotor

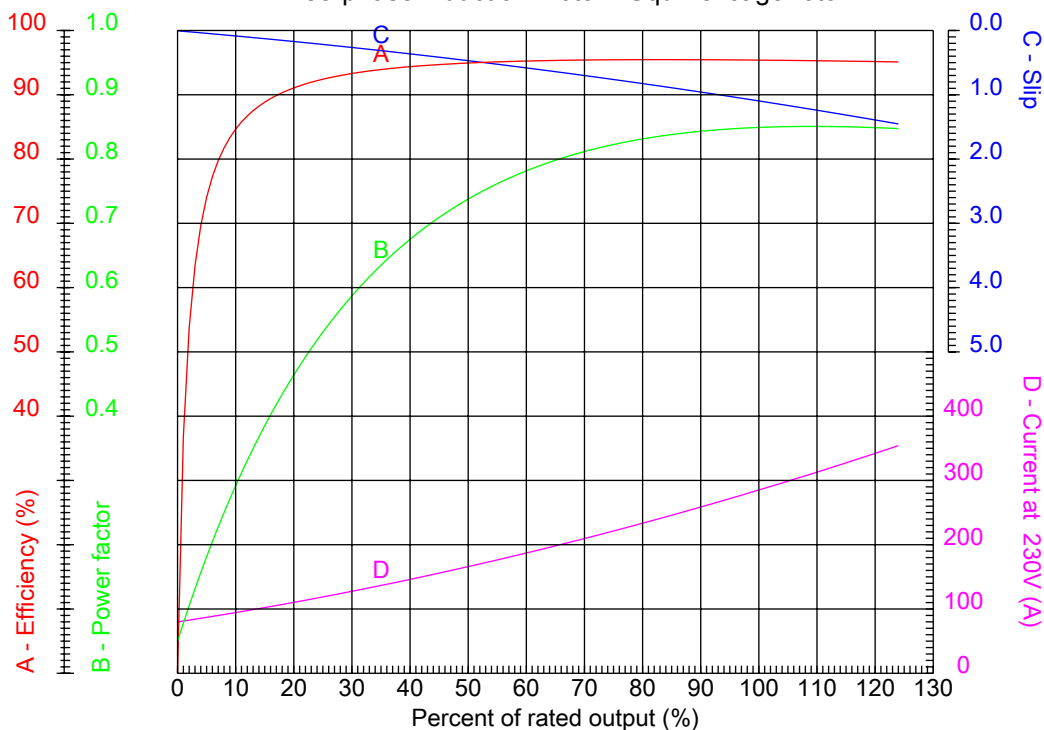

Customer :
Product line : W22 NEMA Premium - Ball Bearings

Frame : 444/5T	Locked rotor current (I _l /I _n) : 6.5
Output : 125 HP	Duty cycle : S1
Frequency : 60 Hz	Service factor : 1.15
Full load speed : 1780	Design : B
Voltage : 208-230/460 V	Locked rotor torque : 200 %
Rated current : 307-278/139 A	Breakdown torque : 250 %
Insulation class : F	

Notes:

Performed by

Checked



No.:

Date: 12-MAR-2015

CHARACTERISTIC CURVES RELATED TO SPEED

Three-phase induction motor - Squirrel cage rotor

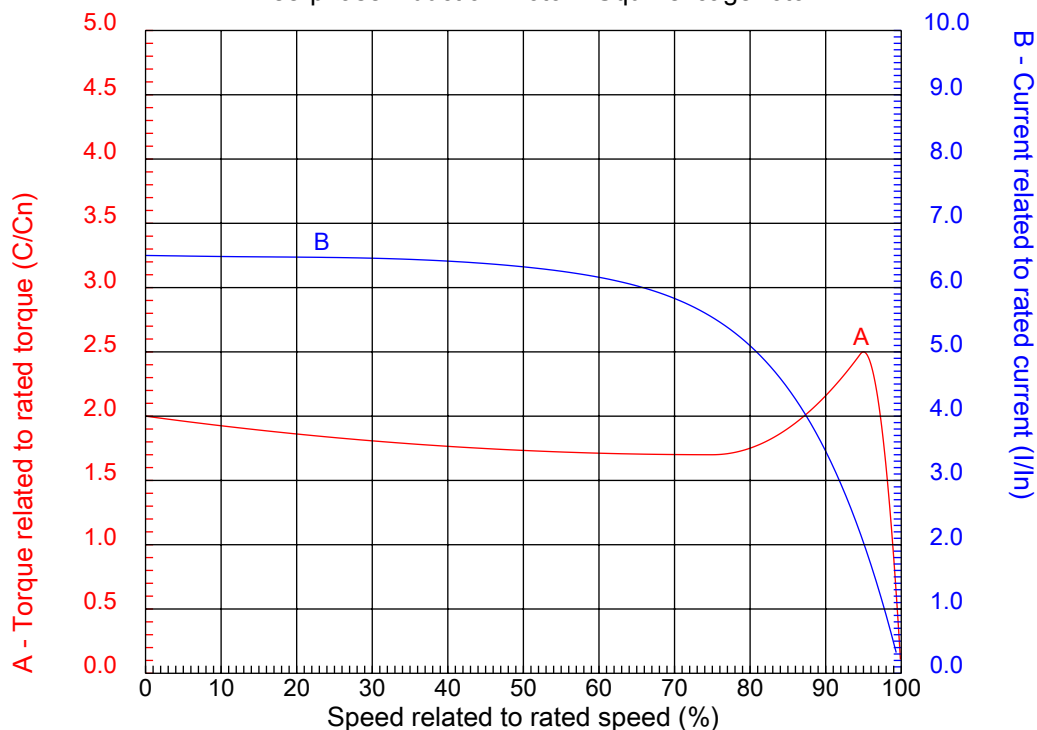

Customer :
Product line : W22 NEMA Premium - Ball Bearings

Frame	: 444/5T	Locked rotor current (I _l /I _n)	: 6.5
Output	: 125 HP	Duty cycle	: S1
Frequency	: 60 Hz	Service factor	: 1.15
Full load speed	: 1780	Design	: B
Voltage	: 208-230/460 V	Locked rotor torque	: 200 %
Rated current	: 307-278/139 A	Breakdown torque	: 250 %
Insulation class	: F		

Notes:

Performed by

Checked

1 2 3 4 5 6 7 8

A

B

C

D

E

F

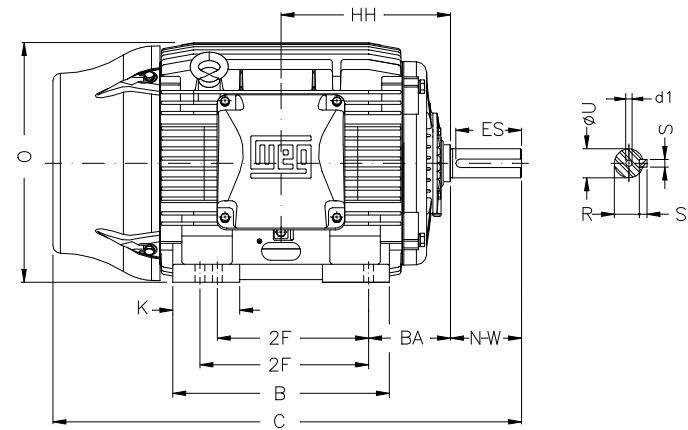
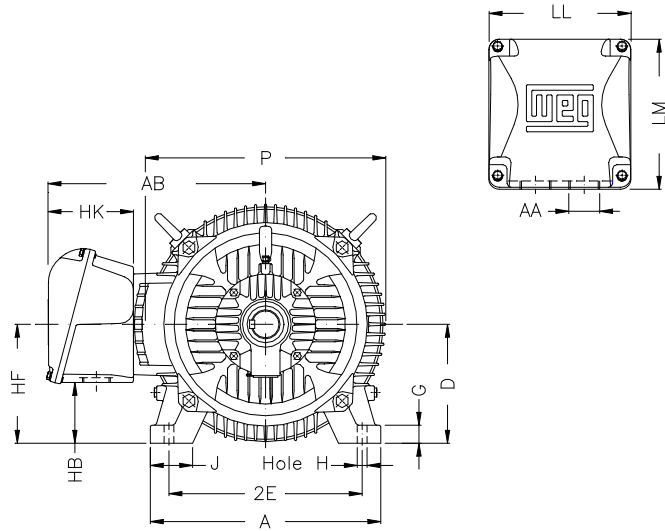

Notes:

Performed by:

Checked:

Customer:

W22 NEMA Premium - Ball Bearings

Three-phase induction motor

Frame 444/5T - IP55

12-MAR-2015



2E 18.000	J 3.937	A 21.929	P 23.583	AB 18.570
2F 14.500/16.500	K 5.866	B 20.315	BA 7.500	U 3.375
N-W 8.500	ES 7.087	S 0.875	R 2.880	depth 0.875
D 11.000	G 1.630	HB 5.687	O 22.795	HH 15.748
HK 5.970	H 0.810	C 45.157	LL 12.362	LM 12.283
AA 2xNPT 3"	d1 DUNC 3/4"-10			

1 2 3 4 5 6 7 8

A
B
C
D
E
F

LOW VOLTAGE

HIGH VOLTAGE



CONNECTIONS FOR STARTING ONLY:

LOW VOLTAGE

HIGH VOLTAGE

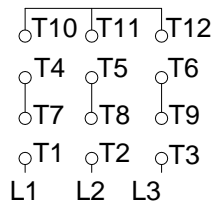
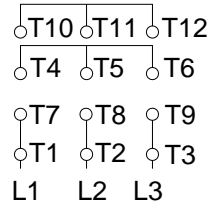

Notes:

Performed by:

Checked:

Customer:

W22 NEMA Premium - Ball Bearings

Three-phase induction motor
Frame 444/5T - IP55

12-MAR-2015

