

UNIVERSAL PRODUCT LINE: STEEL SEALLESS MAG DRIVE PUMPS

827 Series™

Section	1709
Page	1709.1
Issue	A

TABLE OF CONTENTS

Operating Range.....	1
Series Description.....	1
Features & Benefits	2
Standard Materials of Construction	3
Specifications	3
Dimensions — K, KK Sizes	4
Dimensions — LQ, LS Sizes	4
Dimensions — Q Size.....	5
Dimensions — QS Size	6
Dimensions — LQ, LS Sizes — B Reducer (MD-D R Drive)	7
Dimensions — LQ, LS Sizes — C Reducer (MD-D R Drive)	7
Dimensions — Q Size — C Reducer (MD-D R Drive)	8
Dimensions — QS Size — C Reducer (MD-D R Drive).....	8
NPSH Required	9
Selecting The Correct Viking Mag Drive® Coupling.....	10

SERIES DESCRIPTION

Viking Mag Drive is designed to provide positive displacement pumping capability in those situations that require the highest assurance of liquid containment. Viking Mag Drive provides for the safe, trouble-free transfer of hazardous, EPA-regulated fluids without electronic monitoring as required with mechanical face-type shaft seals. Hard-to-seal liquids are also easily handled with the Mag Drive which eliminates the high cost of mechanical seal replacement and repair. Top unloading of trucks and railcars, plus many other transfer applications, is ideal for these self-priming pumps with flows up to 500 GPM. The high torque available from the rare-earth magnetic coupling permits slow-speed running of the pump with gear reducer for handling viscous liquids. The internal gear design provides low-shear and nonpulsating flow.

Pumps are standard with **Hollow Shaft Circulation**. The Q and QS feature an integral jacketed pump bracket as standard. Bolt-on jacketing is available as an option for the smaller sizes. **Temperature Probe** (to monitor canister temperature) is standard for LQ, LS, Q, and QS sizes and optional on the K and KK sizes. **Silicon Carbide** bushings are optional for all Mag Drive internal gear pumps.

WARNING

The magnets in these units do not pose a hazard in the assembled state. No one with any type of medical implant should come close to the magnets of a disassembled unit. The inner magnet especially may also have adverse effects on the performance of computers, watches, credit cards, and other memory devices.

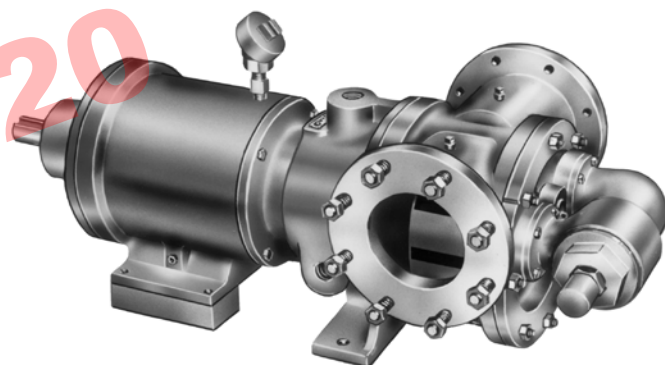

QS825

OPERATING RANGE

SERIES	NOMINAL FLOW		MAXIMUM PRESSURE		TEMPERATURE RANGE		VISCOSITY RANGE	
	GPM	m ³ h	PSI	Bar	°F	°C	SSU	cSt
827 Series™	80 - 500	18 - 114	125	9	-60 to +500	-50 to +260	28 to 250,000	0.1 to 55,000

Section	1709
Page	1709.2
Issue	A

UNIVERSAL PRODUCT LINE: STEEL SEALLESS MAG DRIVE PUMPS

827 Series™

FEATURES & BENEFITS

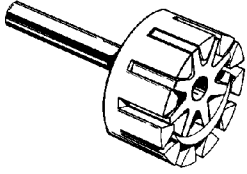

Internal Gear

With only two moving parts, Mag Drive and gear-within-a-gear principle provide low-shear pumping.

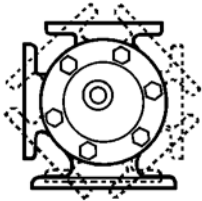

Revolvable pump casing

Most pumps are equipped so that ports can be repositioned. K and KK sizes rotate at the bracket so four positions are possible. LQ and LS (and some Q) rotate at the casing and eight positions are available. Relief valve must point to suction port in all cases.

DISCHARGE

SUCTION



Pump rotation cw standard (When viewed from shaft end)

Viking Mag Drive pumps are directional and should not be run in both directions. To change direction of rotation, consult the Technical Service Manual. Relief valve must point to suction port in all cases.

RELIEF VALVE ADJUSTING SCREW CAP

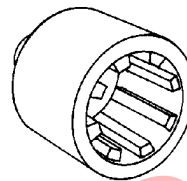

Magnetic Coupling

The Viking Mag Drive magnetically couples the pump shaft to the prime mover. Magnetic force passing through a stainless steel canister drives the inner coupling eliminating the need for dynamic shaft seals.

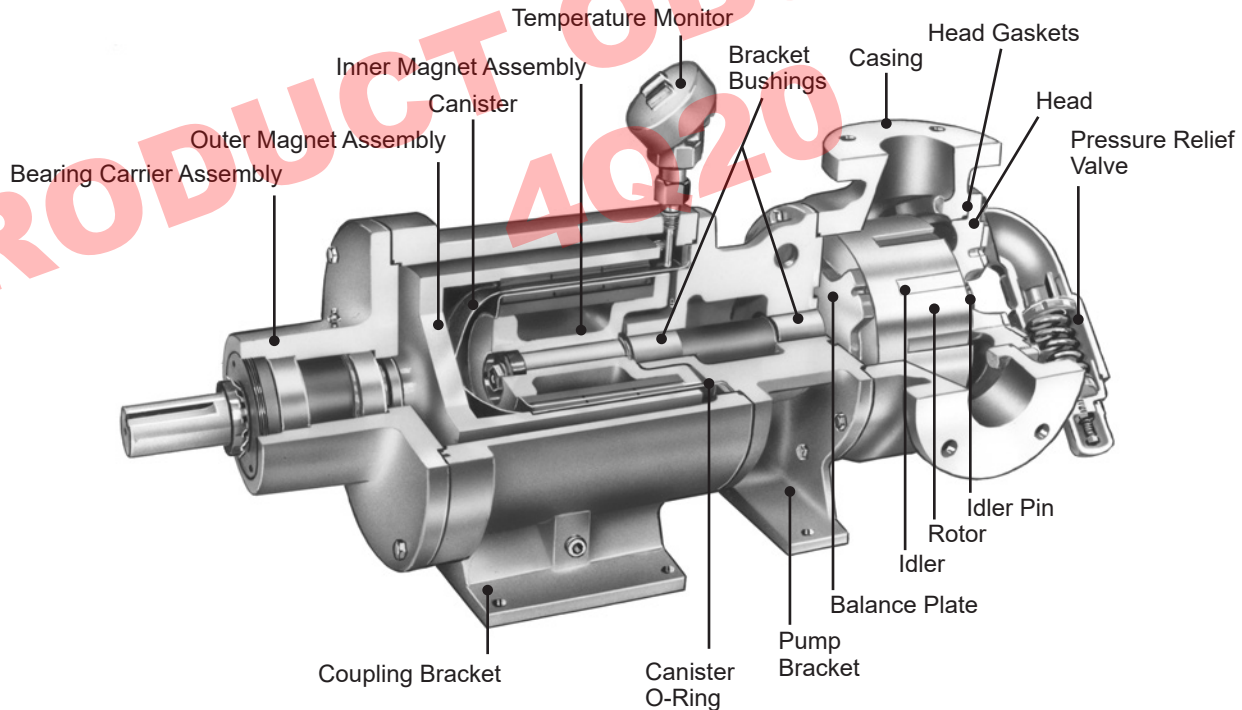

UNIVERSAL PRODUCT LINE: STEEL SEALLESS MAG DRIVE PUMPS

827 Series™

Section	1709
Page	1709.3
Issue	A

STANDARD MATERIALS OF CONSTRUCTION

Series	① Pump Construction	Bracket & Casing	Head	Rotor	Idler	Rotor Shaft	Idler Pin	Idler Bushing	Internal Pressure Relief Valve	Balance Plate
827 Series™	Stainless Steel	Stainless Steel	Stainless Steel	Stainless Steel	770 SST Alloy	Stainless Steel	Coated Stainless	Carbon Graphite	Stainless Steel	② 770 SST Alloy

① FKM O-Rings are standard. Buna-N, Neoprene, PTFE, or FFKM available.

② PPS Composite balance plate furnished in K and KK size pumps.

PPS - Reinforced polyphenylene sulfide

SPECIFICATIONS

Model Numbers Unmounted Pumps	Port Size Inches	Nominal Pump Rating GPM m ³ /h RPM			② Magnetic Coupling Availability		③ Maximum Temperature (Standard Construction)		Maximum Hydrostatic Pressure		Approximate Shipping Weight With Valve (Less Power)		
					Torque		°F	°C	PSIG	bar	Pounds	Kg	
					Series	Ft-Lbs							Nm
K827	① 2	80	18	780	MD-C	80	108	225	107	400	28	105	48
KK827	① 2	100	22	780	MD-C	80	108	225	107	400	28	110	50
LQ827	① 2½	135	31	640	MD-D	560	760	225	107	400	28	182	83
LS827	① 3	200	45	640	MD-D	560	760	225	107	400	28	225	102
Q827	① 4	300	68	520	MD-D	560	760	225	107	400	28	460	209
QS827	① 6	500	114	520	MD-D	560	760	225	107	400	28	570	259

① Ports are suitable for use with 150# ANSI steel companion flanges or flanged fittings.

② See page 1709.10 for proper sizing of torque coupling. Coupling designation begins with Series letter followed by torque rating required for application, then letter indicating drive arrangement.

③ Alternate magnet materials and/or special construction features are required at temperatures above 225° F. Consult factory for details.

Section	1709
Page	1709.4
Issue	A

**UNIVERSAL PRODUCT LINE:
STEEL SEALLESS MAG DRIVE PUMPS**
827 Series™

DIMENSIONS — K, KK SIZES

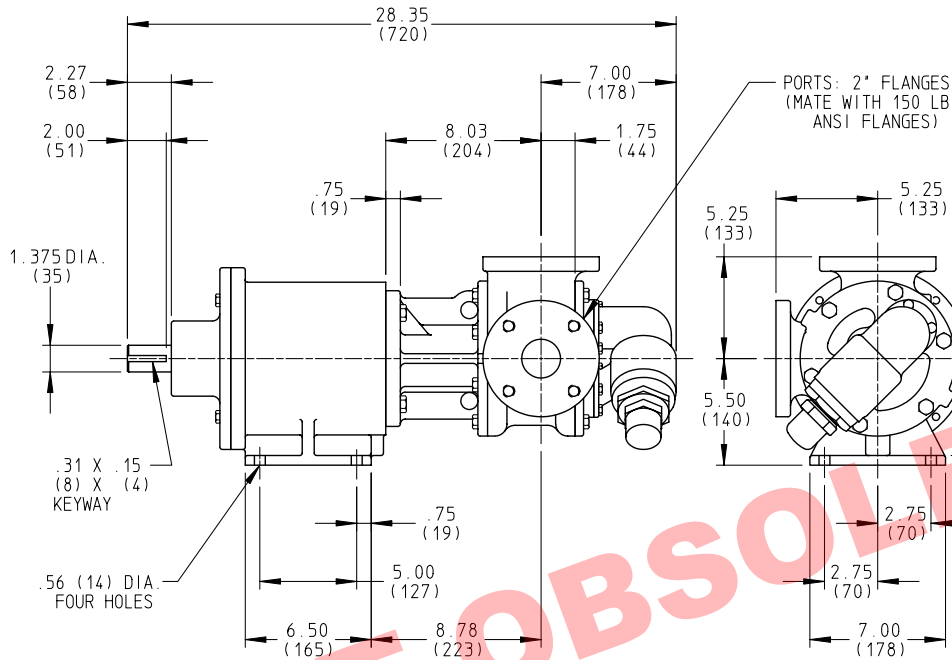

DIMENSIONS — LQ, LS SIZES

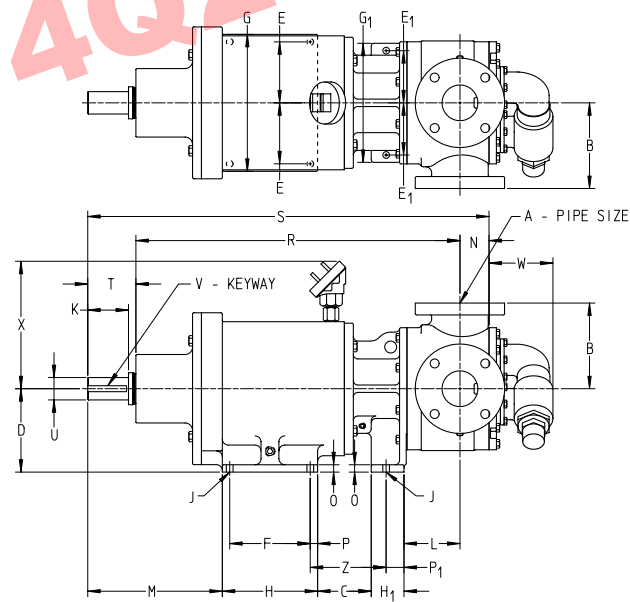

① Ports are suitable for use with 150# ANSI steel companion flanges or flanged fittings.

LQ and LS size pumps are standard with flanged ports.

MODEL NO.	A	B	C	D	E	E ₁	F	G	G ₁	H	H ₁	J	K	L	M	N	O	P	P ₁	R	S	T	U	V	W	X	Z
LQ827-MD-D-B	① in	7.19	4.50	7.00	5.12	4.38	6.75	11.50	10.00	8.00	2.75	.56	3.42	3.58	11.29	1.75	.62	.62	1.50	26.08	31.87	4.04	1.875	.50 x .25	5.38	10.70	6.38
	2½ mm	183	114	178	130	111	171	292	254	203	70	14	87	91	287	44	16	16	38	662	809	103	47.62	12.70 x 6.35	137	272	162
LS827-M-D-D-B	① in	7.19	4.50	7.00	5.12	4.38	6.75	11.50	10.00	8.00	2.75	.56	3.42	4.70	11.29	2.44	.62	.62	1.50	27.20	33.68	4.04	1.875	.50 x .25	5.19	10.70	6.38
	3 mm	183	114	178	130	111	171	292	254	203	70	14	87	119	287	62	16	16	38	691	855	103	47.62	12.70 x 6.35	132	272	162

These dimensions are average and not for construction purposes. Certified prints on request. Dimensions shown in inches; millimeters are in parentheses.

**UNIVERSAL PRODUCT LINE:
STEEL SEALLESS MAG DRIVE PUMPS**

827 Series™

Section	1709
Page	1709.5
Issue	A

DIMENSIONS — Q SIZE

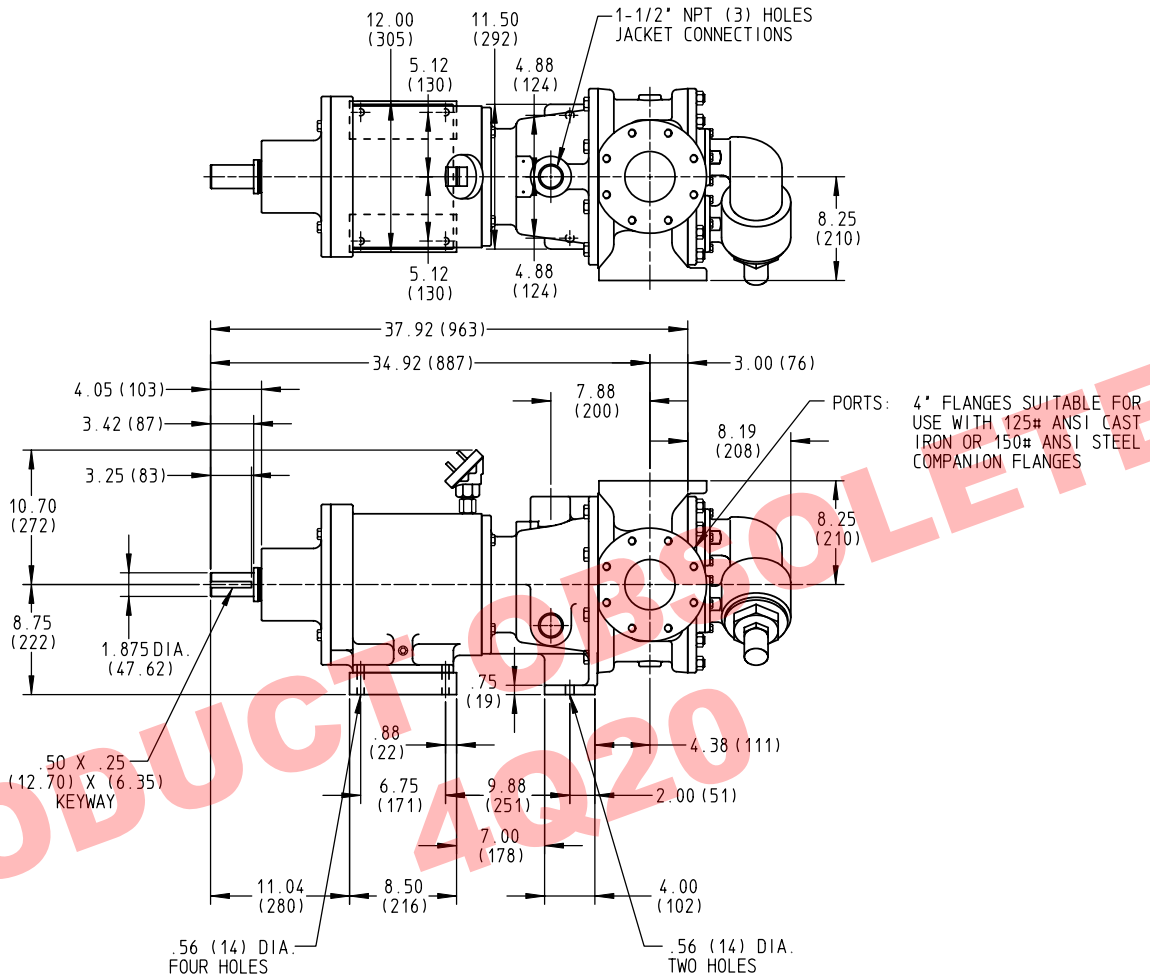

Q size pumps are standard with flanged ports.

These dimensions are average and not for construction purposes. Certified prints on request. Dimensions shown in inches; millimeters are in parentheses.

Section	1709
Page	1709.6
Issue	A

**UNIVERSAL PRODUCT LINE:
STEEL SEALLESS MAG DRIVE PUMPS**
827 Series™

DIMENSIONS — QS SIZE

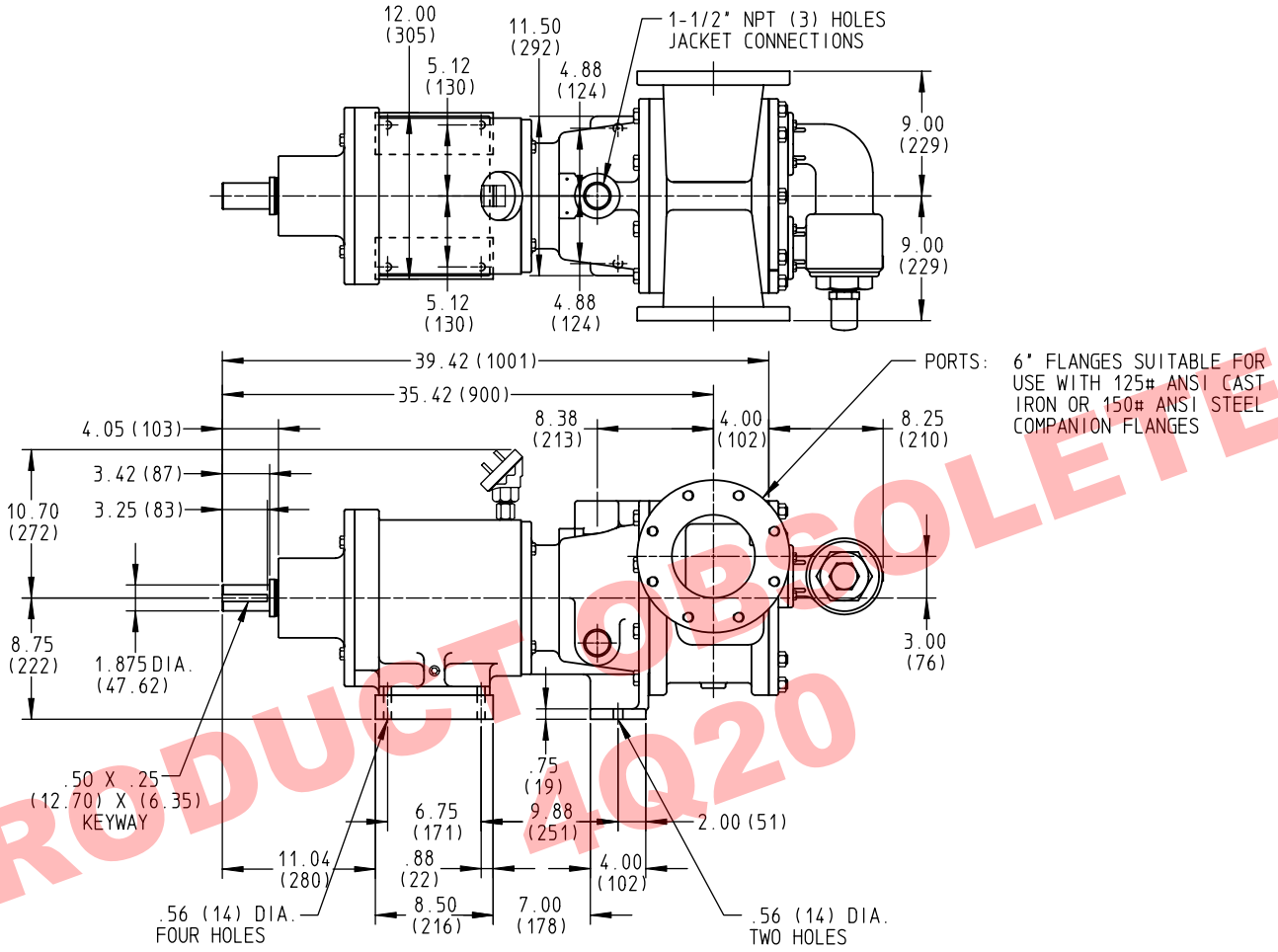

QS size pumps are standard with flanged ports.

These dimensions are average and not for construction purposes. Certified prints on request. Dimensions shown in inches; millimeters are in parentheses.

**UNIVERSAL PRODUCT LINE:
STEEL SEALLESS MAG DRIVE PUMPS**

827 Series™

Section	1709
Page	1709.7
Issue	A

DIMENSIONS — LQ, LS SIZES — B REDUCER (MD-D R DRIVE)

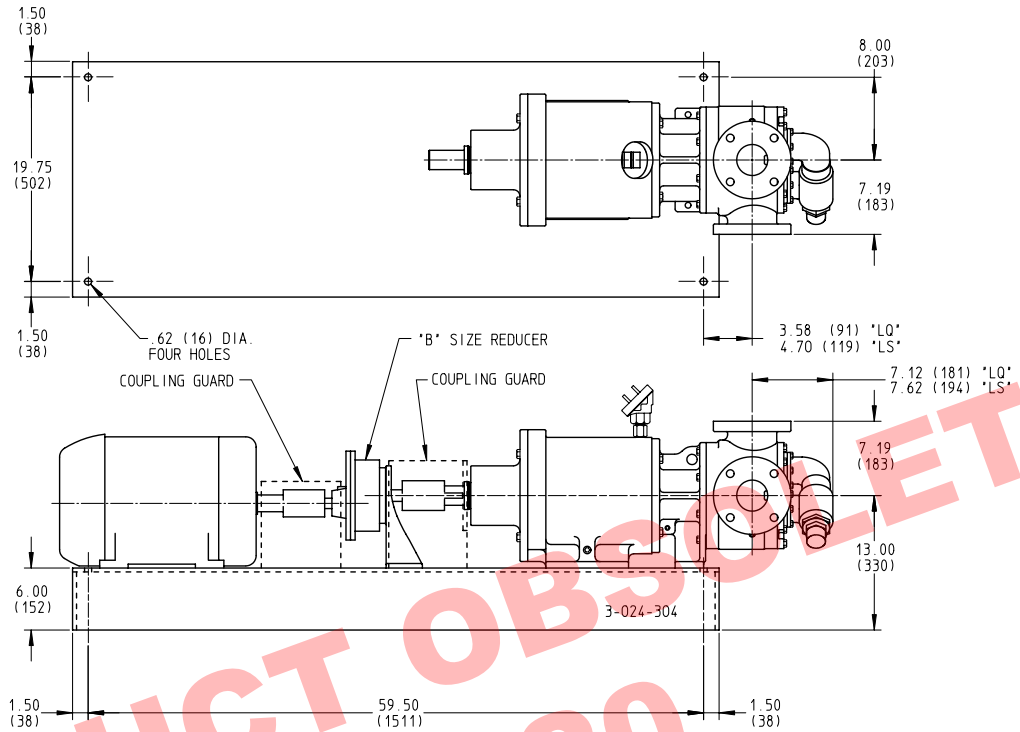

DIMENSIONS — LQ, LS SIZES — C REDUCER (MD-D R DRIVE)

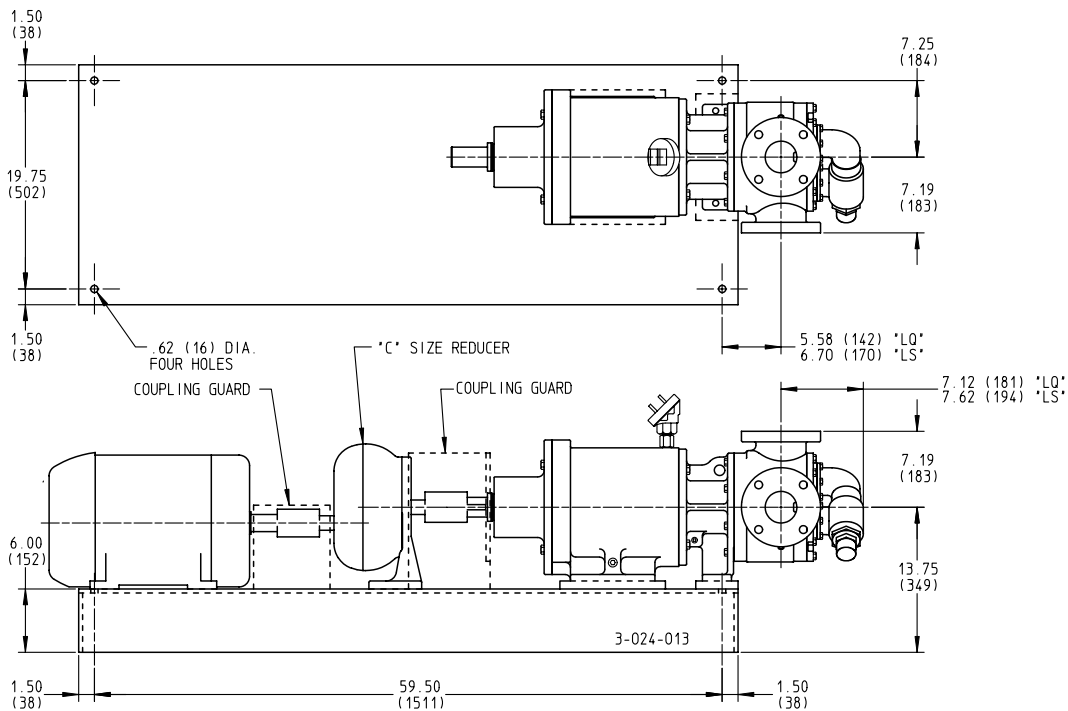

These dimensions are average and not for construction purposes. Certified prints on request. Dimensions shown in inches; millimeters are in parentheses.

Section	1709
Page	1709.8
Issue	A

**UNIVERSAL PRODUCT LINE:
STEEL SEALLESS MAG DRIVE PUMPS**
827 Series™

DIMENSIONS — Q SIZE — C REDUCER (MD-D R DRIVE)

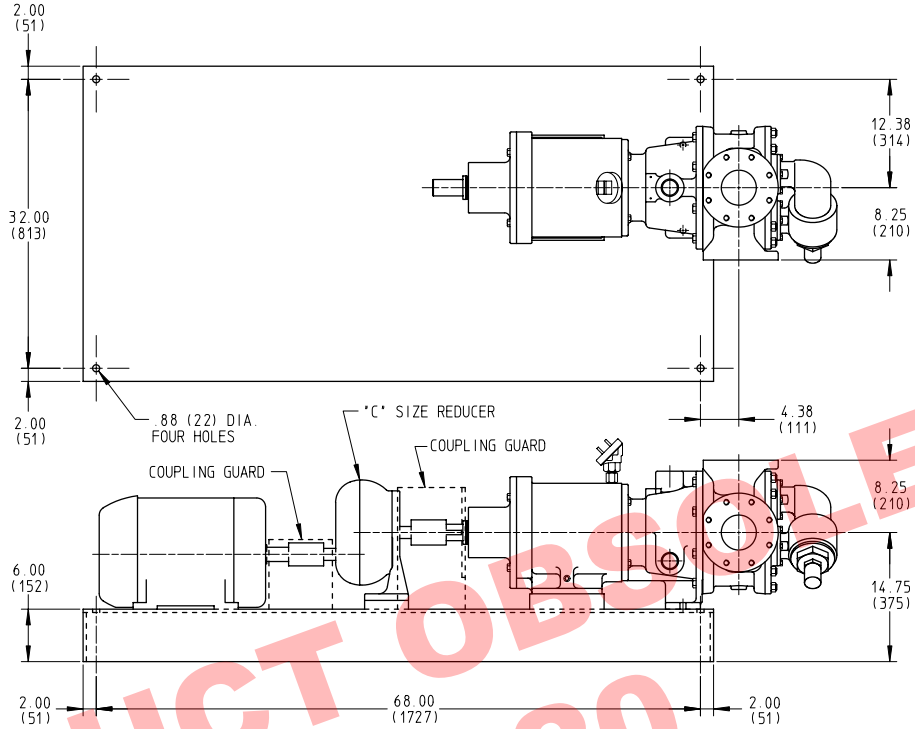

DIMENSIONS — QS SIZE — C REDUCER (MD-D R DRIVE)

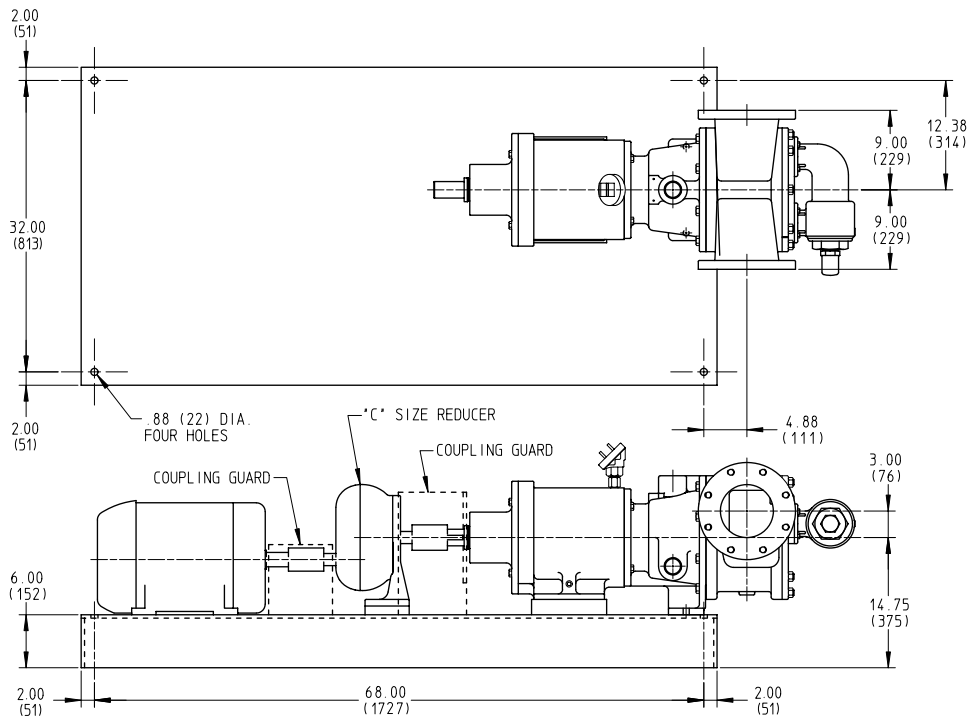

These dimensions are average and not for construction purposes. Certified prints on request. Dimensions shown in inches; millimeters are in parentheses.

**UNIVERSAL PRODUCT LINE:
STEEL SEALLESS MAG DRIVE PUMPS**

827 Series™

Section	1709
Page	1709.9
Issue	A

NPSH REQUIRED

Printed performance curves are not available.

Performance curves can be electronically generated with the Viking Pump Curve Generator on vikingpump.com.

NPSH_R data is not available on the curve generator.

NPSH (Net Positive Suction Head): The NPSH_R (Net Positive Suction Head Required by the pump) is given in the table below and applies for viscosities through 750 SSU. NPSH_A (Net Positive Suction Head – Available in the system) must be greater than the NPSH_R. For a complete explanation of NPSH, see Application Data Sheet AD-19.

FOR VISCOSITIES UP TO 750 SSU – See NPSH_R table below.

NPSH_R for high viscosities can be estimated using the following method:

1. Calculate line loss for a 1 foot long pipe of a diameter matching the pump inlet port size. Use your flow rate and max viscosity.
2. Convert this value into Feet of Liquid (S.G. 1.0)
3. Add this value to the NPSH_R value in the chart below.

PUMP SIZE	PUMPS SPEED, RPM							
	155	230	280	350	420	520	640	780
K, KK	1.8	2.1	2.3	2.8	3.3	4.4	6.3	9.1
LQ	2.0	2.5	3.0	3.8	5.0	7.3	10.8	—
LS	2.0	2.5	3.0	3.8	5.0	7.3	10.8	—
Q, QS	2.3	3.3	4.2	6.1	8.4	12.7	—	—

NPSH_R – FEET OF LIQUID (Specific Gravity 1.0), Viscosities up to 750 SSU

Section	1709
Page	1709.10
Issue	A

**UNIVERSAL PRODUCT LINE:
STEEL SEALLESS MAG DRIVE PUMPS**
827 Series™

SELECTING THE CORRECT VIKING MAG DRIVE® COUPLING

1. Find pump HP and speed from the performance curves, which can be electronically generated with the Viking Pump Selector Program, located on www.vikingpump.com.
2. Calculate the application torque (T), using this formula:

$$T \text{ (FT-LB)} = \frac{\text{HP}}{\text{SPEED}} \times 5252$$
3. Select the temperature correction factor (TCF) from Table 1 or Table 2.

STANDARD NEODYMIUM MAGNETS (For Application Temperatures Below 225°F.)							
Application Temp. (°F)	AMB	100	125	150	175	200	225
TCF	1.0	0.94	0.88	0.82	0.76	0.70	0.64

Table 1: Temperature Correction Factors

OPTIONAL SAMARIUM COBALT MAGNETS (For Application Temperatures Above 225°F.)					
Application Temp. (°F)	175	200	300	400	500
TCF	0.74	0.73	0.69	0.63	0.59

Table 2: Temperature Correction Factors

4. Divide calculated application torque by TCF to get adjusted application torque.
5. Select coupling with rating equal to or greater than "adjusted application torque" from Table 3.

MAGNETIC COUPLING TORQUE CAPACITY TABLE	
① Coupling Size	Torque (FT-LBS)
MD-C80	80
MD-D175	175
MD-D360	360
MD-D560	560

Table 3

Example 1

1. A KK827 is required to pump a 100 SSU liquid at 780 RPM, 100 PSI differential pressure.
Temperature is 100°F.
From the curve generator, required HP is 8.8.
2. Calculate torque (T).

$$\text{TORQUE (T)} = \frac{8.8}{780} \times 5252 = 59.3 \text{ FT-LB}$$
3. Since the Temperature is below 225°F., standard neodymium magnets will be used. Use Table 1 to determine the Temperature Correction Factor (TCF) = 0.94.
4. Calculate adjusted application torque.

$$\text{ADJUSTED APPLICATION TORQUE} = \frac{59.3}{0.94} = 63 \text{ FT-LB}$$

5. Verify that the adjusted torque value is less than 80.
A STANDARD NEODYMIUM MD-C80 COUPLING IS THE PROPER SELECTION

Example 2

1. A K827 is required to pump a 2500 SSU liquid at 520 RPM, Delivering 59 GPM at 75 PSI differential pressure.
Temperature is 300°F.
From the curve generator, required HP is 5.3.
2. Calculate torque (T).

$$\text{TORQUE (T)} = \frac{5.3}{520} \times 5252 = 53.5 \text{ FT-LB}$$
3. With an operating temperature above 225°F., samarium magnets will be required. Use Table 2 to determine the Temperature Correction Factor (TCF) = 0.69.
4. Calculate adjusted application torque.

$$\text{ADJUSTED APPLICATION TORQUE} = \frac{53.9}{0.69} = 78 \text{ FT-LB}$$

5. Verify that the adjusted torque value is less than 80.
AN MD-C80 WITH OPTIONAL SAMARIUM COBALT MAGNETS IS THE PROPER SELECTION