



TECHNICAL SERVICE MANUAL

HEAVY-DUTY REFRIGERATION AMMONIA PUMPS

SERIES 4925

SIZES HL - LL

SECTION	TSM 420
PAGE	1 OF 18
ISSUE	F

CONTENTS

Installation, General Comments	1
Pump Installation	3
Preventative Maintenance	4
Safe Practices.	5
Venting the Pump	5
Disassembly	7
Assembly	10
Thrust Bearing Adjustment	11
Installation of Carbon Graphite Bushings	12
Pressure Relief Valve Instructions	12
Troubleshooting	15
Ammonia	16

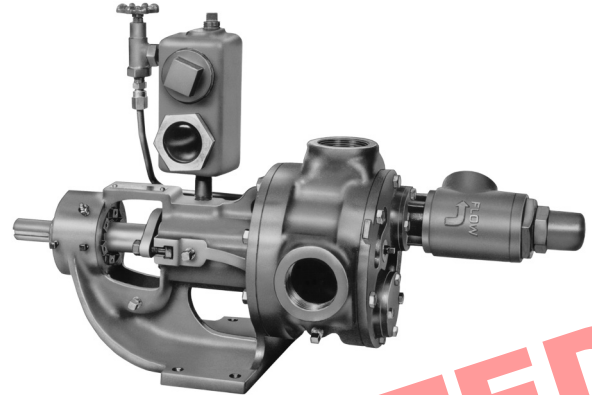

FIGURE 1
Series 4925 Unmounted Pump

INTRODUCTION

The illustrations in this manual are for identification purposes only and cannot be used for ordering parts. Obtain a parts list from the factory or a Viking® representative. Due to the nature of the pump and the close manufacturing tolerances, certain replacement parts are only available in assemblies. Always give complete name of part, part number, and material with the model number and serial number of pump when ordering repair parts. The pump or pump unit model number and serial number are on the nameplate.

In the Viking® model number system, the basic size letters are combined with the series (4925) indicating either an unmounted pump or mounted pump unit.

UNMOUNTED PUMP & UNIT MODEL NUMBERS

UNMOUNTED	UNITS
MECH. SEAL	Units are designated by the unmounted pump model numbers followed by a letter(s) indicating drive style. V = V-Belt R = Viking Speed Reducer P = Commercial Speed Reducer
HL4925	
K4925	
KK4925	
LQ4925	
LL4925	

This manual deals exclusively with Series 4925 Heavy Duty Refrigeration Ammonia Pumps. Refer to Figures 1 thru 24 for general configuration and nomenclature used in this manual. **NOTE: DO NOT OPERATE SERIES 4925 PUMPS AT SPEEDS HIGHER THAN THOSE STATED IN CATALOG SECTION 420** (Series 4925 Heavy Duty Refrigeration Ammonia Pumps).

NOTE: Single reservoir sight glass is standard. Images are shown with optional reservoir fittings.

INSTALLATION, GENERAL COMMENTS

Consideration of the following points during design and installation of the system will help ensure successful operation of the Viking Refrigeration Ammonia Pump.

- SUBMERGENCE** - Submergence is the head of liquid ammonia above the centerline of the pump suction port. A liquid head is necessary to keep the ammonia from flashing as it goes into the pump. The minimum liquid head or submergence for good pump operation is 4 feet; this is assuming a large, short suction line.
- SUCTION LINE** - A large, short suction line is necessary for good operation. A good suction line:
 - is a suction line that is at least one size larger than the pump suction port connection,
 - is connected to the pump by an eccentric reducer (with the offset or eccentric portion down) when suction to the pump is horizontal,
 - is as short as practical for the installation,
 - has no strainer (sometimes a temporary strainer is used during start up to keep weld beads, etc., from going through the pump),
 - uses a long sweep elbow if any elbow is unnecessary,
 - has a full flow shut off valve,
 - and is fully insulated to prevent heat pickup.
- INSULATION** - Insulation on the suction line and on the pump helps reduce the amount of heat pickup by the liquid ammonia.

SAFETY INFORMATION AND INSTRUCTIONS

IMPROPER INSTALLATION, OPERATION OR MAINTENANCE OF PUMP MAY CAUSE SERIOUS INJURY OR DEATH AND/OR RESULT IN DAMAGE TO PUMP AND/OR OTHER EQUIPMENT. VIKING'S WARRANTY DOES NOT COVER FAILURE DUE TO IMPROPER INSTALLATION, OPERATION OR MAINTENANCE.

THIS INFORMATION MUST BE FULLY READ BEFORE BEGINNING INSTALLATION, OPERATION OR MAINTENANCE OF PUMP AND MUST BE KEPT WITH PUMP. PUMP MUST BE INSTALLED, OPERATED AND MAINTAINED ONLY BY SUITABLY TRAINED AND QUALIFIED PERSONS.

THE FOLLOWING SAFETY INSTRUCTIONS MUST BE FOLLOWED AND ADHERED TO AT ALL TIMES.

Symbol Legend :



Danger - Failure to follow the indicated instruction may result in serious injury or death.

WARNING

Warning - In addition to possible serious injury or death, failure to follow the indicated instruction may cause damage to pump and/or other equipment.



BEFORE opening any liquid chamber (pumping chamber, reservoir, relief valve adjusting cap fitting, etc.) be sure that :

- Any pressure in the chamber has been completely vented through the suction or discharge lines or other appropriate openings or connections.
- The pump drive system means (motor, turbine, engine, etc.) has been "locked out" or otherwise been made non-operational so that it cannot be started while work is being done on the pump.
- You know what material the pump has been handling, have obtained a material safety data sheet (MSDS) for the material, and understand and follow all precautions appropriate for the safe handling of the material.

WARNING

INSTALL pressure gauges/sensors next to the pump suction and discharge connections to monitor pressures.



WARNING

USE extreme caution when lifting the pump. Suitable lifting devices should be used when appropriate. Lifting eyes installed on the pump must be used **only** to lift the pump, **not** the pump with drive and/or base plate. If the pump is mounted on a base plate, the base plate must be used for all lifting purposes. If slings are used for lifting, they must be safely and securely attached. For weight of the pump alone (which does not include the drive and/or base plate) refer to the Viking Pump product catalog.



BEFORE operating the pump, be sure all drive guards are in place.



DO NOT attempt to dismantle a pressure relief valve that has not had the spring pressure relieved or is mounted on a pump that is operating.



DO NOT operate pump if the suction or discharge piping is not connected.



AVOID contact with hot areas of the pump and/or drive. Certain operating conditions, temperature control devices (jackets, heat-tracing, etc.), improper installation, improper operation, and improper maintenance can all cause high temperatures on the pump and/or drive.



DO NOT place fingers into the pumping chamber or its connection ports or into any part of the drive train if there is **any possibility** of the pump shafts being rotated.



WARNING

THE PUMP must be provided with pressure protection. This may be provided through a relief valve mounted directly on the pump, an in-line pressure relief valve, a torque limiting device, or a rupture disk. If pump rotation may be reversed during operation, pressure protection must be provided on **both** sides of pump. Relief valve adjusting screw caps must always point towards suction side of the pump. If pump rotation is reversed, position of the relief valve must be changed. Pressure relief valves cannot be used to control pump flow or regulate discharge pressure. For additional information, refer to Viking Pump's Technical Service Manual TSM 000 and Engineering Service Bulletin ESB-31.



WARNING

DO NOT exceed the pumps rated pressure, speed, and temperature, or change the system/duty parameters from those the pump was originally supplied, without confirming its suitability for the new service.



WARNING

BEFORE operating the pump, be sure that:

- It is clean and free from debris
- All valves in the suction and discharge pipelines are fully opened.
- All piping connected to the pump is fully supported and correctly aligned with the pump.
- Pump rotation is correct for the desired direction of flow.



WARNING

THE PUMP must be installed in a matter that allows safe access for routine maintenance and for inspection during operation to check for leakage and monitor pump operation.

4. **PUMP SPEED** - The slower the operating speed, the longer the service life. This is particularly true on refrigeration ammonia pumps where:
 - 4.1. the liquid has virtually no lubrication value or film strength to prevent surface to surface contact.
 - 4.2. the heat generated by friction can cause the ammonia to vaporize, which in turn causes cavitation.
5. **TESTING** - All Viking Ammonia pumps are tested prior to shipment, but it is good practice to pressure test the pump along with the rest of the system before adding the ammonia. Shipping, storage, and installation all have strange ways of producing detrimental effects on sound equipment.
6. **SYSTEM CLEANLINESS** - Ammonia is a good detergent, as such it has a tendency to remove all the dirt, pipe scale, weld beads, and loose or foreign material in the system. Unfortunately, not all of this material settles out in traps or can be caught in strainers; and as a result, a considerable amount goes through the pump. The abrasive solids going through the pump will cause excessive wear during the start up of a new system. Thus the cleaner a new system is before start up, the less wear and trouble with the pump.
7. **STAND BY EQUIPMENT** - Stand by equipment is always good insurance when possible breakdown of any single piece of equipment could jeopardize the operation of the entire system. Often on circulating systems, two pumps are used with operation of the pumps alternated by day or week. Alternating operation of the pumps is not always considered the best practice since both pumps may both wear out at the same time. If operation of the pumps is not alternated, the stand by pump should be run for several hours at least once a month to make sure it is in good operating condition. Sometimes on large systems three pumps are used; two running continuously with the third for use as a standby and for peak loads.

PUMP INSTALLATION

One of the most important considerations on any circulation Refrigeration Ammonia pump installation is proper design of the pump inlet line. Refrigeration Ammonia, when stored in a closed container, will exert a pressure within the container equal to its saturated vapor pressure. The saturated vapor pressure of a liquid may be defined as the pressure at which both liquid and vapor exist in equilibrium in the same container. The vapor pressure has a different value for each temperature. The saturated vapor pressure of water at 212°F (water's boiling point) is 14.7 PSIA. In other words, when handling Refrigeration Ammonia, we are handling a liquid, which is at its boiling point. A slight reduction in the pressure being exerted on the liquid will cause boiling and thus vapor formation.

With this information in mind let us examine **figure 2**, which illustrates one of the most important considerations when installing a pump to handle Refrigeration Ammonia.

The pressure (P1) in the accumulator is equal to the saturated vapor pressure of the ammonia. When the pump is not running, the pressure (P2) at the pump inlet is equal to the tank pressure (P1) plus the static head (H). $P_2 = P_1 + H$

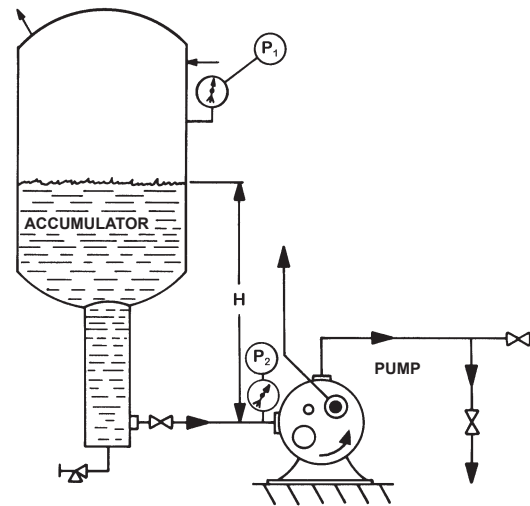

FIGURE 2

As soon as the pump is started and the liquid begins to flow, the pressure at the pump (P2) will drop by an amount equal to the pressure loss in the piping between the accumulator and the pump. When liquid is flowing: $P_2 = P_1 + H -$ (pressure loss in the piping).

In order to have an installation in which the pump handles all liquid and no vapor, the pressure drop in the piping must be equal to or less than the static head (H) on the pump inlet. If the piping loss is greater than the static head, the liquid ammonia will start to boil or vaporize, and the pump will be required to take in a mixture of liquid and vapor. Since a given weight of vapor takes up a much greater volume than the same weight of liquid, handling both liquid and vapor will reduce the liquid output from the pump. The vapor is compressed back to a liquid on the discharge side of the pump causing it to be noisy and to wear rapidly.

Values for pipe friction losses for calculating suction line pressure drop can be found in refrigeration hand books.

Since Viking pumps are of the positive displacement type, be sure that there is no obstruction in the discharge line and that all valves are in operating position before starting the pump. Factory assembled port orientation will have right hand port suction and top port discharge unless otherwise specified. Port location is determined by looking at shaft end of pump. The pressure relief valve on the pump provides over pressure protection. Return-to-Tank pressure relief valves should be mounted on the discharge side of the pump. Internal type pressure relief valves should be mounted with the cap pointing towards the suction side of pump. Also see information under **Relief Valve Instructions, page 12**. The Viking pump mounted return-to-tank pressure relief valve (see **Figure 18, page 12 & Figures 19, 20, and 21, page 13**) is fitted with a pressure relief plug to keep a valid off return line from building up excessive pressures.

DANGER !

Include provision for a pressure relief device in any part of a pump and piping system that can be valved off and, thus, completely isolated. Cold liquid ammonia when isolated will, as it warms up to room temperature, expand and exert tremendous pressures which may rupture the pump or piping unless relieved.

See Viking Technical Service Manual TSM000 for additional general installation information.

PREVENTATIVE MAINTENANCE

Series 4925 pumps are designed for long, trouble free life under a wide variety of application conditions with a minimum of maintenance. However, the following should be considered:

1. **LUBRICATION - 1.1.** Periodic external lubrication should be applied slowly with a hand gun at all lubrication fittings.

A good quality multi-purpose, polyurea, NLGI #2 grease is satisfactory in the majority of cases, however, applications involving very low temperatures may require other types of lubricants. Suggested frequency of lubrication is once every 500 hours of operation. Refer to Engineering Service Bulletin ESB-515. Consult the factory if you have specific lubrication questions.

- 1.2. **Double Mechanical Seal Reservoir:** The Series 4925 ammonia pumps are shipped without oil in the reservoir. Before letting ammonia into a new or rebuilt pump, fill the reservoir with one pint of light Refrigeration Oil that is compatible with the Neoprene seal and has a maximum viscosity of 15,000 SSU at operating temperature.

Before opening valves and allowing ammonia to fill the pump be sure the hand valve on the reservoir, shown in figure 9, is open.

Change the oil in your double seal pump reservoir after the first 200 hours of operation and then every 1000 hours of operation by the method mentioned below:

- A. Stop pump and close hand valve on oil reservoir, see figure 9.

DANGER !

Be sure ammonia pressure in pump is not above 5 PSIG when filling reservoir. If pressure is higher, pumping chamber should be bled down to reduce pressure to 5 PSIG or below. (Before bleeding pump, read SAFE PRACTICES on page 5 and VENTING THE PUMP on pages 5 and 6). Pressure above 5 PSIG in the pump may cause inner seal seat to be unseated or may force the faces of the inner seal apart allowing any dirt accumulated around the inner seat to be forced between the faces, which may cause the seal to leak when the pump is started.

- B. Remove ½ inch NPT oil filler plug in top of reservoir carefully and allow the small amount of ammonia trapped in the reservoir to vent.
- C. Open oil drain plug and allow old oil to drain.
- D. Replace oil drain plug and fill reservoir with light Refrigeration Oil to within 1½ inch of the top (approximately 1 pint).
- E. Replace ½ inch NPT oil filler plug in top of reservoir.
- F. Open hand valve.
- G. Wait one minute then start the pump and allow it to run from two to three minutes before the liquid is introduced into the pump. This will allow the seat to seal itself properly before the pressure is applied.

NOTE: If your pump has an automatic snap on filler valve arranged similar to that shown in figure 3, it is not necessary to stop the pump to add oil to the reservoir. Merely connect lubrication pump to automatic filler valve. Open manual valve and fill reservoir with light Refrigeration Oil to approximately 1½ inch from the top. Close manual valve and remove lubrication pump from filler valve. To change oil: proceed as indicated in steps A thru G except vent pumping chamber to atmosphere before changing oil.

2. **END CLEARANCE ADJUSTMENT** - After long term operation, it is sometimes possible to improve the performance of a pump, without major repair, through adjustment of the end clearance of the pump. Refer to instruction under Thrust Bearing Adjustment, page 11, for information regarding this procedure.

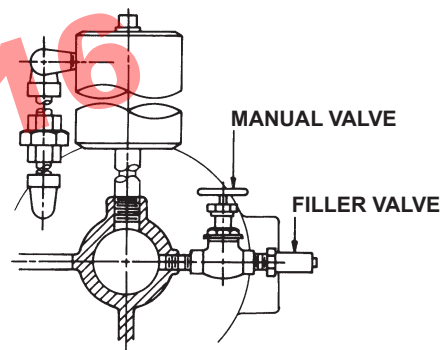

FIGURE 3

3. **CLEANING THE PUMP** - It is good practice to keep the pump as clean as possible. This will facilitate inspection, adjustment, and repair work and help prevent overlooking a dirt covered grease fitting.
4. **STORAGE** - If pump is to be stored or not used for six months or more, pump must be drained and a light coat of light oil must be applied to all internal pump parts.

Lubricate fittings and apply grease to pump shaft extension. Viking suggests rotating pump shaft by hand one complete revolution every 30 days to circulate the oil. Tighten all pump assembly bolts before putting pump in service after being stored.

MAINTENANCE

IMPORTANT: READ THE FOLLOWING BEFORE REMOVING A PUMP FROM AN AMMONIA SYSTEM OR BEFORE STARTING REPAIR WORK ON A PUMP.

DANGER !

Before opening any Viking pump liquid chamber (pumping chamber, reservoir, etc.) Be sure:

1. That any pressure in the chamber has been completely vented through the suction or discharge lines or other appropriate openings or connections. (See detailed procedure for venting the pumps, pages 5 and 6).
2. That the driving means (motor, turbine, engine, etc.) has been "locked out" or otherwise made non-operational so that it cannot be inadvertently started while work is being done on the pump.
3. That you know what liquid the pump has been handling and the precautions necessary to safely handle the liquid. Obtain a material safety data sheet (MSDS) for the liquid to be sure these precautions are understood.

Failure to follow above listed precautionary measures may result in serious injury or death.

AMMONIA (Anhydrous Ammonia, NH₃)

Ammonia is a colorless gas or liquid, has a pungent odor, as a gas is lighter than air, is easily liquefied by pressure alone, and is very soluble in water. It boils at -28°F; vapor pressure is 16 PSIG at 0°F, 45 PSIG at 30°F, 93 PSIG at 60°F, and 138 PSIG at 80°F.

DANGER !

Exposure to ammonia causes intense irritation to the surface tissue of the eyes, nose, throat, and lungs. Exposure to high concentrations of ammonia may blind, burn, strangle, or kill.

SAFE PRACTICES

Basic safety practices and equipment should always be used when working with ammonia. Only personnel familiar with ammonia systems should work on these pumps.

A listing of safe practices and equipment are available from many sources, including those listed below. A copy of such a listing and safe practices and equipment should be made available to everyone working where ammonia is used.

Safety Department. The Safety Department of any company using ammonia should have information about the basic safety practices and equipment to use when working with ammonia. The supplier of the ammonia should always have the same information.

ANSI - American National Standard Institute, Inc.

1430 Broadway

New York, New York 10018

Bulletin ANSI-K61.1

CGA - The Compressed Gas Association, Inc.

500 Fifth Avenue

New York, New York 10036

Pamphlet G-2 on Anhydrous Ammonia

IIAR - International Institute of Ammonia Refrigeration

1 Illinois Centre

111 East Wacker Drive

Chicago, Illinois 60601

The above references give specifics on safety practices and equipment. In addition to those, some general precautions include:

WORK CAREFULLY.

DO NOT HURRY.

LOOK AT ANY PRESSURE GAUGES TO DETERMINE CONDITIONS IN THE SYSTEM.

HAVE PLENTY OF WATER AVAILABLE.

VENTING THE PUMP

1. Stop the pump (some maintenance people close the inlet shutoff valve before stopping the pump; but, this is not recommended practice).
2. Close the inlet (suction) side shutoff valve. **A** in figure 4.
3. Close the discharge side shutoff valve. **B** in figure 4.

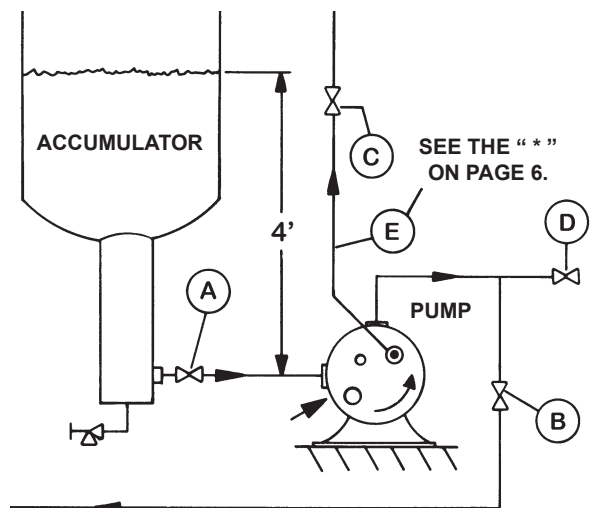

FIGURE 4

Schematic of Piping and Valves For a Liquid Ammonia Recirculating Pump in a Refrigeration System

- Close all other shut off valves in lines connected to the pump. Typical shut off valves include **valve C in line E* in figure 4** from the pump mounted return-to-tank type relief valve to the accumulator or the valve from an in line mounted safety relief valve to the accumulator or the valve in a pressurizing line from the high pressure side of the system to the pump double seal oil reservoir, **line 2 in figure 5**.

* The segment of line (**E in figure 4**) between the return to tank pressure relief valve and the shutoff valve, C, should include a pressure relief valve vented to a safe area.

- Allow ice on pump to melt. This process can be speeded up by running cold water over the pump.

Start the venting process as soon as convenient after the ice has been removed from the pump. This will allow venting the ammonia at the lower pressures of a cold pump rather than at the high vapor pressures in a room temperature pump.

For systems with vent (purge or bleed) valves (e.g. **D figure 4**) go to step 6; for systems without a vent valve, go to step 7.

- A hose should be connected to any vent valve (e.g. **D in figure 4**) in the blocked off portion of the system. The open end of the hose should be placed under water in a tank containing at least 10 times as much water as there is ammonia in the blocked off portion of the system or the end of the hose should be lead to a safe, well ventilated area. After the hose has been attached and the open end properly located under water, then open the vent valve. Check the open end of the hose to make sure the ammonia is venting. After ammonia has stopped venting, continue with step 8.

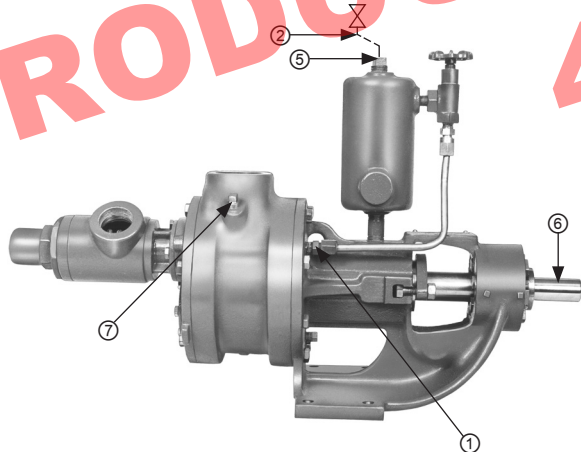

FIGURE 5
Viking K4925

Refrigeration Ammonia Pump with Return-To-Tank Pressure Relief Valve

- If there are no vent valves in the blocked off piping, the Viking Model 4925 ammonia pump should be vented by carefully loosening the fitting (**1 in figure 5**) on the lower end of the tubing that runs from the pump bracket to the double seal oil reservoir.

THERE SHOULD BE A DISTINCT “PSST” SOUND WHEN THE AMMONIA VAPOR LIQUID STARTS TO VENT. LEAVE THE AREA UNTIL THE VENTING IS COMPLETE.

If there is rigid pipe instead of tubing running from the pump bracket to the double seal oil reservoir, the pipe union should be loosened carefully until the “psst” is heard.

If there is no line from the bracket to the reservoir, carefully loosen the pipe plug (drain), **3 in figure 6** towards the bottom of the bracket. This pipe plug is found only on the “K”, “KK”, “LQ” and “LL” 4925 pumps. The small “HL” 4925 does not have one. When working on an “HL” 4925 that has no line between the bracket and double seal oil reservoir, carefully loosen the pipe plug, **4 in figure 6**, in the suction port of the pump.

- Carefully loosen any unions or tubing fittings in any other lines to the pump that have been blocked off by closing the shutoff valves so that venting from these segments of the system can be accomplished. Typical of such lines would be that from the pump mounted return-to-tank relief valve to the accumulator, **E* in figure 4**, or a line from the high pressure side of the system to the double seal oil reservoir, **line 2 in figure 5**.

ALWAYS LISTEN FOR THE “PSST” AT ANY POINT LOOSENED TO PROVIDE VENTING.

- Carefully loosen the fill plug, **5 in Figure 5**, in the top of the double seal oil reservoir.
- After the ammonia has stopped venting, turn the pump shaft, **6 in figure 5**, over for at least 10 complete revolutions. This will make sure that there is no pocket of accumulated ammonia that has not been exposed to a venting point.
- Carefully loosen the plugs, **4 in figure 6 and 7 in figure 5**, in the suction and discharge ports of the pump. If ammonia continues to vent, wait until the venting stops. When venting from all the loosened connections stops, then complete the loosening of the fittings and complete the removal of the plugs.

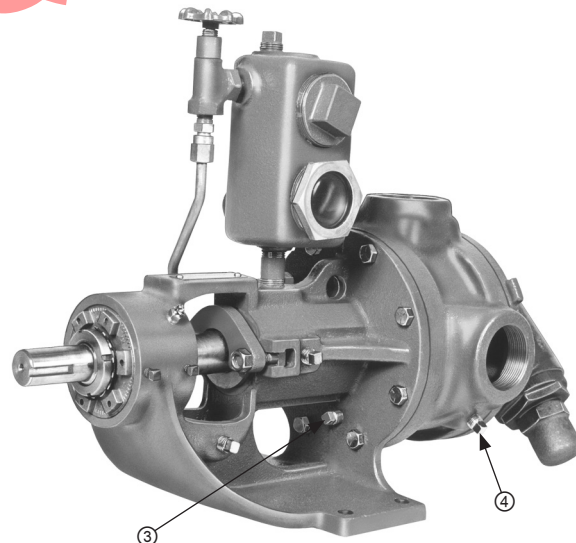

FIGURE 6
Viking K4925

Refrigeration Ammonia Pump with Internal Pressure Relief Valve

- When all venting has stopped, continue with removing the pump from the system or disassembly of the pump in place.

DISASSEMBLY

DANGER !

Before opening any Viking pump liquid chamber (pumping chamber, reservoir, etc.) Be sure:

1. That any pressure in the chamber has been completely vented through the suction or discharge lines or other appropriate openings or connections. (See detailed procedure for venting the pumps, pages 5 and 6).
2. That the driving means (motor, turbine, engine, etc.) has been "locked out" or made otherwise non-operational so that it cannot be inadvertently started while work is being done on the pump.
3. That you know what liquid the pump has been handling and the precautions necessary to safely handle the liquid. Obtain a material safety data sheet (MSDS) for the liquid to be sure these precautions are understood.

Failure to follow above listed precautionary measures may result in serious injury or death.

NOTE: BE SURE TO READ PAGES 4 THRU 7 PRIOR TO PUMP DISASSEMBLY.

1. Mark head and casing before disassembly to ensure proper reassembly. The idler pin, which is offset in pump head, must be positioned toward and equal distance between port connections to allow for proper flow of liquid through pump.

Remove head from pump.

Do not allow idler to fall from idler pin. Tilt top of head back when removing to prevent this. Avoid damaging head gasket. If pump is furnished with pressure relief valve, it need not be removed from head or disassembled at this point. Refer to Pressure Relief Valve Instructions, page 12.

2. Remove idler and bushing assembly from the idler pin.
3. Bend up the tang on the lockwasher and use a spanner wrench to remove the lockwasher and locknut. **NOTE:** A piece of brass or wood inserted through the port opening and between the rotor teeth will keep the shaft from turning.

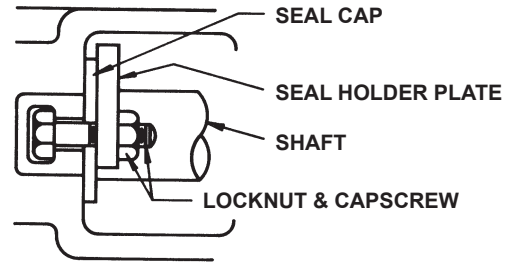

FIGURE 7

4. Loosen the two locknuts and remove the seal holder plate. For parts identification, see figure 7.
5. Drive the shaft forward approximately 1/2" and remove the pair of half round rings ("K" - "LL" size) under the inner bearing spacer collar or a snap ring ("HL" size) at the end of the inner bearing spacer collar, see figure 8.

NOTE: The snap ring ("HL" size) or half round rings ("K" - "LL" size) must be removed before the rotor and shaft can be removed from the pump. These rings will not pass through the mechanical seal and bracket bushing.

6. Carefully remove the rotor and shaft. As the shaft is being removed decreasing shaft diameters tend to allow the shaft to drop onto the bracket bushing. To avoid damaging the bracket bushing, support the rotor and do not allow either end of the shaft to tilt downward.

NOTE: Considerable force may be required to remove the rotor and shaft from the pump. Be careful as not to damage seal parts as the rotor and shaft is removed. Some of the seal parts may fall off when the rotor and shaft are removed. Place them to the side to be put with other mechanical seal parts when they are removed.

7. Loosen the four setscrews over the outer and inner end caps. Remove both end caps, ball bearing, and bearing spacer collars. See figure 8.

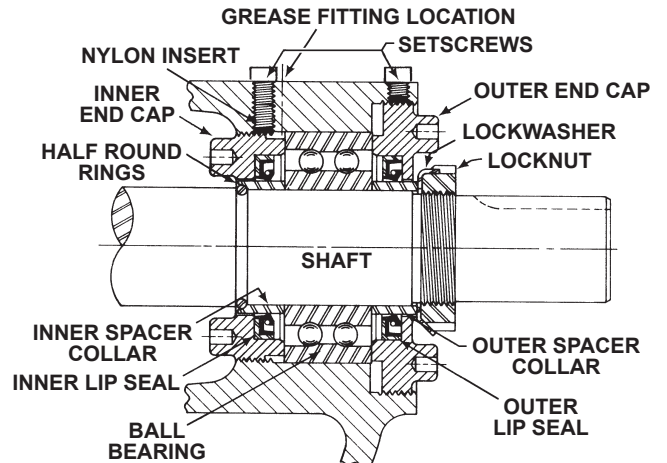

FIGURE 8

NOTE: The inner end cap can be removed through the side opening in the bracket.

For Viking old series 924 Heavy Duty Refrigeration Ammonia Pumps go to page 14 for bearing housing disassembly instructions.

8. The seal seats and rotary members of the seal may be removed from the side opening of the bracket; see step 11 for removal of the double mechanical seal.
9. Clean all parts thoroughly and examine for wear or damage. Check lip seals, ball bearing, bushings, and mechanical seal and replace as necessary. Check all other parts for nicks, burrs, excessive wear, and replace if necessary.

NOTE: Be sure that the shaft is free from burrs and foreign particles that might damage the bracket bushing. Scratches on the shaft in the seal area will provide leakage paths under the mechanical seal.
10. Check casing for wear or damage while mounted to the bracket.

DOUBLE MECHANICAL SEAL

See figure 11. The mechanical seal consists of five basic parts. They are: inner and outer seal seats with O-ring gaskets; inner and outer rotary members; and spring. When pump is running, the seal cap and inner and outer seal seats with O-ring gaskets remain stationary in the bracket seal housing bore; the inner and outer rotary members turn with the shaft.

11. The pump has now been disabled to the point where the double mechanical seal may be removed from the seal housing bore of the bracket.

NOTE: Pay particular attention to the location, arrangement and construction of the seal parts as it will help considerably when the pump is reassembled.

12. Remove the seal cap if it was not removed in step 6. A light tap may be necessary to loosen it.
13. The O-ring gaskets of the seal seats may have become slightly sealed against the side of the housing and require extra effort. If this happens, apply light oil in the seal housing bore in front of the seats so they will slide freely.
14. After removing the outer seal seat, the outer rotary member, the spring, and the inner rotary member can be removed.
15. Remove the inner seal seat and gasket by bending the ends of two lengths of wire and then by inserting the bent end in the slots in the bushing and pulling the seal seat through the housing from the shaft end. If removal is difficult, an arbor press may be used to push the bracket bushing, seal seat, and gasket out of the bore from the rotor end. Another coating of light oil may be helpful to ease the seal seat out of the housing.

Another way of removing the inner seal seat is to drive it out while inserting a screwdriver through the bracket bushing from the casing end so it hits the seal seat at the notches in the bracket bushing. Be careful and do not damage the bracket bushing when removing the inner seal seat in this manner.

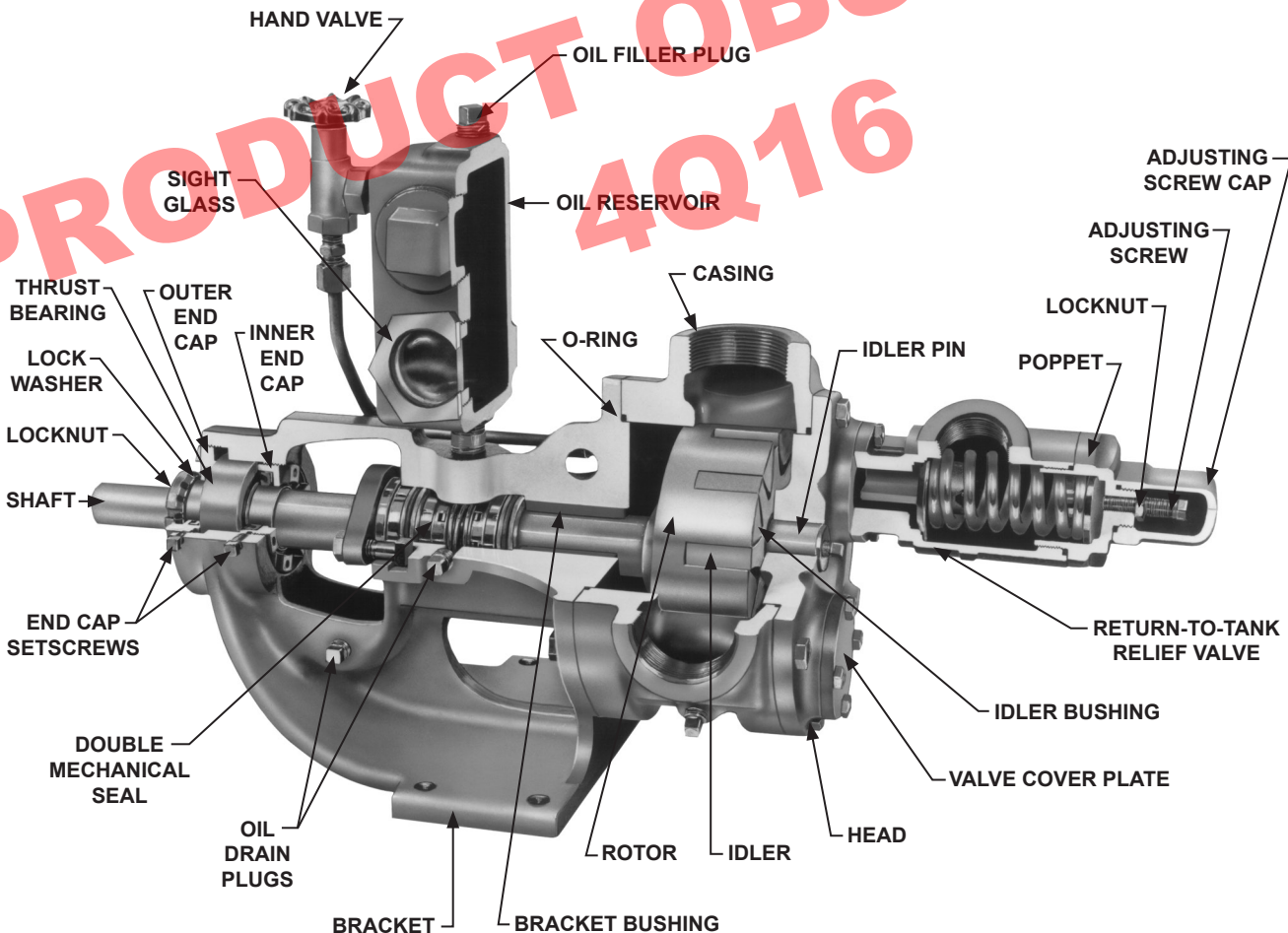

FIGURE 9

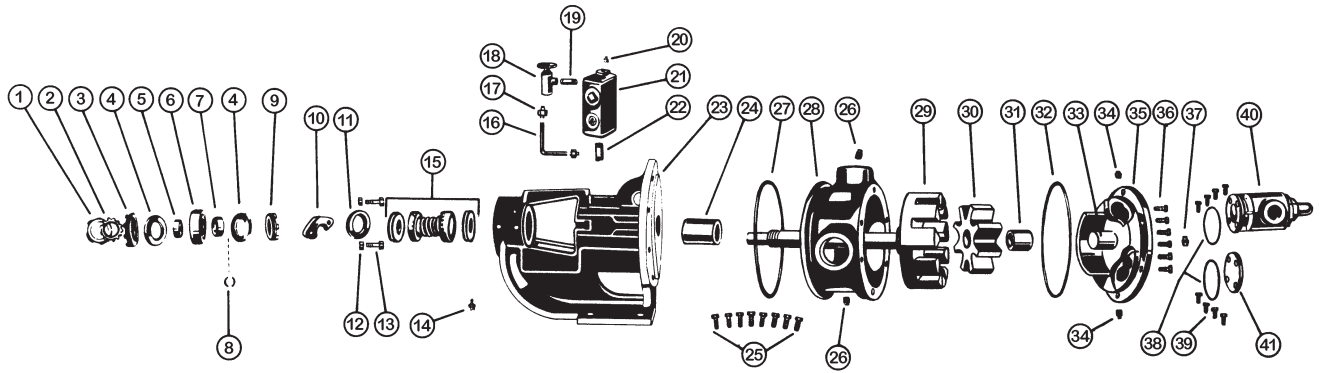

FIGURE 10
Exploded View Series 4925

ITEM	NAME OF PART	ITEM	NAME OF PART	ITEM	NAME OF PART
1	Locknut	15	Double Mechanical Seal	29	Rotor & Shaft
2	Lockwasher	16	Reservoir Tubing	30	Idler & Bushing
3	End Cap (Outer)	17	Tube Fittings (2 Req'd)	31	Idler Bushing
4	Lip Seal, Bearing Housing (2 Req'd)	18	Hand Valve	32	O-Ring Gasket, Head
5	Bearing Spacer Collar (Outer)	19	Nipple	33	Idler Pin, Lube
6	Ball Bearing	20	Pipe Plug	34	Check Valve (2 Req'd)
7	Bearing Spacer Collar (Inner)	21	Reservoir with Sight Glass & Plug	35	Head Idler Pin
8	Ring, Half Round (2 Req'd)	22	Nipple	36	Capscrew for Head (6 Req'd)
9	End Cap (Inner)	23	Bracket and Bushing	37	Pipe Plug
10	Seal Holder Plate	24	Bracket Bushing	38	O-Ring Valve Gasket (2 Req'd)
11	Seal Cap	25	Capscrew for Bracket (8 Req'd)	39	Capscrew for Valve & Cover Plate (8 Req'd)
12	Nut for Seal Holder Plate (2 Req'd)	26	Pipe Plug (4 Req'd)	40	Return-To-Tank Relief Valve & Cover Plate
13	Capscrew for Seal Holder Plate (2 Req'd)	27	O-Ring Gasket Bracket	41	Cover Plate, Relief Valve
14	Grease Fitting	28	Casing		

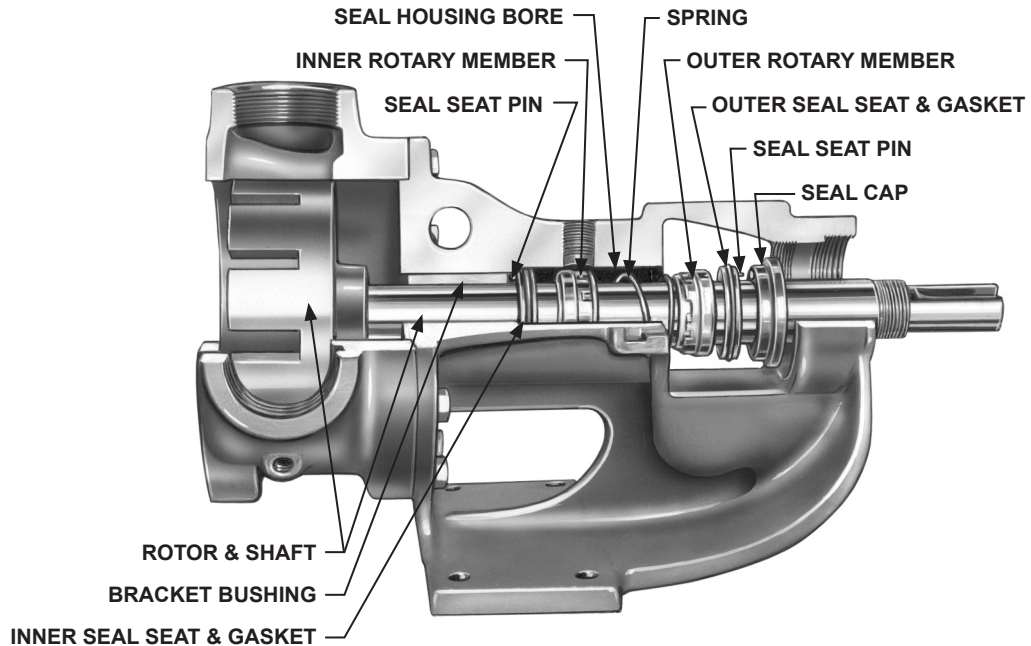

FIGURE 11

ASSEMBLY

1. Installing a new seal: The seal is simple to install and good performance will result if care is taken in installation, see figure 11, page 9 for parts identification.

Seals made by different manufacturers are used in these pumps and are used interchangeably though they may look different and have a different spring.

After all parts have been examined and cleaned or replaced as necessary, the first step in reassembling the pump is installation of the inner seal seat.

Good performance will result if care is taken during installation.

NOTE: Never touch mechanical seal faces with anything except clean hands, cardboard, or clean cloth. Minute particles can scratch the seal faces and cause leakage.

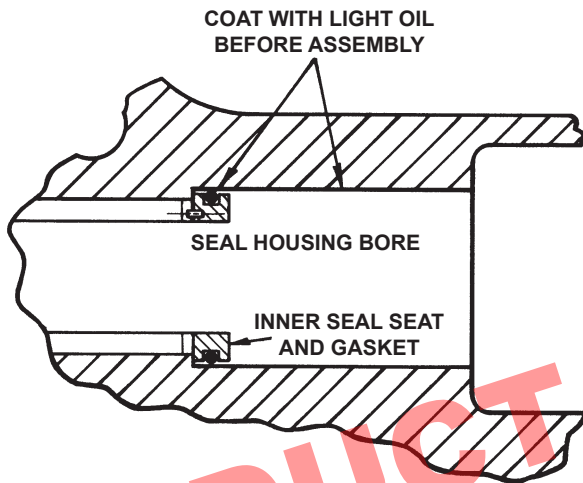

FIGURE 12

2. Clean the bracket seal housing bore, making sure it is free of dirt and grit.
3. Coat the outside of the inner seal seat and O-ring gasket and also the inside diameter of the seal housing bore with light Refrigeration Oil (not grease), see figure 12. Press the inner seal seat with O-ring gasket into place in the seal housing bore with your fingers or by putting a piece of cardboard over the face of the seal seat and pressing with a block of wood or squared off piece of pipe. Remove the cardboard. Figure 13 shows how the inner seal seat pin fits into either of the slots in the end of the bracket bushing. Be sure the pin engages one of these slots in the bushing when you have finished pushing the seal seat into the seal housing bore. Check by looking through the bracket bushing from the casing end.



FIGURE 13

4. Clean and coat the pump shaft with light Refrigeration Oil. Check to be sure no scratches have been cut into the shaft in the seal area.

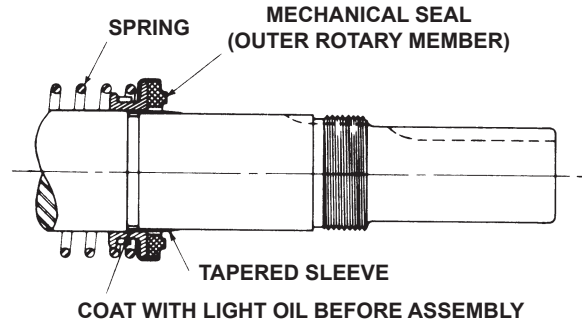

FIGURE 14

5. After replacing the casing on the bracket, place the rotor and shaft into the casing.

NOTE: If the casing is removed from the bracket, be sure the bracket O-ring is in place before placing casing on bracket.

6. Place the O-ring or head gasket on the head.
7. Coat idler pin with light Refrigeration Oil and place idler and bushing on idler pin in head. If replacing carbon graphite bushing, refer to Installation of Carbon Graphite Bushings, page 12. Install head and idler assembly onto the pump. Make sure the idler pin, which is offset in the pump head, is positioned toward and equal distance between port connections to allow for proper flow of liquid through the pump. Tighten the head capscrews evenly.
8. Place the tapered installation sleeve (furnished with replacement seals K-LL size) on the shaft as shown in figure 14.
9. Clean and oil the I.D. of the inner rotary member, place on shaft and slide over the tapered installation sleeve into position against the inner seal seat. Push against the rubber tail section of the bellows with a sleeve or smooth piece of pipe having an inside diameter no more than $\frac{1}{32}$ inch larger than the shaft diameter and a wall thickness of at least $\frac{1}{8}$ inch. Be sure to install correct end against seal seat, see figure 11, page 9. Be sure carbon face does not fall out of the rotary member.
10. Slide the spring along the shaft and make sure it seats properly over the inner rotary member. It may be helpful to stand pump on end to facilitate centering the spring.
11. Coat the outer seal seat and O-ring gasket with light Refrigeration Oil. Spread a thin film of grease on the seal cap. Place the outer seal seat in position on the seal cap. Make sure the pin in the seal seat engages the hole in the seal cap. The film of grease will hold these two parts together; set them aside temporarily.
12. Coat the inside diameter of the outer rotary member with light Refrigeration Oil. Place it on the shaft and slide over the tapered installation sleeve until it engages the spring. Be sure to install the correct end towards the spring, see figure 11, page 9.
13. Quickly install the outer seal seat and cap prepared in step 11 over the shaft and press down against the outer rotary member until the seal cap hits the end of the bracket. This compresses the spring and positions the outer rotary member. Do not release the seal cap.

14. Still holding the seal cap against the end of the bracket, place half-moon shaped seal holder plate in position and tighten the two locknuts uniformly. This holds the seal cap in position and ensures proper positioning of seal.

NOTE: Do not permit either the inner or outer rotary member to remain on the shaft in any position other than their final position for more than 30 seconds since the rubber bellows of the rotary members have a tendency to stick to the shaft. If the bellows are not in correct position, the rotary member will be improperly seated.

15. Remove tapered sleeve.
16. Place the inner bearing spacer collar on the shaft as far as it will go.

NOTE: First replace the snap ring ("HL" size) or half round rings ("K" - "LL" size), **see figure 15.**

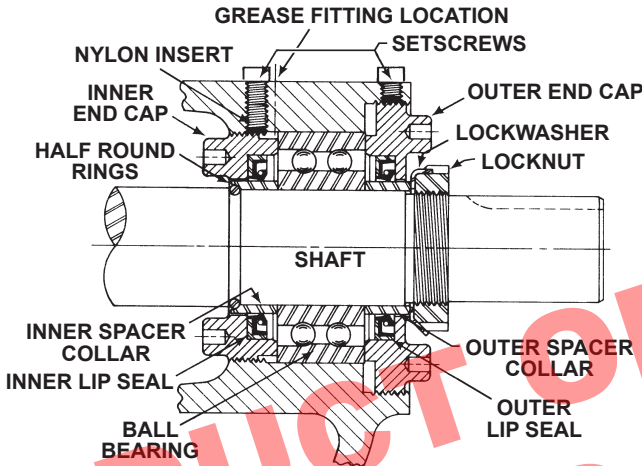

FIGURE 15

17. Press the lip seal (lip toward end of shaft) into the inner end cap, and insert the end cap through the shaft end of bracket. With two fingers turn it clockwise (looking at end of shaft) until it engages the threads. The spanner holes in the inner end cap must be toward the rotor. Turn the end cap with a spanner wrench until it projects slightly into the opening on the side of the bracket.

NOTE: The end cap must not be turned so far that the lip of the seal drops off the end of the spacer collar on the shaft or the end cap becomes disengaged with the threads, **see figure 15.**

18. Pack the ball bearing with multi-purpose, polyurea, NLGI #2 grease and place on the shaft and push or gently drive into place in the bracket.
19. Install the lip seal (lip toward end of shaft) and bearing spacer in the outer end cap and turn the end cap in the bracket until tight against the bearing, **see figure 15.**

*For Viking Old Series 924 Heavy-Duty Refrigeration Pumps see page 14 for bearing housing disassembly, assembly, and adjusting instructions.

20. Put lockwasher and locknut on shaft. Insert length of hardwood or brass through port opening between rotor teeth to keep shaft from turning. Tighten locknut to 50-70 ft.- lbs. torque (HL) or 100-130 ft. - lbs. torque (K - LL).

Bend one tang of lockwasher into a slot of the locknut. If tang does not line up with a slot, tighten locknut until it does. Failure to tighten locknut or engage lockwasher tang could result in early bearing failure and cause damage to rest of pump.

Remove length of hardwood or brass from port opening.

21. Adjust the pump end clearance as indicated in **THRUST BEARING ADJUSTMENT**, below.
22. Insert the pipe plug (drain) into the bracket. Close the hand valve and fill the reservoir to within 1½ inches of the top with light Refrigeration Oil. It is recommended that the oil be drained and the reservoir be refilled after the first 200 hours of operation and then after every 1000 hours.

NOTE: Re-open the hand valve before the pump is put into operation. The double mechanical seal will not function properly if it is exposed to ammonia pressure with this valve closed.

THRUST BEARING ADJUSTMENT

1. Loosen the square head setscrews over the outer and inner end caps (two for the HL size, four for the K thru LL size pumps).
2. Turn the inner end cap clockwise (viewed from shaft end) until it projects slightly from the bracket exposing approximately three threads.
3. Turn the outer end cap clockwise until the rotor is tight against the head and the rotor shaft cannot be turned.
4. Make a reference mark on the bracket end, opposite a notch on the outer end cap. Back off the outer end cap the required number of notches shown in the table, **see figure 16.**
5. Tighten the inner end cap with a spanner wrench. Tap the spanner wrench lightly but **DO NOT OVER TIGHTEN**, as it will only damage the threads.
6. Tighten all the square head setscrews that hold the inner and outer end caps to prevent their turning in the bracket.
7. The rotor and shaft should turn smoothly for one complete revolution. If the rotor and shaft doesn't turn smoothly, go back and repeat the Thrust Bearing Adjustment steps 1 thru 7.

PUMP SIZE	Turn Outer End Cap C.C.W.	
	No. of Notches	or Length on O.D., Inches
HL	3	½"
K - LL	5	2½/32"

FIGURE 16

INSTALLATION OF CARBON GRAPHITE BUSHINGS

When installing carbon graphite bushings, extreme care must be taken to prevent breaking. Carbon graphite is a brittle material and easily cracked. If cracked, the bushing will quickly disintegrate. Using a lubricant and adding a chamfer on the bushing and the mating part will help in installation. The additional precautions listed below must be followed for proper installation.

1. A press must be used for installation.
2. Be certain bushing is started straight.
3. Do not stop pressing operation until bushing is in proper position. Starting and stopping will result in a cracked bushing.
4. Check bushing for cracks after installation.

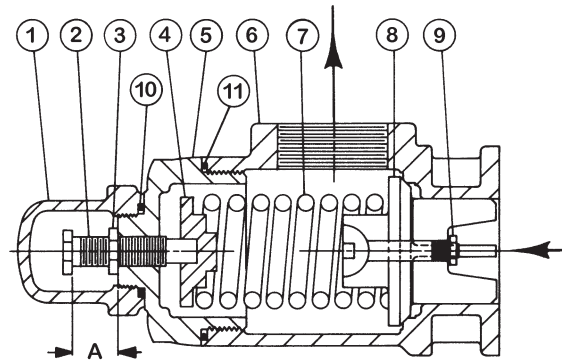

FIGURE 18

PRESSURE RELIEF VALVE INSTRUCTIONS

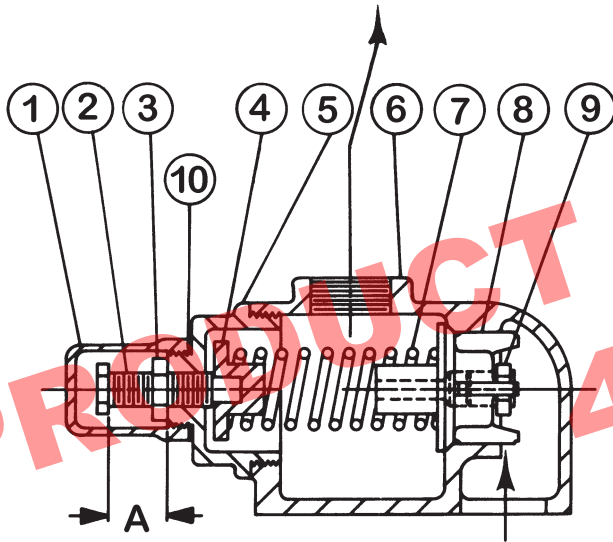

FIGURE 17

VALVE - LIST OF PARTS	
1. Valve Cap	7. Valve Spring
2. Adjusting Screw	8. Poppet
3. Lock Nut	9. Pressure Relief Plug
4. Spring Guide	10. Cap Gasket
5. Bonnet	11. Bonnet Gasket
6. Valve Body	

VALVE - LIST OF PARTS	
1. Valve Cap	6. Valve Body
2. Adjusting Screw	7. Valve Spring
3. Lock Nut	8. Poppet
4. Spring Guide	9. Pressure Relief Plug
5. Bonnet	10. Cap Gasket

DANGER !

Before opening any Viking pump liquid chamber (pumping chamber, reservoir, etc.) Be sure:

1. That any pressure in the chamber has been completely vented through the suction or discharge lines or other appropriate openings or connections. (See detailed procedure for venting the pumps, pages 5 and 6).
2. That the driving means (motor, turbine, engine, etc.) has been "locked out" or made otherwise non-operational so that it cannot be inadvertently started while work is being done on the pump.
3. That you know what liquid the pump has been handling and the precautions necessary to safely handle the liquid. Obtain a material safety data sheet (MSDS) for the liquid to be sure these precautions are understood.

Failure to follow above listed precautionary measures may result in serious injury or death.

DISASSEMBLY

NOTE: Mark the valve and head, or casing, to be sure they are reassembled in the same relative position.

1. Remove end cap. Make sure the bonnet is not loosened as valve cap is removed.
2. Measure and record the length of extension of the adjusting screw. Refer to "A" on Figure 17 and 18.
3. Loosen the lock nut and back out adjusting screw until spring pressure is released.
4. Remove the bonnet, spring guide, spring, and poppet from valve body. Clean and inspect all parts for wear or damage and replace as necessary.

ASSEMBLY

Reverse the procedure outlined under disassembly. If valve is removed for repairs, be sure to replace in same position.

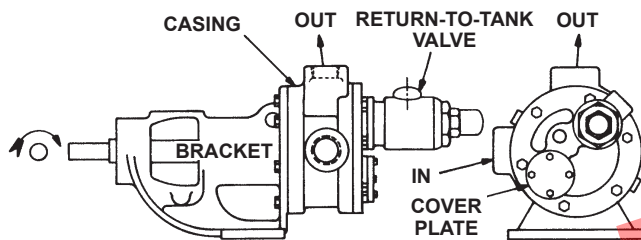

FIGURE 19

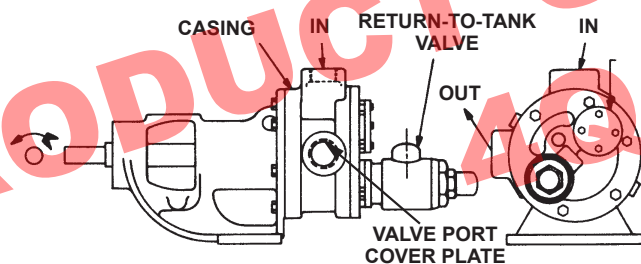

FIGURE 20

Figure 19 shows the standard pump rotation (clockwise). When viewing the shaft end, the inlet port is on the right and the outlet on the top.

If the pump rotation is reversed as shown on figure 20 to give counterclockwise rotation when viewing the shaft end, the inlet port is on the top and the outlet port on the right.

On "HL" size pumps equipped with Return-To-Tank pressure valves, (see figure 17) the cap should point towards the suction side of pump.

On "K" - "LL" size pumps equipped with return-to-tank pressure relief valves, (see figure 18) the valve must always be mounted on the valve port nearest the pump discharge port, see figure 21. Valve port nearest the pump inlet port must be covered with the valve cover plate.

PRESSURE ADJUSTMENT

If the pressure setting of the valve is to be changed from that which the factory has set, the following instructions should be carefully followed:

DANGER !

Before opening any Viking pump liquid chamber (pumping chamber, reservoir, etc.) Be sure:

1. That any pressure in the chamber has been completely vented through the suction or discharge lines or other appropriate openings or connections. (See detailed procedure for venting the pumps, pages 5 and 6).
2. That the driving means (motor, turbine, engine, etc.) has been "locked out" or made otherwise non-operational so that it cannot be inadvertently started while work is being done on the pump.
3. That you know what liquid the pump has been handling and the precautions necessary to safely handle the liquid. Obtain a material safety data sheet (MSDS) for the liquid to be sure these precautions are understood.

Failure to follow above listed precautionary measures may result in serious injury or death.

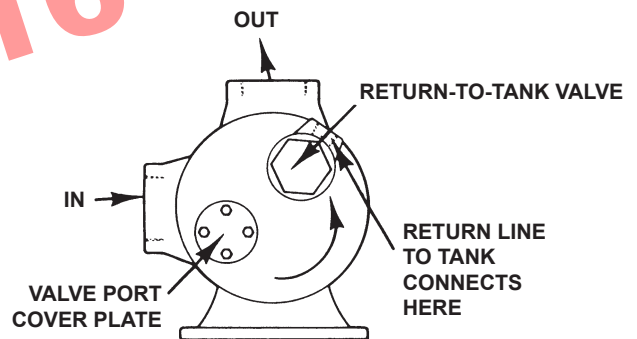

FIGURE 21

1. Carefully remove valve cap which covers the adjusting screw. Make sure the bonnet is not loosened as valve cap is removed.
2. Loosen the locknut, which locks the adjusting screw so pressure setting will not change during operation of pump.
3. Install a pressure gauge in discharge line for actual adjusting operation.
4. Turn adjusting screw in to increase pressure and out to decrease pressure.
5. With discharge line closed at point beyond pressure gauge, gauge will show maximum pressure valve will allow while pump is in operation.

The Viking Over-Pressure Relief Valve is strictly an over-pressure relief valve; it is not a pressure regulating valve.

When ordering parts for relief valve, always be sure to give Model and Serial Number of the pump as it appears on the nameplate (secured to the pump) and the name of the part wanted. When ordering springs, be sure to give the pressure setting desired.

VIKING OLD SERIES 924 HEAVY-DUTY REFRIGERATION AMMONIA PUMPS THRUST BEARING DISASSEMBLY, ASSEMBLY, & ADJUSTMENT

DISASSEMBLY

1. Loosen radial set screws in the outer ring of the bearing housing, and remove the bearing housing end cap, lip seal, and bearing spacer collar. Use a spanner wrench to remove the end cap.
2. Remove the double row ball bearing. The bearing should be washed thoroughly and examined. If there is any evidence of wear or damage, a new bearing should be used.
3. Examine the lip seal in the bearing housing and end cap. These lip seals are important to the assembly and should be replaced if not in first class condition. They are a grease seal for the ball bearing and also act as a shield to keep dirt and other abrasive particles from entering the bearing. When installing new lip seals, be sure they are assembled with the lips facing toward the shaft end. See figure 22.

Return to page 8, step 8, for further disassembly.

ASSEMBLY

1. Place the inner bearing spacer collar on the shaft as far as it will go.
NOTE: First replace the snap ring or keeper rings if furnished in your pump. See figure 22.
2. Install the bearing housing with inner lip seal into the bracket.
NOTE: If bearing housing has not been disassembled or has been pre-assembled skip items 3 and 4.
3. Pack the ball bearing with grease, place on the shaft and push or gently drive into place in the housing.
4. Turn the bearing housing end cap (with lip seal and bearing collar inside) into the bearing housing until it is tight against the bearing. Lock in place by tightening the radial set screws in the outside diameter of the bearing housing.
5. Turn the bearing housing assembly clockwise until pump shaft can no longer be turned by hand. The rotor is now forced against the head.
6. Install the lockwasher and locknut on the shaft, tighten lock nut and bend down tang of the lockwasher into slot of locknut.
NOTE: A piece of brass or wood inserted through the port opening between the rotor teeth will keep the shaft from turning.

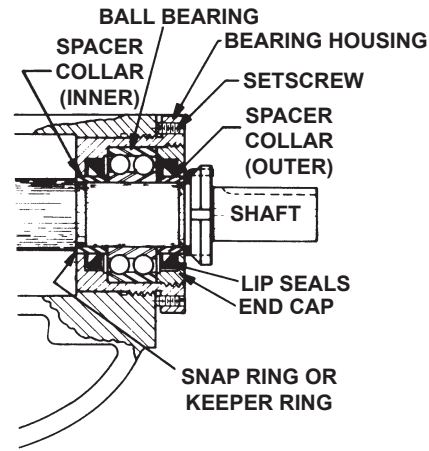

FIGURE 22

THRUST BEARING ADJUSTMENT

1. Loosen two axial set screws in the outer face of the bearing housing and turn the thrust bearing assembly clockwise until it can no longer be turned by hand. Back off counterclockwise until the rotor and shaft can be turned by hand with a slight noticeable drag.
2. For standard end clearance, back off the thrust bearing assembly the required number of notches or an equivalent length measured on the outside of the bearing housing. See the following table.

PUMP SIZE	Turn Outer End Cap C.C.W.	
	No. of Notches*	or Length on O.D., Inches
HL	2	1/2"
K - LL	4	1"

3. Tighten the two axial set screws in the outboard face of the bearing housing with equal force against the bracket. Your pump is now set with standard end clearance and locked.
NOTE: Be sure the shaft can rotate freely. If not, back off additional notches and check again.
4. Each additional notch (or each 1/4" on the outside diameter of the bearing housing) is equivalent to an extra end clearance of .002" on HL size pumps; and .0015" on K, KK, LQ and LL size pumps.
5. Insert the pipe plug (drain) into the bracket. Close the hand valve and fill oil reservoir within 1 1/2" of the top with light Refrigeration Oil. It is recommended that the oil be drained and the reservoir be refilled after the first 100 hours of operation and then after every 1000 hours.
NOTE: Re-open the hand valve before the pump is put into operation. The double mechanical seal will not function properly if it is exposed to ammonia pressure with the valve closed.
6. Return to **Installation of Carbon Graphite Bushings, page 12**, and continue on.

TROUBLESHOOTING

A Viking pump that is properly installed and maintained will give long satisfactory performance.

If trouble does develop, one of the first steps toward finding the difficulty is to install a vacuum gauge in the suction line and a pressure gauge in the discharge line. Readings on these gauges often give a clue on where to start looking for trouble.

DANGER !

Before opening any Viking pump liquid chamber (pumping chamber, reservoir, etc.) Be sure:

- 1. That any pressure in the chamber has been completely vented through the suction or discharge lines or other appropriate openings or connections. (See detailed procedure for venting the pumps, pages 5 and 6).**
- 2. That the driving means (motor, turbine, engine, etc.) has been "locked out" or made otherwise non-operational so that it cannot be inadvertently started while work is being done on the pump.**
- 3. That you know what liquid the pump has been handling and the precautions necessary to safely handle the liquid. Obtain a material safety data sheet (MSDS) for the liquid to be sure these precautions are understood.**

Failure to follow above listed precautionary measures may result in serious injury or death.

1. PUMP WILL NOT START TO ROTATE.

- A.** Motor not hooked up or hooked up correctly - check wiring.
- B.** Something has gotten into pump and has jammed rotating parts - remove head and take out obstruction.
- C.** End clearance has been set too close - adjust end clearance.
- D.** Drive equipment jammed - remove obstruction.

2. PUMP FAILS TO PUMP.

- A.** Suction line valve not open - open valve.
- B.** Suction strainer is plugged - clean strainer.
- C.** Pump vapor bound - vent discharge lines.

- D.** Relief valve bypassing - remove obstruction or open valve. Weld bead or other foreign material under poppet - disassemble valve and remove foreign material. Valve setting too low for differential pressure required - increase setting or get heavier spring.
- E.** Pump rotating wrong way - change direction of motor rotation or change piping.
- F.** No liquid in accumulator - check controls.
- G.** Drive equipment broken - repair or replace.

3. PUMP IS NOISY.

- A.** Cavitation (liquid vaporizing on suction side of pump) - increase head of liquid on pump; reduce line loss in suction piping; insulate suction line; reduce pump speed.
- B.** Pump is starved due to no liquid in the accumulator - adjust floats or time cycle.
- C.** Relief valve chattering - increase pressure setting of relief valve.
- D.** Binding - check alignment of unit; check for pipe strain.
- E.** Drive equipment worn or damaged - repair or replace.

4. LOW CAPACITY

- A.** Motor running at wrong speed - check wiring.
- B.** Speed too slow - change drive or get motor with faster rated speed.
- C.** Too much end clearance - adjust end clearance.
- D.** Internal wear - replace worn parts.
- E.** Pump too small - use a larger pump or two small ones.
- F.** Suction line too small - reduce length or increase size.
- G.** Relief valve opening - increase pressure setting.
- H.** Bypass line valve open - adjust valve.

5. RAPID WEAR.

- A.** Dirt in the system - install suction line strainer temporarily until system is clean.
- B.** Cavitation (liquid vaporizing on suction side of pump) - increase head of liquid on pump; reduce line loss in suction piping; insulate suction line; reduce pump speed.
- C.** Pump misaligned or distorted - check alignment of unit; check for pipe strain.
- D.** Running too fast - change drive or use larger pump that could run slower.
- E.** Pump runs dry part of time - check level controls to be sure there is always liquid in the pump.

6. RELIEF VALVE DOES NOT FUNCTION

- A.** Installed incorrectly - return-to-tank type relief valve should be mounted on the head opening toward the discharge side of pump. Internal type relief valve should be mounted so the cap points toward suction port of pump.

- B. Setting too high - reduce setting or get lighter spring.
- C. Valve poppet binding - remove poppet, check for burrs or foreign material.
- D. Shut-off valve in relief valve return line closed - open valve (would apply only to pumps with return-to-tank type relief valves).

7. MECHANICAL SEAL LEAK.

- A. Normal wear - replace seal.
- B. Improper installation - review installation procedure outlined on pages 10 and 11.
- C. Abrasive material in liquid - if abrasive material on ammonia side, use traps or strainer to clean system; if on oil side, change oil more frequently and use clean oil.
- D. Pump operating at very low temperature causing oil to become heavy - use lighter oil or use immersion heater to heat oil.

AMMONIA

Ammonia (Anhydrous Ammonia, NH3)

Ammonia is a colorless gas or liquid, has a pungent odor, as a gas is lighter than air, is easily liquefied by pressure alone, and is very soluble in water or alcohol.

Ammonia is one of the best known and widely used refrigerants in use today in ice plants, food lockers, cold storage warehouses, and other industrial cooling processes. Ammonia has a higher refrigeration effect, per unit of liquid volume, than any other type of commonly used refrigerant; other advantages are low initial cost and low pipe friction losses.

Thus the temperature around the container can be controlled by the pressure maintained in the container. **Table 2** shows the ammonia vapor pressure for various temperatures.

* The same phenomena takes place to lower the boiling point of water when the pressure is lowered. This explains the low boiling point of water on a mountain top.

The saturation properties of ammonia make it desirable for use as a refrigerant. The temperatures necessary for freezing and keeping food products can be quite easily achieved with pressures or vacuums readily developed by available equipment.

SATURATED VAPOR PRESSURE			
Temp. °F.	"Hg. Vacuum	PSI Gage	PSI Absolute
-100	27.4		1.24
180	24.3		2.74
-60	18.6		5.55
-50	14.3		7.67
-40	8.7		10.4
-30	1.6		13.9
-28	0	0	14.7
-20		3.6	18.3
-10		9.0	23.7
0		15.7	30.4
10		23.8	38.5
20		33.5	48.2
30		45.0	59.7
40		58.6	73.3
50		74.5	89.2
60		92.9	108
80		138	153
100		197	212

PHYSICAL PROPERTIES	
Boiling point (atmospheric pressure)	-28°F.
Freezing point (atmospheric pressure)	-107.9°F.
Viscosity at -28°F.	0.27 centipose
Specific Gravity at -28°F.	0.68
Liquid Density at -28°F.	42.6 lbs./ft ³
Liquid Density at -28°F.	5.7 lbs./gal.
* Latent heat of vaporization at -28°F.	589 BTU/lb.

TABLE 1

*** (Number of Btu's to change one pound liquid ammonia from liquid to gas)**

Ammonia, like LP-Gas and other vapor high pressure liquids, has to be kept in a closed container to keep it from boiling away. For a given temperature, the pressure built up within the container is equal to the vapor pressure or saturation pressure. Conversely for any given pressure, there is a temperature at which the liquid and vapor are in equilibrium (saturation temperature); **see table 2**. If the pressure in the container is held constant and the vapor is withdrawn, the ammonia will vaporize (boil). As it boils, it picks up heat from the area around the container since over 500 Btu's are necessary to change one pound of ammonia from liquid to vapor. If the pressure over the ammonia is reduced, the boiling temperature will be reduced and the boiling temperature will be lowered.

AMMONIA VAPOR PRESSURE TABLE 2

Grades of Ammonia Available - commercial grade 99.5%, refrigeration grade 99.95%.

Explosive Limit in Air, by Volume - 15 to 28%.

Corrosion - Ammonia will not attack iron or steel even in the presence of moisture; it will attack copper, brass, bronze, and zinc in the presence of moisture.

Toxicity - Concentrations of ammonia in air as low as 53 parts per million can be detected by the sharp penetrating odor.

Exposure to ammonia causes intense irritation to the surface tissues of the eyes, nose, throat, and lungs. Exposure to high concentration of ammonia may blind, burn, strangle, or kill.

The effect of ammonia on the skin is that of a caustic burn, varying in severity with the concentration of ammonia and the length of time exposed. Changes in respiratory and heart action produced are reflex actions resulting from the irritation of the respiratory tract.

For information on the safe handling of ammonia, **see SAFE PRACTICES, page 5**.

Figure 23 is a schematic of a simple Vapor Ammonia Refrigeration System with the major pieces of equipment named and numbered. Each piece of equipment is described briefly and its function in the system discussed in the following paragraphs. To illustrate temperatures and pressures that would exist in an actual illustration, there is given with the discussion of each piece of equipment the actual temperature and pressure for a system operating with a condenser temperature of 86°F and an evaporator temperature of 5°F.

1. **RECEIVER** - A storage tank for ammonia at ambient temperatures. The receiver "receives" the liquid ammonia as it comes from the condenser. The pressure in the receiver will correspond to the vapor pressure of the ammonia at the temperature of the cooling medium used in the condenser. In this case with an 86°F condenser temperature, the ammonia pressure would be 154 PSI (the saturation pressure corresponding to a temperature of 86°F).
2. **EXPANSION VALVE** - A throttling valve that controls the amount of liquid that flows into the evaporator. It can be controlled manually or by thermostats located in the evaporator. The temperature and pressure of the liquid on the inlet side of the expansion valve is the same as that in the receiver (86°F and 154 PSIG); the pressure on the outlet side of the expansion valve is that maintained in the evaporator by the compressor; (the compressor would have to pull down and hold the pressure in the evaporator at 19 PSIG to maintain the evaporator temperature at 5°F; this is the saturation temperature corresponding to 19 PSIG).
3. **EVAPORATOR** - The evaporator is the main purpose for the existence of the refrigeration system. It is through the evaporator that heat is picked up by the ammonia. The temperature in the evaporator area will be "pulled down" to the saturation temperature of ammonia at the pressure maintained by the compressor. The ammonia enters as a liquid at the temperature in the receiver; it leaves as a vapor (gas) at the saturation temperature. (For the system being considered, the pressure in the evaporator would have to be maintained at 19 PSIG. This is the pressure corresponding to a saturation temperature of 5°F).

4. **COMPRESSOR** - The compressor pulls the ammonia vapors from the evaporator. The pressure or vacuum pulled in the evaporator by the compressor will determine the pressure at which the evaporator works. The compressor compresses the ammonia gas to the pressure corresponding to the saturation pressure of the ammonia at the temperature maintained in the condenser. The compressed ammonia gas as it leaves the compressor is hot and is in a super heated vapor state. (The vapor pulled into the compressor is at 5°F, the vapor as it leaves is at a temperature of approximately 210°F and a pressure of 154 PSIG. The pressure of 154 PSIG is the saturation pressure of the ammonia at the 86°F condenser temperature).
5. **CONDENSER** - The condenser cages the super heated ammonia vapors back to liquid ammonia. It does this by transferring the heat from the ammonia to a cooling liquid, such as water flowing through the condenser tubes. The pressure that the compressor must develop is determined by the saturation pressure of the ammonia at the temperature maintained in the condenser. (The temperature maintained in the condenser by the cooling medium is 86°F; the saturation pressure at the condenser temperature is 154 PSIG, which is the pressure that must be maintained in the condenser to change the ammonia vapor back to liquid). The liquid ammonia coming from the condenser is stored in the receiver. From here, it is ready to start the cycle over again.
6. **ACCUMULATOR** - The accumulator or low pressure receiver is not one of the essential pieces of equipment in the simple system, but in practice, it serves a very important function. For the proper operation of the compressor, it is important that no liquid ammonia can be carried over from the evaporator. The accumulator serves as a trap to keep liquid ammonia from being entered with the ammonia vapors that are pulled from the evaporator by the compressor. (The temperature and pressures are the same as they are in the evaporator). As the liquid is collected or accumulated in the accumulator, it must be removed. **THE REMOVAL OF THE LIQUID AMMONIA FROM THE ACCUMULATOR IS WHERE THE VIKING REFRIGERATION AMMONIA PUMP IS USED.**

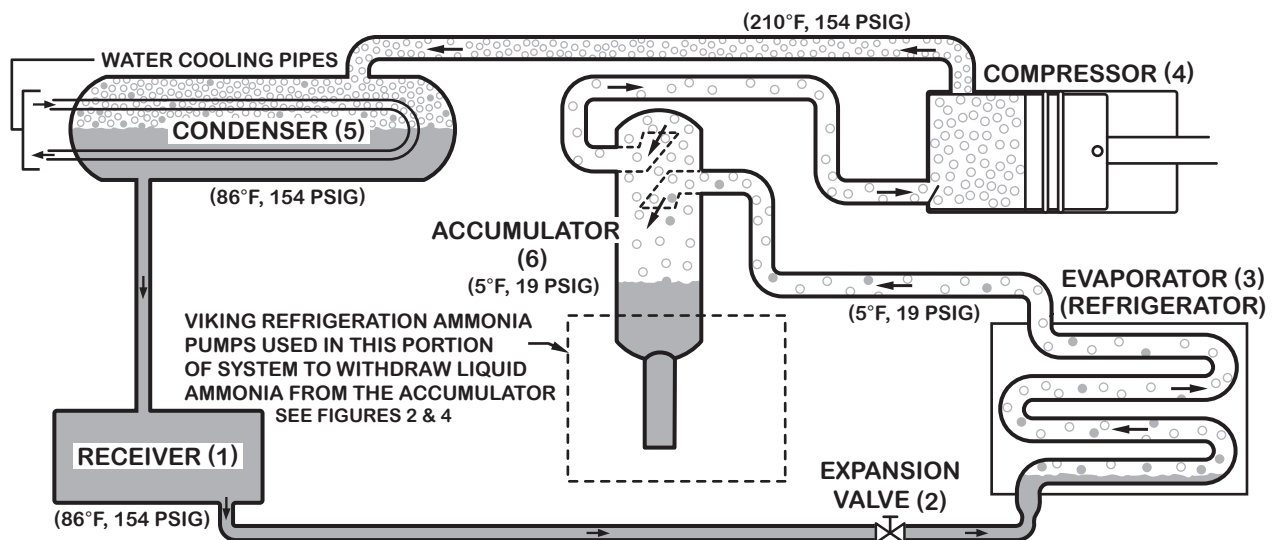

FIGURE 23
Schematic of a Simple Vapor-Compression Ammonia Refrigeration System

Figure 24 shows a typical schematic of a Continuously Recirculating System with vertical accumulator. Space or other physical requirements may make a horizontal accumulator more practical. As long as the minimum submergence requirement of 4' of liquid is maintained, the arrangement of the accumulator is of little consequence to good pump operation. The schematic is intended only to show in a general way piping and connections directly related to the pump. No attempt has been made to show all the necessary controls, valves, regulators, gauges, etc. that are necessary for successful operation of this portion of an ammonia refrigeration system.

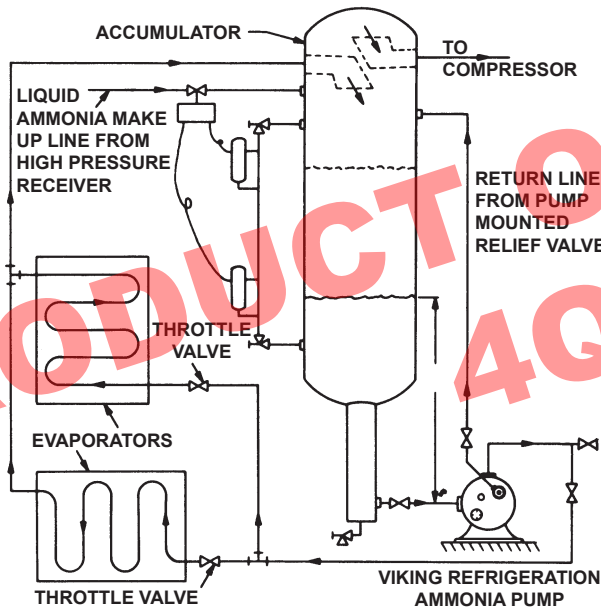

FIGURE 24
Schematic of Liquid Ammonia Recirculating System

Pumps on this system run continuously as long as there is a load on the evaporators. The evaporators are flooded with several times the amount of ammonia needed; this helps maintain an even temperature in the evaporators. The pressure or head differential across the pump is generally very low; the only head the pump must develop is that required to overcome any elevation head and any line losses.

WARRANTY

Viking warrants all products manufactured by it to be free from defects in workmanship or material for a period of one (1) year from date of startup, provided that in no event shall this warranty extend more than eighteen (18) months from the date of shipment from Viking. The warranty period for Universal Seal series pumps ONLY (Universal Seal models listed below) is three (3) years from date of startup, provided that in no event shall this warranty extend more than forty-two (42) months from the date of shipment from Viking.

UNDER NO CIRCUMSTANCES SHALL VIKING BE LIABLE UNDER THIS WARRANTY OR OTHERWISE FOR SPECIAL, INCIDENTAL, INDIRECT, CONSEQUENTIAL OR PUNITIVE DAMAGES OF ANY KIND, INCLUDING, BUT NOT LIMITED TO, LOSS OR UNREALIZED SALES, REVENUES, PROFITS, INCOME, COST SAVINGS OR BUSINESS, LOSS OR UNREALIZED CONTRACTS, LOSS OF GOODWILL, DAMAGE TO REPUTATION, LOSS OF PROPERTY, LOSS OF INFORMATION OR DATA, LOSS OF PRODUCTION, DOWNTIME, OR INCREASED COSTS, IN CONNECTION WITH ANY PRODUCT, EVEN IF VIKING HAS BEEN ADVISED OR PLACED ON NOTICE OF THE POSSIBILITY OF SUCH DAMAGES AND NOTWITHSTANDING THE FAILURE OF ANY ESSENTIAL PURPOSE OF ANY PRODUCT.

THIS WARRANTY IS AND SHALL BE VIKING'S SOLE AND EXCLUSIVE WARRANTY AND SHALL BE IN LIEU OF ALL OTHER WARRANTIES, EXPRESS OR IMPLIED, INCLUDING, BUT NOT LIMITED TO, ALL WARRANTIES OF MERCHANTABILITY, FITNESS FOR A PARTICULAR PURPOSE AND NON-INFRINGEMENT ALL OF WHICH OTHER WARRANTIES ARE EXPRESSLY EXCLUDED.

See complete warranty at www.vikingpump.com.