

# VIKING HEAVY DUTY MOTOR SPEED PUMP

Section	710
Page	710.1
Issue	E

**SERIES 4076, 4176,**  
**Sizes HLE, ATE, ALE, KE, KKE, LQE**

Viking 4076/4176 (standard pump)			
①② Flow Range	GPM	To 200 GPM	
	M <sup>3</sup> /Hr	To 45.6 M <sup>3</sup> /Hr	
① Pressure Range	KLE ALE	PSI	To 250 PSI
		BAR	To 17 BAR
	KE LQE	PSI	To 175 PSI
		BAR	To 12 BAR
① Temperature Range	°F		-40 to +300
	°C		-40 to +150
① Viscosity Range	SSU	28 SSU to 100,000 SSU	
	cPs	.1 cPs to 22,000 cSt	

## Major Design Features

- Six sizes available each with three mounting options; flange mount, motor bracket mount or with a bolt on foot for a base mount.
- Designed to run with 50Hz synchronous motor speeds while providing high capacity.
- Enlarged porting and loading groove provides improved suction performance and reduced NPSHr.
- Optimized gear geometry delivers high-speed performance with improved noise levels.
- Metric design includes DIN flanges, DIN seal chamber, IEC motor mount, metric fasteners and shaft extension.
- DIN seal chamber accepts a wide range of seal options.
- Rotor shaft is designed to resist deflection and wear seen at higher speeds.
- Circulation line from the port to the mechanical seal provides liquid to the seal faces to extend seal life.
- Bearing housing assembly allows for adjustment of running clearances to compensate for slip and wear, extending the service life of the pump. Also provides additional shaft support in high pressure applications, and provides a method of shaft support other than the motor bearing.
- Ductile iron externals for thermal shock applications is an affordable alternative to steel.

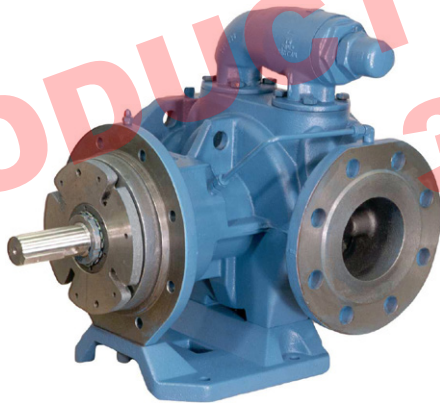

LQE4176 WITH BOLT ON FOOT



LQE4076 WITH FOOT BRACKET AND IEC MOTOR

① Values shown represent minimums or maximums. Some special construction or consideration may be required before a cataloged pump can be applied to an application involving maximum pressure or minimum or maximum temperature and/or viscosity.

② Nominal capacities based on handling thin liquids at low pressures.

Section	710
Page	710.2
Issue	E

## VIKING HEAVY DUTY MOTOR SPEED PUMP

**SERIES 4076, 4176,  
Sizes HLE, ATE, ALE, KE, KKE, LQE**

### CONSTRUCTION – SPECIFICATIONS

Standard	Casing and Head ① ⑤	Foot Plate ②	Rotor ③	Idler ④	Rotor Shaft and Idler Pin	Bushings		Mechanical Seal ⑥	Relief Valve ⑦	Elastomers
						Idler	Casing			
	Ductile Iron  ASTM A536 Grade 60-40-18	Ductile Iron  ASTM A536 Grade 60-40-18	Ductile Iron  ASTM A536 Grade 60-40-18	Cast Iron  ASTM A48-64 Class 35B	Steel  ASTM A108 Grade 1045	Carbon Graphite	Carbon Graphite	Buna N / silicon carbide vs carbon	Ductile Iron  ASTM A536 Grade 60-40-18	Buna N
Options	---	---	Steel ASTM A148 Grade 80-40	---	---	---	---	Viton / silicon carbide vs carbon	---	Viton®

① Clockwise (CW) rotation standard. Counterclockwise (CCW) rotation must be specified.

② Used on 4176 models only.

③ KE and LQE models have cast iron rotor as standard.

④ ATE and ALE models have ductile iron idler.

⑤ Ductile iron jacketed head plate available as an option for all sizes.

⑥ Standard mechanical seal can be used for temperatures from -40° F to +400° F (-40° to +205° C) and viscosities to 3500 SSU (750 cSt). Pin style seal is recommended above 3500 SSU with a maximum of viscosity of 10,000 SSU (25,00 cSt). For applications with viscosities above 3,500 SSU refer to Technical Reference document TR 300 or contact factory for seal recommendations.

⑦ All relief valves are set at 100 PSI (7 bar) unless otherwise ordered. If a Viking over-pressure relief valve is not used, the pumping system should include some form of over-pressure protection, e.g. a valve in the discharge line, torque limiting device, or rupture discs.

Dimensions for Unmounted Pumps – See Pages 710.4

### SPECIFICATIONS - UNMOUNTED PUMPS

Model Number	⑧ Port Size (DIN)	⑨ Nominal Pump Capacity					Maximum Hydrostatic Pressure		⑩ Maximum Recommended Discharge Pressure, 25 cSt Liquid		Maximum Temperature	
		Theoretical		GPM	M <sup>3</sup> /Hr	RPM	PSI	BAR	PSI	BAR	Deg. F.	Deg. C.
		Gal/Rev	Litres/Rev									
HLE4076 HLE4176	40	0.02	0.07	26	5.9	1450	300	21	250	17	300	150
ATE4076 ATE4176	65	0.04	0.15	54	12.1	1450	300	21	250	17	300	150
ALE4076 ALE4176	65	0.07	0.26	94	21.4	1450	300	21	250	17	300	150
KE4076 KE4176	80	0.09	0.35	126	28.8	1450	300	21	175	12	300	150
KKE4076 KKE4176	80	0.13	0.46	170	38.4	1450	300	21	175	12	300	150
LQE4076 LQE4176	100	0.22	0.82	200	45.6	970	300	21	175	12	300	150

⑧ Pumps standard with DIN ports.

⑨ Nominal rating based on handling thin liquids. Capacities rounded to the nearest whole number.

⑩ For maximum recommended discharge pressures at rated speeds or when handling other viscosities and/or speeds, see performance curves, which can be electronically generated with the Viking Pump Selector Program, located on [www.vikingpump.com](http://www.vikingpump.com). If suction pressure exceeds 3 BAR, consult factory.

1 BAR = 14.5 PSI = 0.1 MPa = 100 kPa = 10<sup>5</sup> Pa.

Viton® - is a registered trademark of DuPont Performance Elastomers.

# VIKING HEAVY DUTY MOTOR SPEED PUMP

SERIES 4076, 4176,  
Sizes HLE, ATE, ALE, KE, KKE, LQE

Section	710
Page	710.3
Issue	E

## PARTS IDENTIFICATION

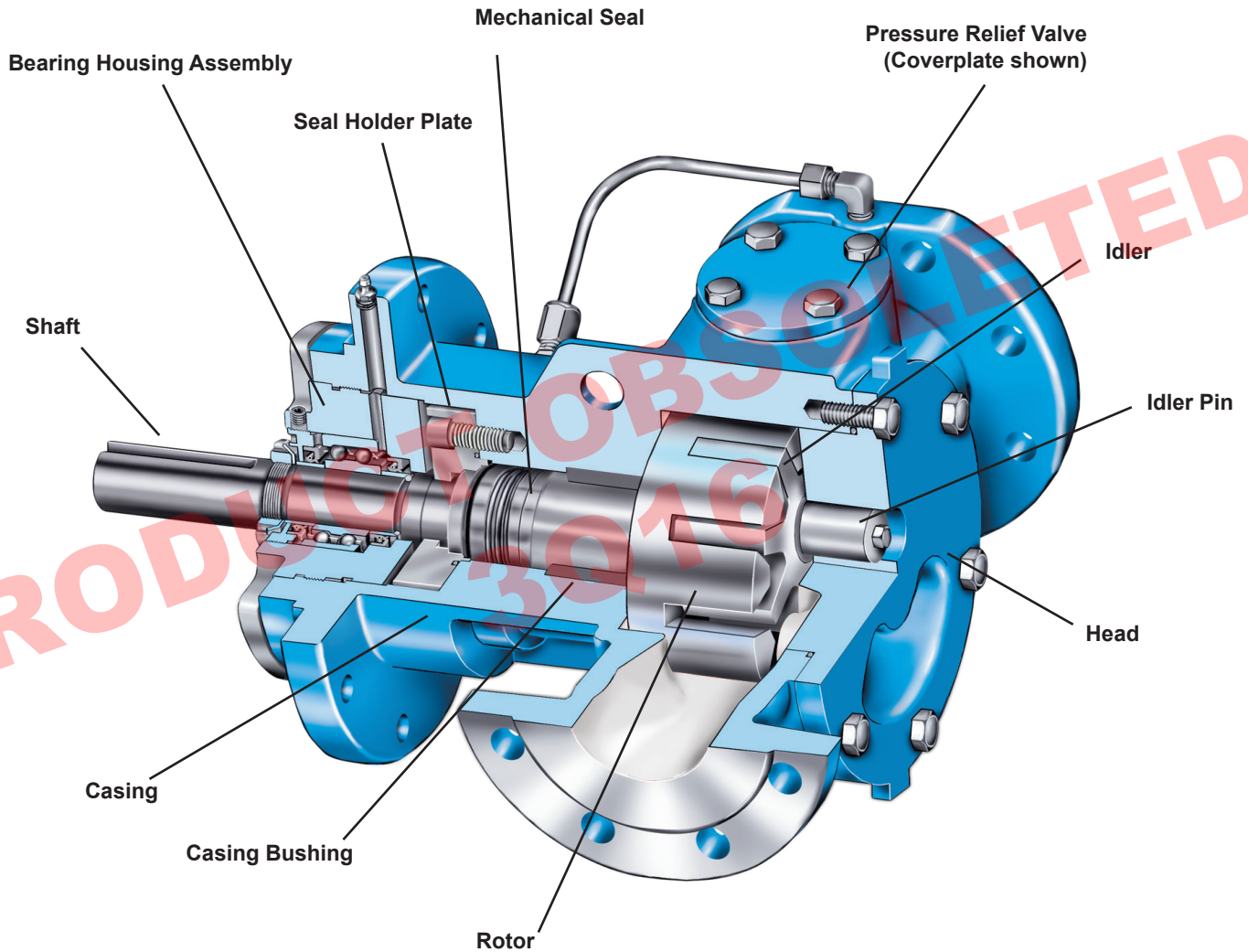

Section	710
Page	710.4
Issue	E

## VIKING HEAVY DUTY MOTOR SPEED PUMP

**SERIES 4076, 4176,  
Sizes HLE, ATE, ALE, KE, KKE, LQE**

*Dimensions given are for guidance only and should not be used for installation purposes.  
Certified dimensions will be supplied on request.*

### DIMENSIONS – HLE4076 - LQE4076 PUMP ONLY

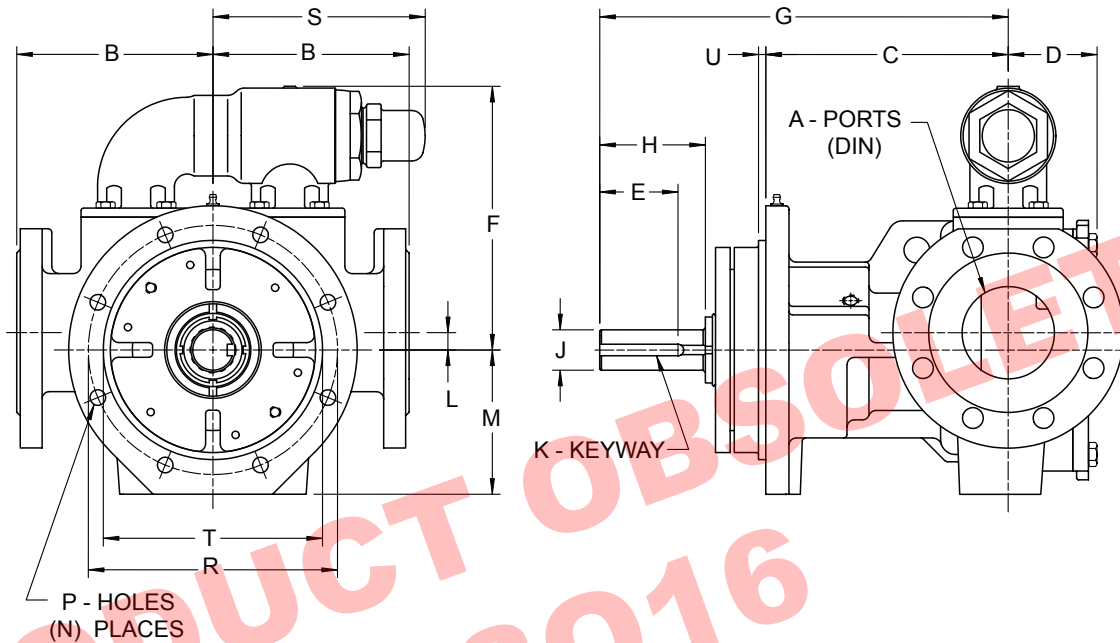

All dimensions are in millimeters.

MODEL NUMBER	A	B	C	D	E	F	G	H	J	K	L	M	N	P	R	S	T	U	Pump Weight Kg (lb)
HLE4076	DIN 40 PN 16/25/40	105	175	58	41	141	275	52	19	6 X 3.5	0	70				89	110	3	23 (51)
ATE4076 ALE4076	DIN 65 PN 25/40	150	200	82	46	207	302	57	25	8 X 4		85	4	13.5	145	154			45 (100)
KE4076 KKE4076	DIN 80 PN 16/25/40	170	210	97		228	354				15								65 (145)
LQE4076	DIN 100 PN 25/40	185	235	85	68	253	379	92	35	10 X 5	0	125	8	13.5	216	184	190	6	86 (190)

# VIKING HEAVY DUTY MOTOR SPEED PUMP

Section	710
Page	710.5
Issue	E

**SERIES 4076, 4176,**  
**Sizes HLE, ATE, ALE, KE, KKE, LQE**

*Dimensions given are for guidance only and should not be used for installation purposes.  
 Certified dimensions will be supplied on request.*

## DIMENSIONS – HLE4176 - LQE4176 PUMP ONLY

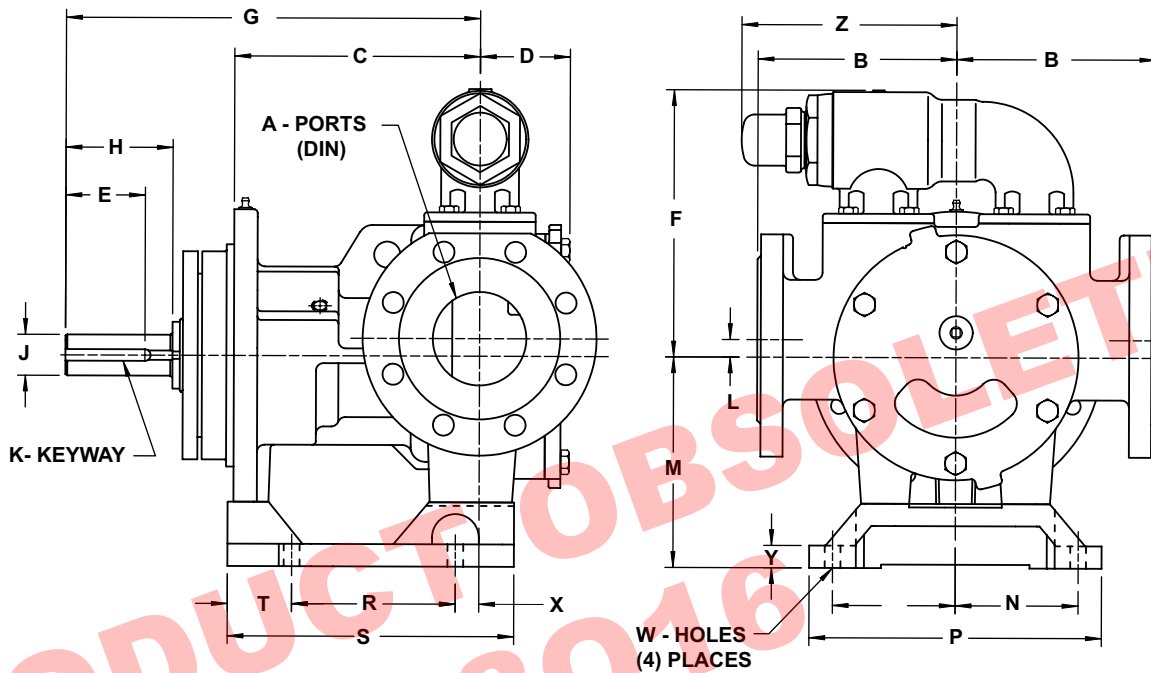

All dimensions are in millimeters.

MODEL NUMBER	A	B	C	D	E	F	G	H	J	K	L	M	N	P	R	S	T	W	X	Y	Z	Pump Weight Kg (lb)
<b>HLE 4176</b>	DIN 40 PN 16/25/40	105	175	58	41	141	275	52	19	6 X 3.5	0	112	65	160	110	211	65	11	0	13	89	27 (60)
<b>ATE4176</b> <b>ALE4176</b>	DIN 65 PN 25/40	150	200	82	46	207	302	57	25	8 X 4		132	85	203	110		70		20		154	50 (110)
<b>KE4176</b> <b>KKE4176</b>	DIN 80 PN 16/25/40	170	210	97	68	228	354	92	35	10 X 5	15	180	105	250	140	245	55	13.5	20	19	184	75 (165)
<b>LQE4176</b>	DIN 100 PN 25/40	185	235	85		253	379				0	180	105	250	140	245	55	13.5	45	19		96 (210)

Section	710
Page	710.6
Issue	E

## VIKING HEAVY DUTY MOTOR SPEED PUMP

**SERIES 4076, 4176,  
Sizes HLE, ATE, ALE, KE, KKE, LQE**

*Dimensions given are for guidance only and should not be used for installation purposes.  
Certified dimensions will be supplied on request.*

### DIMENSIONS- BRACKET MOUNT SIZES HLE, ATE, AND ALE

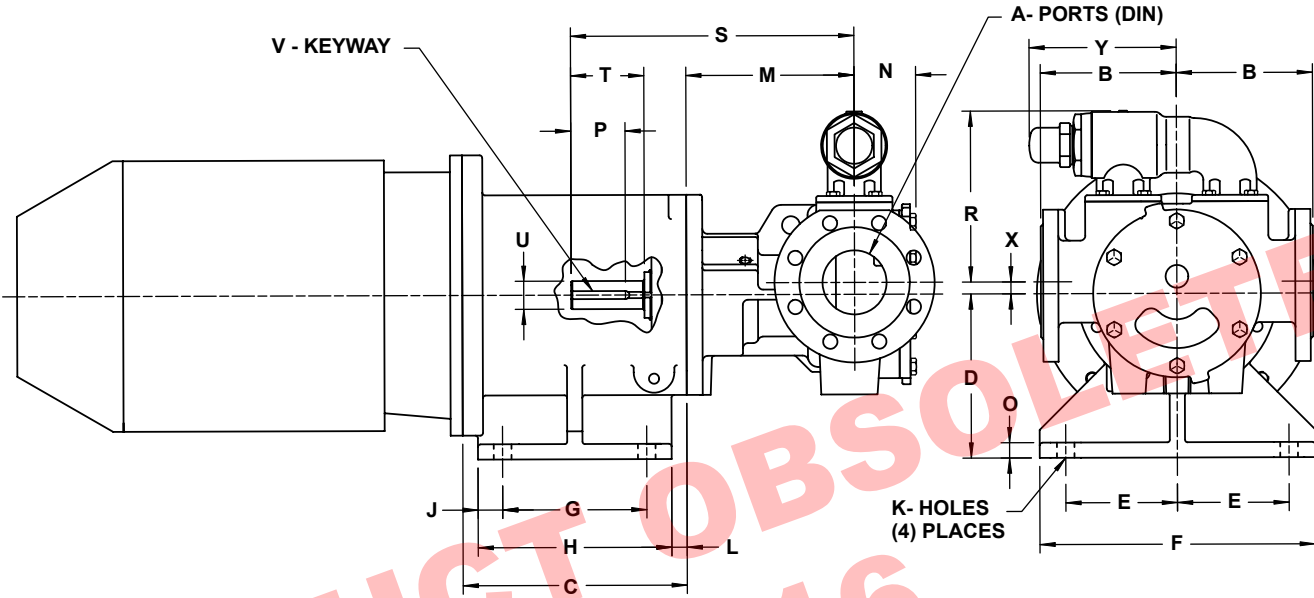

All dimensions are in millimeters.

MODEL NUMBER.	A	B	M	N	P	R	S	T	U	V	X	Y	MOTOR FRAME	C	D	E	F	G	H	J	K	L	O	Bracket Weight kg (lb)
HLE4076M HLE4176M	DIN 40 PN 16/25/40	105	175	58	41	141	275	52	19	6 X 3.5	0	89	80 (B5)	155	125	75	190	100	140	27	14.5	8	19	14 (31)
													90 (B5)	165	125	75	190	100	140	33	14.5	13	19	15 (33)
													100 (B5)	185	145	75	190	120	169	33	14.5	8	19	18 (40)
ATE4076M ATE4176M ALE4076M ALE4176M	DIN 65 PN 25/40	150	175	82	46	207	302	57	25	8 X 4	0	154	112 (B5)	205	140	75	190	130	180	38	14.5	13	19	18 (40)
													132 (B14)	240	165	75	190	175	224	33	14.5	8	19	23 (52)
													160 (B14)	240	165	75	190	175	224	33	14.5	8	19	23 (52)

Metric shaft couplings and key required.

# VIKING HEAVY DUTY MOTOR SPEED PUMP

Section	710
Page	710.7
Issue	E

**SERIES 4076, 4176,**  
**Sizes HLE, ATE, ALE, KE, KKE, LQE**

*Dimensions given are for guidance only and should not be used for installation purposes.  
 Certified dimensions will be supplied on request.*

## DIMENSIONS- BRACKET MOUNT SIZES KE,KKE, AND LQE

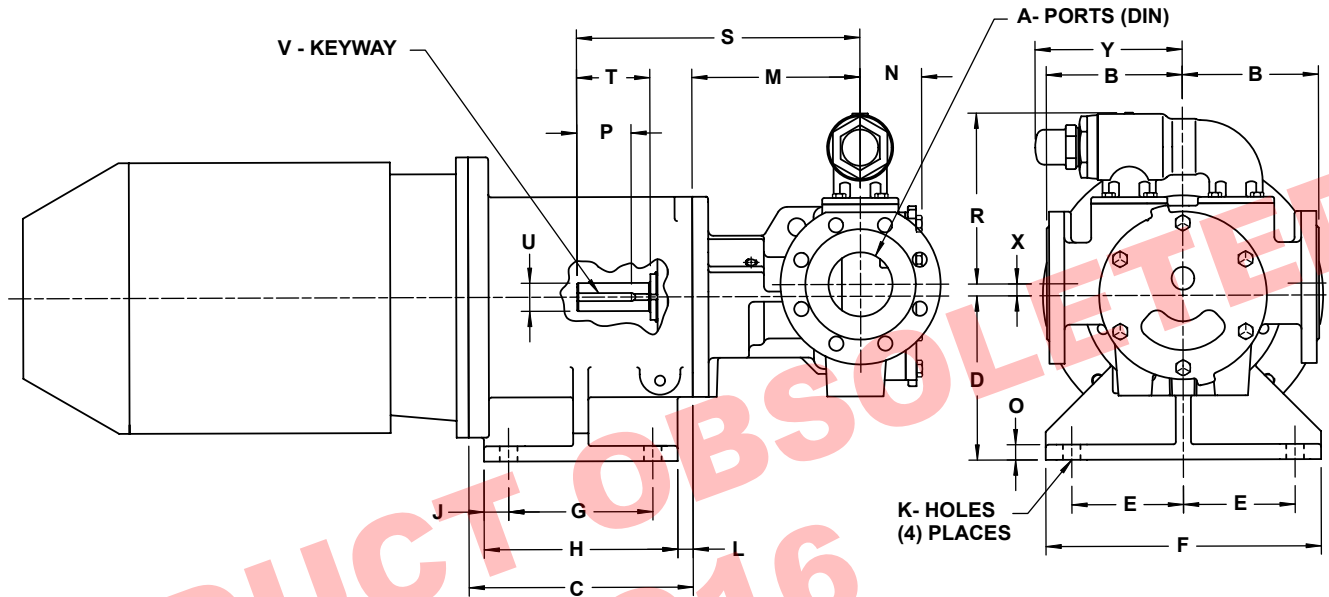

All dimensions are in millimeters.

MODEL NUMBER	A	B	M	N	P	R	S	T	U	V	X	Y	MOTOR FRAME	C	D	E	F	G	H	J	K	L	O	Bracket Weight kg (lb)										
KE4076M KKE4176M	DIN 80 PN 16/25/40	170	210	97	68	228	354	92	35	10 X 5	15	184	100 (B5)	230	170	90	229	150	202	26	19	14	19	45 (100)										
													112 (B5)																					
													132 (B5)	250	180	95	255	180	222	21	19	9	19	50 (112)										
LQE4076M LQE4176M	DIN 100 PN 25/40	185	235	85		253	379				0		160 (B5)	205	140	75	190	130	180	38	14.5	13	19	60 (133)										
													180 (B5)	280	205	139	344	180	224	31	22	19	19											



Section	710
Page	710.8
Issue	E

## VIKING HEAVY DUTY MOTOR SPEED PUMP

**SERIES 4076, 4176,  
Sizes HLE, ATE, ALE, KE, KKE, LQE**

---

### Performance Curve Notes

Printed performance curves are not available.

Performance curves can be electronically generated with the Viking Pump Selector Program. This program can be located on [www.vikingpump.com](http://www.vikingpump.com) for the general public.

For authorized distributors, this program can be found listed under the "Products" tab at [www.idexconnect.com](http://www.idexconnect.com). Security passwords are required to access IDEXconnect.

**PRODUCT OBSOLETE**  
**3Q16**