

GB-414 SERIES™

GENERATION 3 REBUILDABLE PIPELINE INJECTION PUMP

FEATURES & BENEFITS

DIMENSIONALLY INTERCHANGEABLE WITH NORTHERN® 4900 SERIES

- Pump dimensions match *existing* motor, base & piping
- Dual ports eliminate costly piping modifications
- Spare pumps available in stock for immediate shipment on a first-come-first-serve basis

SIMPLE, FIELD-REBUILDABLE DESIGN

- Simple disassembly and reassembly process saves time and money
- Rebuild *where* and *when* you need it
- Complete rebuild kit brings the pump back to as-new operating condition

RELIABLE SEALING SOLUTION

- Type 2 bellows seal with standard 200 PSI inlet rating reduces the leak risk and expense of multiple seals per pump
- Robust axial thrust control bearing reduces premature seal failure due to elevated inlet pressure, starts, stops, and other difficult application conditions

MODULAR PORT DESIGN

- Standard 180° SAE or 2" NPT ports fit into existing piping location of competitive gear pumps

COMPACT FOOTPRINT

- 7' unit length on largest pump and motor assembly
- Motor speed operation eliminates the need for gear reducers or belt drives
- Units include small, rigid formed steel baseplate complete with spacer coupling and coupling guard

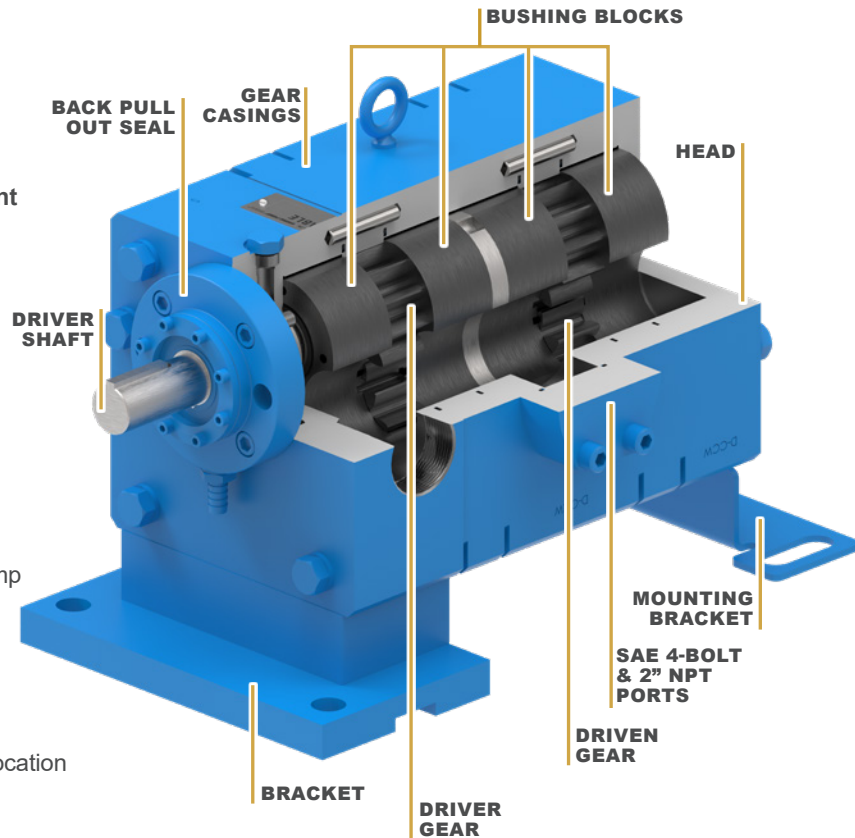

PERFORMANCE

Pump Model	Port Size & Type*	Nominal Flow @ 200 PSI (1,775 rpm) on 4 cP		Nominal Flow @ 400 PSI (1,775 rpm) on 4 cP		Nominal Flow @ 600 PSI (1,775 rpm) on 4 cP		Nominal Flow @ 750 or 800 PSI (1,775 rpm) on 4 cP		Nominal Flow @ 1000 PSI (1,775 rpm) on 4 cP		Max Continuous Pressure
		GPM	BPD	GPM	BPD	GPM	BPD	GPM	BPD	GPM	BPD	PSI
Viking Pump® GB-41430	2" SAE & 2" NPT	105	3620	100	3455	96	3311	92	3180	89	3061	1500
Competitor 4900-10	2" NPT	64	2194	60	2057	56	1920	52	1783	49	1680	1440
Competitor 4900-15	2" NPT	96	3291	92	3154	88	3017	83	2846	79	2709	1165
Viking Pump® GB-41440	3" SAE & 2" NPT	136	4691	130	4467	124	4275	120	4144	-	-	750
Competitor 4900-20	2" NPT	129	4423	124	4251	119	4080	114	3909	-	-	875
Competitor 4900-25	2" NPT	162	5554	156	5349	150	5143	-	-	-	-	700

* 2" and 3" SAE ports use J518 Code 61 SAE flange ports.

For more information, visit vikingpump.com/drop-in-replacement

REPLACEABLE INTERNALS

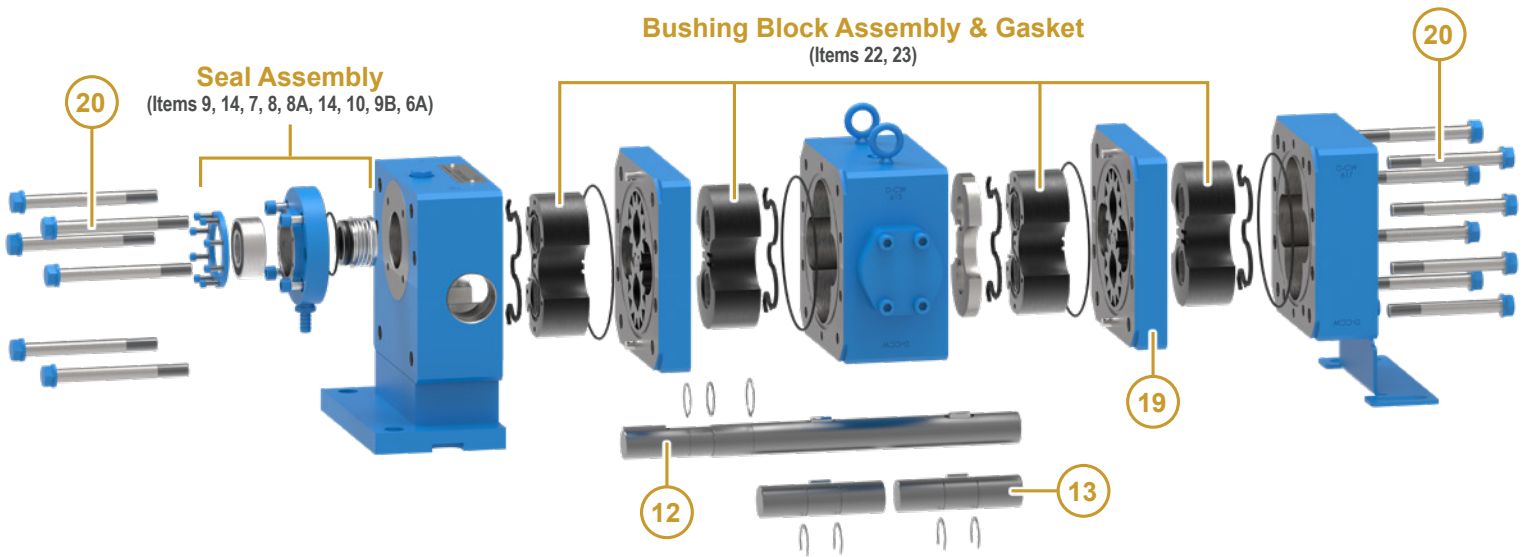

Item	Name of Part	Seal Kit	Complete Rebuild Kit
1	Bracket		
6	Seal Holder		
6A	Cap Screws	✓	✓
7	Seal Holder Oring	✓	✓
8	Mech Seal - FKM/Sil- Cab	✓	✓
8A	Seal Washer	✓	✓
9	Dbl Row Ball Bearing	✓	✓
9A	Bearing End Cap		
9B	Cap Screws	✓	✓
10	Beveled Retaining Ring	✓	✓
11	Section Orings		✓
12	Driver Shaft		✓
13	Driven Shaft		✓
14	Retaining Ring	✓	✓

Item	Name of Part	Seal Kit	Complete Rebuild Kit
14A	Retaining Ring (Seal)	✓	✓
14B	Retaining Ring (Gears)		✓
15	Gear Pin		✓
19	Casing & Gear Set		✓
20	Cap Screws (Bracket)		✓
20	Cap Screws (Head)		✓
20A	Lock Washer		✓
22	Bushing Assembly		✓
23	Gasket		✓
24	Separation Plate Spacer		
26	Shaft Key		✓
27	Head		
29	Separation Plate - With Ports		

NOTE: Some items included in the rebuild kit not called out in above image. Contact your Viking Pump® representative for additional Rebuild Kit details.



VIKING PUMP, INC.
 A Unit of IDEX Corporation
 406 State Street
 Cedar Falls, Iowa 50613 U.S.A.
vikingpump.com

**CONTACT YOUR
 VIKING PUMP®
 OIL & LACT PUMP
 SPECIALISTS**

vikingpump.com/drop-in-replacement

