

**TECHNICAL SERVICE MANUAL: INSTALLATION, OPERATION & MAINTENANCE**



UNIVERSAL PRODUCT LINE: *STAINLESS STEEL*

127C SERIES™, 1127C SERIES™, 4127C SERIES™,  
227C SERIES™, 1227C SERIES™, 4227C SERIES™

**SIZES: H, HL, K, KK, L, LL, LS, Q, QS**

TSM	2700
Page	1 of 26
Issue	A

**TABLE OF CONTENTS**

Model Number Chart..... 1  
 Introduction ..... 1  
 Safety Information & Instructions ..... 2  
 Special Information ..... 3  
     *Rotation* ..... 3  
     *Circulation Lines* ..... 3  
     *Suckback & Flush Holes* ..... 3  
     *Jacketed Ports* ..... 3  
     *Pressure Relief Valves* ..... 3  
     *Mechanical Seals* ..... 3  
 Maintenance ..... 3  
     *Lubrication* ..... 3  
     *Packing Adjustment* ..... 3  
     *Cleaning Pump* ..... 4  
     *Storage* ..... 4  
     *Suggested Repair Tools* ..... 4  
 Removal: Cartridge Mechanical Seal ..... 7  
 Installation: Cartridge Mechanical Seal ..... 7  
 Removal: Component Mechanical Seal ..... 8  
 Installation: Component Mechanical Seal ..... 8  
 Removal: Behind the Rotor Mechanical Seal ..... 9  
 Installation: Behind the Rotor Mechanical Seal ..... 9  
 Removal: O-Pro® Guard Seal ..... 10  
 Installation: O-Pro® Guard Seal ..... 10  
 Removal: Packing ..... 11  
 Installation: Packing ..... 11  
 Pump Disassembly ..... 11  
 Pump Assembly ..... 13  
 Pump Flange Assembly ..... 14  
 Thrust Bearing Adjustment ..... 14  
 Installation: Carbon Graphite Bushings ..... 15  
 Bracket Bushing Installation: Stuffing Box Seals ..... 15  
 Bracket Bushing Installation: Behind the Rotor Seal ..... 15  
 Pressure Relief Valve Instructions ..... 16  
     *Disassembly* ..... 16  
     *Assembly* ..... 16  
     *Pressure Adjustment* ..... 16  
     *Important Ordering Information* ..... 16  
 APPENDIX (Formerly TSM 000) ..... 17  
 General Installation Notes ..... 17  
 Foundation ..... 18  
 Component & Unit Lifting Features ..... 18  
 Alignment ..... 20  
 Piping ..... 20  
 Start Up ..... 21  
 Troubleshooting ..... 22  
     *Vacuum Gauge - Suction Port* ..... 22  
     *Pressure Gauge - Discharge Port* ..... 22  
 Rapid Wear ..... 23  
 Preventative Maintenance ..... 24  
 Do's & Don'ts ..... 24  
     *Installation* ..... 24  
     *Operation* ..... 24  
     *Maintenance* ..... 25  
 ESB-515 ..... 25  
     *Lubrication of Viking Pumps* ..... 25  
     *Lubrication of Viking Reducers* ..... 25  
     *Lubrication of Viking Associative Equipment* ..... 25

**MODEL NUMBER CHART**

NON-JACKETED			JACKETED		
Packed	O-Pro® Guard Seal	Mech. Seal	Packed	O-Pro® Guard Seal	Mech. Seal
H127C	H1127C	H4127C	H227C	H1227C	H4227C
HL127C	HL1127C	HL4127C	HL227C	HL1227C	HL4227C
K127C	K1127C	K4127C	K227C	K1227C	K4227C
KK127C	KK1127C	KK4127C	KK227C	KK1227C	KK4227C
L127C	L1127C	L4127C	L227C	L1227C	L4227C
LL127C	LL1127C	LL4127C	LL227C	LL1227C	LL4227C
LS127C	LS1127C	LS4127C	LS227C	LS1227C	LS4227C
Q127C	Q1127C	Q4127C	Q227C	Q1227C	Q4227C
QS127C	QS1127C	QS4127C	QS227C	QS1227C	QS4227C

**INTRODUCTION**

*The illustrations used in this manual are for identification purposes only and cannot be used for ordering parts.*  
 Obtain a parts list from your Viking Pump® representative. Always give a complete name of part, part number and material with the model number and serial number of pump when ordering repair parts. The unmounted pump or pump unit model number and serial number are on the nameplate. This manual only applies to the pump models specified in the "Model Number Chart" on page 1. Pump specifications and recommendations are listed in the Catalog Sections, which are available at vikingpump.com.

**FIGURE 1: H, HL SIZES**  
(HL127C SHOWN)



**FIGURE 2: K, KK SIZES**  
(KK1227C SHOWN)



**FIGURE 3: L, LL, LS SIZES**  
(LL127C SHOWN)



**FIGURE 4: Q, QS SIZES**  
(QS4227C SHOWN)



# SAFETY INFORMATION & INSTRUCTIONS

IMPROPER INSTALLATION, OPERATION OR MAINTENANCE OF PUMP MAY CAUSE SERIOUS INJURY OR DEATH, AND/OR RESULT IN DAMAGE TO PUMP AND/OR OTHER EQUIPMENT. VIKING'S WARRANTY DOES NOT COVER FAILURE DUE TO IMPROPER INSTALLATION, OPERATION OR MAINTENANCE.

THIS INFORMATION MUST BE FULLY READ BEFORE BEGINNING INSTALLATION, OPERATION OR MAINTENANCE OF PUMP, AND MUST BE KEPT WITH PUMP. PUMP MUST BE INSTALLED, OPERATED AND MAINTAINED ONLY BY SUITABLY TRAINED AND QUALIFIED PERSONS.

THE FOLLOWING SAFETY INSTRUCTIONS MUST BE FOLLOWED AND ADHERED TO AT ALL TIMES.

 **DANGER** = FAILURE TO FOLLOW THE INDICATED INSTRUCTION MAY RESULT IN SERIOUS INJURY OR DEATH.

 **WARNING** = IN ADDITION TO SERIOUS INJURY OR DEATH, FAILURE TO FOLLOW THE INDICATED INSTRUCTION MAY CAUSE DAMAGE TO PUMP AND/OR OTHER EQUIPMENT

## **DANGER**

**BEFORE** opening any liquid chamber (pumping chamber, reservoir, relief valve adjusting cap fitting, etc.) be sure that:

- Any pressure in the chamber has been completely vented through the suction or discharge lines or other appropriate openings or connections.
- The pump drive system (motor, turbine, engine, etc.) has been "locked out" or otherwise been made non-operational, so that it cannot be started while work is being done on the pump.
- You know what material the pump has been handling, have obtained a material safety data sheet (MSDS) for the material, and understand and follow all precautions appropriate for the safe handling of the material.

## **DANGER**

**BEFORE** operating the pump, be sure all drive guards are in place.

## **DANGER**

**DO NOT** operate pump if the suction or discharge piping is not connected.

## **DANGER**

**DO NOT** place fingers into the pumping chamber, or its connection ports, or into any part of the drive train if there is any possibility of the pump shaft being rotated.

## **WARNING**

**DO NOT** exceed the pumps rated pressure, speed, and temperature, or change the system/duty parameters from those the pump was originally supplied, without confirming its suitability for the new service.

## **WARNING**

**BEFORE** operating the pump, be sure that:

- It is clean and free from debris.
- All valves in the suction and discharge pipelines are fully opened.
- All piping connected to the pump is fully supported and correctly aligned with the pump.
- Pump rotation is correct for the desired direction of flow.

## **WARNING**

**INSTALL** pressure gauges/sensors next to the pump suction and discharge connections to monitor pressures.

## **WARNING**

**USE** extreme caution when lifting the pump. Suitable lifting devices should be used when appropriate. Lifting eyes installed on the pump must be used only to lift the pump, not the pump with drive and/or base plate. If the pump is mounted on a base plate, the base plate must be used for all lifting purposes. If slings are used for lifting, they must be safely and securely attached. For weight of the pump alone (which does not include the drive and/or base plate) refer to the Viking Pump® product catalog.

## **DANGER**

**DO NOT** attempt to dismantle a pressure relief valve that has not had the spring pressure relieved or is mounted on a pump that is operating.

## **DANGER**

**AVOID** contact with hot areas of the pump and/or drive. Certain operating conditions, temperature control devices (jackets, heat-tracing, etc.), improper installation, improper operation, and improper maintenance can all cause high temperatures on the pump and/or drive.

## **WARNING**

**THE PUMP** must be provided with pressure protection. This may be provided through a relief valve mounted directly on the pump, an in-line pressure relief valve, a torque limiting device, or a rupture disk. If pump rotation may be reversed during operation, pressure protection must be provided on both sides of pump. Relief valve adjusting screw caps must always point towards suction side of the pump. If pump rotation is reversed, position of the relief valve must be changed. Pressure relief valves cannot be used to control pump flow or regulate discharge pressure. For additional information, refer to **Appendix, General Installation Notes**, item 5 on Pressure Protection or contact your Viking Pump® representative for Engineering Service Bulletin ESB-31.

## **WARNING**

**THE PUMP** must be installed in a manner that allows safe access for routine maintenance and for inspection during operation to check for leakage and monitor pump operation.

## SPECIAL INFORMATION

### ROTATION

Viking pumps can operate equally well in a clockwise or counter-clockwise rotation; however, some constructions may require modifications. Consult your Viking Pump® representative if unsure. Shaft rotation determines which port is suction and which is discharge. Suction port is where pumping elements (gear teeth) come out of mesh.

If pump rotation is reversed during operation, pressure protection must be provided on both sides of pump.

Relief valve adjusting screw cap must always point towards suction side of pump. If pump rotation is reversed, remove pressure relief valve and turn end for end.

### CIRCULATION LINES

This equipment (not utilized on all pumps) must be connected properly. Packed pumps typically have a flush line from packing chamber to **discharge** port. Mechanical seal pumps typically have a suckback line from seal chamber to suction port. If pump rotation is reversed, be sure circulation connections are connected to the suction or discharge port as noted above to avoid excessive leakage or damage to pump. If pump is handling heated product, be sure circulation line is insulated to assure continued flow.

### SUCKBACK & FLUSH HOLES

Typically, both suction and discharge ports will have pipe plugs installed in the tapped hole inside the ports. When needed for added circulation behind the rotor, the suction port hole will be open, or both the suction and discharge port hole will be open. For further details contact your Viking Pump representative.

## ⚠ WARNING !

**When replacing a pump casing, pay attention to the use of the pipe plugs inside the ports and install to match the previous configuration.**

Pumps with Pro-Port™ casing come equipped with a feature that allows for increased flow of liquid to the back side of the rotor. In each port is a hole that is plugged with a pipe plug by default. When pumping high viscosity products (>23,000 SSU) which are prone to solidification, these pipe plugs can be removed to encourage the movement of the liquid behind the pump rotor. At viscosities below 23,000 SSU, leaving these holes unplugged can result in a lower than expected pump performance. Typically only one pipe plug would be removed from the suction port to promote flow behind the rotor. If pump rotation is changed, the use of this feature would have to be updated accordingly. Careful attention should be taken to ensure that pipe plugs are securely installed as loose setscrews could damage pump internals if they become unseated.

### JACKETED PORTS

Jackets are utilized to heat (or cool) the pump and liquid in the pump prior to startup. Not all pumps have ports for jacketing. Jacketing port locations vary by model.

### PRESSURE RELIEF VALVES

1. Viking pumps are positive displacement pumps and must be provided with some sort of pressure protection. This may be a relief valve mounted directly on the pump, an inline pressure relief valve, a torque limiting device or a rupture disk.

2. There are relief valve options available on those pump models designed to accept a relief valve. Options may include a jacketed relief valve or return to tank relief valve.
3. If pump rotation is reversed during operation, pressure protection must be provided on **both** sides of pump.
4. Relief valve adjusting screw cap must always point towards suction side of pump, see "**Figure 5**" on page 3. If pump rotation is reversed, remove pressure relief valve and turn end for end.
5. Pressure relief valves cannot be used to control pump flow or regulate discharge pressure.

For additional information on pressure relief valves, Refer to **Appendix, General Installation Notes**, item 5 on Pressure Protection or contact your Viking Pump® representative for Engineering Service Bulletin ESB-31.

### MECHANICAL SEALS

Extra care should be taken in repair of pumps with mechanical seals. Be sure to read and follow all special instructions supplied with your pump.

FIGURE 5: RELIEF VALVE POSITION

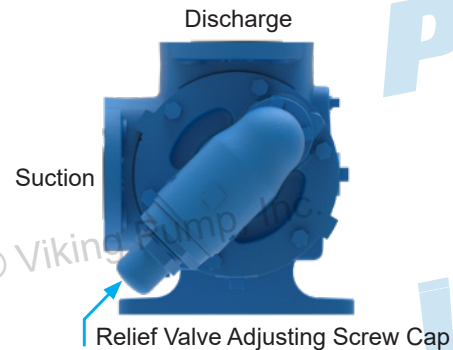

## MAINTENANCE

These pumps are designed for long, trouble-free service life under a wide variety of application conditions with minimum maintenance. The points listed below will help provide long service life.

### LUBRICATION

External lubrication must be applied slowly with a hand gun to all lubrication fittings every 500 hours of operation with multi-purpose grease, NLGI # 2. Contact your Viking Pump® representative with specific lubrication questions. **Engineering Service Bulletin ESB-515** is located in the **Appendix** for standard grease thickener types used by Viking to check compatibility. Applications involving very high or low temperatures will require other types of lubrication. O-Pro® seals should also be greased every 500 hours of operation with a lubricating fluid compatible with the process fluid.

### PACKING ADJUSTMENT

New packed pumps require initial packing adjustment to control leakage as packing "runs in". Make initial adjustments carefully and do not over-tighten packing gland. After initial adjustment, inspection will reveal need for packing gland adjustment or packing replacement. Contact your Viking Pump® representative for Engineering Service Bulletin ESB-521 regarding repacking pump.

## CLEANING PUMP

Keep pump as clean as possible. This will facilitate inspection, adjustment and repair work and help prevent overlooking a dirt covered grease fitting.

## STORAGE

If pump is to be stored, or not used for six months or more, pump must be drained and a light coat of non-detergent SAE 30 weight oil must be applied to all internal pump parts.

Lubricate fittings and apply grease to pump shaft extension. Viking suggests rotating pump shaft by hand one complete revolution every 30 days to circulate the oil. Tighten all pump assembly bolts before putting pump in service after being stored.

## SUGGESTED REPAIR TOOLS

The following tools must be available to properly repair these pumps. These tools are in addition to standard mechanics' tools such as open-end wrenches, pliers, screwdrivers, etc. Most of the items can be obtained from an industrial supply house.

1. Soft Headed hammer
2. Allen wrenches (Some mechanical seals, set collars, internal circulation pipe plugs, and ports)
3. Packing hooks, flexible (packed pumps)
4. Seal installation sleeves for mechanical and O-Pro® Seals  
2-751-002-730 for 1.125 inch seal; H-HL pumps  
2-751-003-730 for 1.4375 inch seal; K-KK pumps  
2-751-005-730 for 2.437 inch seal; Q-QS pumps  
No sleeve needed for L-LS pumps
5. Bearing locknut spanner wrench  
Source: #471 J.H. Williams & Co. or Equal; H-KK Pumps  
Source: #472 J.H. Williams & Co. or Equal; L-QS Pumps
6. Spanner wrench, adjustable pin type for bearing housing and end cap  
Source: #482 J. H. Williams & Co. or equal; H-QS pumps
7. Brass or plastic bar
8. Arbor press
9. Torque wrench

Contact your Authorized Viking Pump® stocking distributor for available seal and rebuild kits

FIGURE 6: EXPLODED VIEW (H, HL SIZES) — IMAGE IS REPRESENTATIVE ONLY  
127C SERIES™, 1127C SERIES™, 4127C SERIES™, 227C SERIES™, 1227C SERIES™, 4227C SERIES™

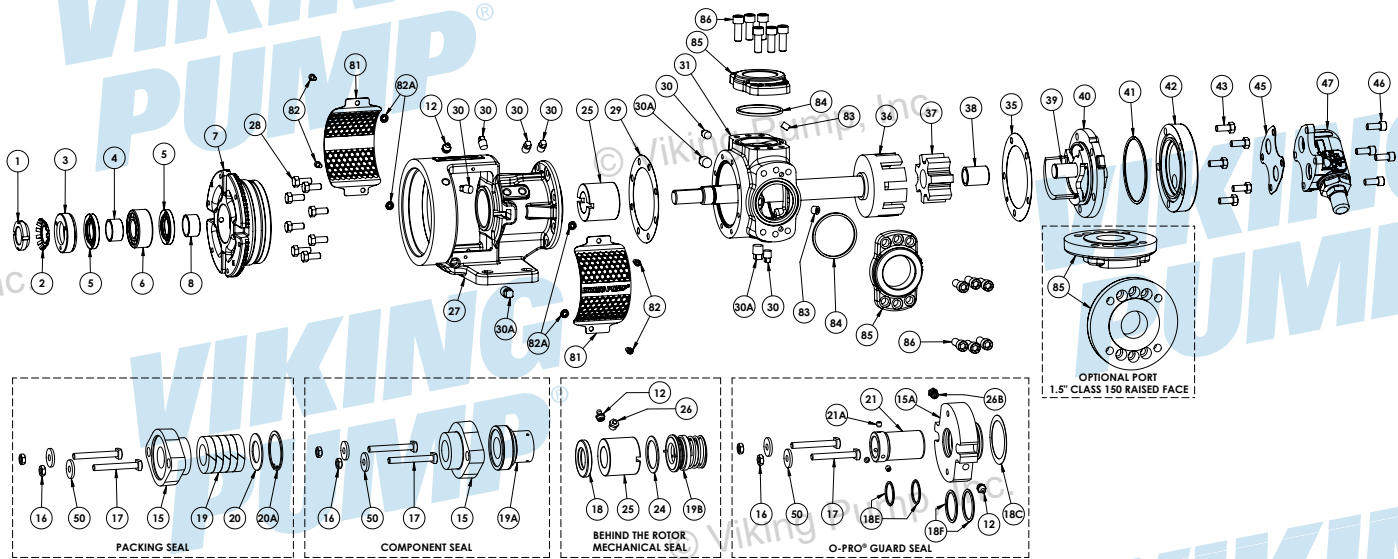

Item	Name Of Part	Item	Name Of Part	Item	Name Of Part
1	Locknut	19A	Component Mechanical Seal	37	Idler and Bushing Assembly
2	Lockwasher	19B	Behind the Rotor Seal	38	Idler Bushing
3	End Cap for Bearing Housing	20	Packing Retaining Washer	39	Idler Pin
4	Bearing Spacer Collar (Outer)	20A	Internal Retaining Ring	40	Head and Idler Pin Assembly
5	Lip Seal for Bearing Housing	21	Set Collar or O-Pro® Guard Sleeve	41	O-Ring for Jacket Head Plate
6	Ball Bearing	21A	O-Pro® Guard Setscrews (Qty 3 Req'd)	42	Jacket Head Plate
7	Bearing Housing	24	Seal Spacer	43	Head Capscrews (Qty 5 Req'd)
8	Bearing Spacer Collar (Inner)	25	Bracket Bushing	45	Relief Valve Gasket (Qty 1 Req'd)
12	Grease Fitting, 1/8" NPT	26	Pressure Relief Fitting, 1/8" NPT, 25 PSI	46	Capscrews for Valve (Qty 4 Req'd)
15	Packing Gland / Seal Holder	26B	Pressure Relief Fitting, 1/8" NPT, 80-140 PSI	47	Relief Valve
15A	O-Pro® Guard Gland	27	Bracket and Bushing Assembly	50	Seal Washers (Qty 2 Req'd)
16	Seal Nuts (Qty 2 Req'd)	28	Bracket Capscrews (Qty 8 Req'd)	81	Window Guards (Qty 2 Req'd)
17	Seal Capscrews (Qty 2 Req'd)	29	Bracket Gasket or O-Ring	82	Window Guard Capscrews (Qty 4 Req'd)
18	Lip Seal	30	Pipe Plug, 1/8" NPT (Qty 6 Req'd)	82A	Retaining Washers (Qty 4 Req'd)
18C	Outer Gasket - O-Pro® Guard (Qty 1)	30A	Pipe Plug, 1/4" NPT (Qty 3 Req'd)	83	Pipe Plug, 1/8" NPT, Hex Socket (Qty 2 Req'd)
18E	Inner Static O-Ring - O-Pro® Guard (Qty 2)	31	Casing	84	Casing Port O-Rings or Gaskets (Qty 2 Req'd)
18F	Dynamic O-Ring - O-Pro® Guard (Qty 2)	35	Head Gasket or O-Ring	85	Bolt-on-Ports (Qty 2 Req'd)
19	Packing (Qty 5)	36	Rotor and Shaft Assembly	86	Bolt-on-Port Capscrews (Qty 12 Req'd)

**FIGURE 7: EXPLODED VIEW (K, KK, L, LL, LS SIZES) — IMAGE IS REPRESENTATIVE ONLY**  
**127C SERIES™, 1127C SERIES™, 4127C SERIES™, 227C SERIES™, 1227C SERIES™, 4227C SERIES™**

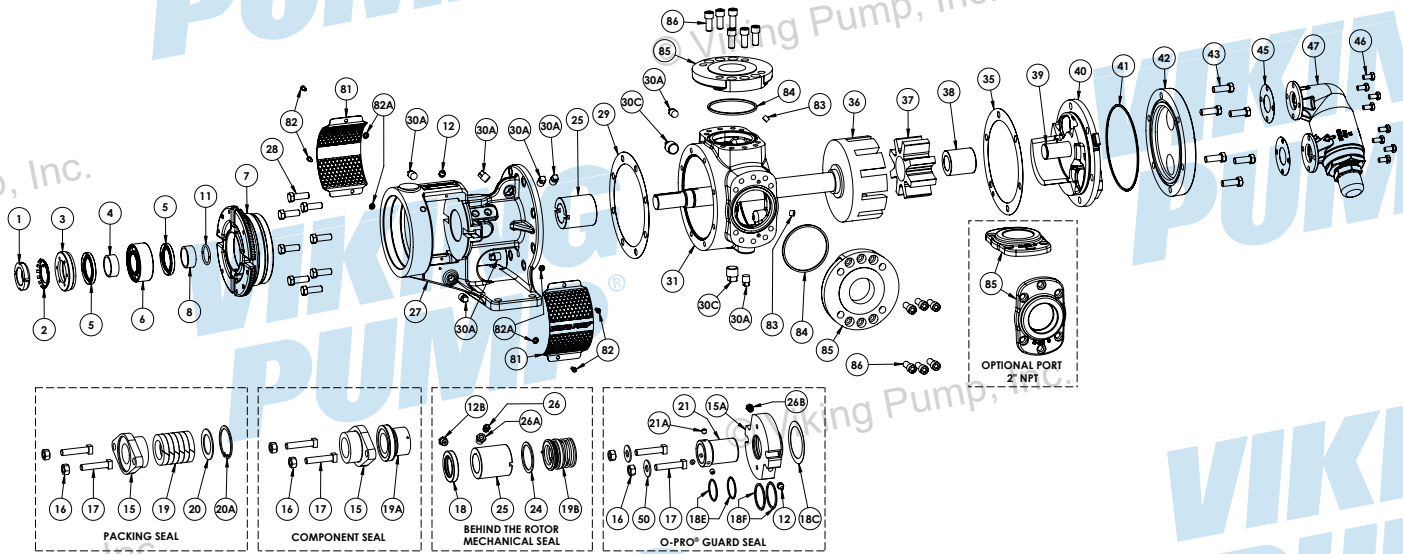

Item	Name Of Part	Item	Name Of Part	Item	Name Of Part
1	Locknut	19	Packing (Qty 6)	36	Rotor and Shaft Assembly
2	Lockwasher	19A	Component Mechanical Seal	37	Idler and Bushing Assembly
3	End Cap for Bearing Housing	19B	Behind the Rotor Seal	38	Idler Bushing
4	Bearing Spacer Collar (Outer)	20	Packing Retaining Washer	39	Idler Pin
5	Lip Seal for Bearing Housing	20A	Internal Retaining Ring	40	Head and Idler Pin Assembly
6	Ball Bearing	21	Set Collar or O-Pro® Guard Sleeve	41	O-Ring for Jacket Head Plate
7	Bearing Housing	21A	O-Pro® Guard Setscrews (Qty 3 Req'd)	42	Jacket Head Plate
8	Bearing Spacer Collar (Inner)	24	Seal Spacer	43	Head Capscrews (Qty 6 Req'd)
11	Ring, Half Round (Qty 2 Req'd)	25	Bracket Bushing	45	Relief Valve Gasket (Qty 2 Req'd)
12	Grease Fitting, 1/8" NPT	26	Pressure Relief Fitting 1/8" NPT, 25 PSI	46	Capscrews for Valve (Qty 8 Req'd)
12B	Grease Fitting, 1/4" NPT	26A	Reducer Fitting, 1/4" NPT to 1/8" NPT	47	Relief Valve
15	Packing Gland / Seal Holder	26B	Pressure Relief Fitting 1/8" NPT, 80-140 PSI	50	Seal Washers (Qty 2 Req'd)
15A	O-Pro® Guard Gland	27	Bracket and Bushing Assembly	81	Window Guards (Qty 2 Req'd)
16	Seal Nuts (Qty 2 Req'd)	28	Bracket Capscrews (Qty 8 Req'd)	82	Window Guard Capscrews (Qty 4 Req'd)
17	Seal Capscrews (Qty 2 Req'd)	29	Bracket Gasket or O-Ring	82A	Retaining Washers (Qty 4 Req'd)
18	Lip Seal	30A	Pipe Plug, 1/4" NPT (Qty 7 or 8 Req'd)	83	Pipe Plug, 1/8" NPT, Hex Socket (Qty 2 Req'd)
18C	Outer Gasket - O-Pro® Guard	30C	Pipe Plug, 1/2" NPT (Qty 2 Req'd)	84	Casing Port O-Rings or Gaskets (Qty 2 Req'd)
18E	Inner Static O-Ring - O-Pro® Guard (Qty 2)	31	Casing	85	Bolt-on-Ports (Qty 2 Req'd)
18F	Dynamic O-Ring - O-Pro® Guard (Qty 2)	35	Head Gasket or O-Ring	86	Bolt-on-Port Capscrews (Qty 12 Req'd)

**FIGURE 8: EXPLODED VIEW (Q,QS SIZES) — IMAGE IS REPRESENTATIVE ONLY**  
**127C SERIES™, 1127C SERIES™, 4127C SERIES™, 227C SERIES™, 1227C SERIES™, 4227C SERIES™**

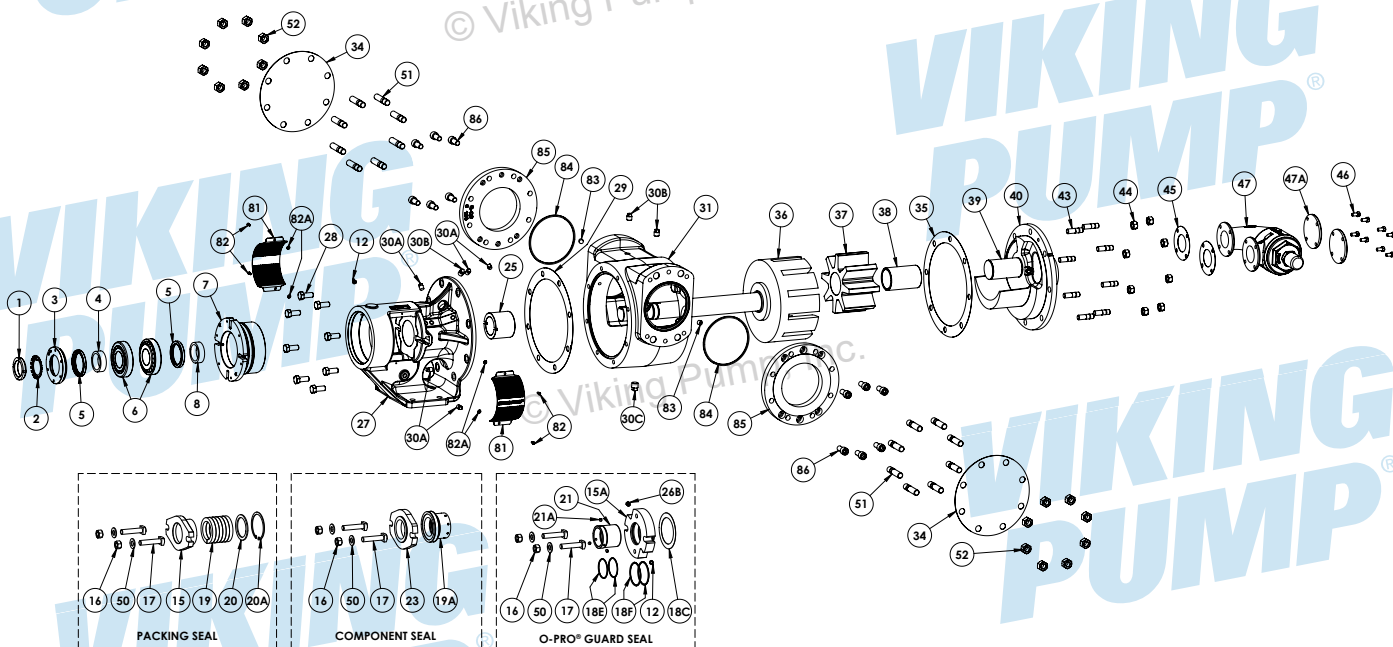

Item	Name Of Part	Item	Name Of Part	Item	Name Of Part
1	Locknut	20A	Internal Retaining Ring	40	Head and Idler Pin Assembly
2	Lockwasher	21	O-Pro® Guard Sleeve	43	Head Studs (Qty 8 Req'd)
3	End Cap for Bearing Housing	21A	O-Pro® Guard Setscrews (Qty 3 Req'd)	44	Head Stud Nuts (Qty 8 Req'd)
4	Bearing Spacer Collar (Outer)	23	Seal Holder Plate	45	Relief Valve Gaskets (Qty 2 Req'd)
5	Lip Seal for Bearing Housing	25	Bracket Bushing	46	Capscrews for Valve (Qty 8 Req'd)
6	Ball Bearing (Qty 2 Req'd)	26B	Pressure Relief Fitting, 1/8" NPT, 80-140 PSI	47	Relief Valve
7	Bearing Housing	27	Bracket and Bushing Assembly	47A	Cover Plates (For Plain Head Pump) (Qty 2)
8	Bearing Spacer Collar (Inner)	28	Bracket Capscrews (Qty 8 Req'd)	50	Seal Washers (Qty 2 Req'd)
12	Grease Fitting, 1/8" NPT	29	Bracket Gasket or O-Ring	51	Studs for Flanges (Qty 16 Req'd)
15	Packing Gland / Seal Holder	30A	Pipe Plug, 1/4" NPT (Qty 4 or 5 Req'd)	52	Nuts for Flanges (Qty 16 Req'd)
15A	O-Pro® Guard Gland	30B	Pipe Plug, 3/8" NPT (Qty 3 Req'd)	81	Window Guards (Qty 2 Req'd)
16	Seal Nuts (Qty 2 Req'd)	30C	Pipe Plug, 1/2" NPT (Qty 1 Req'd)	82	Window Guard Capscrews (Qty 4 Req'd)
17	Seal Capscrews (Qty 2 Req'd)	31	Casing	82A	Retaining Washers (Qty 4 Req'd)
18C	Outer Gasket - O-Pro® Guard	34	Pipe Flange Gaskets (Qty 2 Req'd)	83	Pipe Plug, 1/4" NPT, Hex Socket (Qty 2 Req'd)
18E	Inner Static O-Ring - O-Pro® Guard (Qty 2)	35	Head Gasket or O-Ring	84	Casing Port O-Rings or Gaskets (Qty 2 Req'd)
18F	Dynamic O-Ring - O-Pro® Guard (Qty 2)	36	Rotor and Shaft Assembly	85	Bolt-on-Ports (Qty 2 Req'd)
19	Packing (Qty 6)	37	Idler and Bushing Assembly	86	Bolt-on-Port Capscrews (Qty 12 Req'd)
19A	Component Mechanical Seal	38	Idler Bushing		
20	Packing Retaining Washer	39	Idler Pin		

## **⚠ DANGER !**

Before opening any Viking pump liquid chamber (pumping chamber, reservoir, relief valve adjusting cap fitting, etc.) be sure:

1. That any pressure in the chamber has been completely vented through the suction or discharge lines, or other appropriate openings or connections.
2. That the driving means (motor, turbine, engine, etc.) has been "locked out" or made non-operational, so that it cannot be started while work is being done on pump.
3. That you know what liquid the pump has been handling and the precautions necessary to safely handle the liquid. Obtain a material safety data sheet (MSDS) for the liquid to be sure these precautions are understood.

Failure to follow above listed precautionary measures may result in serious injury or death.

## **REMOVAL: CARTRIDGE MECHANICAL SEAL**

Cartridge mechanical seals are designed so that they may be replaced with minimal pump and piping disassembly

1. Insert brass or plastic bar through port opening between rotor teeth to keep shaft from turning. Bend up tang of lockwasher and with a spanner wrench, remove locknut and lockwasher from shaft.
2. Loosen two set screws in the face of the bearing housing and remove the bearing housing assembly from the bracket.
3. Remove the pair of half round rings (K, KK, L, LL, LS sizes only) under the inner spacer collar from the shaft.
4. Remove any flush or barrier fluid tubes connected to the seal gland.
5. Replace or turn centering clips to original position.
6. Loosen setscrews on the seal collar to free the cartridge seal from the shaft.
7. Loosen and remove the two nuts holding the seal to the pump and slide the cartridge seal out through the bearing housing opening.

If the pump is to be disassembled further, refer to "Pump Disassembly" on page 11.

## **INSTALLATION: CARTRIDGE MECHANICAL SEAL**

1. **NOTE:** Burrs left on shaft can damage O-ring on seal sleeve during installation. Inspect shaft for burrs and remove any found with a fine grade of emery cloth.
2. Clean rotor shaft and face of seal chamber.
3. Place tapered installation sleeve on shaft. Coat rotor shaft, tapered installation sleeve, and O-ring in the inside diameter of cartridge seal sleeve with a generous amount of P-80® or equivalent. See "Figure 9" on page 7.
4. Slide cartridge seal over installation sleeve on shaft until it contacts the seal chamber face. Remove tapered installation sleeve from shaft.
5. Place pair of half round rings in groove on shaft (K, KK, L, LL, LS sizes only) and turn bearing housing assembly into bracket.
6. Put lockwasher and locknut on shaft. Tighten locknut and bend one tang of lockwasher into slot of locknut. See "Table 3" on page 13.
7. Adjust pump end clearance, refer to "Thrust Bearing Adjustment" on page 14.
8. Insert gland capscrews and secure gland to bracket face using washers and nuts.  
**NOTE:** turn shaft several turns while gland is loose to center seal; then tighten nuts enough to compress gland gasket. Tighten only enough to contain leakage and not to distort gland.
9. Tighten setscrews on seal drive collar to shaft. Remove or turn centering clips out of the way so as to clear the drive collar.
10. Turn shaft by hand or jog motor to check drive collar for runout.
11. Connect circulation line or vent stuffing box seals without circulation line until liquid is present on start up.  
**NOTE:** For maximum seal life, circulation line should be used.

## **⚠ DANGER !**

Before starting pump, be sure all drive equipment guards are in place.

Failure to properly mount guards may result in serious injury or death.

**FIGURE 9**



**NOTE:** Coat rotor shaft, tapered installation sleeve and inner diameter of mechanical seal with P-80® or equivalent before assembly.

P-80® is a registered trademark of International Products Corporation

## DANGER !

Before opening any Viking pump liquid chamber (pumping chamber, reservoir, relief valve adjusting cap fitting, etc.) be sure:

1. That any pressure in the chamber has been completely vented through the suction or discharge lines, or other appropriate openings or connections.
2. That the driving means (motor, turbine, engine, etc.) has been "locked out" or made non-operational, so that it cannot be started while work is being done on pump.
3. That you know what liquid the pump has been handling and the precautions necessary to safely handle the liquid. Obtain a material safety data sheet (MSDS) for the liquid to be sure these precautions are understood.

Failure to follow above listed precautionary measures may result in serious injury or death.

## REMOVAL: COMPONENT MECHANICAL SEAL

Elastomeric bellows, elastomeric o-ring and PTFE wedge seals generally require pump disassembly to be replaced (refer to "Pump Disassembly" on page 11).

1. Insert brass or plastic bar through port opening between rotor teeth to keep shaft from turning. Bend up tang of lockwasher and with a spanner wrench, remove locknut and lockwasher from shaft.
2. Loosen two set screws in the face of the bearing housing and remove the bearing housing assembly from the bracket.
3. Remove the pair of half round rings (K, KK, L, LL, LS sizes only) under the inner spacer collar from the shaft.
4. Loosen nuts and remove seal holder, seal seat and seal gasket(s).
5. Loosen setscrews in mechanical seal rotary member.

**NOTE:** Circulation line and/or plugs will need to be removed to access setscrews.

*If changing the mechanical seal is the extent of the maintenance to be performed, then the rotor shaft assembly only needs to be moved far enough to dislodge the rotary member of the seal.*

6. Drive the rotor/shaft assembly out of the casing until the rotor teeth extend past the face of the casing.
7. Push the rotor/shaft assembly back into the casing. The rotary member of the seal should now be pushed far enough down the shaft for easy removal.

## INSTALLATION: COMPONENT MECHANICAL SEAL

1. Clean rotor shaft and seal housing bore. Make sure they are free of dirt, grit and scratches. Gently radius leading edge of the shaft diameter over which seal is to be placed. Never touch mechanical seal faces with anything except clean hands or clean cloth. Minute particles can scratch the seal faces and cause leakage.
2. Place tapered installation sleeve on the shaft. Coat tapered sleeve and inside of the rotary member with a generous quantity of P-80® or equivalent. Grease is not recommended. Start rotary member on shaft and over tapered sleeve. See "Figure 10" on page 8.
3. Move rotary member so setscrews are directly below seal access holes on side of bracket. Tighten all setscrews securely to shaft. Some seals are equipped with holding clips which compress the seal springs. Remove holding clips to release springs after seal is installed on shaft.
4. **FOR "O-RING" GASKET TYPE MECHANICAL SEAL SEAT:** Lubricate outer diameter of O-Ring seal gasket with P-80® or equivalent. Press seal seat in to bore until back, unlapped face, is flush with bore. Install seal holder, capscrews, and nuts and tighten securely. Remove tapered installation sleeve.

### FOR "CLAMPED-IN" TYPE MECHANICAL SEAL SEAT:

Flush sealing faces of both rotary member and seal seat with oil and install seal seat and seat gasket over end of shaft against machined bracket face. Install other seal gasket, seal holder, capscrews, and nuts and tighten securely. Remove tapered installation sleeve.

5. Connect suckback or flush line or vent stuffing box for seals without circulation line until liquid is present on start up.

**NOTE:** For maximum seal life, suckback or flush line should be used.

## DANGER !

Before starting pump, be sure all drive equipment guards are in place.

Failure to properly mount guards may result in serious injury or death.

FIGURE 10

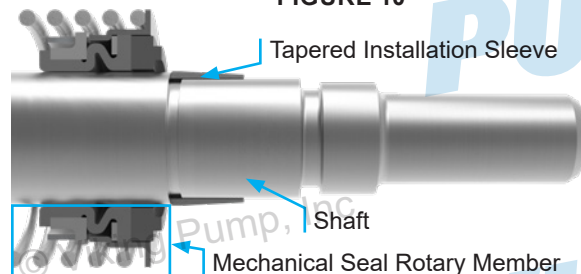

**NOTE:** Coat rotor shaft, tapered installation sleeve and inner diameter of mechanical seal with P-80® or equivalent before assembly.

P-80® is a registered trademark of International Products Corporation



## ⚠ DANGER !

Before opening any Viking pump liquid chamber (pumping chamber, reservoir, relief valve adjusting cap fitting, etc.) be sure:

1. That any pressure in the chamber has been completely vented through the suction or discharge lines, or other appropriate openings or connections.
2. That the driving means (motor, turbine, engine, etc.) has been "locked out" or made non-operational, so that it cannot be started while work is being done on pump.
3. That you know what liquid the pump has been handling and the precautions necessary to safely handle the liquid. Obtain a material safety data sheet (MSDS) for the liquid to be sure these precautions are understood.

Failure to follow above listed precautionary measures may result in serious injury or death.

## REMOVAL: BEHIND THE ROTOR MECHANICAL SEAL

Elastomeric bellows, elastomeric o-ring and PTFE wedge seals require pump disassembly to be replaced (refer to "Pump Disassembly" on page 11).

1. Insert brass or plastic bar through port opening between rotor teeth to keep shaft from turning. Bend up tang of lockwasher and with a spanner wrench, remove locknut and lockwasher from the shaft.
2. Loosen two set screws in the face of the bearing housing and remove the bearing housing assembly from the bracket.
3. Remove the pair of half round rings (K, KK, L, LL, LS sizes only) under the inner spacer collar from the shaft.
4. Remove the rotor/shaft assembly completely from the pump. Remove lip seal from bracket.
5. Insert a screwdriver or similar tool through the bearing-housing end of the bracket bore until contact is made with the stationary face of the seal. Use a mallet to carefully tap the screwdriver to slide the stationary face away from the bushing. Use caution to avoid damaging bushing during removal. Remove the rotary member of the mechanical seal from the rotor shaft. Remove spacer washer from bracket bore. **Note:** Some sizes/types of stationary faces may also be removed by inserting packing hooks into the gap of the notched bushing and pulling carefully.

FIGURE 11

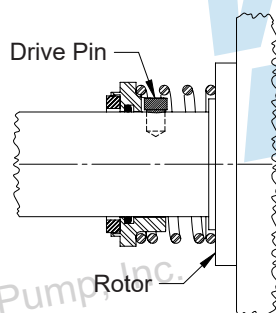

## INSTALLATION: BEHIND THE ROTOR MECHANICAL SEAL

1. Clean rotor shaft, rear of rotor, seal housing bore, and spacer washer. Make sure they are free of dirt, grit and scratches. Gently radius leading edge of the shaft diameter over which the seal is to be placed.  
Never touch mechanical seal faces with anything except clean hands or clean cloth. Minute particles can scratch the seal faces and cause leakage.
2. Place tapered installation sleeve on the shaft (H, HL, K, KK, Q, QS sizes only). Coat tapered sleeve and inside of the rotary member with a generous quantity of P-80 or equivalent. Grease is not recommended. Start rotary member on shaft and over tapered sleeve. See "Figure 10" on page 8.
3. If the seal uses setscrews to secure the seal to the shaft, tighten the setscrews once the seal is in place. Move the rotary member all the way on the rotor shaft until it is against the rotor hub.

If the seal uses a single spring and drive pin, place seal spring on shaft against rotor hub (see "Figure 11" on page 9). Slide rotary member, lapped contact surface facing away from spring, over seal installation sleeve on shaft until it is against spring. Slot in the seal must line up with the drive pin in the shaft. Do not compress the spring.

Some PTFE seals are equipped with holding clips which compress the seal springs. Remove the holding clips to release the springs after the seal is installed on shaft.

4. If converting pump to behind the rotor seal, see "Bracket Bushing Installation: Behind the Rotor Seal" on page 15 for more information. Install spacer washer into the bracket bore flush with end of bushing. Lubricate outer diameter of seal seat gasket with oil. Press seal seat into bore until the back, unlapped face bottoms against bracket bushing. Make sure the seat anti-rotation pins are aligned with slots in the bracket bushing. See "Figure 12" on page 9.
5. After reinstalling rotor and shaft assembly and pump head, lubricate and install lip seal in stuffing box with lip facing casing side of the pump, flush with the outer surface. See "Figure 12" on page 9.
6. Ensure grease fitting and appropriate pressure relief fitting are installed in stuffing box access holes. Slowly fill stuffing box with appropriate grease, while turning shaft, until pressure relief fitting ejects grease.
7. Install bearing assembly and set end clearance (refer to "Pump Assembly" on page 13).

FIGURE 12

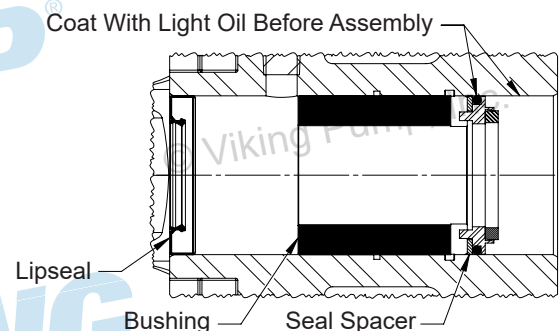
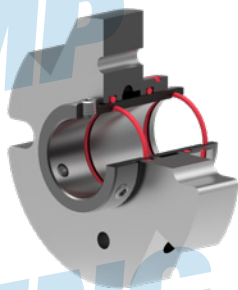

FIGURE 13



## REMOVAL: O-PRO® GUARD SEAL

The O-Pro® Guard seals (See "Figure 13" on page 10) are designed so that they may be replaced with minimal pump and piping disassembly.

1. Insert length of hardwood, plastic or brass through port opening between rotor teeth to keep shaft from turning. Bend up tang of lockwasher and with a spanner wrench, remove locknut and lockwasher from shaft.
2. Loosen two set screws in the face of the bearing housing and remove the bearing housing assembly from the bracket.
3. Remove the pair of half round rings (KK, L, LL, and LS sizes only) under the inner spacer collar from the shaft.
4. Loosen set screws (3) on the seal sleeve to free the sleeve from the shaft.
5. Loosen and remove the two nuts holding the seal gland to the pump and slide the O-Pro® Guard seal out through the bearing housing opening.
6. There are tapped holes at the 6 and 12 o'clock position on the face of the O-Pro® Guard gland. Jack bolts can be threaded into these holes to assist with removing the seal from the seal chamber if required, see "Figure 14" on page 10.

If the pump is to be disassembled further, refer to "Pump Disassembly" on page 11.

FIGURE 14: JACK BOLT SIZES

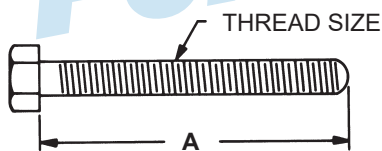

Pump Size	A (Inch)	Thread Size (Inch)
H, HL, K, KK, L, LL, LS	2.50	3/8 - 11 NC
Q, QS	1.75	5/8 - 11 NC

## INSTALLATION: O-PRO® GUARD SEAL

1. Install (3) set screws in sleeve.
2. Slide installation sleeve onto the shaft and flush against the shoulder
3. Install 2 internal o-rings in sleeve. Install (1) external o-ring and (2) internal o-rings in seal gland. Lubricate all o-rings and installation sleeve to ease installation.
4. Install gland sleeve into gland to create "Sleeve and Gland Assembly". The setscrews of the sleeve must be on the opposite side of the single external O-ring of the gland.  
**NOTE:** Burrs left on shaft can damage the inner dynamic o-rings in the sleeve during installation. Inspect the shaft for burrs and remove any found with a fine grade of emery cloth.
5. Install "Sleeve and Gland Assembly" through the bearing housing opening, onto the shaft. The gland side with the single external O-ring must be installed onto the shaft first. Be careful to not cut the gland sleeve's internal o-rings when installing seal onto the shaft.
6. Install the seal gland flush against the mounting face of the pump bracket. Remove installation sleeve from the shaft.
7. Install bearing housing assemble and adjust end clearance, refer to "Thrust Bearing Adjustment" on page 14.
8. Install (2) bolts, (2) washers, and (2) nuts and tighten to secure seal gland to the pump bracket.
9. Make sure (3) set screws are installed in sleeve. Position sleeve so the face of the gland is flush with the edge of the groove in the sleeve. Tighten (3) set screws on sleeve evenly to ensure the sleeve is concentric with the shaft. Install grease fitting into the lowest hole in gland. Contact your Viking Pump® representative to obtain seal installation drawings for additional information on grease fitting and set screw locations.
10. Add grease through the grease fitting in seal gland while rotating the pump shaft.
11. Fill until grease comes out of the open hole in the gland where the pressure relief fitting will go.
12. Install pressure relief fitting in the gland, apply additional grease to ensure all air pockets have been evacuated from the area and grease has exited the relief fitting.

### DANGER !

Before starting pump, be sure all drive equipment guards are in place.

Failure to properly mount guards may result in serious injury or death.

## ⚠ DANGER!

Before opening any Viking pump liquid chamber (pumping chamber, reservoir, relief valve adjusting cap fitting, etc.) be sure:

1. That any pressure in the chamber has been completely vented through the suction or discharge lines, or other appropriate openings or connections.
2. That the driving means (motor, turbine, engine, etc.) has been "locked out" or made non-operational, so that it cannot be started while work is being done on pump.
3. That you know what liquid the pump has been handling and the precautions necessary to safely handle the liquid. Obtain a material safety data sheet (MSDS) for the liquid to be sure these precautions are understood.

Failure to follow above listed precautionary measures may result in serious injury or death.

## REMOVAL: PACKING

1. Insert length of hardwood, plastic or brass through port opening between rotor teeth or lock coupling end of shaft to keep shaft from turning. Bend up tang of lockwasher and with a spanner wrench; remove locknut and lockwasher from shaft. Remove brass or plastic bar from port opening.
2. Loosen the two setscrews in the face of the bearing housing and remove the bearing housing assembly from the bracket. See "Figure 17" on page 12, "Figure 18" on page 12 or "Figure 19" on page 12.
3. **K, KK, L, LL, LS Sizes ONLY:** Remove pair of half round rings under the inner spacer collar from the shaft.
4. Remove pipe plug from drain hole in casing or bracket, breaking vacuum behind rotor.
5. Remove packing gland nuts. Slide packing gland out of stuffing box, and remove packing, packing retaining washer and internal retaining ring.

**NOTE:** Contact your Viking Pump® representative for Engineering Standard ES-9 on packing information & options.

## INSTALLATION: PACKING

**NOTE:** When assembling packed pump, use packing suitable for liquid being pumped.

1. Install internal retaining ring into groove in pump bore. See "Figure 15" on page 11.
2. Install packing washer against retaining ring.
3. Install packing, staggering the joints from one side of the shaft to the other. Seat each ring with a short length of pipe or similar tool to ensure each ring is seated. Lubricate packing rings with oil, grease or graphite to aid assembly.
4. Install packing gland, capscrews/studs, washers and nuts. Make sure the gland is installed square and nuts are tightened evenly. Tighten nuts until packing gland is snug against packing. **DO NOT OVER-TIGHTEN!**

**TABLE 1: PACKING RING CHART**

Pump Size	Number of Packing Rings
H, HL	5
K, KK, L, LL, LS, Q, QS	6

**FIGURE 15: RETAINING RING GROOVE WITH PACKING**

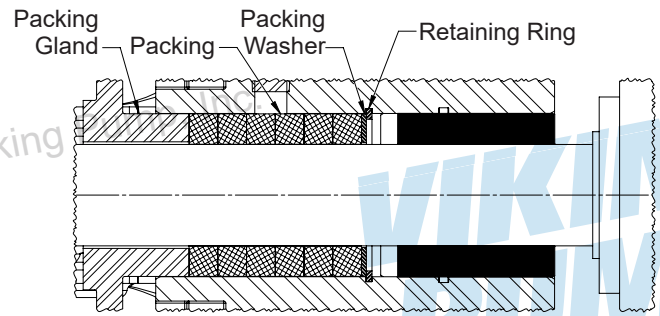

## PUMP DISASSEMBLY

1. Mark head and casing before disassembly to ensure proper reassembly. The idler pin, which is offset in pump head, must be positioned toward and equal distance between port connections to allow for proper flow of liquid through the pump.

Remove nuts and capscrews from head. Jack bolts should be used with Q, QS size pumps to back head away from casing. Proper size and length of jack bolts for pump size are shown in "Figure 16" on page 11. The use of a hoist to support head will facilitate its removal.

**FIGURE 16: MINIMUM LENGTH OF JACK BOLTS**

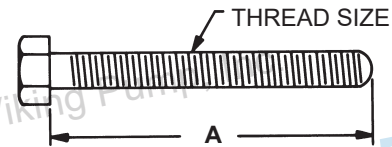

Pump Size	No. Screws Used	A	Thread Size (Inch)
Q, QS	2	4.00	0.50" - 13 NC

Ⓢ Avoid damaging head gasket. Back head slightly away from casing. Do not allow idler to fall from idler pin. To prevent this, tilt top of head back when removing. Remove head from pump.

If pump is furnished with pressure relief valve, it need not be removed from head or disassembled at this point; however, removing relief valve will lessen total weight of part. Do not use chain or cable around relief valve body to support head during removal. Refer to "Pressure Relief Valve Instructions" on page 16.

If pump has jacketed head plate, it will separate from head when it is removed. The gasket between head and jacket head plate must be totally removed. Use new gasket when assembling pump.

2. Remove head gasket, idler and bushing assembly.
3. Carefully remove rotor and shaft to avoid damaging bracket bushing.
4. Loosen two radial setscrews in flange of bearing housing and with a spanner wrench remove the outer end cap with lipseal and outer bearing spacer collar.
5. Remove the double row ball bearing, (2 tapered roller bearings on Q, QS sizes), lipseal and inner bearing spacer collar from the bearing housing.

6. Clean all parts thoroughly and examine for wear and damage. Check lipseals, bearings, bushings, and idler pin and replace if necessary. Check all other parts for nicks, burrs, excessive wear and replace if necessary. Wash bearings in clean solvent. Blow out bearings with compressed air. Do not allow bearings to spin; turn them slowly by hand. Spinning bearings will damage bearing components. Make sure bearings are clean, then lubricate with light oil and check for roughness. Roughness can be determined by turning outer race by hand.

**CAUTION !**

Do not intermix inner and outer races of tapered roller bearing (Q, QS sizes)

7. Casing can be checked for wear or damage while mounted on bracket.
8. Inspect bracket bushing for wear and remove if damaged or worn.

**FIGURE 17: BEARING HOUSING ASSEMBLY (H, HL)**

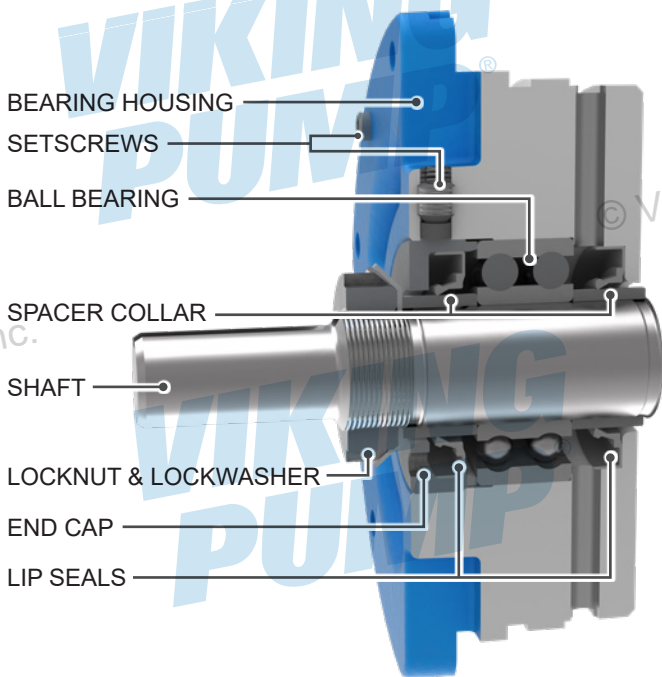

**FIGURE 18: BEARING HOUSING ASSEMBLY (K, KK, L, LL, LS)**

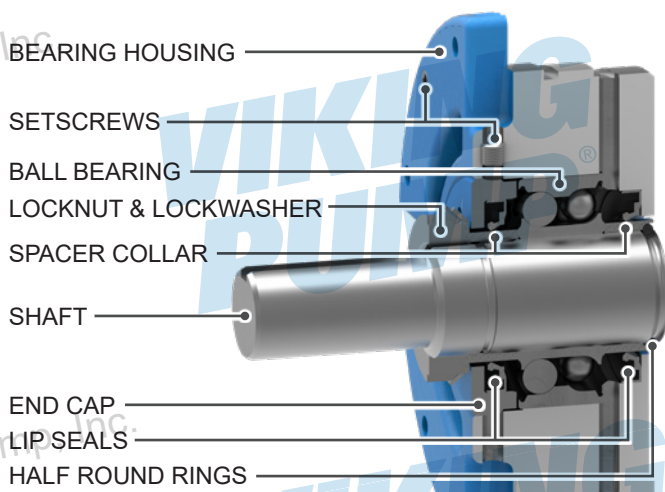

**FIGURE 19: BEARING HOUSING ASSEMBLY (Q, QS)**

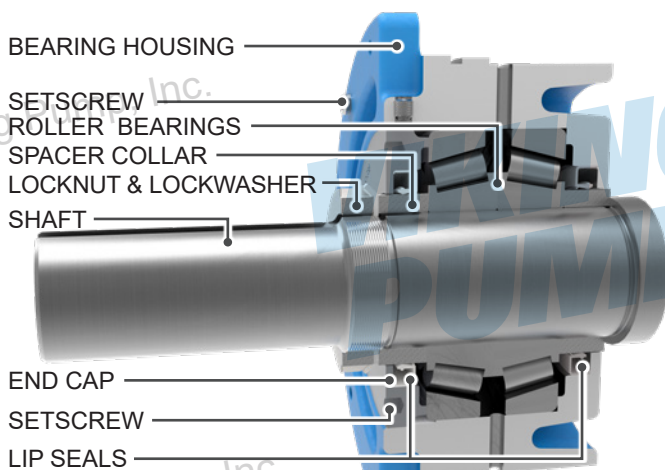

# PUMP ASSEMBLY

1. Install Bracket Bushing if removed due to wear. The bushing can be installed in one of two locations depending on the seal configuration of the pump. For Behind the rotor seals refer to **"Bracket Bushing Installation: Behind the Rotor Seal"** on page 15. For all other seal types refer to **"Bracket Bushing Installation: Stuffing Box Seals"** on page 15. If installing a carbon graphite bushing refer to **"Installation: Carbon Graphite Bushings"** on page 15.
2. Install the casing on the bracket and bushing assembly if separated during disassembly. Be sure gasket is placed between bracket and casing or O-Ring is installed in groove on casing.
3. Coat shaft of rotor / shaft assembly with light oil. Start end of shaft in bracket bushing turning from right to left, slowly pushing rotor in casing.
4. Coat idler pin with light oil and place idler and bushing on idler pin in head. If replacing with carbon graphite bushing, Refer to **"Installation: Carbon Graphite Bushings"** on page 15.
5. Using a .010 to .015 thick head gasket or O-Ring in O-Ring groove, install head and idler assembly on pump. Pump head and casing should have been marked before disassembly to ensure proper reassembly. If not, be sure idler pin, which is offset in pump head, is positioned toward the equal distance between port connections to allow for proper flow of liquid through pump. If pump is equipped with jacketed headplate, install at this time along with a new gasket.

Tighten head capscrews evenly.

See **"Figure 17"** on page 12, **"Figure 18"** on page 12 or **"Figure 19"** on page 12 for bearing housing assembly.

6. Install the lipseal in the bearing housing (See **"Figure 17"** on page 12, **"Figure 18"** on page 12 or **"Figure 19"** on page 12 for lip orientation).
7. **H, HL, K, KK, L, LL, LS Sizes:** Pack the ball bearing with grease and push or press the bearing into the bearing housing. See **"Figure 17"** on page 12 or **"Figure 18"** on page 12.
- Q, QS Sizes:** Pack tapered roller bearings with grease and press or push bearings into housing with large end of inner races together. It is possible to install bearings incorrectly. For proper assembly see **"Figure 19"** on page 12.
8. Install the lipseal in the end cap (see appropriate figure for lip orientation). Thread the end cap into the bearing housing along with outer bearing spacer collar and tighten against the bearing.

**Q, QS Sizes ONLY:** Tapered roller bearings require preload to operate properly. To set preload tighten end cap so that inner races of bearings cannot be rotated by hand. Make a mark on the outside diameter of the bearing housing and a corresponding mark on the bearing housing end cap. Rotate the bearing housing end cap in a counter clockwise direction until the mark on the outside diameter of the bearing housing is past the mark on the bearing housing end cap by the amount specified in **"Table 2"** on page 13. This will provide the correct end play for the bearings.

Lock end cap in place with two setscrews in the flange of the bearing housing.

**TABLE 2: END CAP ADJUSTMENT**

Pump Size	Inches (mm)
Q, QS	0.270 in. (6.86 mm)

**NOTE:** Refer to **"Installation: Cartridge Mechanical Seal"** on page 7, **"Installation: Component Mechanical Seal"** on page 8, **"Installation: O-Pro® Guard Seal"** on page 10 **"Installation: Behind the Rotor Mechanical Seal"** on page 9 or **"Installation: Packing"** on page 11 depending on sealing method of the pump.

9. Slide inner spacer collar over shaft with recessed end facing rotor. H, HL, Q, QS bearing spacer collars are not recessed.

**K, KK, L, LL, LS Sizes ONLY:** Place pair of half round rings on shaft and slide inner bearing spacer collar over half round rings to lock them in place.

10. Thread the bearing housing with lipseals; end cap, outer bearing spacer collar and bearings installed into bracket.
11. Put lockwasher and locknut on shaft. Insert brass or plastic bar through port opening between rotor teeth to keep shaft from turning. Tighten locknut as per **"Table 3"** on page 13. If tang does not line up with slot, tighten locknut until it does. Failure to tighten locknut or engage lockwasher tang could result in early bearing failure and cause damage to rest of pump. Remove brass or plastic bar from port opening.

**TABLE 3: LOCKNUT TORQUE**

Pump Size	Torque (Ft.-Lbs.)
H, HL	50-70
K, KK, L, LL, LS, Q, QS	90-110

12. Adjust pump end clearance, refer to **"Thrust Bearing Adjustment"** on page 14.
13. Install pump flanges if removed during disassembly, refer to **"Pump Flange Assembly"** on page 14.
14. Reinstall drain plugs and circulation plugs (as needed) in casing, as well as drain plugs in the bracket.
15. Lubricate all grease fittings with multi-purpose grease, NLGI #2. The factory uses polyurea type grease. Thoroughly clean out grease if using another grease chemistry. See Engineering Service Bulletin ESB-515 at the end of Appendix for Viking standard grease types to check compatibility

## DANGER !

**Before starting pump, be sure all drive equipment guards are in place.**

**Failure to properly mount guards may result in serious injury or death.**

# PUMP FLANGE ASSEMBLY

## ⚠ WARNING !

When installing pump flanges, be sure to follow torque specifications and instruction order below. Failure to properly mount flanges may result in serious injury or death.

Before installing port flanges, ensure the sealing glands near the casing ports are clean and free of debris.

1. Install square-gasket or O-ring into groove on casing. For best seal, lubricate O-rings before installation, or, if using a square gasket, use gasket sealant.®

2. Align chosen flange with port on casing.

**NOTE: Not all threaded holes in casing are used for every flange.**

3. Install screws until finger tight initially.

4. Confirm required capscrew torque from "Table 4" on page 14.

5. Tighten the bolts using a star bolting pattern, With torque limiting device set to final capscrew torque. See "Figure 20" on page 14.

6. Once complete retorquer all capscrews 100% while moving clockwise in a circular pattern. See "Figure 21" on page 14.

TABLE 4: 18-8 STAINLESS STEEL CAPSCREWS

Pump size	Capscrew		Torque Ft-lb (Nm)		
	Size	Length	Dry	Lubricated	Anti-Seize
H, HL	3/8-16	1.00	17-18 (23.0-24.4)	12-13 (16.3-17.6)	9-10 (12.2-13.6)
K, KK	7/16-14	1.00	27-29 (36.6-39.3)	19-21 (25.8-28.5)	15-16 (20.3-21.7)
L, LL	7/16-14	1.25	27-29 (36.6-39.3)	19-21 (25.8-28.5)	15-16 (20.3-21.7)
LS	1/2-13	1.25	40-43 (54.2-58.3)	30-32 (40.7-43.4)	22-24 (29.8-32.5)
Q, QS	5/8-11	1.25	80-85 (108.5-115.2)	60-65 (84.1-81.3)	44-49 (59.7-66.4)

FIGURE 20

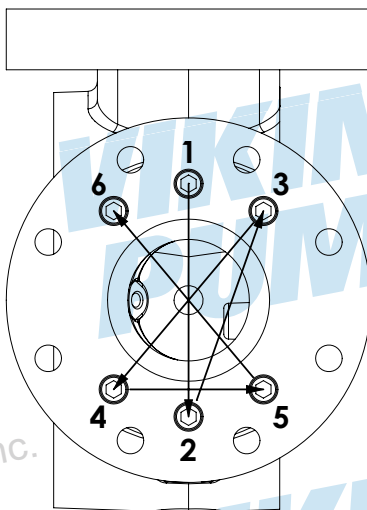
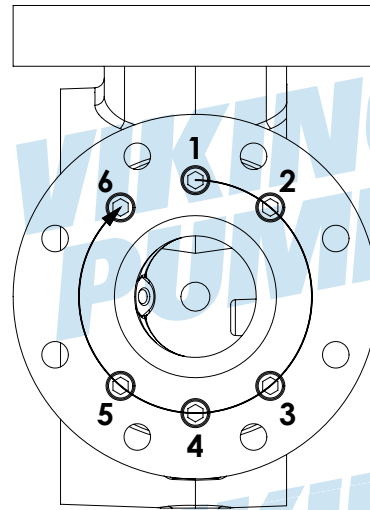

FIGURE 21



## ⚠ DANGER !

Before opening any Viking pump liquid chamber (pumping chamber, reservoir, relief valve adjusting cap fitting, etc.) be sure:

1. That any pressure in the chamber has been completely vented through the suction or discharge lines, or other appropriate openings or connections.
2. That the driving means (motor, turbine, engine, etc.) has been "locked out" or made non-operational, so that it cannot be started while work is being done on pump.
3. That you know what liquid the pump has been handling and the precautions necessary to safely handle the liquid. Obtain a material safety data sheet (MSDS) for the liquid to be sure these precautions are understood.

Failure to follow above listed precautionary measures may result in serious injury or death.

## THRUST BEARING ADJUSTMENT

1. Loosen the two set screws in the outer face of the bearing housing and rotate the bearing housing in a clockwise direction until it cannot be turned any more. This ensures the rotor is all the way forward and is touching the head. It will not be possible to turn the rotor by hand in this location.
2. Make a mark on the outside diameter of the bearing housing and a corresponding mark on the bearing bracket.
3. Rotate the bearing housing in a counter clockwise direction until the mark on the outside diameter of the bearing housing is past the mark on the bearing bracket per "Table 5" on page 15. This will provide the standard end clearance for the pump. If possible, check end clearance with feeler gauge between idler and rotor faces. Operating the pump at higher temperatures or viscosities may require additional end clearance. Contact your Viking Pump® representative for those clearances. "Table 5" on page 15 shows the additional bearing housing adjustment required for ".001" increase in end clearance.
4. Tighten setscrews in the outer face of the bearing housing.
5. Rotate the rotor shaft by hand to make sure it turns freely.

TABLE 5: END CLEARANCE CHART

Size	Series	Standard End Clearance (Inches)	Turn Bearing Housing CCW Length on OD (Inches)	Additional Length on OD Bearing Housing for .001" End Clearance (Inches)
H, HL	127C Series™ 1127C Series™ 4127C Series™	0.005	1.13	.22
	227C Series™ 1227C Series™ 4227C Series™	0.013	2.88	.22
	127C Series™ 1127C Series™ 4127C Series™	0.008	2.00	.25
K, KK	227C Series™ 1227C Series™ 4227C Series™	0.018	4.50	.25
	127C Series™ 1127C Series™ 4127C Series™	0.008	2.13	.265
L, LL	227C Series™ 1227C Series™ 4227C Series™	0.018	4.75	.265
	127C Series™ 1127C Series™ 4127C Series™	0.010	2.63	.26
LS	227C Series™ 1227C Series™ 4227C Series™	0.020	5.25	.265
	127C Series™ 1127C Series™ 4127C Series™	0.010	3.10	.31
Q, QS	227C Series™ 1227C Series™ 4227C Series™	0.020	6.20	.31

### INSTALLATION: CARBON GRAPHITE BUSHINGS

When installing carbon graphite bushings, extreme care must be taken to prevent breaking. Carbon graphite is a brittle material and easily cracked. If cracked, the bushing will quickly disintegrate. Using a lubricant and adding a chamfer on the bushing and the mating part will help in installation. The additional precautions listed below must be followed for proper installation.

1. A press must be used for installation.
2. Be certain bushing is started straight.
3. Do not stop pressing operation until bushing is in proper position. Starting and stopping will result in a cracked bushing.
4. Check bushing for cracks after installation.

### BRACKET BUSHING INSTALLATION: STUFFING BOX SEALS

1. Before installing bracket bushing, ensure the pump bore is clean and free of debris. Extra care must be taken when installing carbon graphite bushings See "**Installation: Carbon Graphite Bushings**" on page 15.
2. Bushing should be pressed into bore from casing side. Notched bushings are installed with notches facing bearing housing side of pump with the notches located at the 3 o'clock and 9 o'clock positions. If the bushing has a lubrication groove this should be located at the 12 o'clock position in the bracket.
3. The bushing should be pressed until face is flush with the face of the casing. The bushing can be pressed up to 0.005" past flush.
4. Inspect the bushing for damage after completing the pressing operation.

### BRACKET BUSHING INSTALLATION: BEHIND THE ROTOR SEAL

1. Before installing bracket bushing, ensure the pump bore is clean and free of debris. Extra care must be taken when installing carbon graphite bushings See "**Installation: Carbon Graphite Bushings**" on page 15.
2. Bushing should be pressed into bore from casing side. Notched bushings should always be installed with notches facing casing side with the notches located at the 3 o'clock and 9 o'clock positions. If the bushing has a lubrication groove this should be located at the 12 O'clock position in the bracket.
3. The bushing should be pressed to the appropriate depth "A" as outlined in "**Figure 22**" on page 15.

FIGURE 22

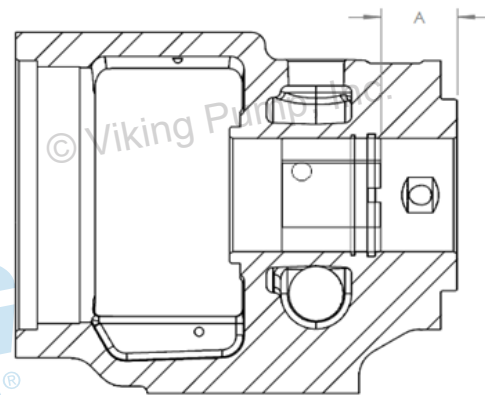

Pump Size	Installation Depth "A" (inches)
H-HL	1.39-1.40
K-KK	1.31-1.32
L-LS	1.53-1.54
Q-QS	1.77-1.78

4. The bushing should be inspected for damage after the pressing operating.

# PRESSURE RELIEF VALVE INSTRUCTIONS

FIGURE 23: RELIEF VALVE - ALL SIZES

NOTE: Image is representative only.

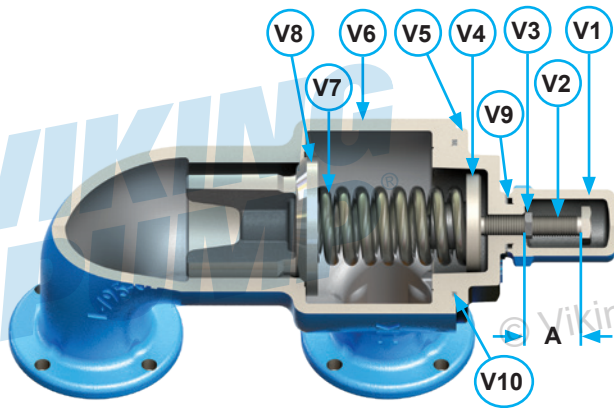

Valve - List Of Parts

V1.	Valve Cap	V6.	Valve Body
V2.	Adjusting Screw	V7.	Valve Spring(s)
V3.	Lock Nut	V8.	Poppet
V4.	Spring Guide	V9.	Cap Gasket
V5.	Bonnet	V10.	Bonnet Gasket*

\* K, KK, L, LL, LS, Q, QS sizes only

## DANGER !

Before opening any Viking pump liquid chamber (pumping chamber, reservoir, relief valve adjusting cap fitting, etc.) be sure:

1. That any pressure in the chamber has been completely vented through the suction or discharge lines, or other appropriate openings or connections.
2. That the driving means (motor, turbine, engine, etc.) has been "locked out" or made non-operational, so that it cannot be started while work is being done on pump.
3. That you know what liquid the pump has been handling and the precautions necessary to safely handle the liquid. Obtain a material safety data sheet (MSDS) for the liquid to be sure these precautions are understood.

Failure to follow above listed precautionary measures may result in serious injury or death.

## DISASSEMBLY

Mark valve and head before disassembly to ensure proper reassembly.

1. Remove valve cap.
2. Measure and record length of extension of adjusting screw. Refer to "A" on "Figure 23" on page 16.
3. Loosen locknut and back out adjusting screw until spring pressure is released.
4. Remove bonnet, spring guide, spring and poppet from valve body. Clean and inspect all parts for wear or damage and replace if necessary.

## ASSEMBLY

Reverse procedures outlined under Disassembly. If valve is removed for repairs be sure to replace in same position. Relief valve adjusting screw cap must always point towards suction side of pump. If pump rotation is reversed, remove relief valve and turn end for end.

## PRESSURE ADJUSTMENT

If a new spring is installed or if pressure setting of pressure relief valve is to be changed from that which the factory has set, the following instructions must be carefully followed.

1. Carefully remove valve cap which covers adjusting screw. Loosen locknut which locks adjusting screw so pressure setting will not change during operation of pump.
2. Install a pressure gauge in discharge line for actual adjusting operation.
3. Turn adjusting screw CW (in) to increase pressure and CCW (out) to decrease pressure. For guidance dimensions, contact your Viking Pump® representative for Engineering Standard ES-37.
4. Close the discharge line at a point beyond the pressure gauge. Limit the amount of time the pump is being operated at this condition. The temperature inside the pump will rise rapidly. Gauge will show maximum pressure that valve will allow while pump is in operation.
5. Once pressure is set, tighten locknut and replace cap gasket and valve cap.

## IMPORTANT ORDERING INFORMATION

In ordering parts for pressure relief valve, always give model number and serial number of pump as it appears on nameplate and name of part wanted. When ordering springs, be sure to give pressure setting desired.



## APPENDIX (FORMERLY TSM 000)

**NOTE:** This Appendix section is for reference only. Not all pump construction features apply to pumps within this Technical Service Manual.

### GENERAL INSTALLATION NOTES

Before installation is started, a few items of a general nature should be considered.

- 1. Location** - always locate the pump as close as possible to the supply of liquid to be pumped. Locate it below the liquid supply if at all practical. Viking pumps are self priming but the better the suction conditions the better the performance.
- 2. Accessibility** - the pump should be located where it is accessible for inspection, maintenance, and repair. For large pumps, allow room to remove the rotor and shaft without removing the pump from the base.
- 3. Port Arrangement** - since the pumps have different port arrangements depending on the model, port location should be checked before starting the installation. The ports may be upright, opposite or at right angles to each other, see **Figure A1**. The right angle ports are normally right-hand, see **Figure A2**; some models are available with left-hand arrangements; still other models are available with the right angle ports located in any one of eight positions including right-hand and left-hand.
- 4. Suction/Discharge** - shaft rotation will determine which port is suction and which is discharge. A look at **Figure A3** will show how rotation determines which port is which. As the pumping elements (gears) come out of mesh, point "A" on **Figure A3**, liquid is drawn into the suction port. Then at point "B" the gears come into mesh, and the liquid is forced out the discharge port. Reversing the rotation reverses the flow through the pump. When determining shaft rotation, always look from the shaft end of the pump. Unless otherwise specified, rotation is assumed to be clockwise (CW), which makes the suction port on the right side of the pump. The idler pin, which is offset in the pump head, should be properly positioned toward and an equal distance between the port connections. See **Figure A3** for correct idler pin location in relation to pump ports.

**FIGURE A1**

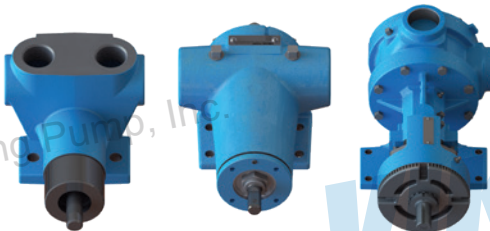

**FIGURE A2**



**FIGURE A3**

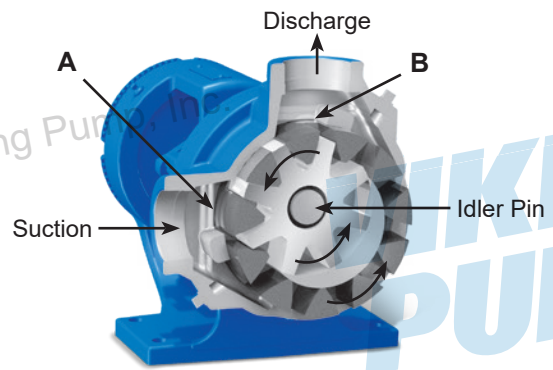

**FIGURE A4: CUTAWAY OF VIKING INTERNAL PRESSURE RELIEF VALVE**

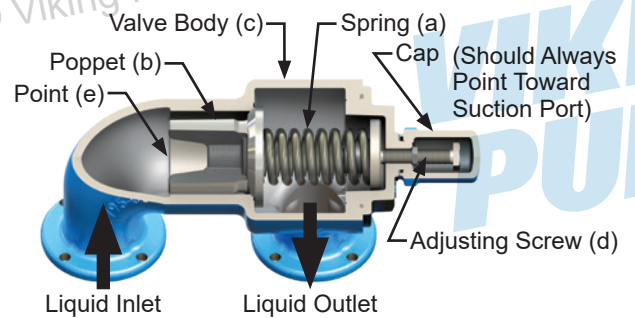

**FIGURE A5-A: INTERNAL PRESSURE RELIEF VALVE**

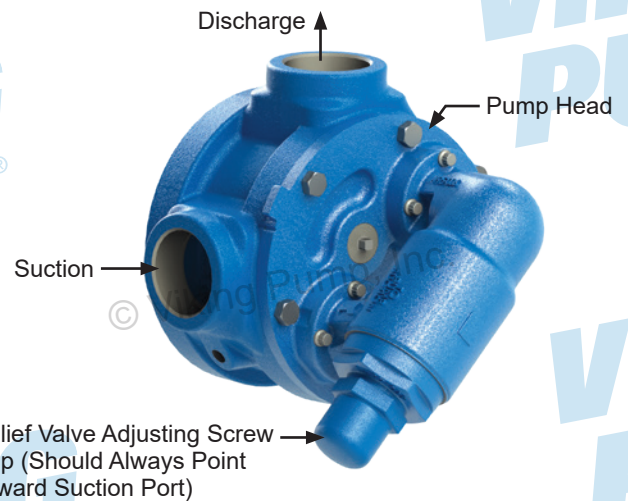

**FIGURE A5-B:  
RETURN-TO-TANK PRESSURE RELIEF VALVE**

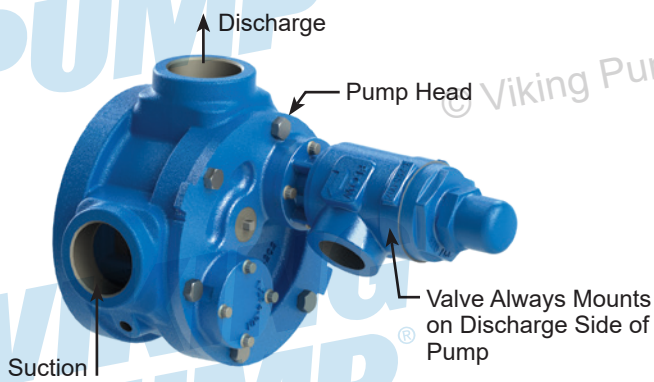

**CAUTION !**

Internal type relief valves mounted on Viking pumps should always have the cap or bonnet pointed toward the suction side of the pump. Return-to-tank type relief valves should always be mounted on the discharge side of the pump. If pump rotation is reversed, change the relief valve. Turn the internal type end for end; move the return-to-tank type to the other port. If on a particular installation rotation is reversed, e.g., using one pump to fill a tank, and then by use of a reversing switch or other means of changing the rotation to permit the same pump to circulate the liquid through a heater or to load out, then pressure protection must be provided on both sides of the pump for both rotations. This may be a combination of relief valves, torque limiting devices or rupture disks.

**CAUTION !**

Pumps or systems without relief valves should have some form of pressure protection, e.g. torque limiting devices or rupture disks.

**5. Pressure Protection** - Viking pumps are positive displacement pumps. This means that when the pump is rotated, liquid will be delivered to the discharge side of the pump. If there is no place for this liquid to go, i.e. the discharge line is blocked or closed, pressure can build up until the motor stalls, the drive equipment fails, a pump part breaks or ruptures, or the piping bursts. Because of this, some form of pressure protection must be used with a positive displacement pump. This may be a relief valve mounted directly on the pump, an inline relief valve, a torque limiting device or a rupture disk.

The pressure relief valve mounted on most Viking pumps and most in-line valves are of the spring-loaded poppet design. See **Figure A4**. The spring (a) holds poppet (b) against the seat in the valve body (c) with a given force determined by the spring size and by how tightly it is compressed by the adjusting screw (d). The pump discharge pressure pushes against the underside of the poppet at point (e). When the force exerted by the liquid under the poppet exceeds that exerted by the spring, the poppet lifts and liquid starts to flow through the valve.

As the discharge pressure builds up, more and more of the liquid flows through until a pressure is reached at which all of the liquid being pumped is going through the valve. This pressure is the relief valve setting.

Viking pumps can be furnished with either an internal pressure relief valve - one which directs the flow from the valve back to the suction side of the pump - or a return-to-tank valve - which directs the flow through piping back to the supply tank. See **Figure A5-A** and **Figure A5-B**. An inline relief valve mounted in the discharge piping also directs the flow back to the supply tank. This type of valve should be mounted close to the pump so that the pressure drop through the piping between the pump and the valve is at a minimum. Be sure there are no shutoff valves between the pump and relief valve. Piping from a return-to-tank or an in-line valve to the supply tank should also be as short and as large as possible.

**NOTE:** On some models, the relief valve is mounted on the pump casing instead of the pump head.

The spring-loaded poppet-type valve is strictly a differential valve, sensing only those pressures on each side of the poppet. It should not be used as a pressure or flow control device. It is intended strictly as a relief valve.

The pressure at which either the return-to-tank or internal relief valve bypasses can be changed by turning the adjusting screw. Do not back the adjusting screw all the way out. Stop when spring tension is off the screw (the screw starts to turn easily). For details on maintenance of the relief valve, refer to the Technical Service Manual covering your model series.

**6. Motor** - follow local electrical codes when hooking up motors.

**FOUNDATION**

Every pump should have a solid foundation. It may be any structure sufficiently strong to hold the pump rigid and to absorb any strain or shock that may be encountered.

A certified print of the pumping unit should be used in preparing the foundation. If a separate foundation is provided, make it at least four inches wider and longer than the base of the unit.

When the unit is placed on the foundation, it should be leveled and checked for position against the piping layout and then fastened down.

**COMPONENT & UNIT LIFTING FEATURES**

Removable lifting features, such as threaded eye bolts and hoist rings, installed in components (pumps, reducers, motors, etc.) and baseplates should be left on the components. These features are used to safely lift and move the individual components. Following are general guidelines for lifting Viking Pump® units.

**FIGURE A6:  
EXAMPLE OF PROPER LIFTING METHOD**

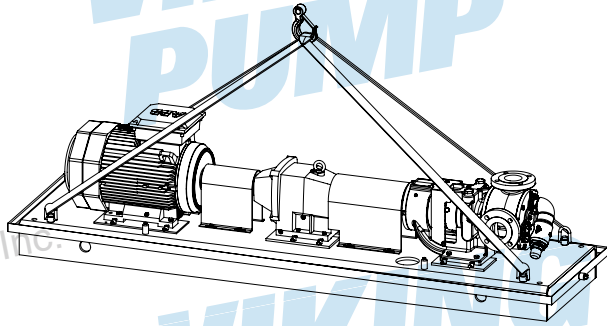

**NOTE:** Units should be lifted by the base lifting features using two or more lifting slings.

**FIGURE A7:  
EXAMPLES OF PROPER LIFTING METHOD**

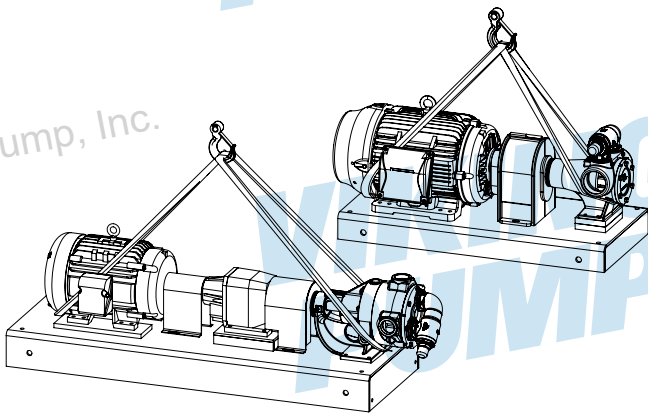

**NOTE:** Use two or more lifting slings around the pump and the motor when the base does not have lifting features. Make sure the slings are secure and the load is balanced before attempting to lift.

**FIGURE A8:  
EXAMPLE OF IMPROPER LIFTING METHOD**

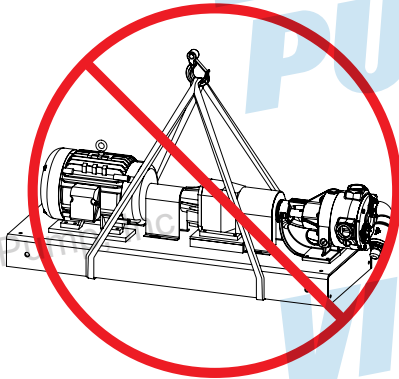

**NOTE: NEVER** lift the unit with slings unsecured under the base. The slings can slide, allowing the unit to tip and/or fall. Improper lifts can result in personal injury and/or damage to the unit.

**FIGURE A9  
EXAMPLE OF IMPROPER LIFTING METHOD**

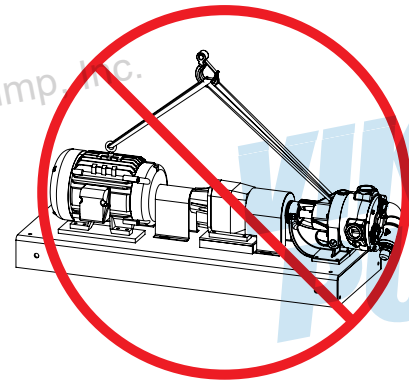

**NOTE: NEVER** lift the unit with slings connected to the component lifting features. The lifting features are designed for the individual component and are not rated to lift the entire unit. Improper lifts can result in personal injury and/or damage to the unit.

**FIGURE A10-A**

Use a straightedge. These surfaces must be parallel.

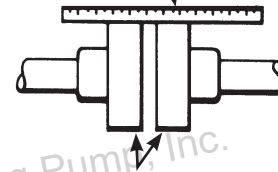

Check width between these surfaces with inside calipers to be certain the faces are equal distance apart and parallel.

**FIGURE A10-B**

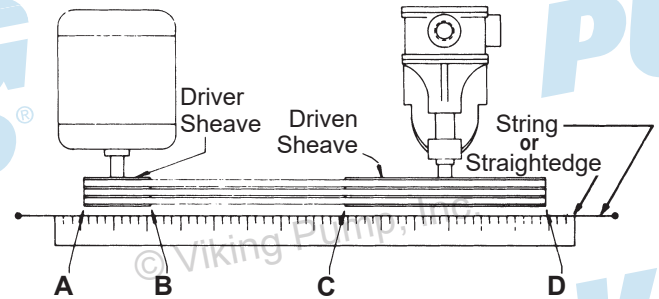

When sheaves are properly aligned, all points A, B, C, D will touch string or straightedge.

## ALIGNMENT

### CHECK ALIGNMENT AFTER MOUNTING

For detailed coupling alignment procedures see coupling manufacturers' recommendations.

The pump, drive, and motor were properly aligned at the time they were assembled. During shipping and mounting the alignment is often disturbed. **BE SURE TO RECHECK ALIGNMENT AFTER THE PUMP UNIT IS INSTALLED!**

1. Check pump ports to be sure they are square and in the proper position; shim or move the pump as required. Do not force piping to line up with the ports.
2. If the pump is driven by a flexible coupling(s) either directly connected to the motor or through a reducer, remove any coupling guards or covers and check alignment of the coupling halves. At a minimum, a straightedge (such as a piece of key stock) across the coupling must rest evenly on both rims at the top, bottom, and sides. See **Figure A10-A**.
3. If the pump is driven by V-belts, check the alignment by using a long straightedge or tightly drawn string across the face of the sheaves. See **Figure A10-B**.
4. Make a final check on alignment after piping is hooked up. Refer to item 13 in **Piping** section.

**Figure A11** and **Figure A12** show typical direct drive and gear reducer drive units.

5. For high temperature applications (those above 300°F) allow the pump to reach operating temperature, then recheck alignment.

**FIGURE A11: DIRECT DRIVE**

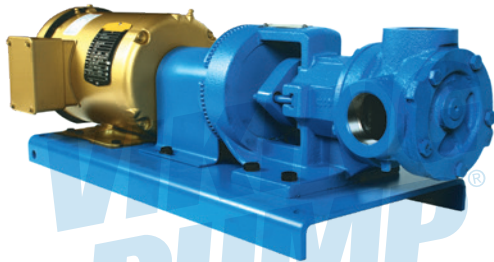

**FIGURE A12: REDUCER DRIVE**

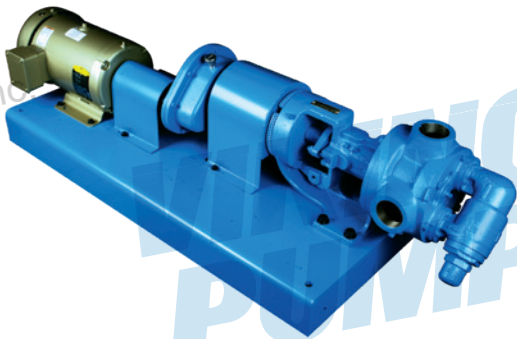

## PIPING

The cause of many pumping problems can be traced to suction piping. It should always be as large and short as practical. For help in selecting the proper size suction and discharge piping, refer to **Viking General Catalog Section 510**.

Before starting the layout and installation of your piping system, consider the following points:

1. Never use piping smaller than the pump port connections.
2. Be sure the inside of the pipe is clean before hooking it to the pump.
3. **FOOT VALVE** - When pumping a light liquid with a suction lift, a foot valve at the end of the suction piping or a check valve in the first horizontal run will hold the liquid in the line and make it easier for the pump to prime. Be sure the foot or check valve is big enough so that it doesn't cause excessive line loss.
4. When approaching an obstacle in the suction or discharge line, go around the obstacle instead of over it. Going over it creates an air pocket. See **Figure A13**.
5. Where practical, slope the piping so no air or liquid pockets will be formed. Air pockets in the suction line make it hard for the pump to prime.
6. For a suction line with a long horizontal run, keep the horizontal portion below the liquid level if possible. This keeps the pipe full of liquid and reduces the amount of air the pump must evacuate at startup. This is most helpful when there is no foot valve. See **Figure A14**.
7. When piping a hot or cold system (liquid being handled is at a temperature different from the air surrounding the pump), be sure allowance is made for expansion and contraction of the piping. Loops, expansion joints, or unsecured (this does not mean unsupported) runs should be used so the pump casing is not distorted.
8. **STRAINER** - It is always good practice to consider a strainer on the suction side of a positive displacement pump. The strainer will keep foreign objects from going into the pump. Without a strainer objects can lock the pump, and damage the internals and drive. The strainer basket mesh or perforation size should be big enough so that it does not cause excessive pressure drop, but it should be fine enough to protect the pump. When in doubt as to the proper size, check with the manufacturer, giving pipe size, flow rate, and viscosity involved. Provision should be made for cleaning the strainer. If the pump operates continuously, a bypass should be built around the strainer, or two strainers should be put in parallel with proper valving so they can be isolated for cleaning. Use of a strainer is particularly important at start up to help clean the system of weld beads, pipe scale, and other foreign objects. For additional information, refer to **TSM 640**.
9. If the pump is not equipped with a relief valve, consideration should be given to mounting one in the discharge line. Refer to discussion on pressure protection under item 5 in **General Installation Notes** section.
10. The pump should not be used to support the piping. The weight of the piping should be carried by hangers, supports, stands, etc.
11. When fastening the piping to the pump it should not be necessary to impose any strain on the pump casing. "Springing" or "drawing" the piping up to the pump will

cause distortion, possible misalignment, and probable rapid wear of the pump. Do not use the pump to correct errors in piping layout or assembly.

12. All joints of the piping system should be tight; pipe sealer will help assure leak-free threaded joints. Leaks in the suction line permitting air to be drawn in may cause a noisy pump or a reduction in capacity. It is not recommended to use PTFE tape on NPT ports as a pipe sealer. This action can result in cracks in the pump.
13. **ALIGNMENT** - Check the alignment of the drive after the piping is hooked up. As a final check on pump alignment, remove the head of the pump and with a feeler gauge determine if there is clearance all the way around between the rotor and casing. Because of manufacturing tolerances, bushing clearances, etc., the rotor may not be centered in the casing, but it should not drag; dragging would indicate unit misalignment or casing distortion from piping strain. Making this check is most desirable on installations involving Q, M and N size general purpose pumps.
14. The auxiliary piping hooked to jackets, glands, etc. for heating, cooling, quenching, or for other purposes should receive the same attention as the piping handling the pumped liquid.
15. Provide a pressure relief device in any part of a pump and piping system that can be valved off and, thus, completely isolated. This is particularly important:
  - a. When handling a cold liquid such as refrigeration ammonia that can warm up to ambient temperatures when the pump is shut off.
  - b. When handling a liquid such as asphalt or molasses that has to be heated before it can be pumped.

The rise in temperature causes the liquid to expand; if there is no provision for pressure relief in the closed off section, there is a chance that the pump or piping will rupture.

**FIGURE A13**

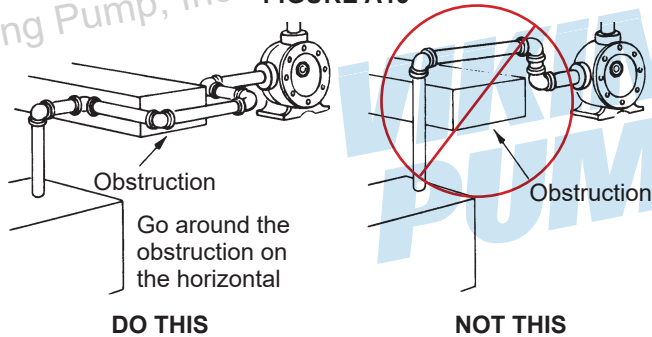

**FIGURE A14**

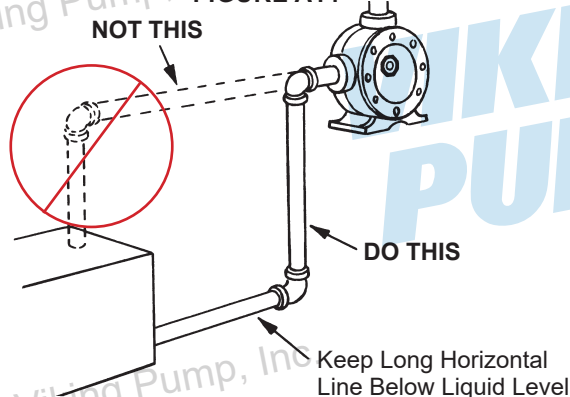

## START UP

Before starting the pump, check the following:

1. Are there vacuum and pressure gauges on or near the pump? These gauges are the quickest and most accurate way of finding out what is happening in the pump.
2. Check alignment - See suggestions in the Alignment section of this manual.
3. Check piping to be sure there is no strain on the pump casing.
4. Rotate the pump shaft by hand to be sure it turns freely. **MAKE SURE THE PUMP DRIVER IS LOCKED OUT OR CANNOT BE ENERGIZED BEFORE DOING THIS.**
5. Jog motor to be sure it is turning in the right direction; refer to discussion on pump rotation under item 4 in **General Installation Notes** section.
6. Check any relief valves to be sure they are installed correctly. Refer to discussion on relief valves in **General Installation Notes** section.
7. Check suction piping to be sure:
  - a. It is all connected and tight
  - b. Valves are open
  - c. End of pipe is below liquid level
8. Check discharge piping to be sure:
  - a. It is all connected and tight
  - b. Valves are open
  - c. There is a place for the liquid to go
9. Lubricate any grease fitting on the pump using a #2 NLGI grease. Check any gear reducer, motor, coupling, etc. for instructions and lubricate as recommended by the manufacturer. See **Engineering Service Bulletin ESB-515** at the end of the **Appendix** for Viking standard grease types to check compatibility.
10. For packed pumps, loosen packing gland nuts so gland can be moved slightly by hand. Adjust gland to reduce leakage only after pump has run long enough to reach constant temperature. Packing should weep a little to keep it cool and lubricated.
11. Do not use the Viking pump to flush, pressure test or prove the system with water. Either remove the pump or run piping around it while flushing or testing. Pumping water, dirty or otherwise, can do more damage in a few minutes than months of normal service.
12. Check to be sure all guards are in place.
13. Check the pump to be sure it is heated to operating temperature (if jacketed or heat traced).

If the pump begins to deliver liquid within 60 seconds, it can continue to be operated. If liquid is not leaving the discharge port, stop the pump. Running the pump longer than one minute without liquid inside it can damage the pump. Review the steps just outlined, consider what the suction and discharge gauges indicate, and see **Troubleshooting** section. If everything appears to be in order, put some liquid in the pump. This will help it prime.

The pump can be restarted. If nothing is flowing within two minutes, stop the pump. The pump is not a compressor; it will not build up much air pressure. It may be necessary to vent the discharge line until liquid begins to flow.

If the pump still does not deliver flow, the cause may be one or more of the following:

1. Suction line air leaks. Vacuum gauge reading should help determine if this is the problem.
2. End of suction pipe not submerged deep enough in liquid.
3. Suction lift is too great or the suction piping is too small.
4. Liquid is vaporizing in the suction line before it gets to the pump.

If after consideration of these points it still does not pump, review again all points under **START UP**. Read through **Troubleshooting** in this manual and try again. If it still does not pump, contact your Viking Pump® representative.

## TROUBLESHOOTING

A Viking pump that is properly installed and maintained will give long and satisfactory performance.

**NOTE:** Before making any pump adjustment or opening the pump liquid chamber in any manner, make sure that:

1. Any pressure in the pumping chamber has been vented through the suction or discharge lines or other openings provided for this purpose.
2. The driver has been “locked out” so that it cannot inadvertently be started while work is being done on the pump.
3. The pump has been allowed to cool down to the point where there is no chance of anyone being burned.

If trouble does develop, one of the first steps toward finding the difficulty is to *install a vacuum gauge in the suction port and a pressure gauge in the discharge port*. Readings on these gauges often will give a clue as to where to start looking for the trouble.

### VACUUM GAUGE - SUCTION PORT

#### 1. High reading would indicate:

- a. Suction line is blocked by a stuck foot valve, stuck gate valve, or plugged strainer.
- b. Liquid is too viscous to flow through the piping.
- c. Lift is too high.
- d. Line is too small.

#### 2. Low reading would indicate:

- a. Air leak in suction line.
- b. End of pipe is not in liquid.
- c. Pump is worn.
- d. Pump is dry - should be primed.

#### 3. Fluttering, jumping, or erratic reading:

- a. Liquid is vaporizing.
- b. Liquid is coming to pump in slugs, possibly an air leak, insufficient liquid above the end of the suction pipe.
- c. Vibrating from cavitation, misalignment, or damaged parts.

### PRESSURE GAUGE - DISCHARGE PORT

#### 1. High reading would indicate:

- a. High viscosity, small diameter discharge line or long discharge line.
- b. Gate valve is partially closed.
- c. Filter is plugged.
- d. Vertical head did not consider a high specific gravity liquid.
- e. Line is partially plugged from build up on inside of pipe.
- f. Liquid in the pipe is not up to temperature.
- g. Liquid in the pipe has undergone a chemical reaction and has solidified.
- h. Relief valve is set too high.

#### 2. Low reading would indicate:

- a. Relief valve is set too low.
- b. Relief valve poppet is not seating properly.
- c. Bypass around the pump is partially open.
- d. Too much extra clearance.
- e. Pump is worn.

#### 3. Fluttering, jumping, or erratic reading:

- a. Cavitation.
- b. Liquid is coming to the pump in slugs.
- c. Air leak is in the suction line.
- d. Vibrating from misalignment or mechanical problems.

**Some of the following may also help pinpoint the problem:**

#### A. Pump does not pump.

1. Pump has lost its prime due to air leak, low level in tank, foot valve stuck.
2. Suction lift is too high.
3. Rotating in wrong direction.
4. Motor does not come up to speed.
5. Suction and discharge valves not open.
6. Strainer is clogged.
7. Bypass valve open, relief valve set too low, relief valve poppet stuck open.
8. Pump is worn out.
9. Any changes in the liquid system or operation that would help explain the trouble, e.g. new source of supply, added more lines, inexperienced operators, etc.
10. Too much end clearance.
11. Head position is incorrect. See **Figure A3**.
12. Temperature changes either in the liquid or environment.
13. **Mag Drive pumps ONLY:** The magnetic coupling is decoupling. Changes in application (temperature, pressure, viscosity, etc.) may require torque beyond coupling capabilities.

#### B. Pump starts, then loses its prime.

1. Supply tank is empty.
2. Liquid is vaporizing in the suction line.
3. Air leaks or air pockets in the suction line; leaking air through packing or mechanical seal.
4. Pump is worn out.

**C. Pump is noisy.**

1. Pump is being starved (heavy liquid cannot get to pump fast enough). Increase suction pipe size or reduce length.
2. Pump is cavitating (liquid vaporizing in the suction line). Increase suction pipe size or reduce length. If pump is above the liquid, raise the liquid level closer to the pump. If the liquid is above the pump, increase the head of liquid.
3. Check alignment.
4. May have a bent shaft or rotor tooth. Straighten or replace.
5. Relief valve chatter. Increase pressure setting.
6. May have to anchor base or piping to eliminate or reduce vibration.
7. May be a foreign object trying to get into the pump through the suction port.
8. **Mag Drive pumps ONLY:** The magnetic coupling has decoupled. Shut off and let cool, then restart.

**D. Pump not up to capacity.**

1. Starving or cavitating. Increase suction pipe size or reduce length.
2. Strainer partially clogged.
3. Air leak in suction piping or along pump shaft.
4. Running too slowly. Check the motor is running at the correct speed and that it is wired correctly.
5. Bypass line around pump partially open.
6. Relief valve set too low or stuck open.
7. Pump is worn out.
8. Too much end clearance.
9. Head position incorrect. See **Figure A3**.
10. **ProPort™ casing ONLY:** Ensure that internal circulation plugs were installed correctly for application conditions.

**E. Pump takes too much power.**

1. Running too fast. Verify the motor speed, reducer ratio, sheave size, and other drive components are correct for the application?
2. The liquid is too viscous for the size of the unit. Heat the liquid to reduce viscosity, increase the pipe size, slow down the pump, or use a larger motor.
3. Discharge pressure higher than calculated. Verify with a pressure gauge. Increase size or reduce length of pipe, reduce speed (capacity), or get bigger motor.
4. Packing gland drawn down too tight.
5. Pump misaligned.
6. Extra clearance on pumping elements may not be sufficient for operating conditions. Check parts for evidence of drag or contact in pump and increase clearance where necessary.
7. System pressure relief valve is set too high.
8. Bushings have locked to shaft or pin, or the liquid has set up in the pump.

**F. Rapid Wear.**

On most applications the pump will operate for many months or years before it gradually loses its ability to deliver capacity or pressure. Examination of such a pump would show a smooth wear pattern on all parts. Rapid wear, occurring in a few minutes, hours or days, shows up as heavy grooving, galling, twisting, breaking or similar severe signs of trouble. See **Rapid Wear Table**.

**RAPID WEAR**

**RAPID WEAR TABLE**

CAUSE	EVIDENCE	POSSIBLE SOLUTION
1 ABRASIVES	Gouges or marks made by large, hard particles; a rapid wearing away of bushings from very small abrasives; or anything in between.	Flush the system with the pump removed. Install strainer in suction line. Most abrasive objects and particulate is removed after a few cycles (or days) of flushing.
2 CORROSION	Rust, pitting or metal appears to be "eaten" away.	Check the Viking General Catalog Liquid List for materials of construction recommendation. Consider whether all of the materials used in pump construction were attacked; consider other materials used in the system to determine how they resisted the liquid. Check to see whether or not the liquid has been contaminated to make it more corrosive than anticipated.
3 EXCEEDING OPERATING LIMITS	Noisy operation, broken bushings, twisted shaft, parts show evidence of high heat (discoloration).	Review General Catalog for operating limits on particular model involved.
4 INSUFFICIENT EXTRA CLEARANCE	Pump may stall. Evidence of heavy contact between end of rotor teeth and head or other parts.	Increase end clearance and/or contact your Viking Pump® representative with details of the application, so that information regarding proper extra clearance may be provided.
5 LACK OF LUBRICATION	Noisy bearings, localized heating at bearings or lip seal, smoke, rapid bushing wear.	Be sure all grease fittings are greased before starting, and instructions for lubrication of drive equipment are followed; consider use of auxiliary lubricating equipment.
6 MISALIGNMENT	Wear on only one part of a surface, e.g., one side of the casing, one side of the packing gland, only a portion of the face of the head.	Double check alignment of drive equipment and piping. Check the alignment under conditions as close to operating conditions as possible.
7 RUN DRY	Pump stalls because parts have uneven expansion caused by frictional heat; galling between surfaces having relative motion; seal seats and idler pins changing color because of high heat.	Be sure there is liquid in the system at the time of start up. Provide some kind of automatic alarm or shut-off if supply tank runs dry.

## PREVENTATIVE MAINTENANCE

Performing a few preventative maintenance procedures will extend the life of your pump and reduce the overall cost of ownership.

**A. Lubrication** - Grease all grease fittings after every 500 hours of operation. If service is severe, grease more often. Do it gently with a hand gun until the grease exiting the lip seal or relief plug is similar in consistency and color to the new grease.

Use a NLGI #2 grease for normal applications. See

**ESB-515** at the end of the **Appendix** for Viking standard grease types to check compatibility. For hot or cold applications, use appropriate grease.

O-Pro® seals should also be greased every 500 hours of operation with a lubricating fluid compatible with the process fluid.

**B. Packing Adjustment** - Occasional packing adjustment may be required to keep leakage to a slight weep. If impossible to reduce leakage by gentle tightening, replace packing or use different type. *Refer to Technical Service Manual on particular model series for details on repacking.*

**C. End Clearance Adjustment** - After long service, the running clearance between the end of the rotor teeth and the head may have increased through wear. This wear may cause a loss of capacity or pressure. Resetting end clearance will normally improve pump performance. *Refer to TSM on particular model series for procedure on adjusting end clearance for pump involved.*

**D. Examine Internal Parts** - Periodically remove the head, examine idler and bushing and head and pin for wear. Replacing a relatively inexpensive idler bushing and idler pin after only moderate wear will eliminate the need to replace more expensive parts at a later date. *Refer to TSM on particular model series for procedure in removing head of the pump.* Be sure idler does not slide off the idler pin as the head is removed. If it does slide off the idler can cause personal injury or damage the part.

**E. Cleaning the Pump** - A clean pump is easier to inspect, lubricate, adjust, and runs cooler.

**F. Storage** - If pump is to be stored or not used for six months or more, pump must be drained, and a light coat of non-detergent SAE 30 weight oil must be applied to all internal pump parts. Lubricate fittings and apply grease to pump shaft extension. Viking suggests rotating pump shaft by hand one complete revolution every 30 days to circulate the oil. Retighten all gasketed joints before using the pump.

## DO'S & DON'TS

Do's and Don'ts for installation, operation, and maintenance of Viking pumps to assure safe, long, trouble-free operation.

### INSTALLATION

1. **DO** install pump as close to supply tank as possible.
2. **DO** leave working space around the pumping unit.
3. **DO** use large, short, and straight suction piping.
4. **DO** install a strainer in the suction line.
5. **DO** double check alignment after the unit is mounted and piping is hooked up.
6. **DO** provide a pressure relief valve for the discharge side of the pump.
7. **DO** cut out the center of gaskets used as port covers on flanged port pumps.
8. **DO** record pump model number and serial number and file for future reference.

### OPERATION

1. **DON'T** run pump at speeds faster than shown in the catalog for your model.
2. **DON'T** require pump to develop pressures higher than those shown in the catalog for your model.
3. **DON'T** operate pumps at temperatures above or below limits shown in the catalog for your pump.
4. **DON'T** operate pumps without all guards being in place.
5. **DON'T** operate pump without a relief valve on the pump or in the discharge piping. Be sure valve is mounted and set correctly.
6. **DON'T** exceed catalog limits for temperature and pressures of fluids in jacketed areas of pump.
7. **DON'T** use the pump in a system which includes a steam, air, or vapor blow or purge **without** provision for over-speed shutdown, in case the pump starts to act as a turbine and over-speeds the drive.
8. **DON'T** operate the pump with all of the liquid bypassing through a pump mounted internal type relief valve, or without any flow of liquid going through the pump for more than a couple of minutes. Operation under either of these conditions may result in a heat build-up in the pump, which could cause hazardous conditions or happenings.



## MAINTENANCE

1. **DO** make sure any pump that has residual system pressure in it, or that has handled high vapor pressure liquids, such as LP-gas, ammonia, Freons, etc., has been vented through the suction or discharge lines or other openings provided for this purpose.
2. **DO** make sure that if the pump is still hooked to the driver while maintenance is being performed that the driver has been "locked out", so that it cannot be inadvertently started while work is being done on the pump.
3. **DO** make sure any pump that has handled a corrosive, flammable, hot, or toxic liquid has been drained, flushed, vented and/or cooled before it is disassembled.
4. **DO** remember that a few simple preventative maintenance procedures such as periodic lubrication, adjustment of end clearance, examination of internal parts, etc., will extend the service life of your pump.
5. **DO** obtain, read and keep maintenance instructions furnished with your pump.
6. **DO** have spare parts, pumps or standby units available, particularly if the pump is an essential part of a key operation or process.
7. **DON'T** drop parts during disassembly, e.g., idler can slip from the pin as the head is removed from the pump. It may cause personal injury or damage the part.
8. **DON'T** stick fingers in the ports of a pump. Serious injury may result.
9. **DON'T** spin the idler on the idler pin. Fingers may be jammed between teeth and crescent.

## ESB-515

Effective 25-July-19

### LUBRICATION OF VIKING PUMPS

Usage of Grease	General Description of Grease Used by Viking	Viking Recommended Supplier
Grease used for anti-friction bearings, sleeve bearings and lantern rings	Premium EP, Multi-purpose polyurea base grease	Any NLGI Grade 2 premium quality, multi-purpose, polyurea grease
Grease used for bracket bushing when seal is behind rotor	Petrolatum	Chevron Petrolatum Snow White
Grease used for O-Pro® Barrier Guard Seals	Edible Grease, aluminum complex	Chevron FM ALC EP 0, 1, 2
Grease used for O-Pro® Cartridge Seals	High Temperature Grease	Misty Ultra High Temp Superfilm G00735

Lubricate each grease fitting every 500 hours of operation or every six months, whichever occurs first. If service is severe, grease more often. Be sure the grease is compatible with the grease used by Viking. Grease used for the bracket bushing and O-Pro® Seal should be compatible with the liquid being pumped.

**Reservoir on Ammonia Pumps:** The Series 4924A ammonia pumps are shipped without oil in the reservoir. Before start-up, fill the reservoir with one pint of Light Refrigeration Oil that is compatible with the Neoprene seal and with a maximum viscosity of 15,000 SSU at operating temperature. Drain and refill the reservoir after the first 200 hours of operation and every 1000 hours thereafter. Refer to Technical Service Manual TSM 1467.

**Pumping Chamber of Stainless Pumps:** All internal parts are coated with test fluid to avoid galling when the pump is first installed. Be sure the pump is kept full of liquid when in operation to prevent damage to the pump.

### LUBRICATION OF VIKING REDUCERS

Viking gear reducers, "A", "B", "C" sizes use SAE 30 oil above 32°F and SAE 10W oil below 32°F.

- A Size: 3/8 PT. (6 oz)
- B Size: 1/2 PT. (8 oz.)
- C Size: 2-1/4 PT. (36 oz.)

Viking gear reducers are shipped less oil. Before start-up, fill to proper level with quantity and type of oil shown in box at left. After first 100 hours of operation, drain and refill with new lubricant. Check lubricant level every 2000 hours or every six months. Once each year, drain and refill.

### LUBRICATION OF VIKING ASSOCIATIVE EQUIPMENT

Check any motor, coupling, gear reducer or other drive equipment for manufacturer's instructions and lubricate as recommended.

**TECHNICAL SERVICE MANUAL: INSTALLATION, OPERATION & MAINTENANCE**



UNIVERSAL PRODUCT LINE: **STAINLESS STEEL**

127C SERIES™, 1127C SERIES™, 4127C SERIES™,  
227C SERIES™, 1227C SERIES™, 4227C SERIES™

**SIZES: H, HL, K, KK, L, LL, LS, Q, QS**

<b>TSM</b>	<b>2700</b>
<b>Page</b>	<b>26 of 26</b>
<b>Issue</b>	<b>A</b>

**VIKING PUMP®**

**WARRANTY**

Viking pumps, strainers and reducers are warranted to be free of defects in material and workmanship under normal conditions of use and service. The warranty period varies by type of product. A Viking product that fails during its warranty period under normal conditions of use and service due to a defect in material or workmanship will be repaired or replaced by Viking. At Viking's sole option, Viking may refund (in cash or by credit) the purchase price paid to it for a Viking product (less a reasonable allowance for the period of use) in lieu of repair or replacement of such Viking product. Viking's warranty is subject to certain restrictions, limitations, exclusions and exceptions. A complete copy of Viking's warranty, including warranty periods and applicable restrictions, limitations, exclusions and exceptions, is posted on Viking's website ([www.vikingpump.com/warranty#information](http://www.vikingpump.com/warranty#information)). A complete copy of the warranty may also be obtained by contacting Viking through regular mail at Viking Pump, Inc., 406 State Street, Cedar Falls, Iowa 50613, USA.

THIS WARRANTY IS AND SHALL BE VIKING'S SOLE AND EXCLUSIVE WARRANTY AND IS IN LIEU OF ALL OTHER WARRANTIES, EXPRESS OR IMPLIED, INCLUDING, BUT NOT LIMITED TO, ALL WARRANTIES OF MERCHANTABILITY, FITNESS FOR A PARTICULAR PURPOSE AND NON-INFRINGEMENT, ALL OF WHICH OTHER WARRANTIES ARE EXPRESSLY EXCLUDED.

THE RIGHTS AND REMEDIES UNDER THIS WARRANTY ARE AND SHALL BE THE SOLE AND EXCLUSIVE RIGHTS AND REMEDIES AGAINST VIKING. EXCEPT FOR THE SPECIFIC LIABILITIES AND OBLIGATIONS PROVIDED UNDER THIS WARRANTY, VIKING SHALL HAVE NO LIABILITY OR OBLIGATION WITH RESPECT TO ANY PRODUCT CLAIMED TO BE DEFECTIVE IN ANY MANNER.

UNDER NO CIRCUMSTANCES SHALL VIKING BE LIABLE UNDER THIS WARRANTY OR OTHERWISE FOR SPECIAL, INCIDENTAL, INDIRECT, CONSEQUENTIAL OR PUNITIVE DAMAGES OF ANY KIND, INCLUDING, BUT NOT LIMITED TO, LOST OR UNREALIZED SALES, REVENUES, PROFITS, INCOME, COST SAVINGS OR BUSINESS, LOST OR UNREALIZED CONTRACTS, LOSS OF GOODWILL, DAMAGE TO REPUTATION, LOSS OF PROPERTY, LOSS OF INFORMATION OR DATA, LOSS OF PRODUCTION, DOWNTIME, OR INCREASED COSTS, IN CONNECTION WITH ANY PRODUCT, EVEN IF VIKING HAS BEEN ADVISED OR PLACED ON NOTICE OF THE POSSIBILITY OF SUCH DAMAGES AND NOTWITHSTANDING THE FAILURE OF ANY ESSENTIAL PURPOSE OF ANY PRODUCT.