

SPOONDRAIN

OPEN CHANNEL DRAINAGE



SpoonDrain - channelling innovation

The **SpoonDrain Open Channel Drainage System** brings smart design and fast installation together to give the ultimate open-channel drainage solution. SpoonDrain is constructed using **FRC**Pipes' unique high strength, light weight fibre-reinforced concrete composite which enables the product to be quickly and efficiently installed.

SpoonDrain is the product of choice for contractors seeking a different approach to open channel drainage systems.

Fast. Smart. Proven. Strong.

SPOONDRAIN

Open Channel Drainage

Suited to a range of projects, the **SpoonDrain** Open Channel Drainage system is constructed using high performance fibre-reinforced concrete pipe.

Using **SpoonDrain** as permanent formwork allows quick construction with minimal hand finishing of placed concrete. Available in sizes from 225mm up to 750mm, there is a size to suit any application.

SpoonDrain is not only versatile, it is proven and can be used for many applications including:

- Back of barrier drainage for retaining walls
- Drainage along the bottom of cuttings and retaining walls
- Channel drains alongside hardstand areas (grated covers can be used if required)
- Forming an open drain into concrete slabs.

Concrete Plinth Installation

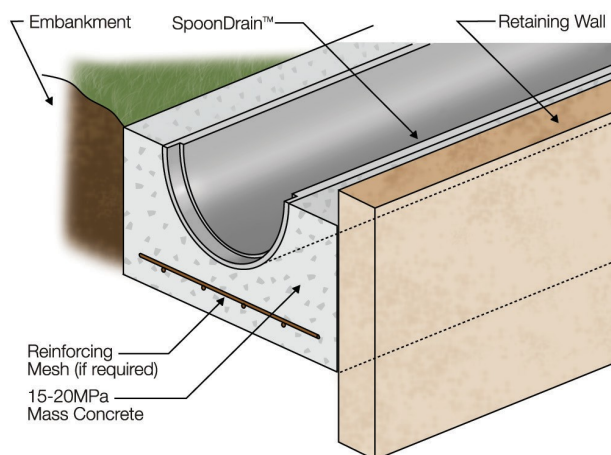
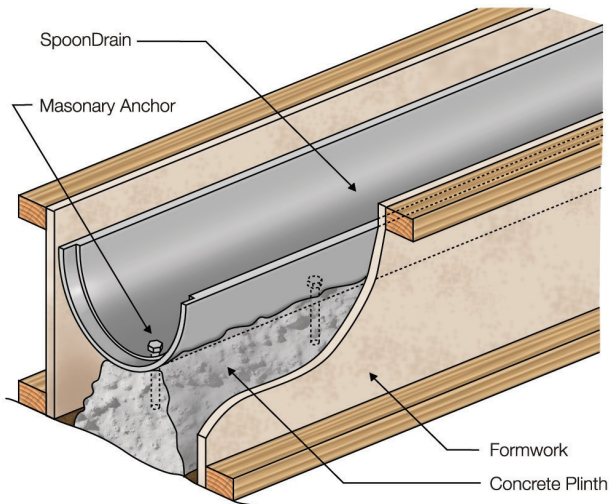

Timber Hanger Installation

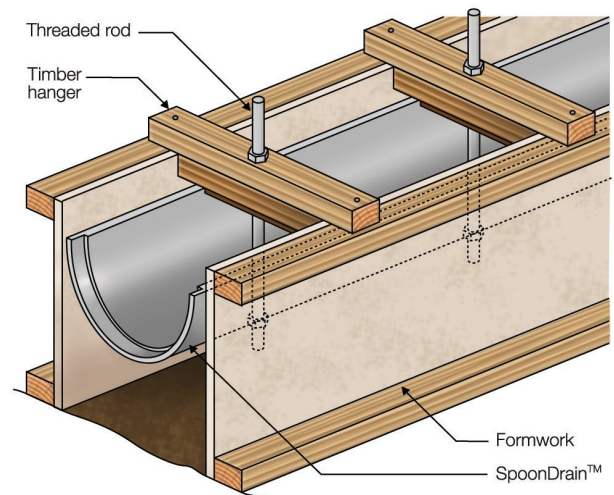

Sizes (mm)	Product Code	Approx. Mass (kg)
225	403128	49
300	403144	70
375	403165	98
450	402436	137
525	402368	172
600	402400	222
675	404759	292
750	403890	314