

FRC PIPE FITTINGS

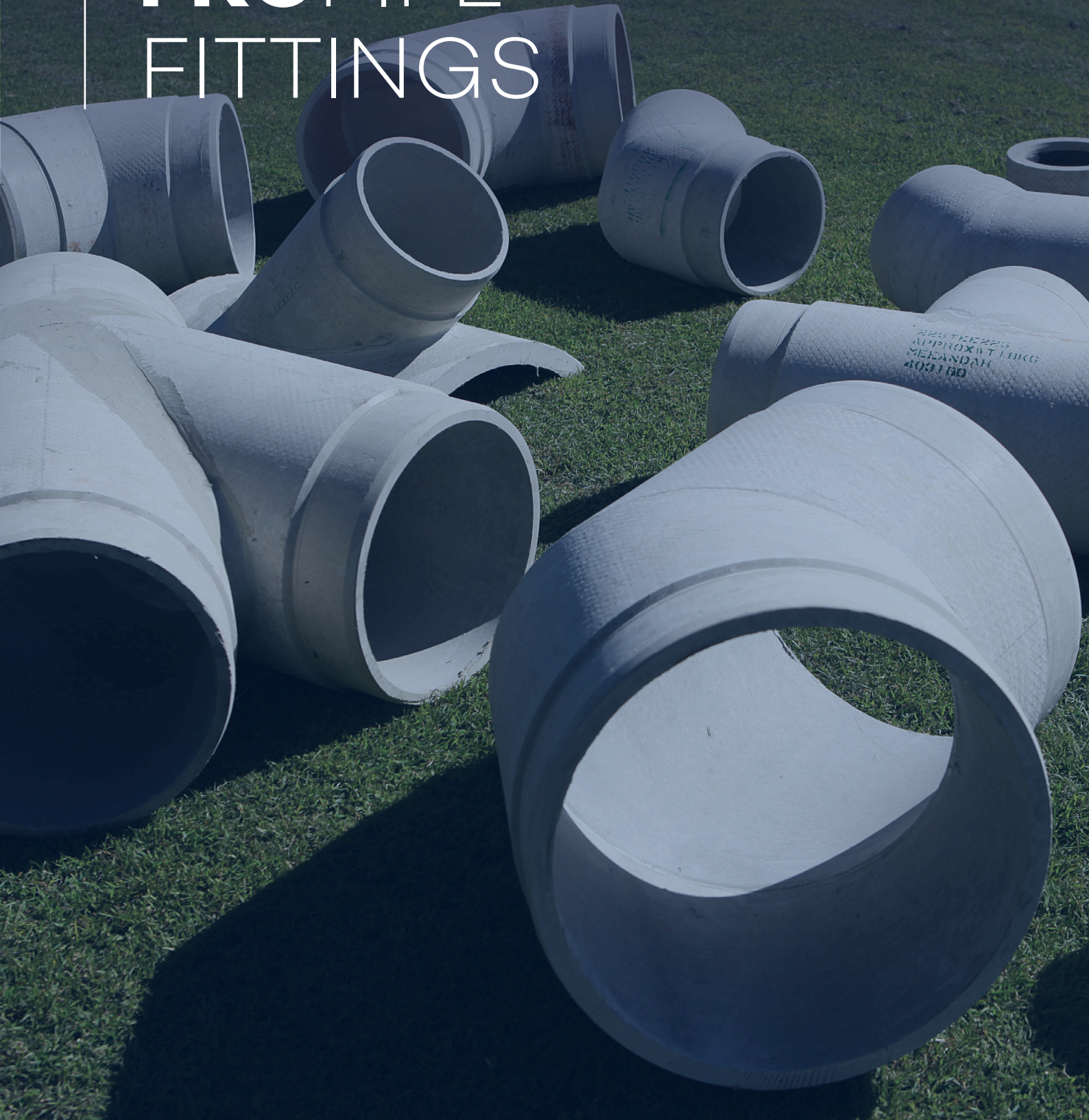

FRCPIPE FITTINGS

Overview

Description

RCPA manufactures an extensive range of fittings which are intended to provide maximum flexibility in the design and installation of stormwater drainage systems.

Application

As an integral part of the FRCPipe stormwater drainage system, FRCPipe fittings allow design flexibility and quick installation without sacrificing strength or durability.

Features

FRCPipe fittings allow a pipeline to:

- Change direction
- Join multiple lines
- Introduce branch lines
- Connect to other pipes with or without turnings.

This flexibility of use allows for considerable time savings during design and installation.

Cost of construction is also minimised, as the need for pits can be reduced or eliminated.

Bends, junctions and saddles are available in Class 2, while SuperTite to Unturned Adaptors and Unturned Couplings are available in both Class Two and Four.

Fittings can also be manufactured to meet individual project needs, including those in large sizes (ie: 525mm to 750mm).

Note:

Contact RCPA on 1800 88 7272 for delivery timeframes and terms and conditions.



Unturned to Unturned Couplings

Pipe Diam. (mm)	Product Code	Class	Dimensions (mm)		Approx. Mass (kg)
			O.D	L	
225	401686	2	345	310	10
225	403013	4	345	310	14
300	401695	2	431	310	18
300	403014	4	431	310	19
375	401704	2	520	310	19
375	401902	3	520	310	20
375	402741	4	520	310	25
450	401779	2	618	310	26
450	401903	3	618	310	28
450	403629	4	618	310	34
525	403000	2	718	310	26
525	403010	3	718	310	36
525	403011	4	718	310	46
600	403001	2	802	310	35
600	401780	3	819	310	59
600	413003	4	819	310	59
675	403002	2	837	310	45

Provides a transition from cut pipe to cut pipe.

Installation details are the same as SuperTite to Unturned Adaptor. Unturned couplings are also used near pit connections to provide flexible pit joints that can accommodate differential settlement.

Installation Details

1. Cut the end of the pipe square with a dustless or wet masonry saw
2. Fit an O-ring to the cut pipe and roll up and down the barrel of the pipe to take the twist out of the ring.
3. Position the ring as close as practical to the cut end of the pipe
4. Do not use lubricant as the O-ring must roll along the pipe and not slide
5. Position the adaptor squarely over the O-ring
6. Using a bar and block of timber push the adaptor squarely onto the pipe.

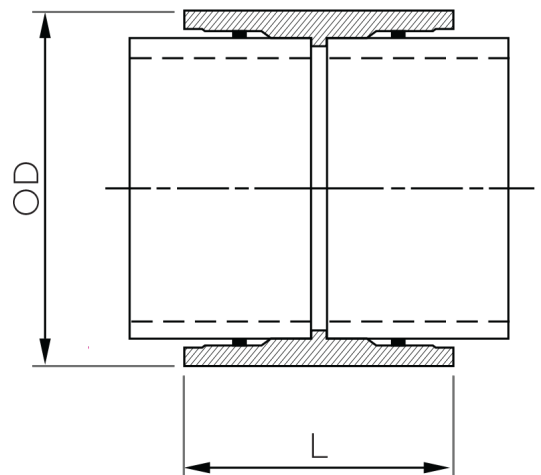

SuperTite Coupling

SuperTite Couplings are used as standard couplings for the SuperTite range of pipes and fittings. The SuperTite turning is a standard spigot on the pipe or fitting, with a SuperTite Coupling used with dual nitrile V-rings to provide a high integrity connection.

Pipe Diam. (mm)	Product Code	Dimensions (mm)		Approx. Mass (kg)
		O.D	L	
225	400866	345	160	5
300	400987	431	160	7
375	401129	520	180	12
450	401252	618	180	15
525	401370	718	180	18
600	401474	802	180	21
675	401568	837	180	26
750	401604	881	180	29

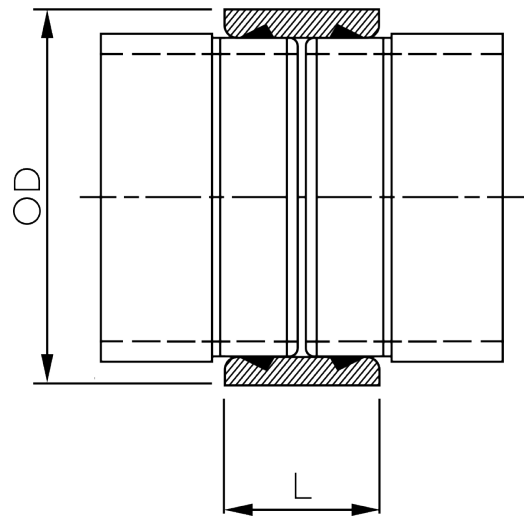

SuperTite to Unturned Adaptors

SuperTite to Unturned Adaptors are utilised when an installer needs to attach a fitting to a pipe that has been cut and no longer has the factory machined ends. Unturned Adaptors are used with both SuperTite and FRCPipe in underground applications.

SuperTite to Unturned Adaptors are not to be used in above ground suspended applications.

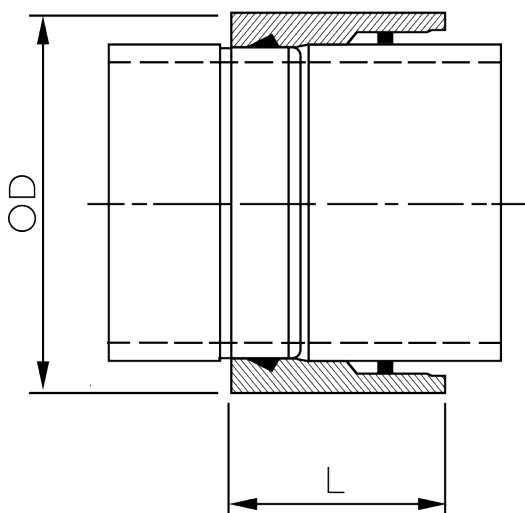

Pipe Diam. (mm)*	Product Code	Class	Dimensions (mm)		Approx. Mass (kg)
			O.D	L	
225	400850	2	345	230	10
225	400886	4	345	230	12
300	400972	2	431	230	14
300	400986	3	431	230	14
300	401014	4	431	230	16
375	401114	2	520	240	20
375	401128	3	520	240	20
375	401154	4	520	240	21
450	401239	2	618	240	26
450	401251	3	618	240	26
450	401272	4	618	240	30
525	401357	2	718	240	34
525	403015	3	718	240	31
525	401388	4	718	240	37
600	403030	2	802	240	41
600	401473	3	802	240	37
600	404091	4	802	240	43
675	403017	2	837	240	41
675	404227	3	871	240	45

SuperTite™ Reducer

Similar in design to the FRCPipe Reducer, the SuperTite Reducer allows change in diameter between SuperTite or PVC pipelines.

Reducer Size Pipe X Branch. (mm)	Product Code	Dimensions (mm)			
		Le	L1	L2	L3
225/150 PVC	400908	265	162	120	257
300/225	401085	350	252	120	336
300/225 PVC	401045	346	260	120	336
375/300	401203	431	340	120	415
450/375	401324	519	418	120	504
525/450	401434	603	507	120	584
600/525	401534	689	587	120	664

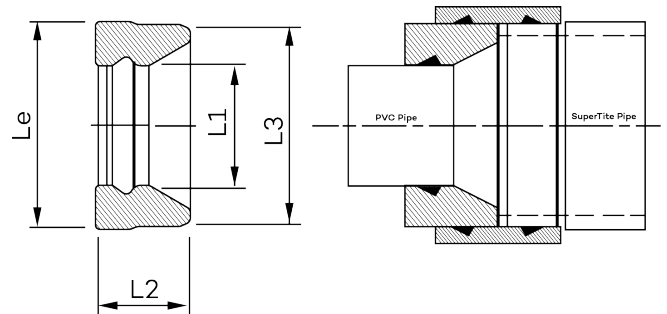

FRCPipe Reducer

FRCPipe reducers are an economical method of changing the pipe size in stormwater lines, often eliminating the need for a pit. To reduce more than one diameter size the installer must use multiple reducers; for example to reduce from a 375mm pipe to a 225mm pipe the installer will require a 375mm to 300mm reducer and a 300mm to 225mm reducer - these reducers will fit inside each other.

Installation Details

1. Fit the reducer into the socket end of the larger pipe using a bead of flexible construction adhesive
2. Fit the spigot end of the smaller diameter pipe with a rubber ring installed into the other end of the reducer

Pipe Diam. (mm)	Product Code	Dimensions (mm)			
		Le	L1	L2	L3
225/150 PVC	403121	235	163	70	228
300/225	403530	336	254	108	296
300/225 PVC	403122	305	252	70	298
375/300	403540	415	327	108	372
450/375	403541	495	407	108	452
525/450	403542	573	488	108	526
600/525	403543	653	567	108	602

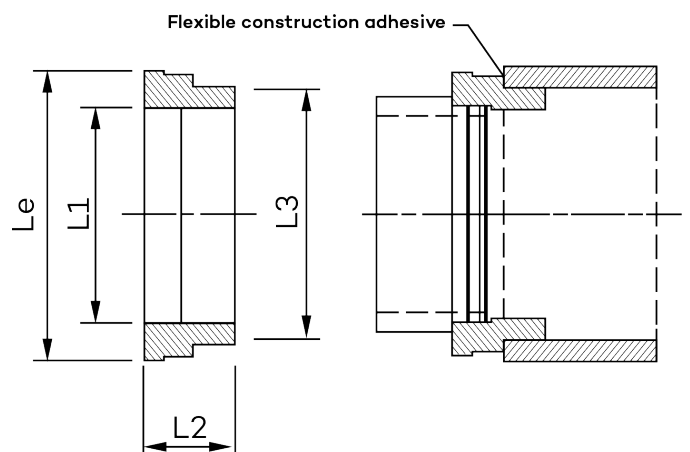

45° Bend

Allows the pipeline to change direction with FRCPipe or SuperTite pipe systems.

Pipe Diam. (mm)	Product Code	Dimensions (mm) L	Approx. Mass (kg)
225	400916	248	11
300	401053	248	14
375	401171	298	28
450**	401291	298	41
525**	401402	348	61
600**	401511	348	77
675**	404090	398	109
750**	401628	398	124

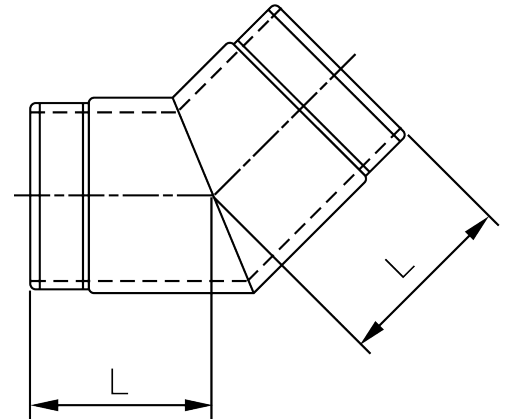

88° Bend

Pipe Diam. (mm)	Product Code	Dimensions (mm) L	Approx. Mass (kg)
225	400918	330	14
300	401055	395	24
375	401173	445	51
450**	401293	500	61
525**	401403	560	87
600**	401512	625	120
675**	404093	690	166
750**	401630	685	188

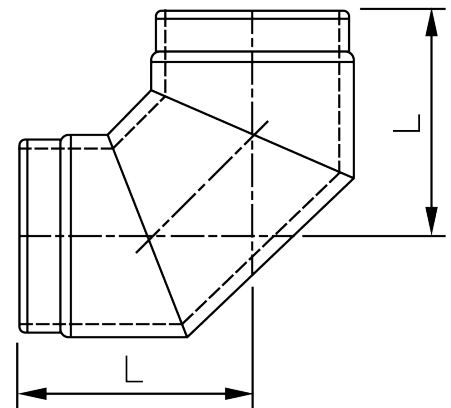

Equal Slope Junction

Pipe Diam. (mm)	Product Code	Le	Dimensions		Approx. Mass (kg)
			L1	L2	
225	400936	700	485	500	25
300	401076	900	625	585	41
375	401194	1000	715	685	67
450**	401315	1100	810	785	103
525**	401425	1300	950	885	147
600**	401525	1400	1045	1035	207

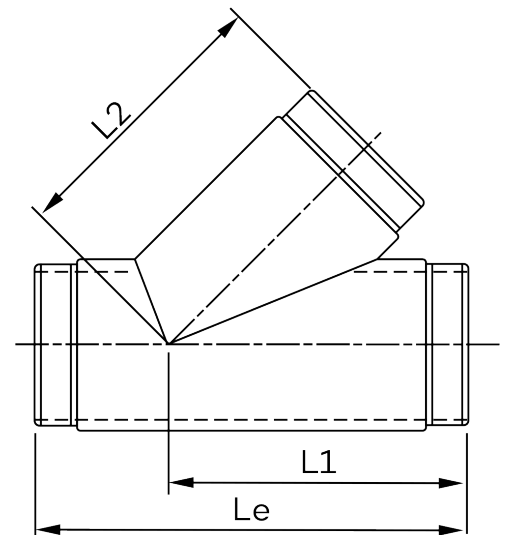

Note:

*Couplings required, ask RCPA on 1800 88 7272 for requirements.

**Non-stock items, ask RCPA on 1800 88 7272 for availability.

Other angles can be manufactured on request.

Saddle Slope

Branch lines can be cut into the main line at any point using the saddle slope. Attached with epoxy adhesive, the saddle slope has a SuperTite turning.

Saddle Slope Pipe/Branch*	Product Code	Dimensions			Approx. Mass (kg)
		Le	L1	L2	
300/225	401094	600	490	585	23
375/225	401213	600	530	640	18
375/300	401214	700	580	700	34
450/225	401335	600	575	695	21
450/300	401336	700	625	755	29

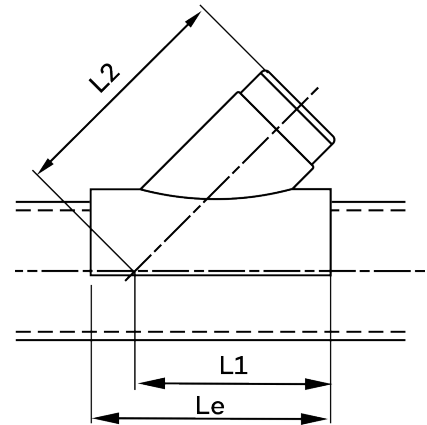

Saddle Tee Adaptor to PVC (150 DN)

150mm PVC lines can be cut into a FRCPipe line at any point using the saddle tee adaptor to PVC. Attached with epoxy adhesive, the tee adapter has a rubber v-ring included.

Saddle Slope Pipe/Branch*	Product Code	Dimensions			Approx. Mass (kg)
		Le	L1	L2	
225/150	400955	350	75	225	6
300/150	401098	350	75	280	8
375/150	401218	350	75	320	9

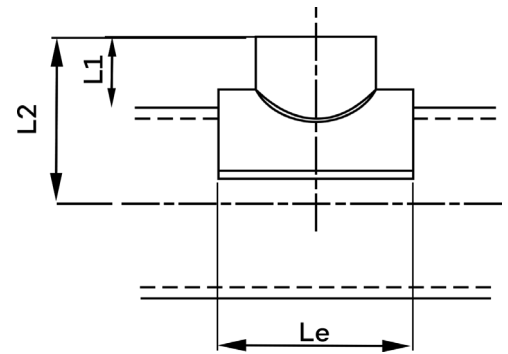

*Other sizes are available upon request, please ask RCPA on 1800 88 7272 for details.

PVC Saddle Slope Adaptor to PVC

Description	Product Code	Nominal Branch Size DN (mm)
225/300 PVC Slope Saddle	303734	100
375/450 PVC Slope Saddle	303735	100
525/600 PVC Slope Saddle	303736	100
675/750 PVC Slope Saddle	303737	100
225/300 PVC Slope Saddle	303738	150
375/450 PVC Slope Saddle	303739	150
525/600 PVC Slope Saddle	303740	150
675/750 PVC Slope Saddle	303741	150
375/450 PVC Slope Saddle	304670	225
525/600 PVC Slope Saddle	304672	225
675/750 PVC Slope Saddle	304674	225

Each PVC saddle fits two FRCPipe diameters, eg: 225 and 300, or 525 and 600 etc.

All saddles have a PVC spigot end only. Each saddle is supplied with plastic straps and clips for installation. We supply and recommend Z Bond V-4 adhesive.

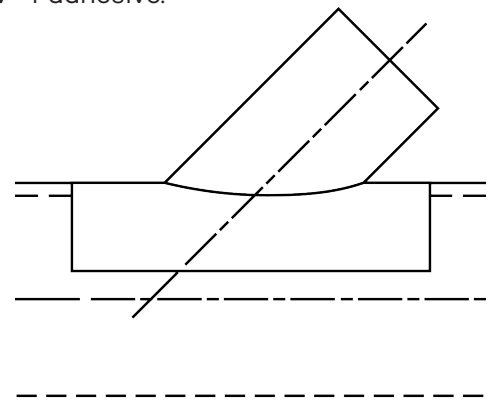



1800 88 7272

www.rcpa.com.au

Issue: November 2023