

# SafeGuard

## SuperSTAR<sup>®</sup>

Student Transportation Add-On Restraint

### Usage and Care Instructions



#### **SUPERSTAR**

- 26.5 – 90 lbs.  
(12 – 40.8 kg)
- 52 in. (132 cm) tall or less
- at least 1 year of age\*

\* See page 3 for details



\*966488\*

# Table Of Contents

---

Store this instruction manual under the SUPERSTAR removable seat pad.

	Page
General Information .....	1
Registration Information.....	1
General Warnings.....	2
Features .....	2
Weight & Height Limitations.....	3
Installation .....	3
Harness Buckle Positioning.....	5
Securing Child .....	6
Chest Strap Option.....	8
Emergency Evacuation.....	9
Care & Maintenance .....	9
Accessories/Replacement Parts .....	Back Cover

## General Information

---

The SafeGuard team truly cares about child passenger safety and is committed to providing innovative restraints that offer the utmost in safety and ease of use. While no restraint can prevent injury in every situation, proper installation and use of a restraint can substantially reduce a child's risk of serious injury or death.

It is critical to read and understand these instructions and the vehicle manufacturer's instruction BEFORE using this restraint. Failure to properly use this restraint may result in serious injury or death of the child being transported. If you have any questions after reviewing the instructions, please contact us at:

**SafeGuard Customer Service:** [www.safeguardseat.com](http://www.safeguardseat.com) (or) 1-877-447-2305.

**This restraint system conforms to all applicable Federal Motor Vehicle Safety Standards.**

## Registration Information

---

Please fill out the prepaid registration card attached to the restraint and mail it today or register online at the website listed below.

Restraints could be recalled for safety reasons. You must register this restraint to be reached in a recall. Send your name, address, the restraint's model number, manufacturing date and serial number to IMMI, 18881 IMMI Way, Westfield, IN 46074 or call 1-877-447-2305 or register online at [www.safeguardseat.com/clients/product-registration/](http://www.safeguardseat.com/clients/product-registration/).

For recall information, call the U.S. Government's Vehicle Safety Hotline at 1-888-327-4236 (TTY: 1-800-424-9153), or go to <http://www.NHTSA.gov>.

The restraint model number and manufacture date are located on a printed label sewn to the webbing above the seating platform.

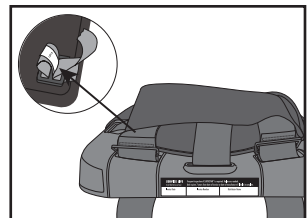

# General Warnings

## **⚠ WARNING**

This restraint must only be used on school bus seats. Entire seat directly behind must be unoccupied or have restrained occupants.

FAILURE TO FOLLOW THESE WARNINGS CAN RESULT IN SERIOUS INJURY OR DEATH. PLEASE READ AND FOLLOW ALL INSTRUCTIONS CAREFULLY.

- DO NOT USE THIS RESTRAINT UNTIL YOU READ AND UNDERSTAND THE INSTRUCTIONS IN THIS MANUAL.
- FOLLOW ALL INSTRUCTIONS ON THE RESTRAINT AND IN THIS MANUAL.
- DO NOT MODIFY THIS RESTRAINT OR USE ANY ACCESSORIES OR PARTS SUPPLIED BY OTHER MANUFACTURERS. USE ONLY SAFEGUARD REPLACEMENT PARTS.
- NEVER USE THE RESTRAINT SYSTEM IF IT IS DAMAGED OR MISSING PARTS. DO NOT USE A CUT, FRAYED OR DAMAGED HARNESS OR SEAT BELT.
- DO NOT USE BLEACH OR HARSH CLEANSERS ON SEATING CUSHIONS, WEBBING OR BUCKLES. NEVER LUBRICATE THE SEAT BELT BUCKLES.
- A CHILD RESTRAINT SHOULD BE PROPERLY SECURED EVEN WHEN UNOCCUPIED SINCE AN UNSECURED CHILD RESTRAINT MAY INJURE OTHER OCCUPANTS IN A CRASH.
- MULTIPLE SUPERSTAR UNITS MAY BE USED ON A SINGLE SEAT BUT THE COMBINED WEIGHT OF PASSENGERS SHOULD NEVER EXCEED 180 LBS.

# Features

## **SUPERSTAR**

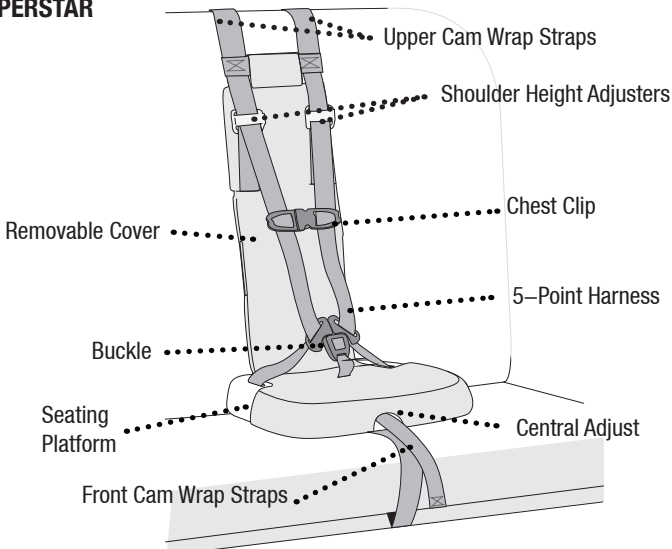

# Weight & Height Limitations

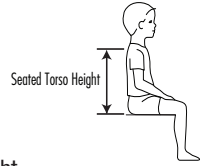

## SUPERSTAR

- 26.5 – 90 lbs. (12 – 40.8 kg)
- at least 1 year of age\*
- 52 in. (132 cm) tall or less
- 20 in. (50 cm) or less seated torso height

\* Caregivers should follow NHTSA best practice child car seat recommendation: Children under 1 should always ride in rear-facing car seats; and children 1 – 3 years of age (should) ride in rear-facing car seats as long as possible and until they reach the upper height or weight limit according to the manufacturers' instructions. **A child must be a minimum of 1 year of age and 26.5 lbs to use this restraint. Check your state codes.**

## Installation on the school bus seat

**Important Note:** SUPERSTAR may be secured to a standard 222 school bus seat unless your state code requires that the seat be FMVSS 210 reinforced. Check your state codes.

### **⚠ WARNING! DEATH or SERIOUS INJURY can occur:**

- Follow all instructions on the child restraint and in this manual. Failure to follow the manufacturer's warnings for proper use of this child restraint system can result in serious injury or death.

1. Position the SUPERSTAR restraint on the bus seat. Place the three upper cam wrap straps around the top of the school bus seat back. Insert the two lower cam wrap straps through the opening at the rear of the school bus seat cushion. **A**

Webbing should route in **FRONT** of the rear cross tube if possible (see inset).

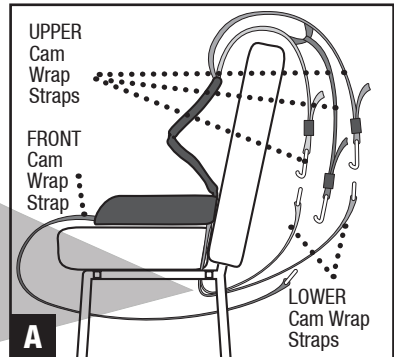
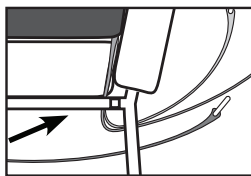

2. If the opening at the rear of the school bus seat cushion is blocked, lift the school bus seat cushion as shown in **B**. Thread the two lower cam wrap straps through the opening. Lower the seat cushion to its original position and lock into place. Be sure the lower cam wrap straps are not trapped within the seat cushion.

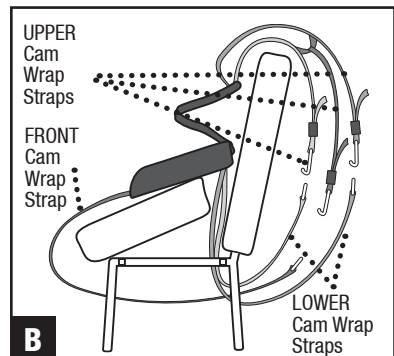

3. Connect the left upper cam wrap strap to the left lower cam wrap strap. Connect the right upper cam wrap strap to the right lower cam wrap strap. Pull adjuster straps to tighten both outside cam wrap straps. **C & D**

**Important:** Be sure to secure and tighten the two outer cam wrap straps before connecting the middle cam wrap strap. Proper tightening will compress the foam at the top of the school bus seat by approximately a half inch.

4. Connect the middle upper cam wrap strap to the front cam wrap strap. Pull adjuster strap to tighten. **E**

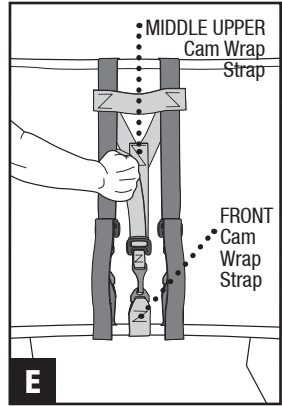
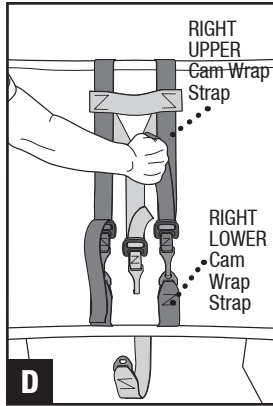
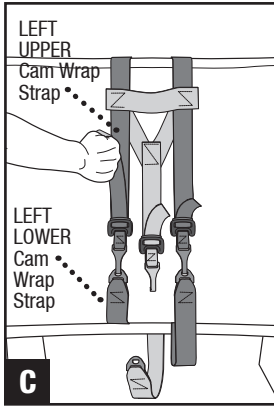

5. Verify the security of the restraint by moving the rear of the seating platform sideways. It should move less than one inch.

6. Once all straps are tight and secured, use the plastic keeper on each strap to secure the free ends of the three upper cam wrap straps. **F**

**Important:** Straps must appear as in **G** after installation is complete.

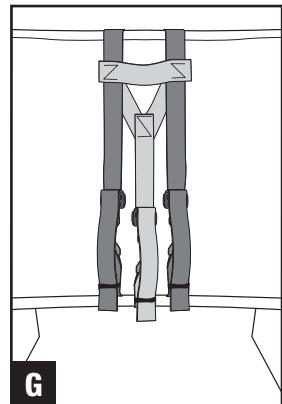
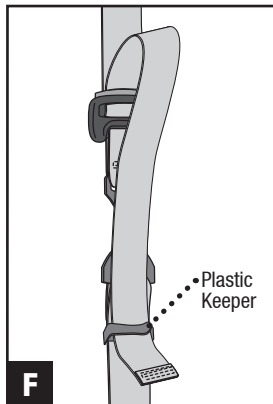

# Harness Buckle Positioning

## For SUPERSTAR

1. Use rear buckle slot for securing most children under 65 lbs. **A**

- Buckle strap should always be snug but comfortable for child. Too much slack may lead to improper securement of child.
- If child is over 65 lbs., choose the next slot.
- If the buckle position needs to be changed, follow steps 2 and 3.

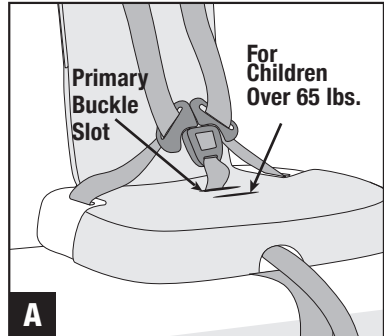

2. If SuperSTAR is already installed on bus seat:

- Unsnap grey (middle) cam strap on the back of the bus seat.
- Slightly loosen both black (outer) cam straps on the back of the bus seat.
- Lift front of seating platform towards the bus seat back to access bottom of restraint.

Adjust buckle to desired position: **B**

- With bottom of restraint facing up, move cover and webbing enough to access harness buckle bracket.
- Grasp buckle bracket and turn sideways to push through seat base.
- Re-install harness buckle bracket in desired position. **C**
- Pull up on harness buckle to ensure the harness buckle bracket is in place.

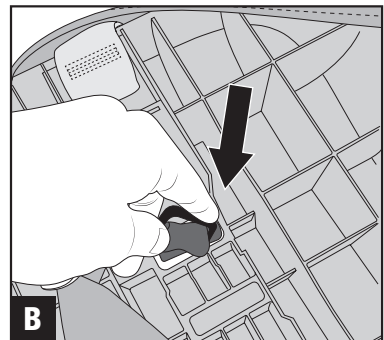

### NOTE:

Check that the release button on the buckle is facing AWAY from occupant.

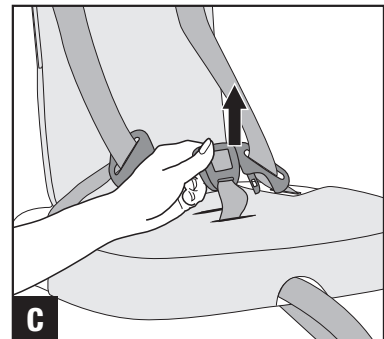

# Securing the Child

## **⚠ WARNING! DEATH or SERIOUS INJURY can occur:**

- Follow all instructions on the child restraint and in this manual. Failure to follow the manufacturer's warnings for proper use of this child restraint system can result in serious injury or death.
- Backpacks must be removed before using the SUPERSTAR restraint.
- Snugly adjust the belts provided with this restraint around the occupant.

### 1. Prepare harness:

- Loosen harness: Lift central adjust lock tab and pull down on left and right shoulder strap for full slack in harness strap. **A**
- Open chest clip and unbuckle harness.
- Lay buckle flat, toward front of restraint.

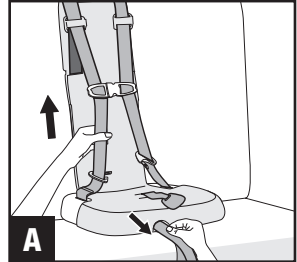

### 2. Place child in restraint: **B**

- Place child in restraint with child's back flat against the back of the restraint.
- Remove any twists from harness straps.
- Position harness shoulder straps over child's shoulders.

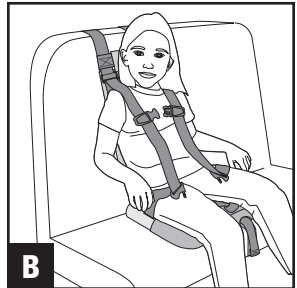

### 3. Buckle harness:

- Use buckle pull strap to pull buckle away from child.
- Make sure harness straps are not twisted.
- Insert buckle tongues into harness buckle. Listen for an audible click when each buckle tongue is fastened. **C**
- Check buckle connection is secure by pulling on shoulder straps.

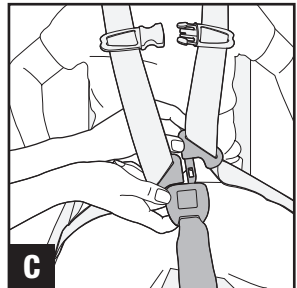

### 4. Tighten harness:

- Pull central adjust strap, located at the center front, until both harnesses are snug around the child. **D** Check to ensure all slack is pulled from lap—belts.
- A snug strap should not allow any slack. It lies in a relatively straight line without sagging. It does not press on the child's flesh or push the child's body into an unnatural position.
- Be sure the harness is snug and tight on both the thighs and chest before each use.

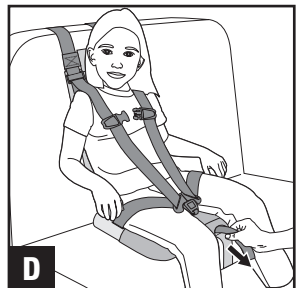

**5. Fasten harness chest clip: E**

- Fasten chest clip by pushing both sides together.
- Position chest clip at middle of child's chest, at armpit level.

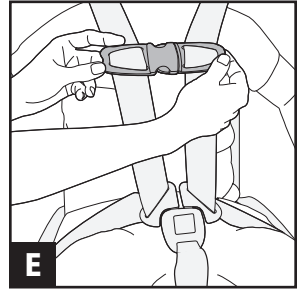

**6. Adjust harness height:**

- Position each yellow shoulder height adjuster at or just above child's shoulder. F

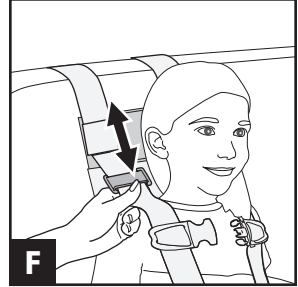

**To remove child from the child restraint:**

- Open chest clip by squeezing middle tabs and pulling apart. G
- Loosen harness: Pull shoulder straps forward from child while pulling up on the central adjust release tab located at the center front of the seating platform. H
- Use buckle pull strap to pull buckle away from child. Unbuckle harness buckle by pressing down on red release button. I
- Remove child.
- Rebuckle harness to prevent twisting of the straps.

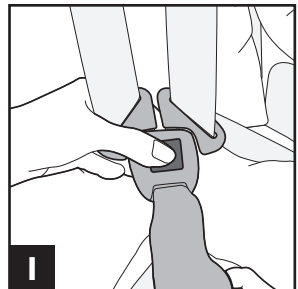
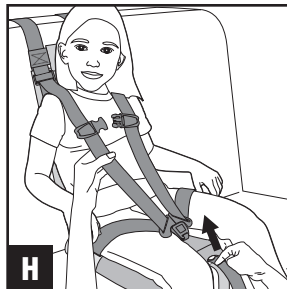
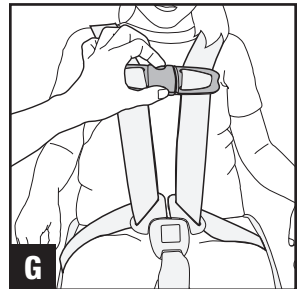



# Chest Strap option

For SUPERSTAR

## **⚠ WARNING! DEATH or SERIOUS INJURY can occur:**

- Orange chest strap is for positioning assistance only and is not a restraint device.
- Orange chest strap may not be substituted for shoulder straps or any other portion of SUPERSTAR restraint.
- Orange chest strap should be used only in addition to the full harness.
- Orange chest strap must be placed under the shoulder straps.

The SUPERSTAR chest strap is designed to provide positioning assistance for children with special needs.

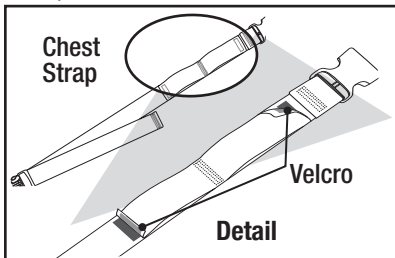

Chest Strap Option Installation:

1. Before the SUPERSTAR is installed onto the bus seat, slide the orange strap through the two loops on the back of the cover.
2. Secure each Velcro flap **OVER** the loops on the back cover. **A** You can then install the SUPERSTAR on the bus seat per instructions on pages 3 & 4.
3. Position the optional orange chest strap around the child's chest. Proper position of orange chest strap is at the middle of child's chest, at armpit level.
4. Fasten the orange chest strap buckle and adjust the strap snugly. A snug strap should not allow any slack. It lies in a relatively straight line without sagging. It does not press on the child's flesh or push the child's body into an unnatural position. **B**
5. Properly secure the child in the SUPERSTAR restraint system per instructions on pages 5 & 6. **C**

**Important: Orange chest strap must be placed under the shoulder straps.**

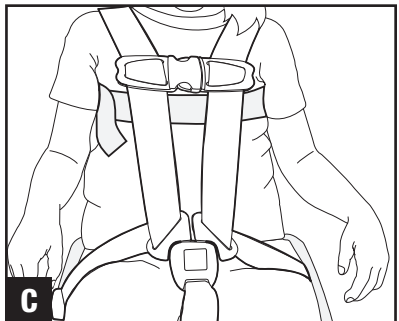
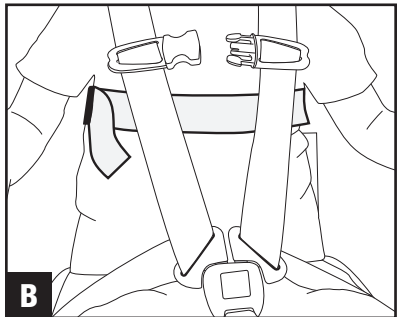
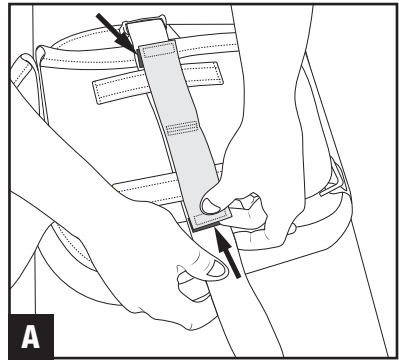

# Emergency Evacuation

## For SUPERSTAR

The SUPERSTAR restraint system is designed to remain operational after most crash situations. In the event of a crash or an event that necessitates an emergency evacuation, follow this procedure.

1. Open chest clip by squeezing middle tabs and pulling apart.
2. Unbuckle harness buckle by pressing down on red release button.
3. If not possible to perform Steps 1 and 2, use a belt cutter to cut shoulder webs below chest clip. **A** If optional orange chest strap is being used, cut chest strap on left side of child. **A**
4. Remove child.

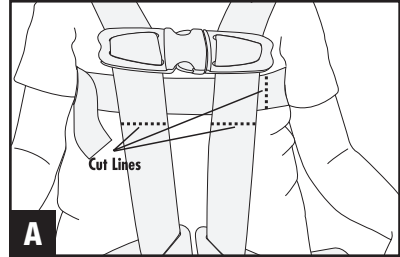

## Care and Maintenance

Only clean webbing and seating pad with a damp cloth using mild soap solution\* and lukewarm water. Before the surface dries, wipe with a clean, dry cloth to remove any residue. This procedure may be repeated to remove stubborn dirt or stains. DO NOT use any cleaning methods not listed above, as other methods may attack the vinyl and cause eventual degradation. AIR DRY only. DO NOT machine dry.

Buckle and buckle components: Wipe clean with a damp sponge, towel or cloth with lukewarm water only. Never use cleaning products on buckles or buckle components. These cleaning products can cause harm to the mechanisms.

Never use lubricating agents to clean because they will compromise the integrity the seat belt buckle

\* Approved mild soaps for solution with warm water are Ivory, Dreft, Woolite, and Dawn dishwashing soap.

*Note: Cleaning care and maintenance protocols are the responsibility of the owner. To maintain the integrity of the products, instructions must be followed. The owner assumes all responsibility for damages if he/she deviates from these cleaning instructions.*



**SCAN**  
for Detailed  
Cleaning  
Instructions

## SUPERSTAR Restraint Replacement

The SUPERSTAR restraint system is considered to have a finite life and must be frequently inspected and replaced as needed. The default service life of a SUPERSTAR restraint is 7 years from the date of manufacture. You may also use the date of invoice by following the directions below. Use of the SUPERSTAR must be discontinued seven years after the date of invoice or the date of manufacture if the invoice information label is not completed. The date of manufacture can be found between the webbing on the lower left back near the seat base. (Figure 1).

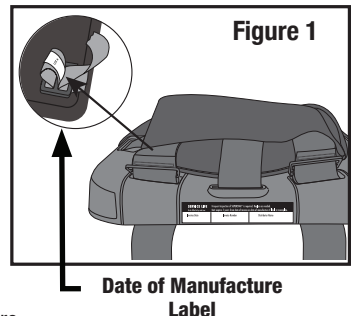

To activate the service life from date of invoice, locate the information label on the side of the SUPERSTAR base. You must enter Invoice Date, Invoice Number, and name of seller of your SUPERSTAR. All information must be entered for this to be valid. Remove the backing from the label clear cover and seal the label with the information you have entered (**Figure 2**).

The SUPERSTAR and its components must be inspected frequently (per instructions below). If you have any doubts about the condition or function of the restraint, REPLACE IT, even if it is less than 7 years from the date of service expiration.

If any component or part of the SUPERSTAR restraint requires replacement (with the exception of the replaceable pad), the entire system must be replaced.

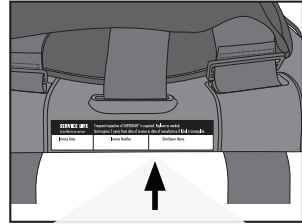

SERVICE LIFE		
Frequent inspection of SUPERSTAR is required. Replace as needed.		
Unit expires 7 years from date of invoice or date of manufacture if label is incomplete.		
Invoice Date	Invoice Number	Distributor Name

**Label must be filled out completely.**

**Figure 2**

### SUPERSTAR In a School Bus Crash

If a school bus is involved in a moderate or severe crash, the entire SUPERSTAR restraint must be replaced regardless if the SUPERSTAR was occupied for use at the time of the crash. Reference the NHTSA Position Paper “**Re-Use of Child Restraint Systems In School Buses After Minor Crashes**” for more information on this matter. This document can be found on the NHTSA.gov website.

### SUPERSTAR Restraint Inspection

1. Inspect harness webbing on entire system for cuts, fraying, or extreme or unusual wear. Most common areas of belt wear include the buckle/latch area and any place where the restraint makes contact with the vehicle seat.  
Corrective action – Replace entire SUPERSTAR restraint.
2. Inspect latch and buckle for proper operation by inserting the latch into the buckle. Latch must insert smoothly, and you must hear an audible click. Verify proper latching by tugging on the belt. Latch must not be worn, deformed or corroded. Buckle must not be damaged, cracked or broken.  
Corrective action – Replace entire SUPERSTAR restraint.
3. Inspect the seat belt height adjuster for damage. Move adjuster up and down. It must move freely and should not be damaged, cracked or broken.  
Corrective action – Replace entire SUPERSTAR restraint.
4. Inspect dual cam wrap system for cuts, fraying, or extreme or unusual wear.  
Corrective action – Replace entire SUPERSTAR restraint.
5. Inspect chest clips for damage and operation. Chest clip halves should not be damaged, cracked or broken. Clips should engage and disengage smoothly with each other. Move clip halves up and down. They must move freely.  
Corrective action – Replace entire SUPERSTAR restraint.
6. Inspect central adjust web and adjuster for cuts, fraying, or extreme or unusual wear.  
Corrective action – Replace entire SUPERSTAR restraint.

## Accessories

For the parts listed below, please contact SafeGuard at 877-447-2305.

### Chest Strap - Optional

Provides postural support for children with special needs.

### Connector Strap

Allows the positioning of three standard SUPERSTAR restraints on a 39" school bus seat.

Connector Strap



## **⚠ WARNING! DEATH or SERIOUS INJURY can occur:**

- Multiple SUPERSTAR units may be used on a single seat but the combined weight of passengers should never exceed 180 lbs.

### Replacement Cover

If the cover becomes overly soiled or damaged, please contact your original place of purchase or contact SafeGuard directly to order a replacement.

## Federal Safety Standards

The SafeGuard SUPERSTAR restraint is certified to applicable U.S. Federal Motor Vehicle Safety Standard FMVSS 213 and 302.

**SafeGuard** 

safeguardseat.com

18881 IMMI Way | Westfield, IN 46074