

# SINK MATE PLUS

## INSTALLATION

### *Mounting the unit*

- (1) Choose a mounting location within easy reach of the sink. Make sure the Sink Mate is at least 12 inches above the chemical supply container(s).
- (2) Remove the cover of the unit as the mounting holes are behind the cover.
- (3) Hold the unit against the wall and mark keyholes — use a level for marking holes.
- (4) Drill holes and install mounting anchors and screws (supplied).
- (5) Hang the unit and tighten screws.
- (6) When reattaching the cover, be sure that the knobs line up properly with the tabs on the water valves and that the dials (if used) are properly aligned.

### *Connecting the water supply*

This proportioner operates best with a flowing water pressure of 30 - 60 PSI. Fluctuating pressure can affect dilution ratios — use a water source that is not feeding other equipment whenever possible. Water temperature should be between 40°F and 140°F.

- (1) Attach male end of high pressure supply hose to inlet side of proportioner using a garden hose washer. Water inlet can be located on the left side if necessary.
- (2) Attach female connector on high pressure hose to water source.
- (3) Turn on water and check for possible leaks.

### *Tubing connections*

- (1) For 1 product units: Route the outgoing 3/4" vinyl tube up through the bottom of the unit and connect to the bottom of the mixing valve assembly. Flex-Gap equipped units have a "flow restrictor" inside the 3/4" tube — connect the tube so that the end with the flow restrictor is closest to the valve.

For 2 product units: A long 3/4" output hose is included so you can cut into needed lengths (many installations have one nearby sink tub, and the other is farther away). Flex-Gap equipped units have a "flow restrictor" inside both ends of the 3/4" tube. Cut the tube into the 2 lengths required for your installation, making sure that the end with the flow restrictor (if used) will be closest to the valve. Route the tubes up through the bottom of the unit and connect to the bottom of the mixing valve assemblies.

- (2) Route the discharge end of the 3/4" vinyl tube(s) to the sink, securing the tube(s) to the wall with the provided tie wraps (they have an "eyelet" for mounting hardware). Cut off any excess tube length not needed.
- (3) For 1 product units: Cut the 3/8" suction tube to a suitable length — the tube must reach from metering tip to bottom of chemical container.

For 2 product units: A long 3/8" suction tube is included with the unit. so you can cut into needed lengths. Cut the tube into the 2 lengths required for your installation — the tubes must reach from metering tips to bottom of chemical containers.

- (4) Insert the appropriate metering tip into the valve(s) — see the following page for tip selection.
- (5) Route the suction tube(s) up through the bottom of the unit and slide the tube(s) over the metering tip. Secure in place with a tie wrap.
- (6) Slide a ceramic weight onto the pickup end of the suction tube, then insert a footvalve into the tube.
- (7) Drop the suction tube(s) into the chemical container(s), ensuring that the ceramic weight pulls the footvalve(s) down to the bottom of the container(s).

## OPERATION

Turn the "T" handle clockwise to open the valve, and counter-clockwise to close it. Valve is open when the handle is vertical and closed when the handle is horizontal. Check all connections for leaks and verify that chemical is being pulled up suction line. Make any necessary adjustments and the unit is then ready to go!

## METERING TIP SELECTION

The chart below is based upon the chemical viscosity of water (CPS = 1.0) and should only be used as a guide. Actual ratios and flow rates may vary due to product viscosity, flow pressure, and tubing distance. To easily calculate the actual ounces per gallon for a specific product:

- (1) Fill graduated cylinder or spray bottle (that has ounce markings) with product.
- (2) Install metering tip closest to desired ounces per gallon from chart.
- (3) Drop chemical pick-up tube into the container holding the product.
- (4) Activate valve until chemical line is primed up to the metering tip.
- (5) Note how many ounces of product are in the container.
- (6) Activate valve again, filling a one gallon jug with water/product mix.
- (7) Note how many ounces of product were used — this is your actual ounce per gallon ratio.

METERING TIP CHART (Flex-Gap & Aire-Gap Venturi)				
TIP COLOR	1 GPM		4 GPM	
	OZ/GAL	RATIO	OZ/GAL	RATIO
NO INSERT				
WHITE	30.00	4.3:1	14.00	9.1:1
YELLOW	29.00	4.4:1	13.00	9.8:1
PINK	27.00	4.7:1	11.00	11.6:1
GREEN	24.00	5.3:1	9.00	14.2:1
BLACK	20.00	6.4:1	7.00	18.3:1
BROWN	14.00	9.1:1	5.00	25.6:1
GRAY	10.00	12.8:1	4.00	32.0:1
BLUE	8.00	16.0:1	3.00	42.7:1
RED	6.00	21.3:1	2.00	64.0:1
PEACH	5.00	25.6:1	1.50	85.3:1
LT BLUE	4.00	32.0:1	1.25	102.4:1
PURPLE	3.00	42.7:1	1.00	128.0:1
LT GREEN	2.00	64.0:1	0.75	170.7:1
ORANGE	1.00	128.0:1	0.50	256.0:1
LT BROWN	0.50	256.0:1	0.25	512.0:1



**CAUTION: Wear protective clothing and eyewear when dispensing chemicals or other materials. Observe safety handling instructions (MSDS) of chemical mfrs.**



**CAUTION: When installing any equipment, ensure that all national and local safety and plumbing codes are met.**

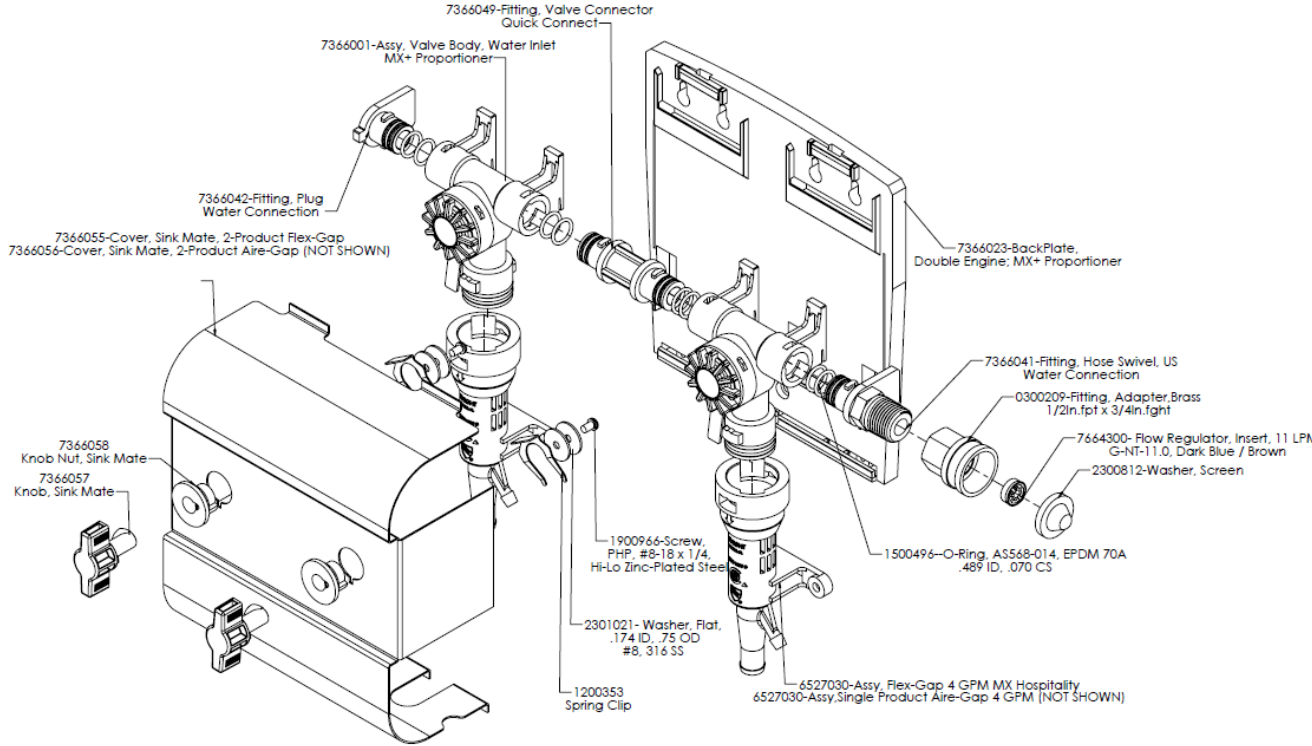
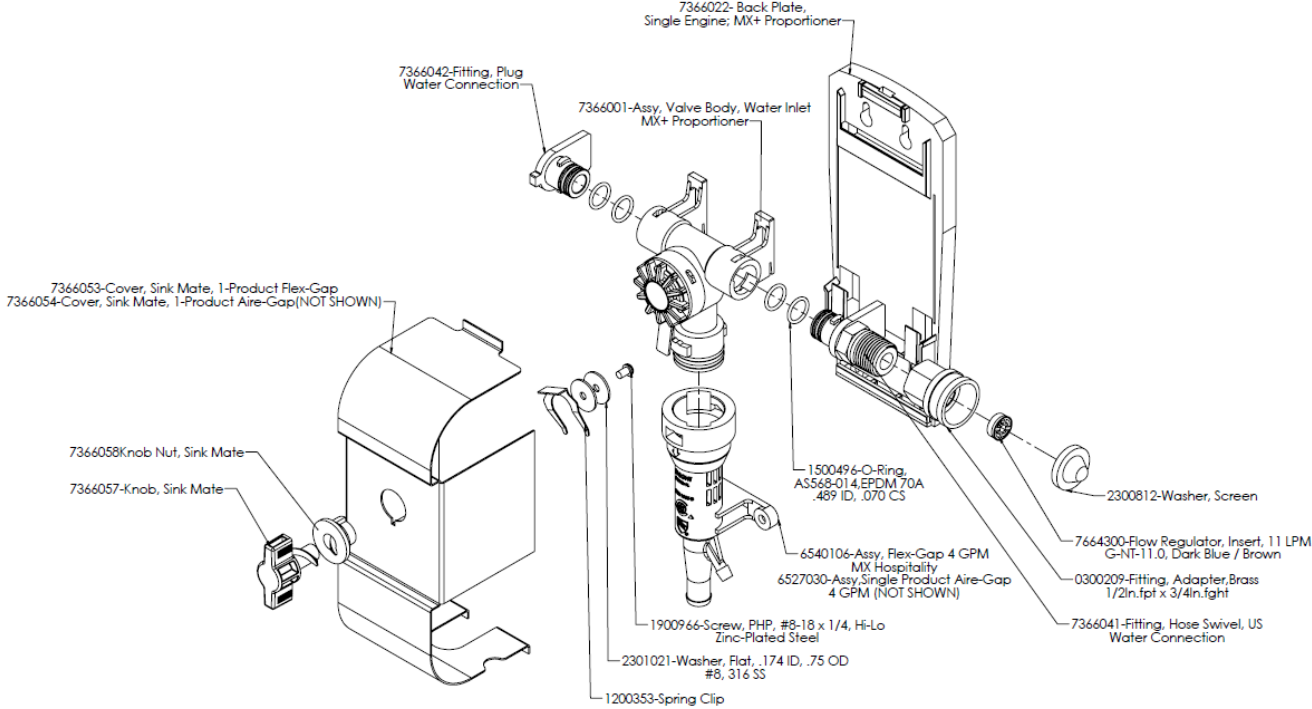

## FLEX-GAP ANNUAL CLEANING AND TEST PROCEDURES FOR UNITS INSTALLED IN CANADA

---

Each year, your chemical dispenser must be cleaned and its backflow prevention performance verified. As this device is an end-of-line device (versus an in-line device) and evidence of effective backflow prevention is determined visually, a two-minute pressure test is not necessary.

If the Flex-Gap device cannot readily be seen during the test procedure, the housing of the chemical dispensing unit must be removed during testing. Apply the appropriate test procedure below as applicable for your chemical dispensing unit.

### 4 GPM VENTURIS

1. Fill discharge hose with water by opening the valve.
2. When water begins to exit the discharge hose turn off the water and raise the end of the hose above the Flex-Gap.
3. Observe that water is exiting the Flex-Gap.
4. If the water is exiting the Flex-Gap it has passed the test.
5. If the water is not exiting from the Flex-Gap, replace the Flex-Gap sleeve as per the instruction manual and re-test.
6. If the water is not exiting from the Flex-Gap after replacing the sleeve and re-testing, replace the complete Flex-Gap assembly and re-test.
7. If the water is not exiting from the Flex-Gap after replacing the Flex-Gap assembly, disconnect the water supply and replace the complete unit.

### 1 GPM VENTURIS

1. Remove the Fill Tube Spout and replace with a 4-foot length of 1/2" ID hose.
2. Fill the discharge hose with water by opening the valve.
3. When water begins to exit the discharge hose, turn off the water and raise the end of the hose above the Flex-Gap.
4. Observe that water is exiting the Flex-Gap.
5. If the water is exiting the Flex-Gap, it has passed the test.
6. If the water is not exiting from the Flex-Gap, replace the Flex-Gap sleeve and re-test.
7. If the water is not exiting from the Flex-Gap after replacing the sleeve and re-testing, replace the complete Flex-Gap assembly and re-test.
8. If the water is not exiting from the Flex-Gap after replacing the Flex-Gap assembly, disconnect the water supply and replace the complete unit.

---

## DISCLAIMER

Knight LLC does not accept responsibility for the mishandling, misuse or non-performance of the described items when used for purposes other than those specified in the instructions. For hazardous materials information consult label, MSDS, or Knight LLC.

## WARRANTY

For complete product terms and conditions scan the QR code at right or enter the following URL into your browser: <http://cfstech.info/t-and-c>

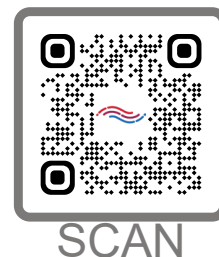

KNIGHT LLC is part of the CFS Technologies family of brands.

[www.knightequip.com](http://www.knightequip.com) | [cfstech.com](http://cfstech.com)

8504 MacArthur Dr., North Little Rock, AR 72118 USA • 501-895-2820 | 800-999-2820

General: [sales@cfstech.com](mailto:sales@cfstech.com) | Tech. Assist.: [techsupport@cfstech.com](mailto:techsupport@cfstech.com)