

### GENERAL

|                     |               |
|---------------------|---------------|
| Nominal Voltage     | 51.2V         |
| Working Voltage     | 43.2V - 58.4V |
| Recommended Voltage | 48.0V - 57.0V |
| Cell Count          | 32            |
| Nominal Capacity    | 160Ah         |
| Energy              | 8,192Wh       |
| Reserve @25A        | 384 Minutes   |
| Self Discharge      | 1% Per Month  |
| IP Rating           | IP67          |

### CHARGING

|                         |              |
|-------------------------|--------------|
| Recom. Charging Current | <80A         |
| Max Charging Current    | 160A         |
| Bulk/Absorb Voltage     | 57.0V        |
| Float Voltage           | 54.0V or Off |
| BMS High Voltage Cutoff | 59.2V        |
| Charging Temp. Range    | 32F to 130F  |

### DISCHARGING

|                          |              |
|--------------------------|--------------|
| Max Continuous Discharge | 175A         |
| Max Discharge 3 Sec      | 500A         |
| Max Discharge 30 Sec     | 300A         |
| Recom. Voltage Cutoff    | 48.0V        |
| BMS Voltage Cutoff       | 43.2V        |
| BMS Voltage Recovery     | 46.4V        |
| Discharge Temp Range     | -10F to 140F |

### COMMUNICATION

|           |     |
|-----------|-----|
| Bluetooth | Yes |
| CAN       | Yes |



### SAFETY

|                            |                     |
|----------------------------|---------------------|
| Charging Freeze Protection | Yes, Under 32F      |
| Pack Over-Voltage          | Yes                 |
| Cell Balancing             | Yes                 |
| Pack Under-Voltage         | Yes                 |
| Cell Under-Voltage         | Yes                 |
| Cell Over-Temp             | Yes                 |
| BMS Over-Temp              | Yes                 |
| Short Circuit/Over Current | Yes                 |
| Certifications             | UN38.3, UL1642 Cell |

### PHYSICAL

|                      |                        |
|----------------------|------------------------|
| Cell Chemistry       | Lithium Iron Phosphate |
| Cell Type            | Prismatic              |
| Cell Configuration   | 2P16S                  |
| Series Connectable   | No                     |
| Parallel Connectable | Yes, up to 2           |
| Weight               | 146 lbs (66.22Kg)      |
| Dimension LxWxH      | 22"X12.125"X10.625"    |
| Terminal Type        | M8 Female              |
| Shell Type           | Powder Coated Steel    |
| UN Shipping Class    | UN 3480                |

**DIMENSIONS**

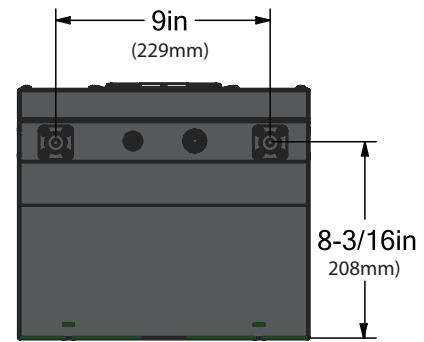

**Torque Specs**

**M8 Terminal Bolts**  
**6ft/lbs (72 in/lbs)**

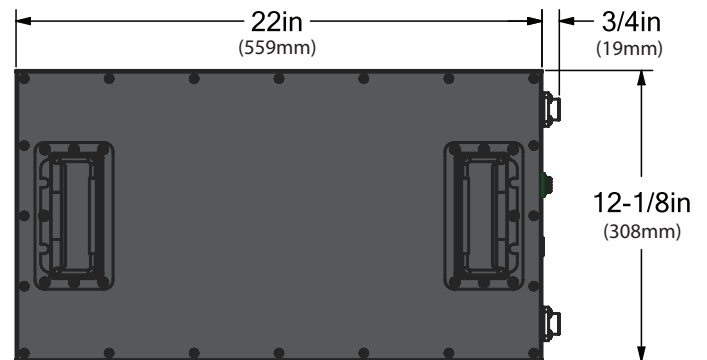

**Voltage Curve**

