

Y-CLEVIS Y-CLEVIS LINK

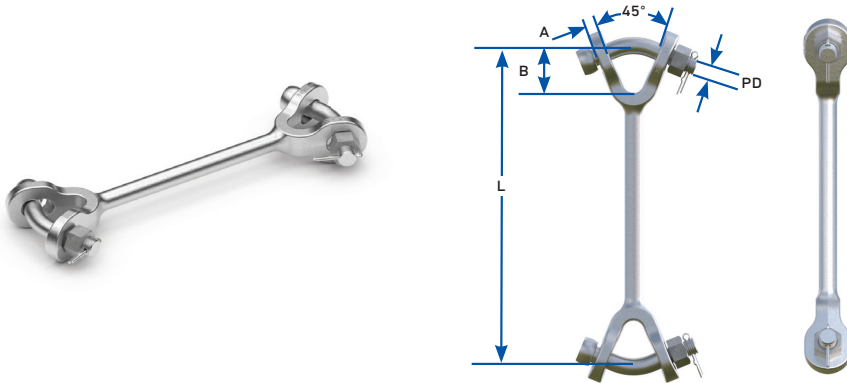

Component	Material
Body	Ductile Iron, Hot Dip Galvanized
Hardware	Galvanized Steel
Cotter Pin	Stainless Steel

Catalog Number	General Dimensions				Vertical Ultimate Strength lbf (kN)
	in (mm)				
	A	B	L	PD	
YCYC-30-L	19/32 (15)	1-1/2 (38)	TBD	3/4 (19)	30,000 (133)
YCYC-50-L	3/4 (19)	1-27/32 (47)	15-1/32 (382)	7/8 (23)	50,000 (222)

CLEVIS EYE LINK – 30 K

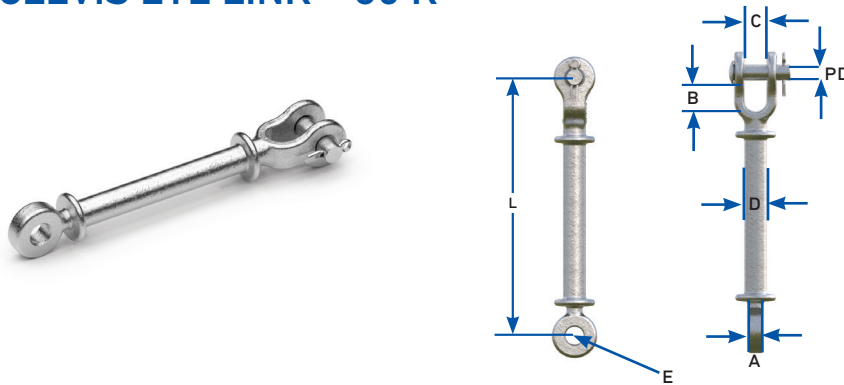

Component	Material
Body	Ductile Iron, Hot Dip Galvanized
Hardware	Galvanized Steel
Cotter Pin	Stainless Steel

Catalog Number	General Dimensions							Vertical Ultimate Strength lbf (kN)	Weight lb (kg)
	in (mm)								
	A	B	C	D	E	L	PD		
CEL-30-10	5/8 (15.9)	1-3/16 (30.2)	13/16 (20.6)	7/8 (22.3)	11/16 (17.5)	10 (254)	5/8 (15.9)	30,000 (133)	2.6 (1.2)

For bolt, nut, and cotter in place of clevis pin and cotter, add BNK to the catalog number
 For 90 degree rotation, add a "-90" to the end of the part number (Ex: CEL-30-10-90).