



COMPRESSION DEAD-END & JUMPER TERMINAL

FOR ACCC® & ULS ACCC INFOCORE® CONDUCTORS

INSTALLATION INSTRUCTIONS



IMPORTANT SAFETY INFORMATION

READ AND COMPLETELY UNDERSTAND ALL INSTRUCTIONS BEFORE INSTALLING PRODUCT. FAILURE TO FOLLOW THESE INSTRUCTIONS MAY RESULT IN PERSONAL INJURY OR DEATH.

This product is intended for use by trained technicians only. This product should not be used by anyone who is not familiar with and not trained to use it. When working in the area of energized lines, extra care should be taken to prevent accidental electrical contact. Be sure to wear proper safety equipment per your company protocol. These instructions are not intended to supersede any company construction or safety standards. These instructions are offered only to illustrate safe installation for the individual. PLP products are intended for the specified application only. Do not modify this product under any circumstances. Do not reuse or reinstall any PLP product unless that capability is expressly indicated in the product's Installation Instructions. For proper performance and personal safety, be sure to select the proper PLP product before installation. PLP products are precision devices. To ensure proper performance, they should be stored in cartons under cover and handled carefully. No tension should be applied to the conductor until the full completion of this procedure.

TABLE OF CONTENTS

Compression Dead-End.....	2
Jumper Terminal	8
Capping Fitting	10
Complete Dead-End Jumper Terminal Assembly	12

INSTALLATION OVERVIEW

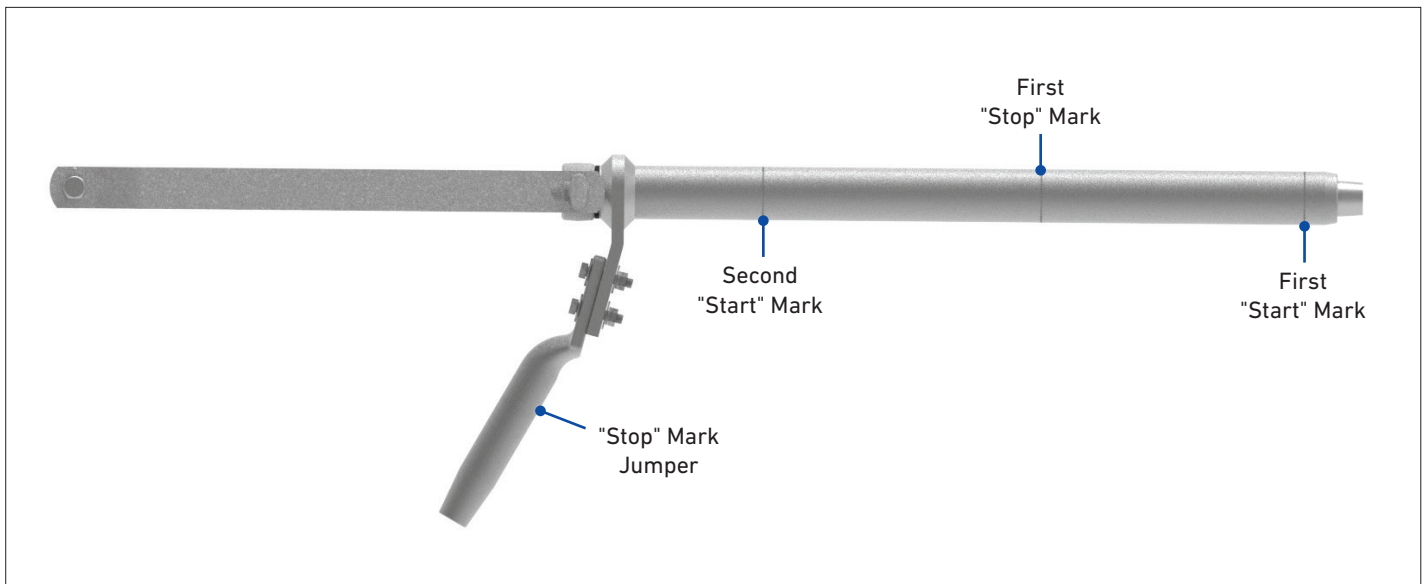

NOTE: The product is imprinted with instructional words, such as "Start" and "Stop" to aid installation.

PRODUCT COMPATIBILITY

These Installation Instructions are valid for PLP ACCC® and ULS ACCC InfoCore® Compression Dead-End Assemblies, Compression Jumper Terminal Assemblies individually, or the Full Compression Dead-End with Jumper Terminal.

PRECAUTIONARY MEASURES

CAUTION

Failure to follow the precautions, notes, and steps contained within these Installation Instructions represents a misapplication of the product. This product and application procedure are for ACCC & ULS ACCC InfoCore conductors.

- (1) Ensure that the correct compression product has been selected for the conductor. Compare catalog numbers of the product with associated conductor size/range published in PLP literature.
- (2) Be certain that the dies being used to compress the fittings match the engraved sizes marked on the product surfaces. The dies will have markings on the surface of the die face or the edges of the die.
- (3) The compression press and the dies **MUST** be inspected before use. Ensure that they are well lubricated; there are no hydraulic oil leaks; the press is of the correct size (60- or 100-Ton) to adequately compress the fittings; die surfaces mate completely when the press is fully extended; and that the dies are in good condition without significant damage or wear.
- (4) Before installation, the mating surfaces of the products to be installed, such as the inner bore of the aluminum tube, the inner bore and outer surfaces of steel hardware, must be inspected for surface imperfections, etc. If any significant irregularities exist, the products **MUST** be discarded or returned to PLP. **DO NOT install defective or damaged compression hardware.**

PACKAGE COMPONENTS

COMPRESSION DEAD-END

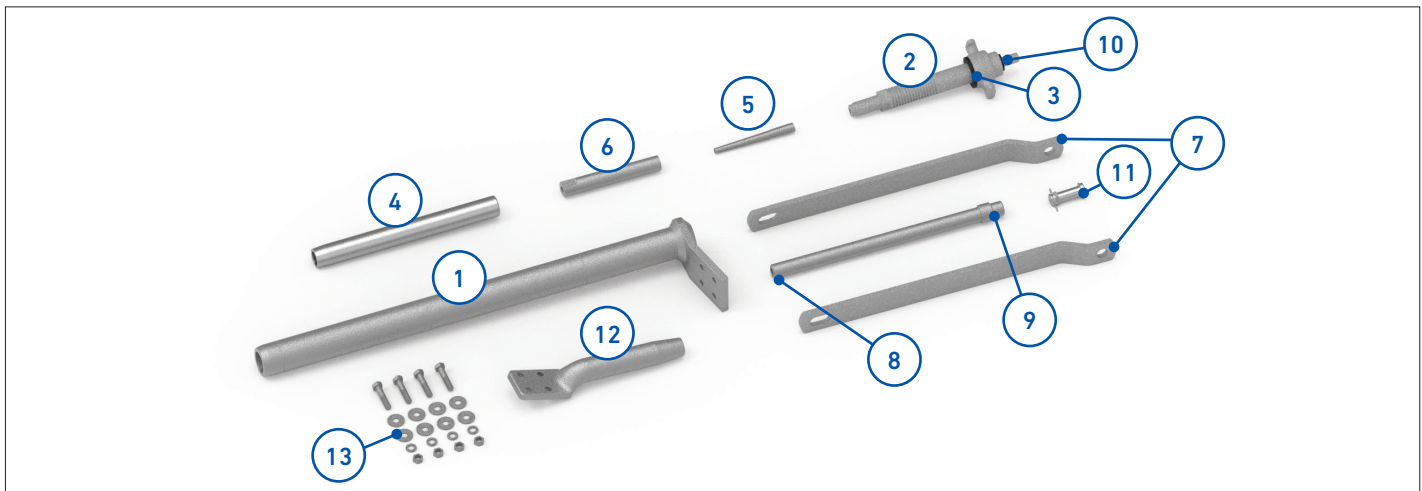

- | | |
|--|----------------------------|
| 1. Aluminum Alloy Dead-End Body | 9. Extension Tube Cap |
| 2. Stainless Steel Alloy Dead-End Body | 10. Extension Tube Seal |
| 3. Seal | 11. Retention Bolt and Nut |
| 4. Dead-End Inner Sleeve | 12. Jumper Terminal |
| 5. Collet | 13. Fastener Kit |
| 6. Housing | (Not shown) |
| 7. Straps | -Jumper Inner Sleeve |
| 8. Extension Tube | -Sand Paper |
| | -Inhibitor |

Tools Required:

- 60- or 100-Ton Press
- Product-Specific Aluminum (AH) Dies
- Torque Wrench
- Large Adjustable Wrench
- File
- Measuring Tape/Caliper
- Utility Knife
- Conductor strippers
- Hacksaw with fine-tooth blade
- Wire brush
- Marker pen
- Tape
- Lubricant or bar soap



ACCC® & ULS ACCC INFOCORE® CONDUCTOR INFORMATION

Small Sizes

USA ACCC Code Name	kcmil	International ACCC Code Name	mm ²	Outside Diameter in (mm)	"A" Exposed Core Length in (mm)*	"B" Approximate Eye Distance in (mm)
	156.5	Skadar	79.3	0.523 (13.2842)	27.87 (708)	1.97 (50)
	221.8	Rijeka	112.4	0.535 (13.589)	27.87 (708)	1.97 (50)
	242.2	Silvassa	122.7	0.565 (14.351)	27.87 (708)	1.97 (50)
Pasadena	297.2	Helsinki	150.6	0.616 (15.6464)	27.87 (708)	1.97 (50)
	307.3	Jaipur	155.7	0.650 (16.51)	27.87 (708)	1.97 (50)
	350.1	Zadar	177.4	0.673 (17.0942)	27.87 (708)	1.97 (50)
	370.6	Rovinj	187.8	0.673 (17.0942)	27.87 (708)	1.97 (50)
Oceanside	383.2		194.2	0.680 (17.272)	27.87 (708)	1.97 (50)
Linnet	430.5	Copenhagen	219.9	0.720 (18.288)	27.87 (708)	1.97 (50)
Oriole	438.6	Reykjavik	223.1	0.741 (18.8214)	27.87 (708)	1.97 (50)
	491.0	Gdansk	248.8	0.756 (19.2024)	27.87 (708)	1.97 (50)
Waco	454.0	Glasgow	236.7	0.770 (19.558)	27.87 (708)	1.97 (50)
Laredo	529.8	Casablanca	273.6	0.807 (20.4978)	27.87 (708)	1.97 (50)
Hawk	611.3	Lisbon	315.5	0.858 (21.7932)	27.87 (708)	1.97 (50)
Dove	713.5	Amsterdam	367.4	0.927 (23.5458)	27.87 (708)	1.97 (50)
	788.2	Cordoba	399.4	0.961 (24.4094)	27.87 (708)	1.97 (50)
Amarillo	784.7	Leipzig	421.4	0.990 (25.146)	27.87 (708)	1.97 (50)
Grosbeak	821.4	Brussels	421.4	0.990 (25.146)	27.87 (708)	1.97 (50)

NOTE: ULS conductors with the same name will be built to the same process as the standard conductors above.

*Add 250 mm to Length "A" if test equipment is for InfoCore V1.

Medium Sizes

USA ACCC Code Name	kcmil	International ACCC Code Name	mm ²	Outside Diameter in (mm)	"A" Exposed Core Length in (mm)*	"B" Approximate Eye Distance in (mm)
	451.0	Monte Carlo	228.5	0.818 (20.777)	34.06 (865)	1.57 (40)
Irving	609.5	Oslo	313.8	0.882 (22.403)	34.06 (865)	1.57 (40)
Lubbock	903.9	Stockholm	453.7/463.3	1.040 (26.416)	34.06 (865)	1.57 (40)
Galveston	1011.3	Warsaw	507.5	1.090 (27.686)	34.06 (865)	1.57 (40)
Drake	1025.6	Dublin	524.5	1.108 (28.1432)	34.06 (865)	1.57 (40)
	1072.6	Kolkata	543.5	1.127 (28.6258)	34.06 (865)	1.57 (40)
Curlew	1033.0	Mahakam	544.9	1.140 (28.956)	34.06 (865)	1.57 (40)
Plano	1059.5	Hamburg	546.5	1.127 (28.6258)	34.06 (865)	1.57 (40)
Corpus Christi	1103.0	Milan	567.7	1.146 (29.1084)	34.06 (865)	1.57 (40)
Arlington	1151.1	Rome	592.5	1.177 (29.8958)	34.06 (865)	1.57 (40)
Cardinal	1221.8	Vienna	629.2	1.198 (30.4292)	34.06 (865)	1.57 (40)
Fort Worth	1300.4	Budapest	668.3	1.240 (31.496)	34.06 (865)	1.57 (40)
	1352.7	Mumbai	685.4	1.251 (31.7754)	34.06 (865)	1.57 (40)
El Paso	1349.9	Prague	690.7	1.251 (31.7754)	34.06 (865)	1.57 (40)
	1386.0	Ratchaburi	702.4	1.257 (31.93)	34.06 (865)	1.57 (40)
Beaumont	1427.6	Dhaka	723.9	1.294 (32.8676)	34.06 (865)	1.57 (40)
	1447.0	Munich	733.2	1.293 (32.8422)	34.06 (865)	1.57 (40)
San Antonio	1474.9	London	759.0	1.315 (33.401)	34.06 (865)	1.57 (40)
Bittern	1581.6	Paris	813.7	1.345 (34.163)	34.06 (865)	1.57 (40)

NOTE: ULS conductors with the same name will be built to the same process as the standard conductors above.

*Add 250 mm to Length "A" if test equipment is for InfoCore V1.

ACCC® and InfoCore® are registered trademarks of CTC Global, Inc.

ACCC® & ULS ACCC CONDUCTOR INFORMATION CONTINUED

Large Sizes

USA ACCC Code Name	kcmil	International ACCC Code Name	mm ²	Outside Diameter in (mm)	"A" Exposed Core Length in (mm)*	"B" Approximate Eye Distance in (mm)
Dallas	1794.9	Antwerp	944.9	1.452 (36.8808)	34.06 (865)	1.57 (40)
Houston	1927.4	Berlin	1006.6	1.504 (38.2016)	34.06 (865)	1.57 (40)
Lapwing	1948.9	Madrid	1013.1	1.506 (38.2524)	34.06 (865)	1.57 (40)
Falcon	2045.1		1036.3	1.545 (39.243)	34.06 (865)	1.57 (40)
Chuckar	2241.5		1135.8	1.604 (40.7416)	34.06 (865)	1.57 (40)
Bluebird	2740.6	Athens	1409.8	1.762 (44.7548)	34.06 (865)	1.57 (40)

NOTE: ULS conductors with the same name will be built to the same process as the standard conductors above.

*Add 250 mm to Length "A" if test equipment is for InfoCore® V1.

NOTE: NO TENSION SHOULD BE APPLIED TO THE CONDUCTOR UNTIL THE FULL COMPLETION OF THIS PROCEDURE.

DEAD-END ASSEMBLY APPLICATION

- Starting from the end, measure and mark the conductor according to the "Exposed Core Length" column A in the provided table on pages 3 and 4.

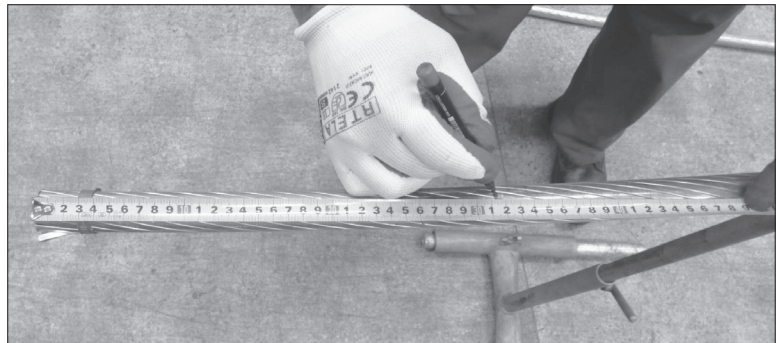

- Apply tape approximately 1" (25 mm) back from the mark to secure the aluminum strands and maintain the conductor diameter after the cut is made.

- Cut the outer strands at the strand mark to expose the composite core.

CAUTION

Be careful not to cut or damage the core. Ensure that the core end is not crushed. Failure to follow these instructions could result in a poor connection. PLP recommends using a conductor trimming tool for this step.



- Wipe the outer surface of the core clean and free of oil with a cloth. Use the provided 220-grit sandpaper to lightly rub the core to remove the shine or gloss. Rewipe the core with a clean cloth.



- 5 Clean/wire-brush the entire aluminum area to be covered by the compression hardware and outside of the inner sleeve. Check that no residue or surface particles remain.

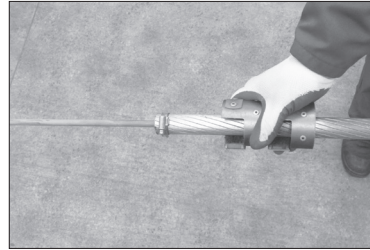

- 6 Apply the supplied oxide inhibitor (grease) to the aluminum strands to be covered by the compression hardware.

CAUTION

Only use the supplied oxide inhibitor. Use of any unqualified product may affect function.

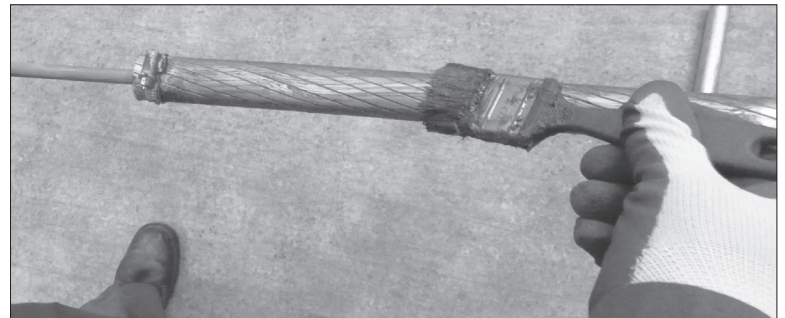

- 7 With the tapered end of the inner aluminum sleeve facing the end of the conductor, slide it approximately 3 ft (1 m) onto the conductor.

NOTE: To keep the strands tight during assembly of the filler tube, rotate the tube in the direction of the lay of the strand.



- 8 Apply the oxide inhibitor (grease) to the surface of the inner aluminum sleeve, excluding the tapered section.

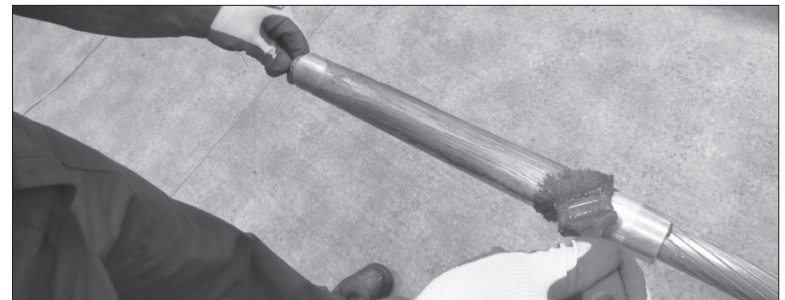

- 9 Slide the outer aluminum tube over the conductor toward the inner aluminum sleeve.

NOTE: DO NOT slide the outer aluminum tube past the inner aluminum sleeve.

- 10 Using a felt tip marker, make a mark on the core 3" (76 mm) from the end of the aluminum strands.



- 11** Slide the collet housing onto the core, with the wrench flats facing the conductor. Then slide the collet, with the narrow end facing the collet housing, onto the core until the edge reaches the 3" (76 mm) mark. A minimum of 1/4" (6 mm) of the core must be exposed through the back of the collet.

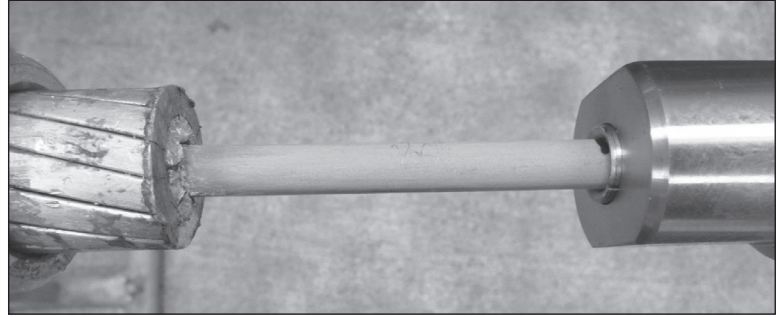

- 12** Ensure that the seal is present on the steel eye/clevis. Then screw the steel eye/clevis into the collet housing until hand-tight. Then, while holding the collet housing steady, use a torque wrench to fully tighten to a minimum of 85 ft-lb (115 Nm). Check the location of the collet and ensure that approximately 3" (76 mm) of the core is exposed. Avoid skewing the conductor core to prevent damage.

NOTE: Install the extension tube before threading the steel eye onto the housing (protects the exposed core).

NOTE: DO NOT torque the housing. Hold the housing with the wrench while torquing the steel eye/clevis.

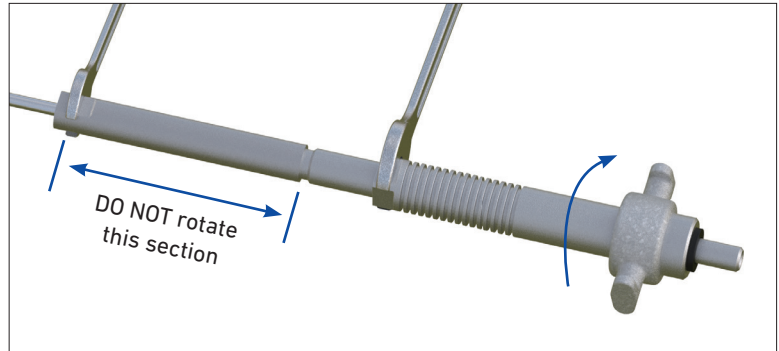

- 13** Slide the outer aluminum tube towards the eye, lining up the edge of the pad with the mark on the steel eye/clevis. If no mark is present, offset the steel eye/clevis to the dimension in the table in column B, "Approximate Eye Distance" on page 3.

NOTE: This distance can vary ± 0.20 " (5 mm); the installer may adjust after the first complete compression assembly.

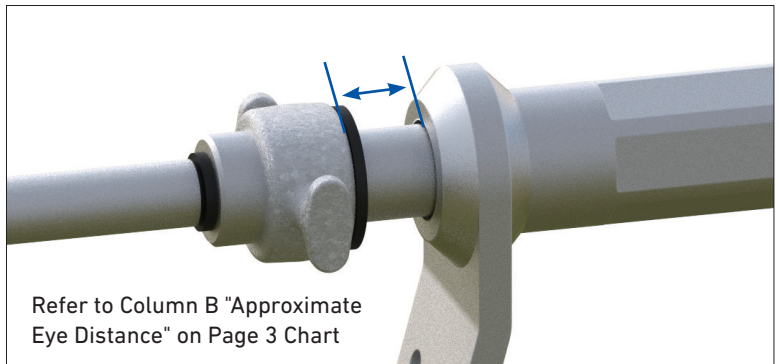

- 14** Position the inner aluminum sleeve so that 1" (25 mm) is sticking out of the outer aluminum tube.

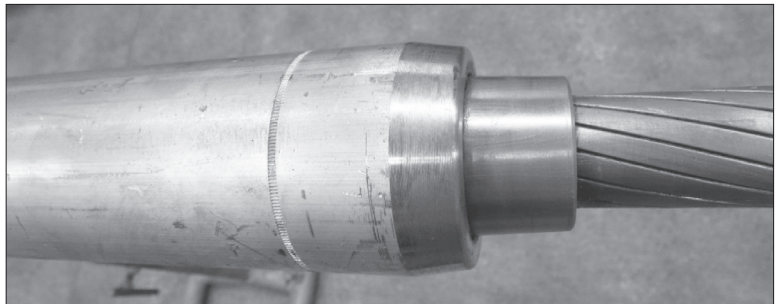

15

Ensure that the compression die surfaces are clean and free of burrs or debris. Either lubricate the compression dies with a wet lubricant or apply a dry lubricant to the compression surface of the components. After verifying that the correct die size is being used, begin compressing the outer aluminum tube at the opposite end of the eye/ clevis at the "Start" knurl.

CAUTION

Clean dies and sufficient, but not excessive, lubrication are the most important factors in applying proper compressions and avoiding curvature.

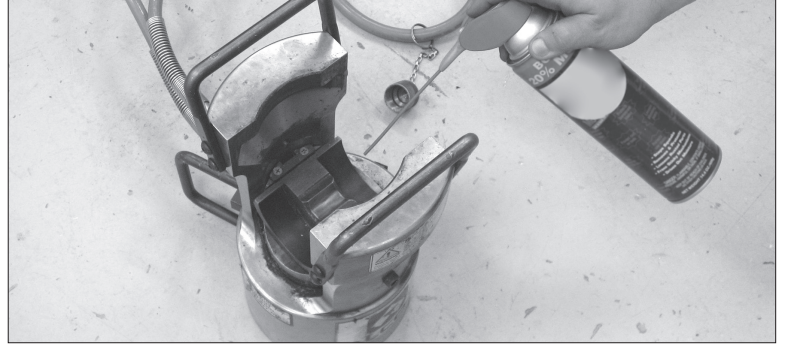
16

Overlap compressions by 1/4 to 1/2 of their lengths in the direction of the eye to ensure compression. Continue until the compressions meet the first stop mark on the outer tube.

NOTE: For the first fitting assembled, PLP recommends measuring the gap from step 13 one compression 1-1/2" (37 mm) before reaching the First Stop Mark:

(A) If the gap is less than 1/4" (6 mm) do not make the last compression (blue area), proceed to the second "Start" mark and compress until seal is set.

(B) If the gap is greater than 1/2" (13 mm) make two more compressions (blue and green area) before proceeding to the second "Start" mark.

(C) If the gap is between 1/4" and 1/2" (6 - 13 mm) make the last compression then proceed to the second "Start" mark.

If either adjustment has to be made with the first fitting assembled, the subsequent fitting's "B" distance should be adjusted to: (A) increase by 2 mm or (B) decrease by 2 mm.

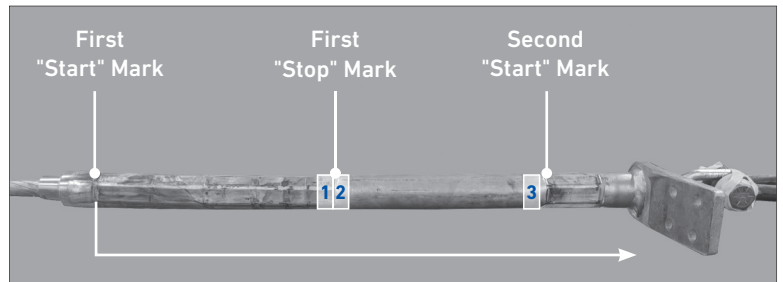
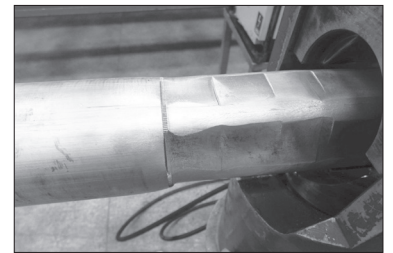
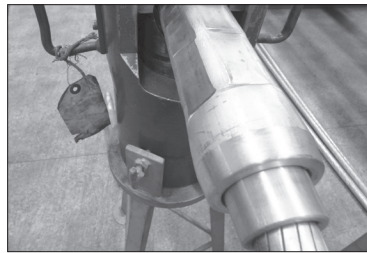
17

Start second compression at the second "Start" knurl (as shown in Step 16) and compress towards the steel eye/clevis. Continue compressions towards the eye or clevis until the seal is compressed (if the second "Stop" mark is present, it is okay to compress beyond it to seat the seal. Do not over-compress the seal.

NOTE: The measured gap between the seal and clevis head is greater than 1/4" (7 mm), start compression 1" (25 mm) over the second "Start" mark (area #3 in Step 16).

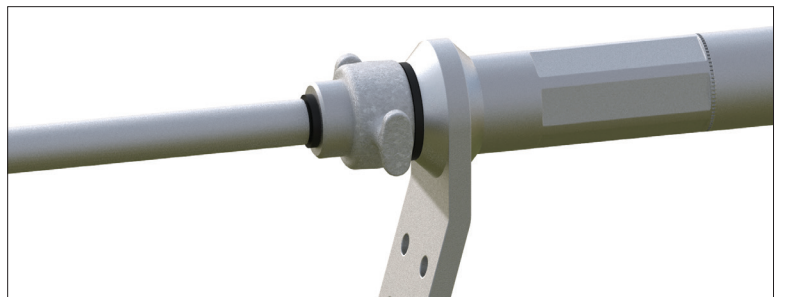

PACKAGE COMPONENTS

JUMPER TERMINAL

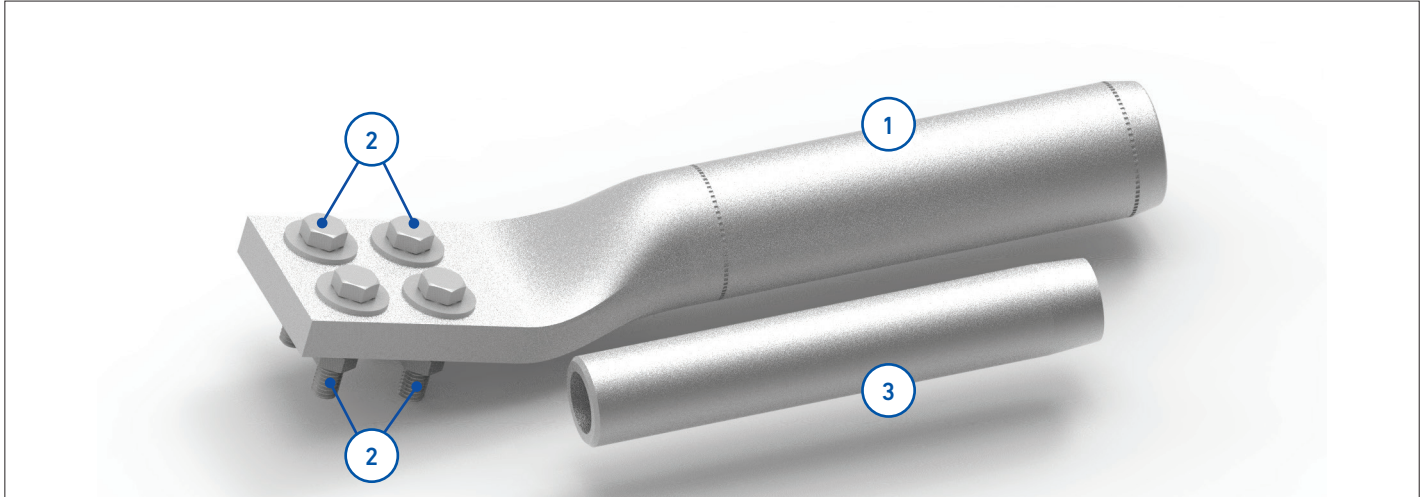

1. Aluminum Alloy Jumper Terminal
2. Fastener Kit
3. Inner Sleeve

Tools Required:

- 60- or 100-Ton Press
- Product-Specific Aluminum (AH) Dies
- Filler Compound (Rated for Application)
- Caulking Gun
- File
- Measuring Tape
- Utility Knife
- Wire brush
- Torque wrench
- Wrench or socket wrench

JUMPER TERMINAL APPLICATION

- 1 Clean/wire-brush the entire aluminum area to be covered by the compression hardware and outside of the inner sleeve. Ensure that no residue or surface particles remain.



- 2 Apply the supplied oxide inhibitor (grease) to the aluminum strands to be covered by the compression hardware.



- 3 With the tapered end of the inner aluminum sleeve facing the conductor, slide it down until the non-tapered end lines up with the end of the conductor.

NOTE: To keep the strands tight during assembly of the filler tube, rotate the tube in the direction of the lay of the strand.

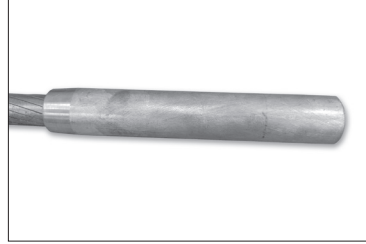

- 4 Apply the supplied oxide inhibitor (grease) to the outside of the inner aluminum sleeve, excluding the tapered portion.



- 5 Slide the jumper terminal onto the inner aluminum sleeve such that 1" (25 mm) of the inner aluminum sleeve is sticking out.

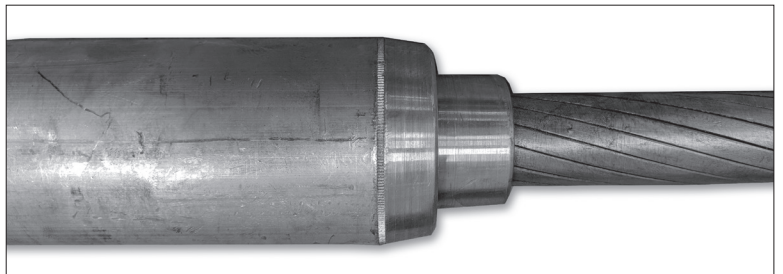

- 6 Ensure that the compression die surfaces are clean and free of burrs or debris. Either lubricate the compression dies with a wet lubricant or rub a dry lubricant onto the component's compression surface. After verifying that the correct die size is being used, begin compressing the outer aluminum tube at the opposite end of the eye/clevis at the "Start" knurl.

CAUTION

Clean dies and sufficient but not excessive lubrication are the most important factors in applying proper compressions and avoiding curvature.

- 7 Begin compressions on the jumper terminal inside the knurl on the end opposite the jumper pad. Overlap compressions by 1/4 to 1/2 of their length in the direction of the jumper pad to ensure complete compression.

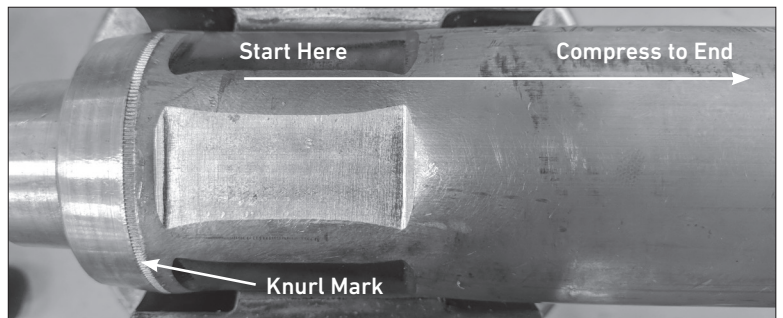

- 8 Continue to compress until the compressions meet the inside of the knurl closest to the jumper pad.



CAPPING FITTING

This section of the Installation Instructions is specific to how the end user plans to utilize the InfoCore® system. The "A" application method is for capping before installation in the tower, whereas the "B" application method is for capping after installation in the tower.

ASSEMBLY METHOD A FOR INFOCORE V1 MEASUREMENT EQUIPMENT

InfoCore measurement after assembly of fitting (last measurement after fitting has been installed, but before installing the conductor assembly in the tower).

- 1 Measure according to the CTC Global InfoCore inspection procedure. After completing a successful InfoCore measurement, trim the core extending through the end of the steel fitting flush with the steel fitting and install the large seal.

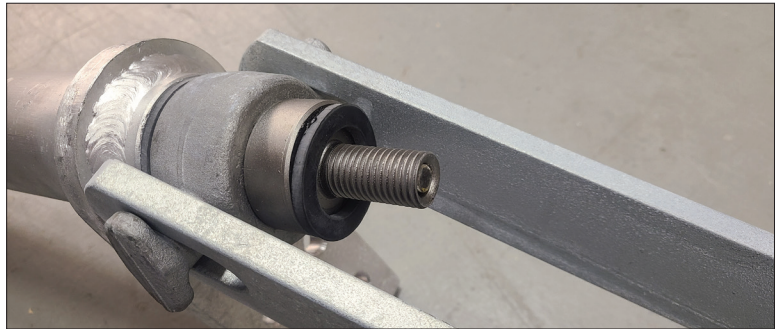

- 2 Remove the black core protector/seal from the stepped aluminum cap.



- 3 Thread down the aluminum cap until snug, then apply an additional 1/4 turn using a wrench.

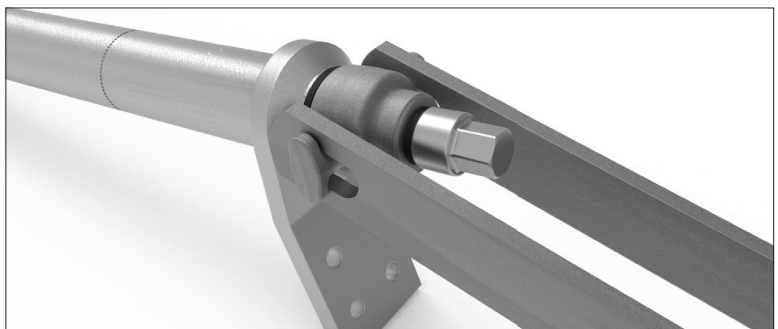

ASSEMBLY METHOD B FOR INFOCORE V2 MEASUREMENT EQUIPMENT

InfoCore® measurement after the conductor assembly is installed in the tower.

1

Measure according to the CTC Global InfoCore inspection procedure. After completing a successful InfoCore measurement, slip the large seal and aluminum core protector tube over the exposed core and snug them into place.

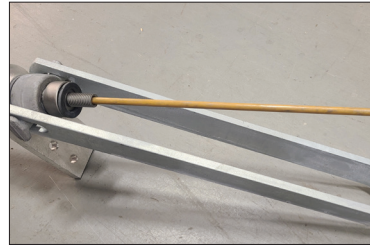

2

Install the conductor line assembly in the tower.

NOTE: It is okay to grab the fitting assembly by the installed core protector tube.

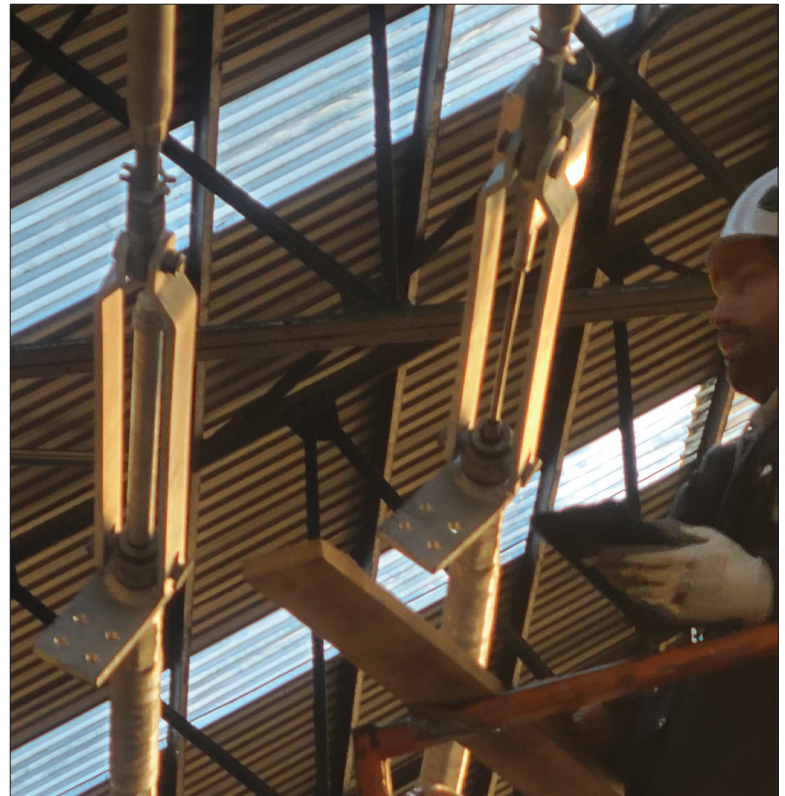

3

Remove the aluminum core protector tube, and measure according to the CTC Global InfoCore inspection procedure.



- 4 After completing a successful InfoCore measurement, reinstall the protector tube and the stepped aluminum cap.



PACKAGE COMPONENTS

DEAD-END JUMPER

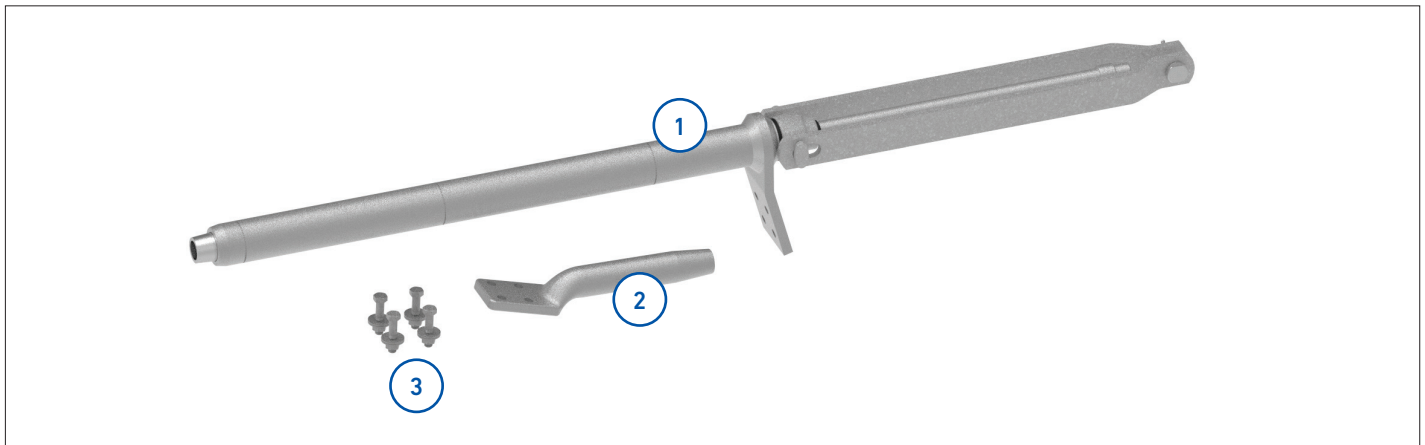

1. Dead-End Assembly
2. Jumper Terminal
3. Hardware

Tools Required:

- Torque Wrench
- Wrench
- Joint Compound (not included)

DEAD-END JUMPER ASSEMBLY

- 1 Check that the pad connections are free from damage and residue. Thoroughly clean the pads of both the dead-end and the jumper terminal with a wire brush to remove any oxidation.



- 2 Coat the dead-end terminal pad with conductive electrical joint compound (not included). Spread the compound evenly over the pad to ensure total coverage.

CAUTION

DO NOT use inhibitor (grease) compound that is used to coat the inner hardware before compressions.



- 3 Place a flat washer onto each bolt and thread through the pad. On the opposite side, apply the other flat washer, then lock washer, then nut, and hand-tighten. Once tight, torque the bolts to at least 40 ft-lb (54 Nm), revisiting each bolt several times to ensure that the pad is fully compressed and that all bolts are tightened to the proper specification.

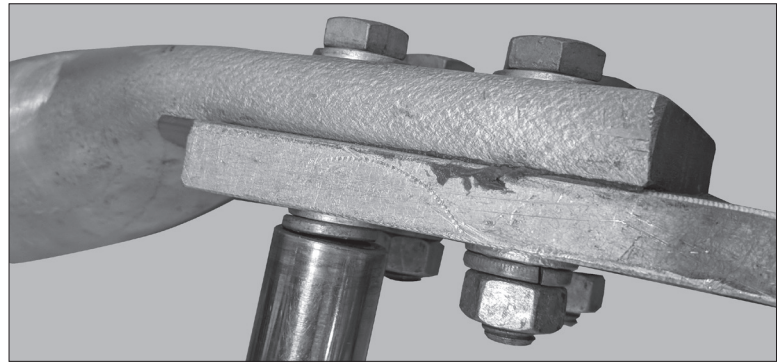

- 4 Completed Dead-End and Jumper Terminal assembly.









GLOBAL HEADQUARTERS
660 BETA DRIVE
CLEVELAND, OH 44143

+1 440 461 5200
INFO@PLP.COM
PLP.COM