

SpecSeal® Cast-in Device Drain

Cast-In Device for 2" (51 mm) Trade Size Floor Drain

1

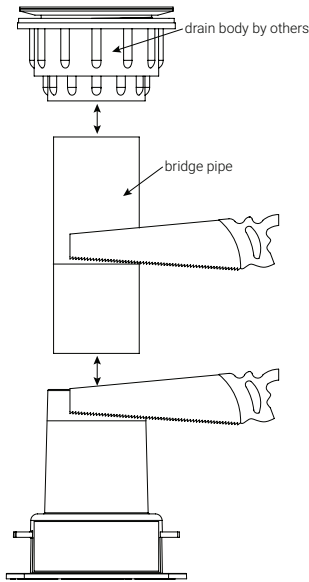

Drain device and bridge pipe to be cut to accommodate for concrete floor thickness. 2" drain body type and style may vary by manufacturer.

2

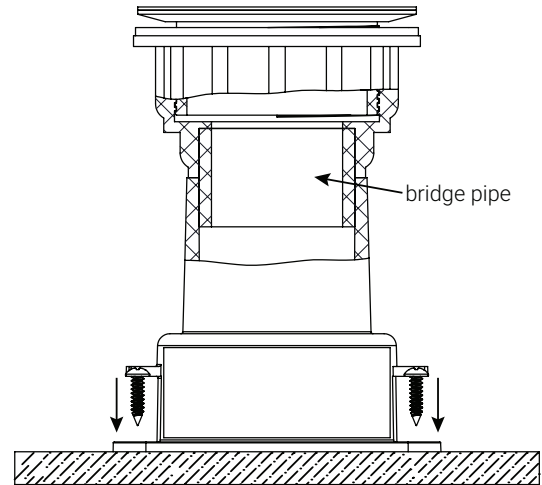

Weld drain body, drain device, and bridge pipe together using appropriate PVC cement. Fasten Drain Device body to plywood forms using steel screws.

3

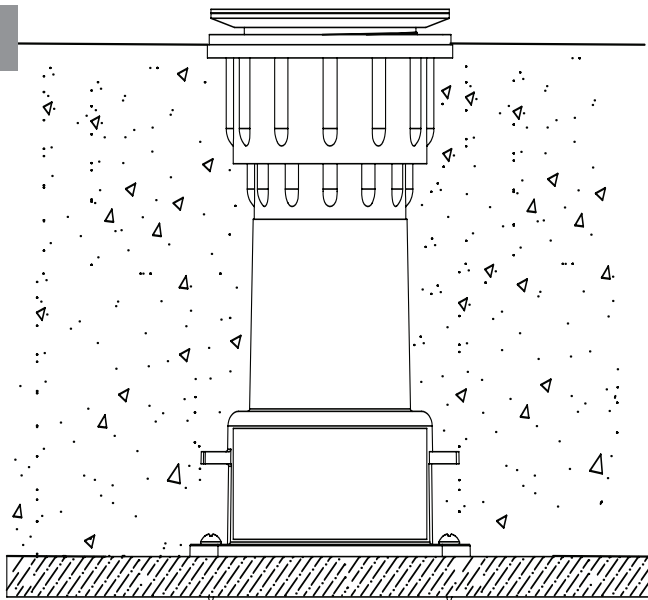

4

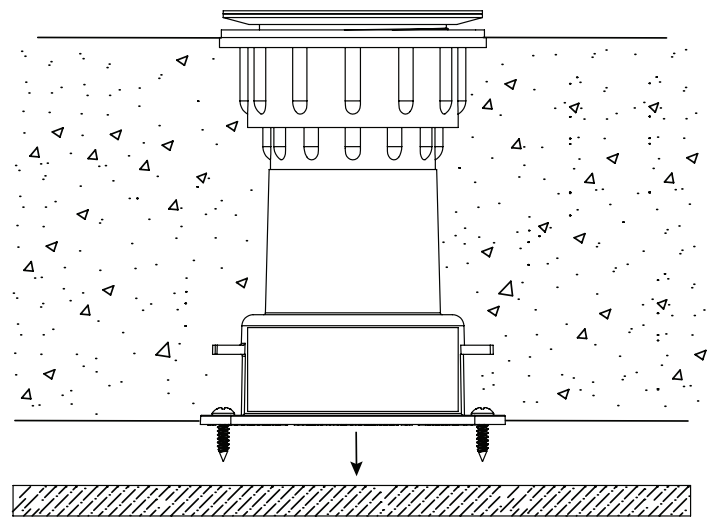

Remove temporary forms after concrete has cured.

Note: For more information on firestop installation, refer to ASTM E3157.