

SpecSeal® Quick Clip™ Perimeter Fire Barrier System (Field Installation)

1A

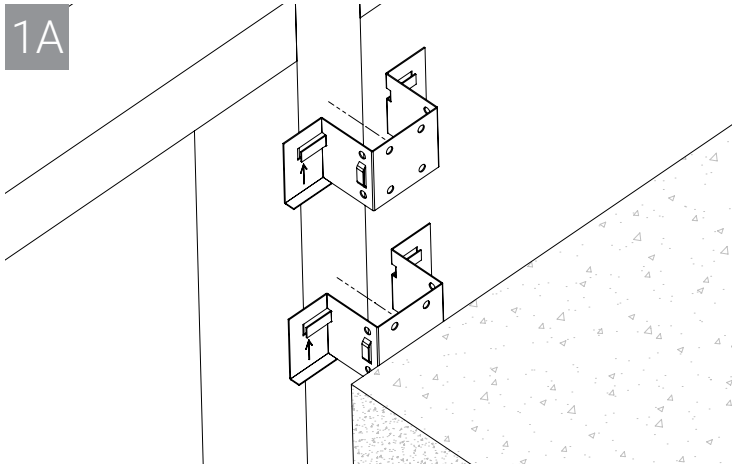

Clip U-Bracket onto mullions (vertical framing) nominally 2" (51 mm) from bottom of sill, flush with the bottom of the floor and 2" (51 mm) from the top of the transoms (horizontal framing) below the floor. U-Brackets lock into place with a strike of a mallet.

1B

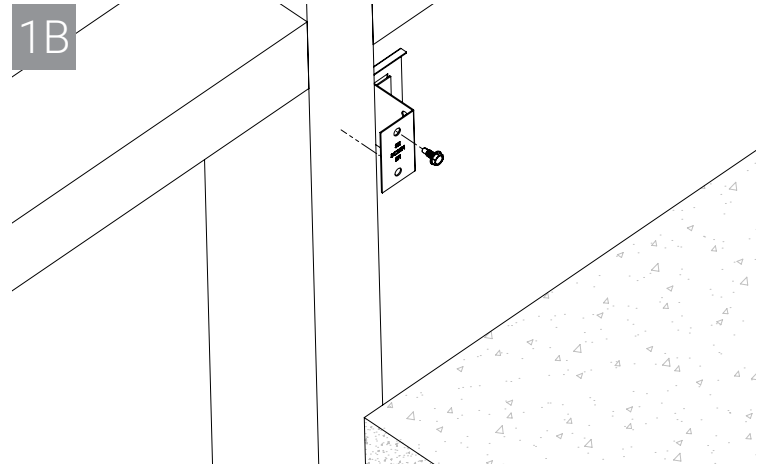

Attach Z-Bracket to mullion (vertical framing) using minimum of one No. 10 by min 1/2" long self-drilling, self-tapping steel screw or as specified in the applicable UL System. Z-Bracket to be located nominally 2" (51 mm) from bottom of sill and 2" (51 mm) from of the top of the transoms (horizontal framing) below the floor.

2 & 3

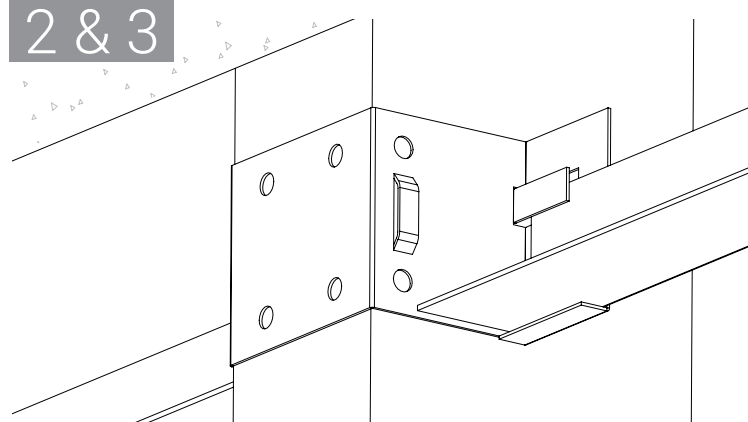

Measure distance between mullions and cut minimum 1-1/2" (38.1 mm) by 1-1/2" (38.1 mm) by min 16 gauge (1.5 mm) galvanized steel "L-shaped" angles to measured length minus 1/8" (3.2 mm) to max 5/8" (15.9 mm).

U-bracket: Insert "L-shaped" angle flush with bottom of the floor into Quick Clip™ U-Brackets slots so that bottom of angle rests on U-Bracket shelves.

Z-bracket: Insert Z-brackets onto each end of the "L-shaped" angle and install using minimum of one No. 10 by minimum 1/2" (13 mm) long self-drilling, self-tapping steel screw.

Z-bracket and angle assembly to be located flush with the bottom of the floor or as specified in the applicable UL System.

Note: For more information on firestop installation, refer to ASTM E3157.

Patent Pending



SpecSeal® Quick Clip™ Perimeter Fire Barrier System (Field Installation)

4

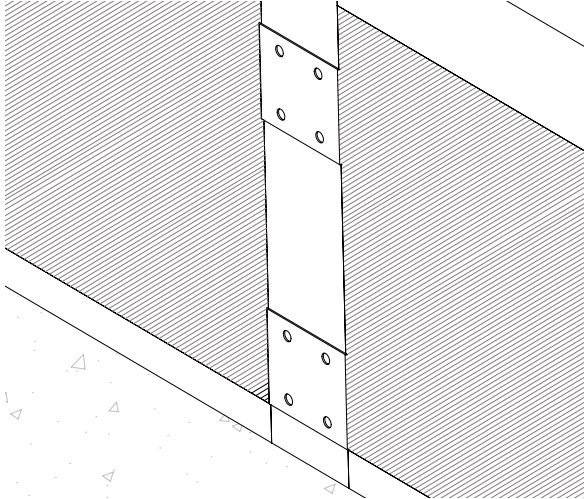

Curtain wall insulation batts to be installed as continuous pieces with one horizontal seam located at the "L-shaped" angle. Curtain wall insulation installed over the Quick Clip™ U- or Z-Brackets flush with the front face of the framing.

5

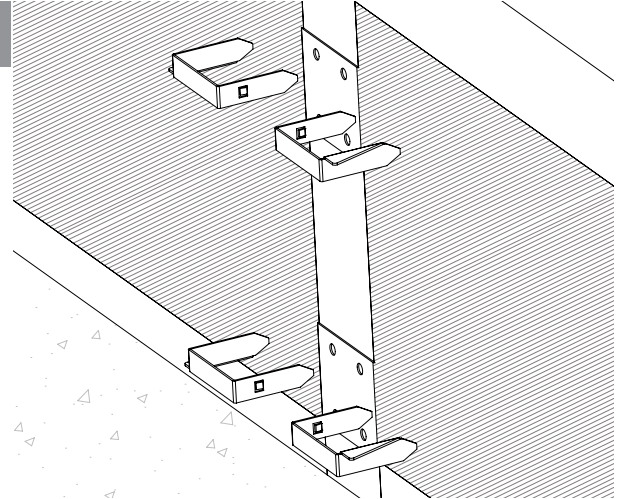

Insert Quick Clip™ Fasteners completely engaging clips at all U- or Z-Brackets on both sides of the framing.

Note: Additional steps are required in order to complete the installation. Follow applicable UL System for additional detail on the installation of the Safing System and for the sizing of the Mullion Covers.

6

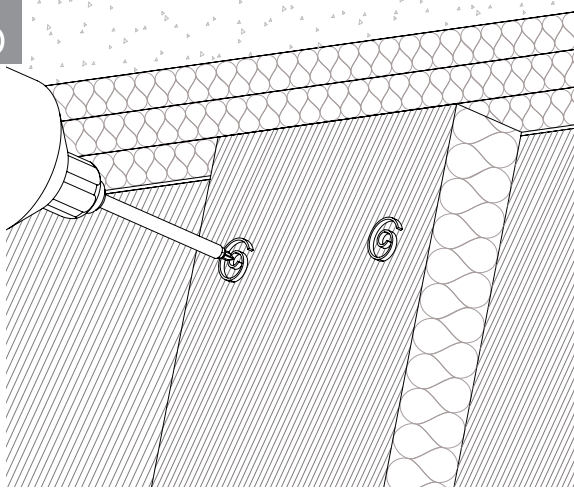

Mullion covers secured to the curtain wall insulation with min 3-3/4" (9.5cm) long galvanized steel spiral screws. Quick Clip™ Spiral Screws installed using a #2 Phillips head drill or equivalent. The number of screws and installation locations as are specified in the applicable UL Systems.

Note: For more information on firestop installation, refer to ASTM E3157.

Patent Pending

