

Optional Ground Attachment

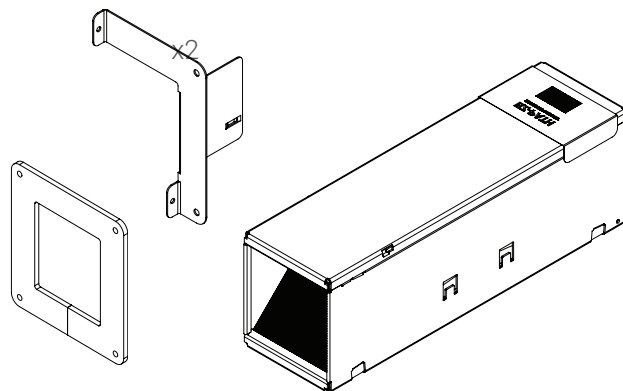

Parts Included (Not to Scale)
Devices not included in Part No. EZP144F

New Work Installation

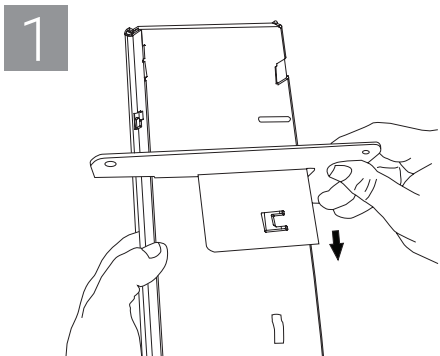

Slide the hook plate around pathway and engage hook tab firmly into pathway eye.

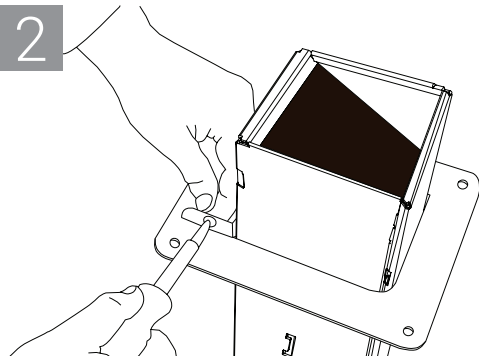

Join corners of plates together using 10-32 screws and nuts (included).

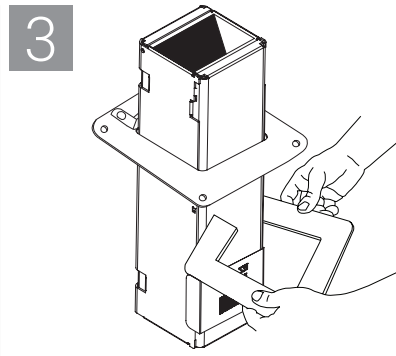

Install foam gasket and position below and against assembled plate flange.

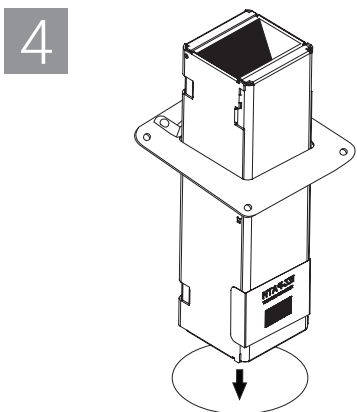

Place pathway into nominal 6 in. (153 mm) diameter opening.

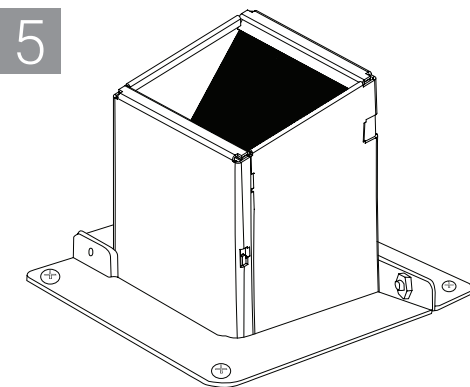

Fasten plate to concrete floor using 3/16" X 1-1/4" (5 mm x 32 mm) concrete screws or equivalent fastener installed through all four corners of plate.

Note: For more information on firestop installation, refer to ASTM E3157.

