

Four & Seven Gang Mounting Plates
(Part Numbers: EZIP433W, EZDP433GK, EZIP733W, EZDP733GK)

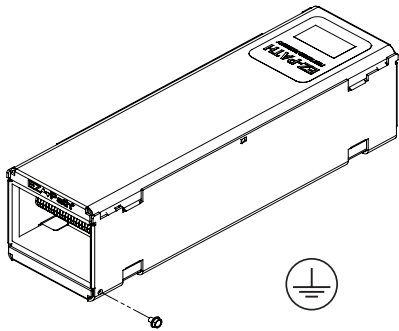

Optional Ground Attachment

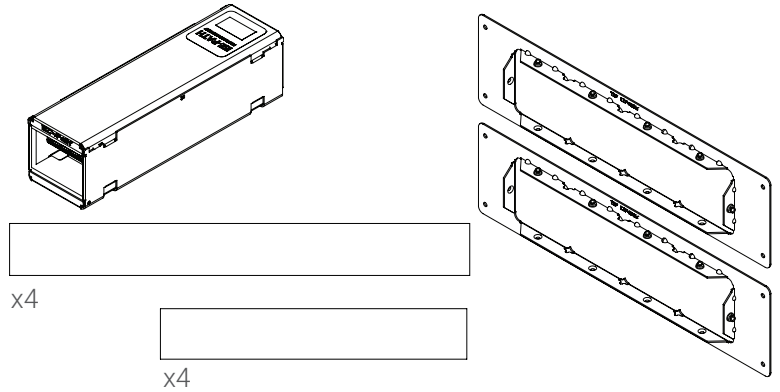

Parts Included (Not to Scale)
Devices not included in Cat. No. EZIP433W and EZIP733W

Option 1 – Installation in Finished Walls

1

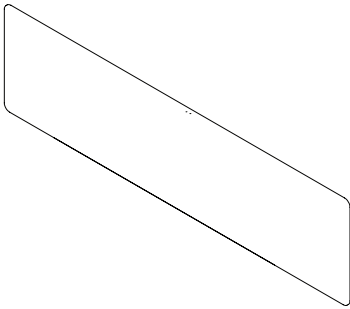

Cut opening in wall to accommodate for EZ-Path® Devices (See Table A)

2

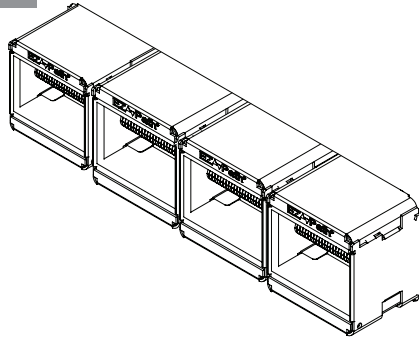

Install devices into opening with ends projecting equally from wall surfaces

3

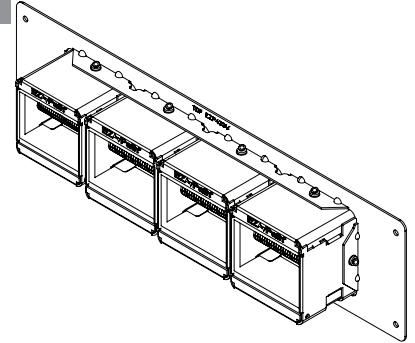

Apply gasket around opening on flat side of plate and install around devices on both sides of wall

4

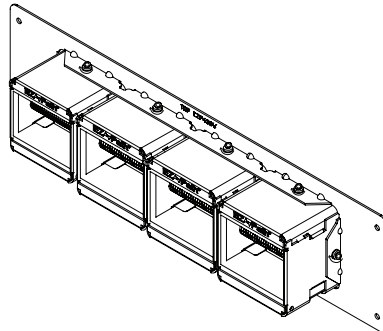

Tighten hex head screws and fasten the steel plate to both sides of wall as needed (See Table A)

Note: For more information on firestop installation, refer to ASTM E3157.



Four & Seven Gang Mounting Plates
(Part Numbers: EYP433W, EZDP433GK, EYP733W, EZDP733GK)

Option 2 – Installing Devices Prior to Wallboard (New Wall Construction)

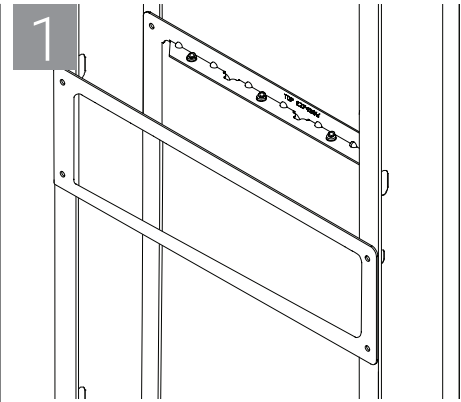

1
Fasten plates to studs with tabs projecting into wall ensuring that the plates are aligned.

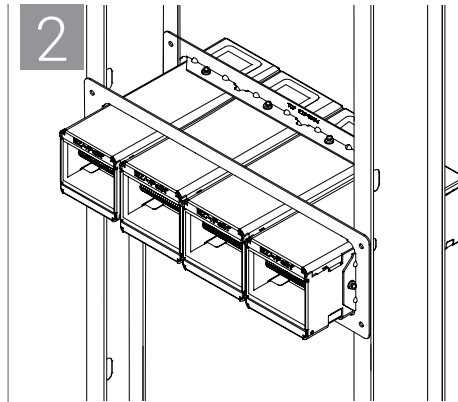

2
Insert devices into plates so that they project equally from both sides and tighten corresponding hex head screws to hold devices in place.

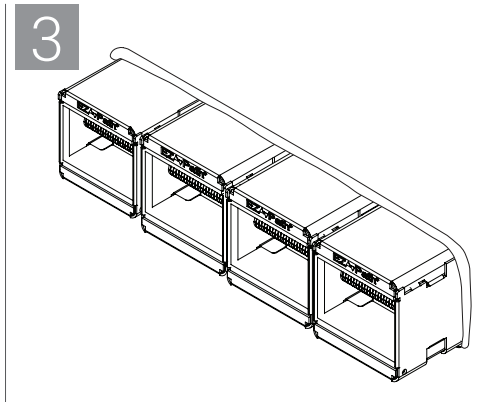

3
Gap between devices and finished gypsum board shall be filled with joint compound or SpecSeal® brand firestop sealant.

TABLE A: SLOT SIZE & CAPACITY

Stud spacing	16" (406 mm)	24" (610 mm)
Mounting plate part number	EYP433W	EYP733W
No. of Devices	(4) EYP33FWS	(7) EYP33FWS
Opening Size	12-1/8" x 3-1/8" (308 mm x 79 mm)	21-1/8" x 3-1/8" (537 mm x 79 mm)

FASTENER REQUIREMENTS

Fasten to studs	(OPTIONAL)	(REQUIRED)
-----------------	------------	------------

Consult applicable UL® system in the fire resistance directory for permissible types and sizes.

Note: For more information on firestop installation, refer to ASTM E3157.

