

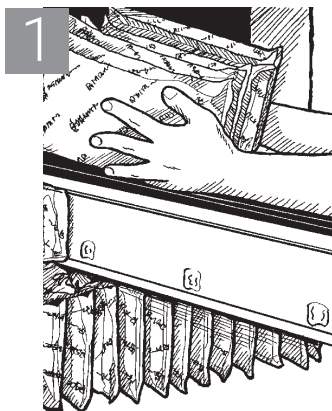

SpecSeal® Series SSB Firestop Pillows

GENERAL: Inspect areas to be protected. Remove any sharp edges or protruding wires or ties that could damage poly bags. **NOTE:** Do not cut or open outer poly bag.

Calculate pillow requirements in square inches in advance of installation as an indicator of the proper installed volume and compression. See Estimation Table for instructions concerning proper estimation techniques.



1 Compress Pillows and install with longest dimension through opening. Ends of Pillows to project equally from assembly surfaces. Pillows may be stacked and installed in groups as shown above.

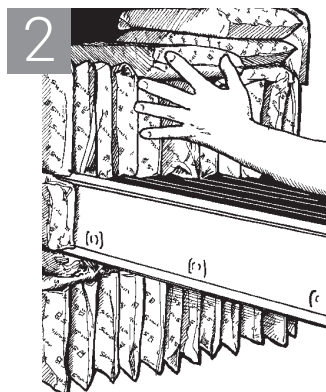

2 Pillows to completely fill annular space around penetrant.

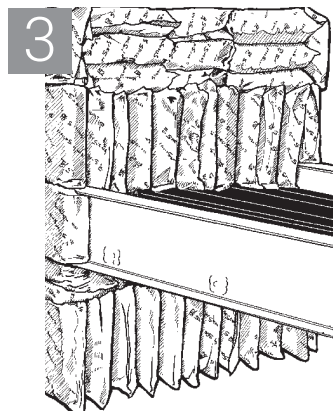

3 Smaller Pillows can be used to fill voids that will not accommodate larger pillows. SpecSeal® Firestop Putty is used to seal any small voids that will not accommodate Firestop Pillow.

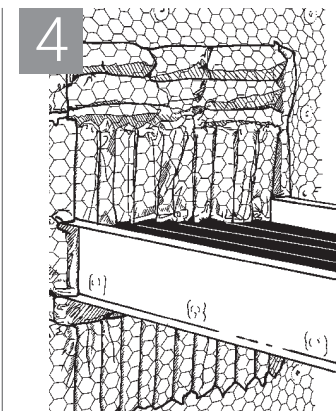

4 Check to make sure pillows are tightly compressed and all voids are closed. (If required by design, attach mesh using suitable fasteners to cover pillows and prevent unintentional or unauthorized removal)

Unless otherwise specified within the individual UL System, pillows are installed lengthwise through the opening to form a 9" (228 mm) seal.

When wire mesh is required: Generally, a 2"-3" (50-75 mm) overlap of the surrounding wall or floor surface is required. Install fasteners on 6" (152 mm) centers. A steel fender washer of sufficient diameter to completely overlap the opening through the mesh is required. The mesh may be fastened to concrete floors or concrete or CMU walls using suitable steel anchors (e.g. Tapcon® Fasteners by ITW Ramset). For hollow gypsum wallboard assemblies, attach mesh to the face of the wall using self-tapping, gypsum wallboard screws into the framing members surrounding the opening.

Note: For more information on firestop installation, refer to ASTM E3157.





SpecSeal® Series SSB Firestop Pillows

Using SpecSeal® Mortar to Reduce Opening Size

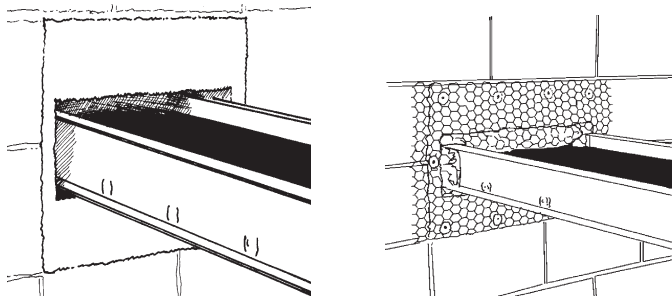

In the two photos shown above, SpecSeal Firestop Mortar has been installed around the cable tray as an economical void filler. In preparation, foam board forms are used to create the opening around the tray and to prevent leakage of the mortar from the wall cavity. After the mortar has dried, the forms are removed and the pillows are installed. Consult UL System No. C-AJ-4030 as well as the SpecSeal Firestop Mortar Product Data sheet for additional installation information.

Bottom-Up Installations

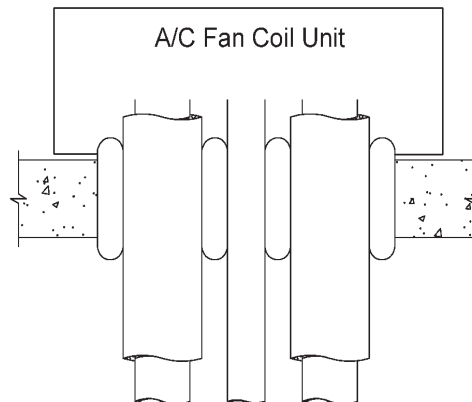

Pillows can be used to seal openings that are accessible only from the bottom as in this typical fan-coil installation. See UL System No. C-AJ-8052.

Product Estimator Information - Calculating Pillow Requirements

NOMINAL CROSS-SECTION AREA OF PILLOWS

Catalog Number	SSB14	SSB24	SSB26	SSB36
Nominal Dimensions (Uncompressed)	1" x 4" (2.54 cm x 10.2 cm)	2" x 4" (5.1 cm x 10.2 cm)	2" x 6" (5.1 cm x 15.24 cm)	3" x 6" (7.6 cm x 15.24 cm)
Nominal Area (Cross-sectional area uncompressed)	4 in. ² (25.8 cm ²)	8 in. ² (51.6 cm ²)	12 in. ² (77.4 cm ²)	18 in. ² (116 cm ²)
Effective Yield (Cross-sectional area compressed)	2.9 in. ² (18.7 cm ²)	5.7 in. ² (36.8 cm ²)	8.6 in. ² (55.5 cm ²)	12.9 in. ² (83.2 cm ²)

Measure the size of the opening to be sealed and calculate the total area of the opening in square inches. Measure and calculate the approximate area occupied by the penetrants. Calculate the net area to be sealed by subtracting the area occupied by the penetrants from the total area of the opening. To allow for the required compression of the pillows, multiply the net area by 1.4. This will provide a compression factor of 29%.

In the example shown above, the opening is 12" x 24" with an 18" wide tray. The cable depth in the tray is about 3". The area of the opening is 12 x 24 = 288 sq. in. The approximate area of the cables is 3 x 18 = 54 sq. in. Subtracting the area of the cables from the total area of the opening yields a net area of 234 sq. in. 234 x 1.4 = approx. 328 sq. in. to be filled by pillows. Using the table above to determine the nominal area of the various pillows, we can determine that approximately 28 (328 ÷ 12) SSB26 pillows would be required. The number of pillows required will of course vary by the size of the pillow being utilized. Generally, a small percentage of smaller pillows will be required along with the larger ones. A test opening of this size utilized 24 SSB26 pillows, along with 4 SSB24's and 4 SSB14's

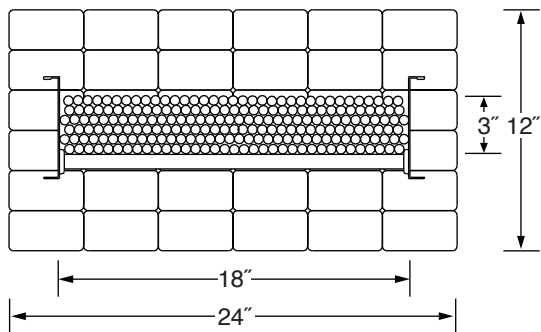

Note: For more information on firestop installation, refer to ASTM E3157.

