

SpecSeal®

QC

PERIMETER FIRE CONTAINMENT PROTECTION

Quick Clip™ Perimeter Fire Containment System

SpecSeal® Quick Clip™ Perimeter Fire Containment System is designed to accelerate the installation of curtain wall insulation for perimeter fire containment systems. The system's unique U-brackets clip onto the mullions without direct attachment by screws to support the curtain wall insulation. Self-locking fasteners secure the insulation panels in place. Each U-bracket has a receiving slot to lock an "L-shaped" stiffener channel in place without the need for mechanical attachment by screws.

Features & Benefits

- Tested to ASTM E1233 for 100 MPH+ wind-loads
- Reduce or eliminate use of steel screws into framing members
- Tested for up to 2 Hours of fire resistance when tested to ASTM E2307

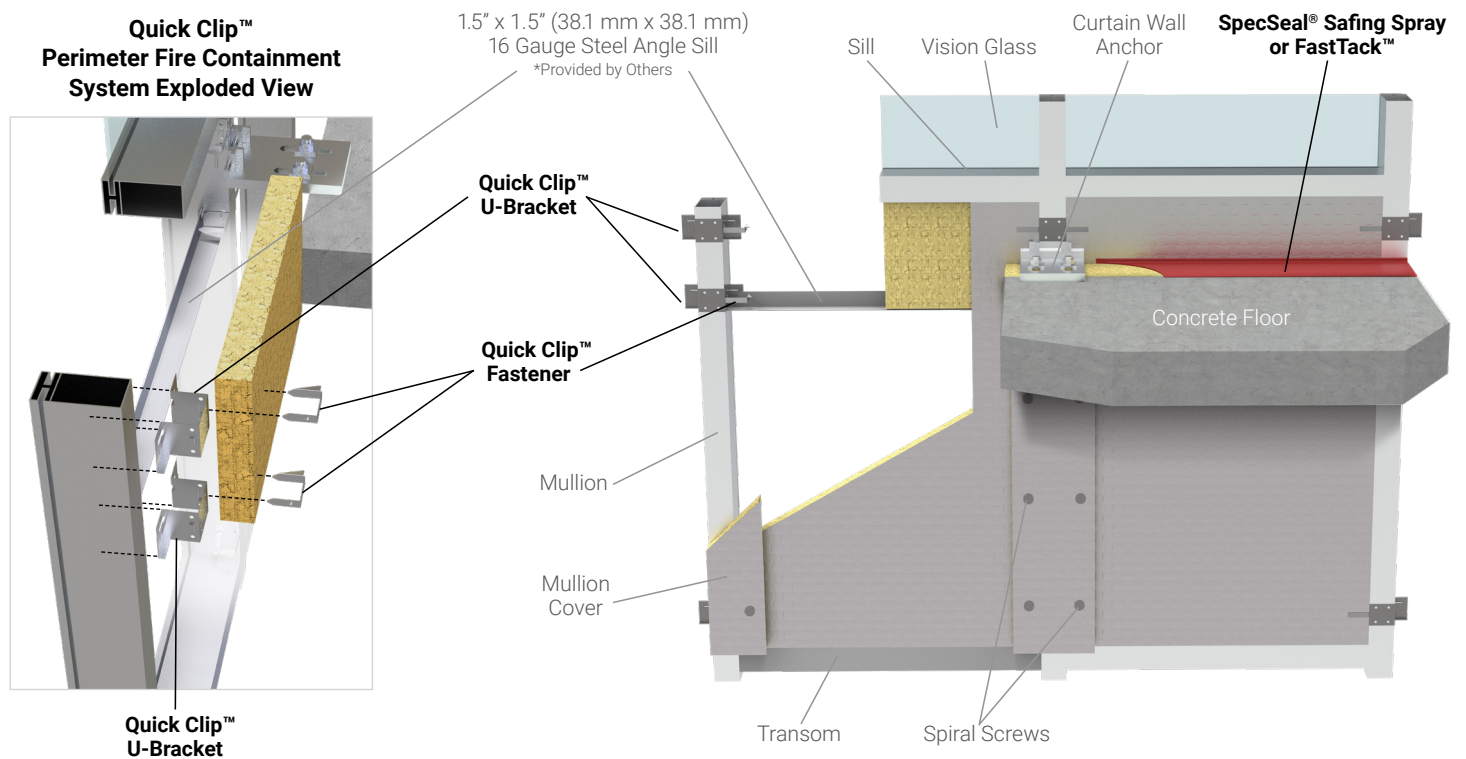
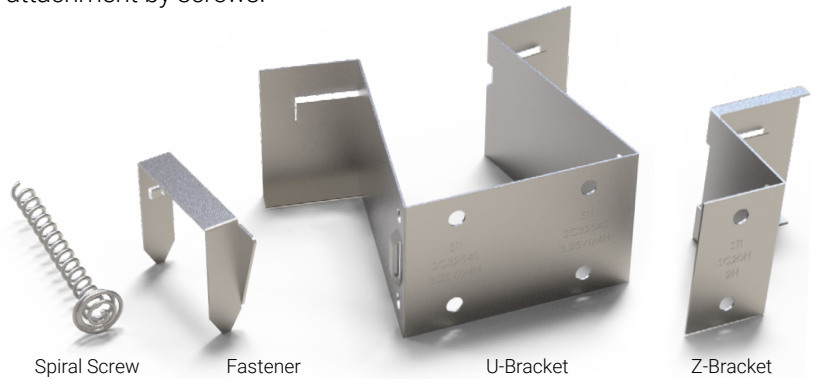

Patent Numbers: 10329761, 10329762, 10626603, 10724233







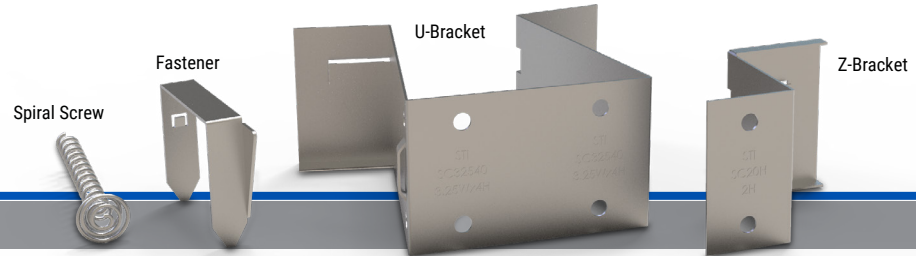

SpecSeal™
QC

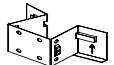
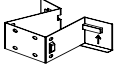
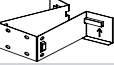
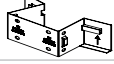
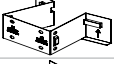
PERIMETER FIRE CONTAINMENT PROTECTION

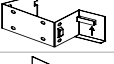
Quick Clip™ Perimeter Fire Containment System

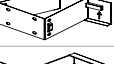

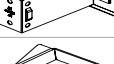
ORDERING INFORMATION

| Catalog Number | UPC Number | Description | Product Image | Mullion Width | | Insulation | Weight (Each) | Case Qty. | Material |
|----------------|--------------|--------------------------|---|------------------|------------------|---------------|--------------------|-----------|-------------------------------|
| | | | | Min. | Max. | | | | |
| SC25020 | 730573100011 | Quick Clip™ U-Bracket* |  | | | 2" (50.8 mm) | 0.31 lbs (0.14 kg) | 100 | Heat treated galvanized steel |
| SC25030 | 730573100028 | Quick Clip™ U-Bracket* |  | 2.375" (60.3 mm) | 2.525" (65.1 mm) | 3" (76.2 mm) | 0.30 lbs (0.14 kg) | 100 | |
| SC25040 | 730573100035 | Quick Clip™ U-Bracket* |  | | | 4" (101.6 mm) | 0.35 lbs (0.16 kg) | 100 | |
| SC30020 | 730573100042 | Quick Clip™ U-Bracket |  | | | 2" (50.8 mm) | 0.28 lbs (0.13 kg) | 100 | Heat treated galvanized steel |
| SC30030 | 730573100059 | Quick Clip™ U-Bracket |  | 2.875" (73 mm) | 3.2" (81.2 mm) | 3" (76.2 mm) | 0.32 lbs (0.15 kg) | 100 | |
| SC30040 | 730573100066 | Quick Clip™ U-Bracket |  | | | 4" (101.6 mm) | 0.37 lbs (0.17 kg) | 100 | |
| SC32520 | 730573100073 | Quick Clip™ U-Bracket |  | | | 2" (50.8 mm) | 0.28 lbs (0.13 kg) | 100 | Heat treated galvanized steel |
| SC32530 | 730573100080 | Quick Clip™ U-Bracket |  | 3.125" (79.4 mm) | 3.45" (87.6 mm) | 3" (76.2 mm) | 0.34 lbs (0.15 kg) | 100 | |
| SC32540 | 730573100097 | Quick Clip™ U-Bracket |  | | | 4" (101.6 mm) | 0.38 lbs (0.17 kg) | 100 | |
| SC20H | 730573100103 | Quick Clip™ Z-Bracket |  | | | 2" (50.8 mm) | 0.13 lbs (0.06 kg) | 100 | Galvanized steel |
| SC30H | 730573100110 | Quick Clip™ Z-Bracket |  | All | All | 3" (76.2 mm) | 0.15 lbs (0.07 kg) | 100 | |
| SC40H | 730573100127 | Quick Clip™ Z-Bracket |  | | | 4" (101.6 mm) | 0.14 lbs (0.06 kg) | 100 | |
| SB2020 | 730573100257 | Quick Clip™ Fastener |  | All | All | All | 0.04 lbs (0.02 kg) | 100 | Galvanized steel |
| SA375 | 730573100264 | Quick Clip™ Spiral Screw |  | All | All | All | 0.02 lbs (0.01 kg) | 1000 | Galvanized steel |

TEST STANDARDS: ASTM E1233, ASTM E2307



ORDERING INFORMATION - PERIMETER FIRE CONTAINMENT FIRESTOP SPRAY

| Catalog Number | UPC Number | Description | (UOM) Qty. | Case Qty. | Weight (Each) |
|----------------|--------------|--|------------|-----------|----------------------|
| SFS105 | 730573071175 | 5 gallon pail - 1,155 cu. in. (19 liters) SpecSeal® Safing Spray for Perimeter Fire Containment | 1 | 1 | 56.00 lbs (25.40 kg) |
| FT305 | 730573011904 | SpecSeal® Fast Tack® Firestop Spray 5 gallon pail - 1,155 cu. in. (19 liters) | 1 | 1 | 51.33 lbs (23.28 kg) |
| FT305R | 730573011935 | SpecSeal® Fast Tack® Firestop Spray 5 gallon pail - 1,155 cu. in. (19 liters) | 1 | 1 | 51.33 lbs (23.28 kg) |

* For single extrusion mullions only



1-800-992-1180
stifirestop.com



[Click here to learn more about](#)



ZSTI3499-34021