



# Quick Clip™ L-Bracket Perimeter Fire Containment System

**SpecSeal® Quick Clip™ L-Bracket Perimeter Fire Containment System** is the fastest way to install curtain wall insulation for perimeter fire containment systems. Simply fasten the L-shaped brackets to the mullion, cut and fit the curtain wall insulation, and then secure the insulation in place with self-locking fasteners. The brackets also allow the stiffener channel to be locked into place without additional mechanical attachment. This versatile system is great for factory-insulated curtain wall panels or recladding projects where the system will be installed from the building's exterior.

## Features & Benefits

- Tested to ASTM E1233 for 100 MPH+ wind-loads
- All components can be installed from the glass side to make glazing easier— no more flipping units
- Meets ASTM E2307 for up to 2 hours of fire resistance
- Patent Numbers: 10329761, 10329762, 10626603, 10724233, 11898348

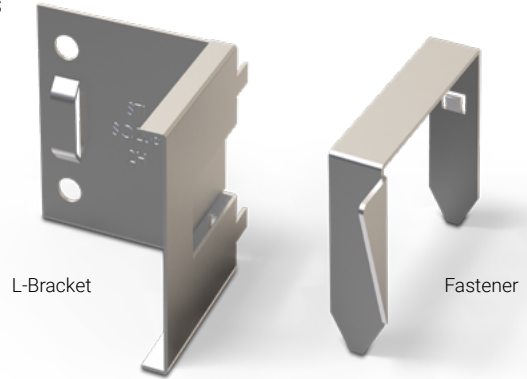

**Quick Clip™  
Perimeter Fire Containment  
System Exploded View**  
(shown from exterior)

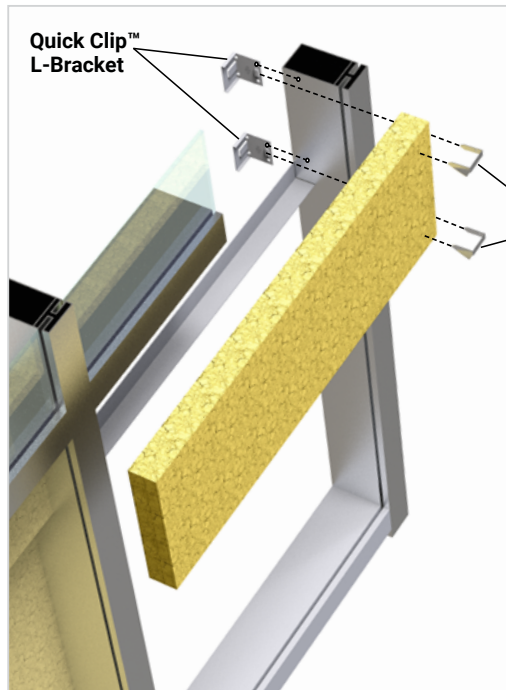



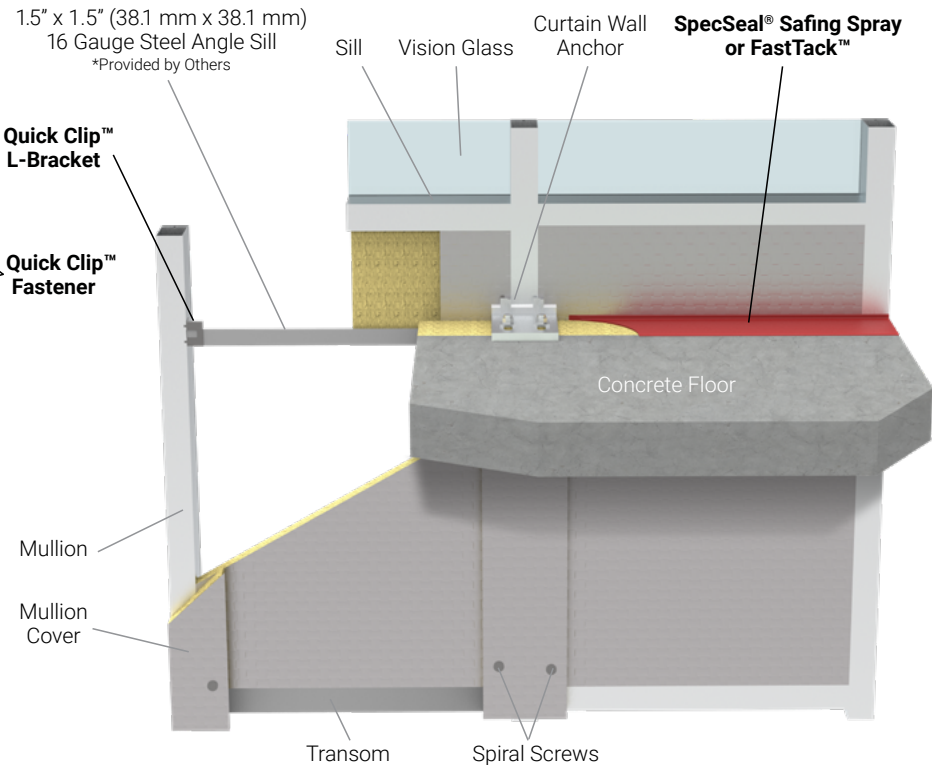

**Completed field installation**  
(some components installed by others)

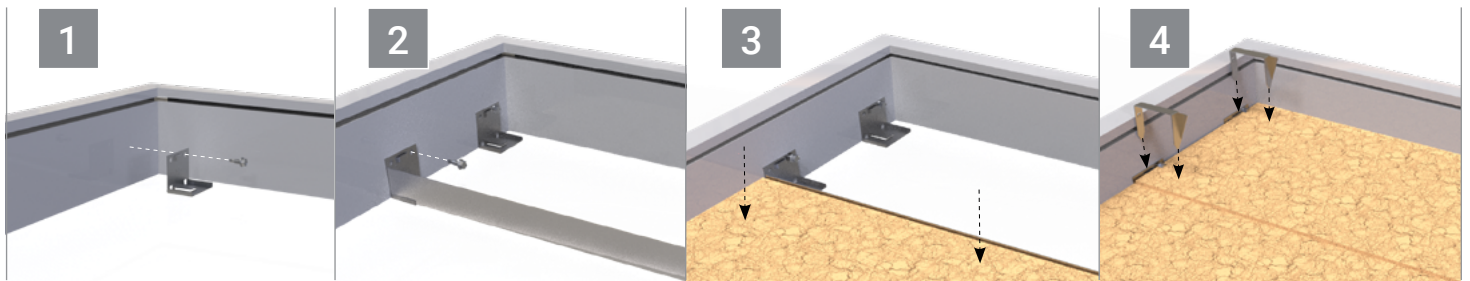

The easiest factory installed system available today.

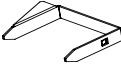

## ORDERING INFORMATION

Catalog Number	UPC Number	Catalog Number	Product Name	Product Image	Mullion Width	Insulation Thickness	Weight (Each)	Case Qty	Material
SC20B	730573100271	SC20B	Quick Clip™ L-Bracket			2" (50.8 mm)	0.09 lbs (0.04 kg)	100	
SC30B	730573100288	SC30B	Quick Clip™ L-Bracket		All	3" (76.2 mm)	0.11 lbs (0.05 kg)	100	Galvanized steel
SC40B	730573100295	SC40B	Quick Clip™ L-Bracket			4" (101.6 mm)	0.13 lbs (0.06 kg)	100	
SB2020	730573100257	SB2020	Quick Clip™ Fastener		All	All	0.04 lbs (0.02 kg)	100	Galvanized steel
SA375	730573100264	SA375	Quick Clip™ Spiral Screws		N/A	All	0.02 lbs (0.01 kg)	1000	Galvanized steel

TEST STANDARDS: ASTM E1233, ASTM E2307



## ORDERING INFORMATION - PERIMETER FIRE CONTAINMENT FIRESTOP SPRAY

Catalog Number	UPC Number	Description	(UOM) Qty.	Case Qty.	Weight (Each)
SFS105	730573071175	5 gallon pail - 1,155 cu. in. (19 liters) SpecSeal® Safing Spray for Perimeter Fire Containment	1	1	56.00 lbs (25.40 kg)
FT305	730573011904	SpecSeal® Fast Tack® Firestop Spray 5 gallon pail - 1,155 cu. in. (19 liters)	1	1	51.33 lbs (23.28 kg)
FT305R	730573011935	SpecSeal® Fast Tack® Firestop Spray 5 gallon pail - 1,155 cu. in. (19 liters)	1	1	51.33 lbs (23.28 kg)



Firestop, Smoke, & Sound Solutions  
1 (800) 992-1180 [stifirestop.com](http://stifirestop.com)



Click here to  
learn more about

