

EZ-Path® Cable Tray Retrofit Device
(Part Numbers: EZCTR612, EZCTR614, EZCTR616, & EZCTR618)

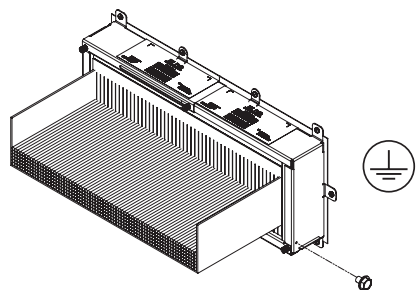

Optional Ground Attachment

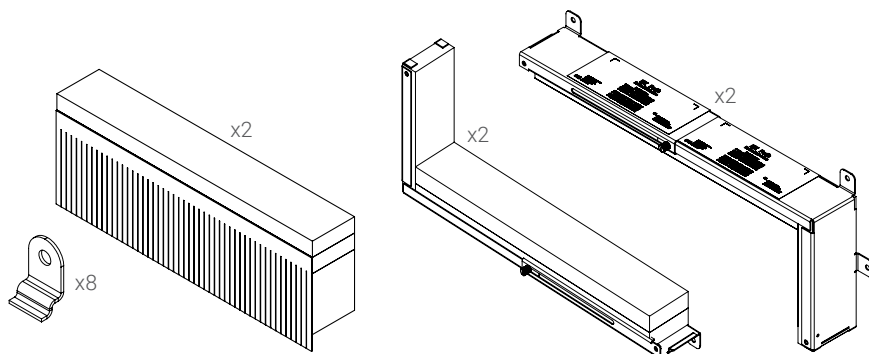

Parts Included (Not to Scale)

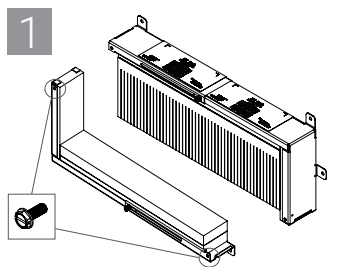

Remove corner screws and separate device into two halves.

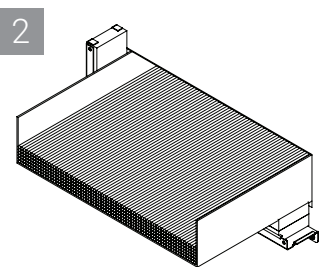

Tightly abut bottom half of tray device against underside of cable tray and face of wall. Fasten mounting tabs of device to wall using appropriate fasteners (see table A).

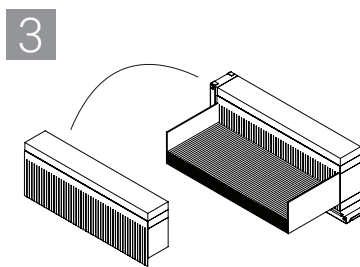

Place foam block with skirt into tray.

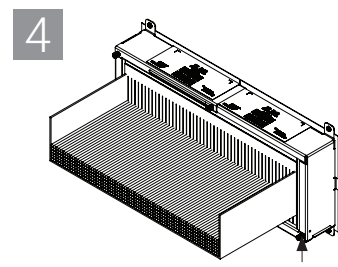

Attach top half of device to bottom half by inserting the interlocking tabs into slots. Secure device halves together using screws from Step 1. Fasten mounting tabs of device to wall using appropriate fasteners (see table A).

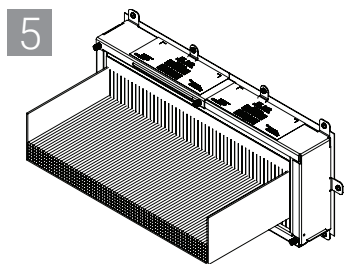

Insert provided mounting tabs into slots on top and bottom of device through clear name plates. Fasten mounting tabs of device to wall using appropriate fasteners (see table A).

TABLE A: FASTENER TYPES

Type of Wall	Fastener Type
Gypsum Board	No. 8 min 1-1/2 in. (38 mm) long steel screws featuring hi-lo threads and pan-heads
Concrete	3/16" (4.8 mm) diameter steel concrete screws

Note: For more information on firestop installation, refer to ASTM E3157.