

MDM150 Fire-Rated Cable Transit

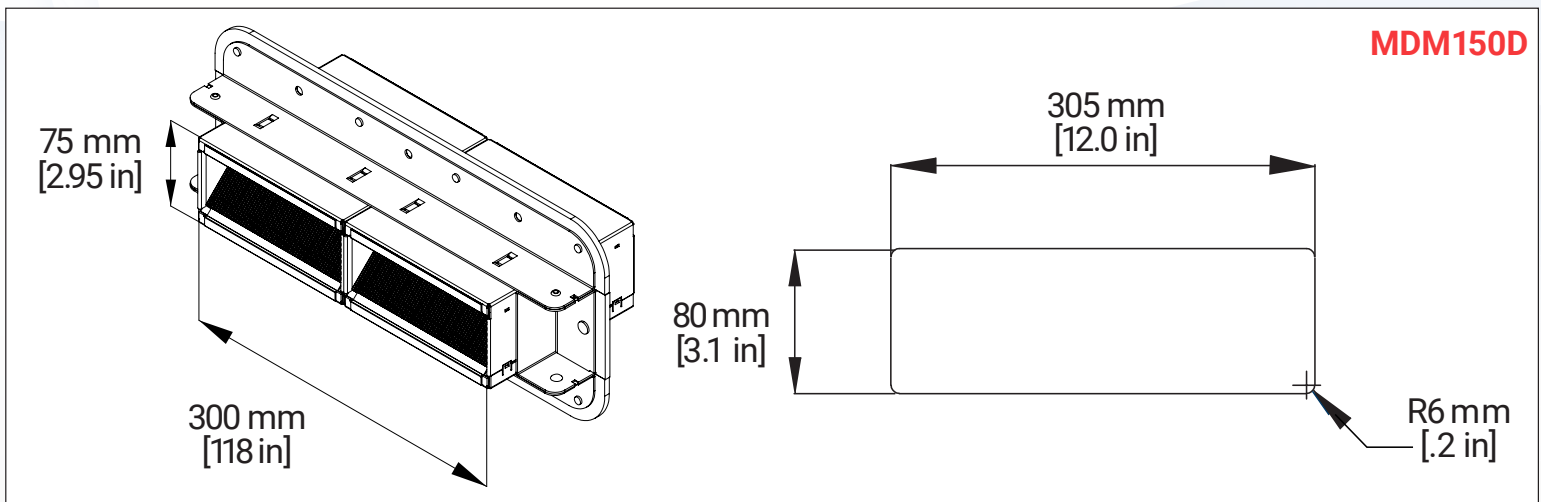

Note: Please refer to Type Approval Certificates for insulation requirements and maximum opening dimensions.

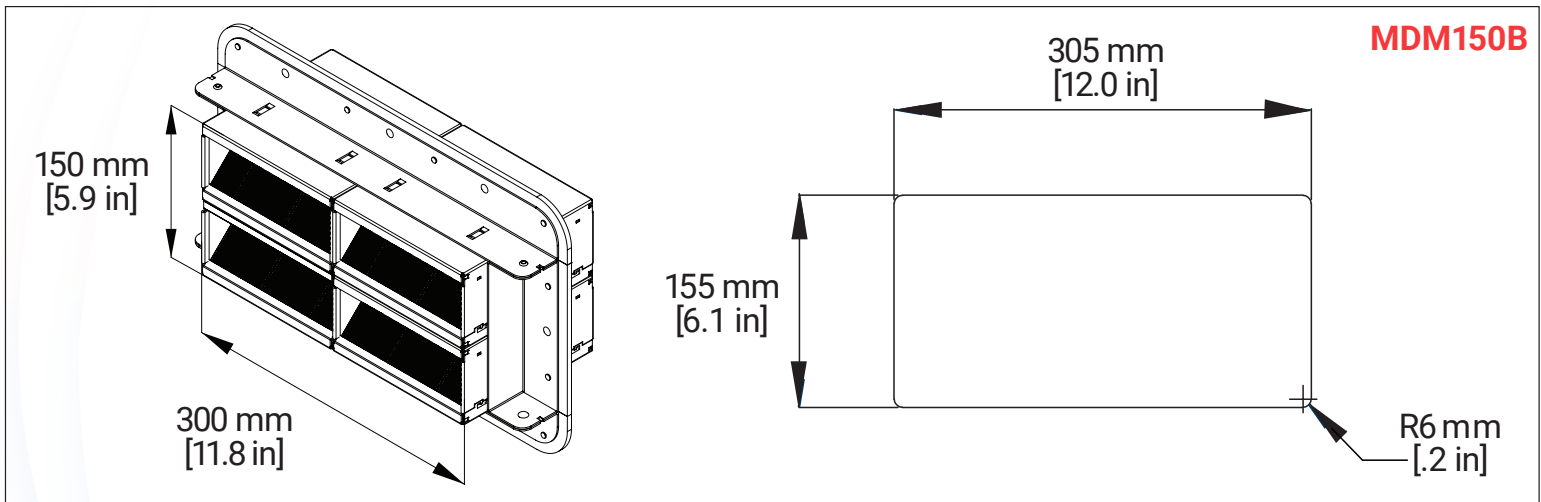
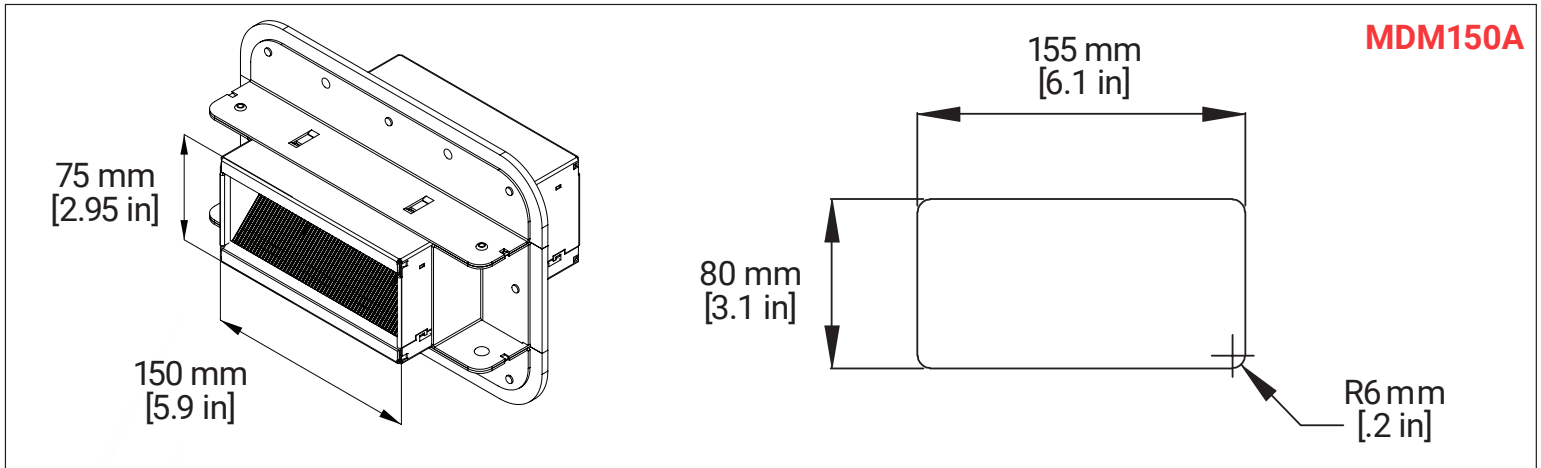

MDM150 Fire-Rated Cable Transit

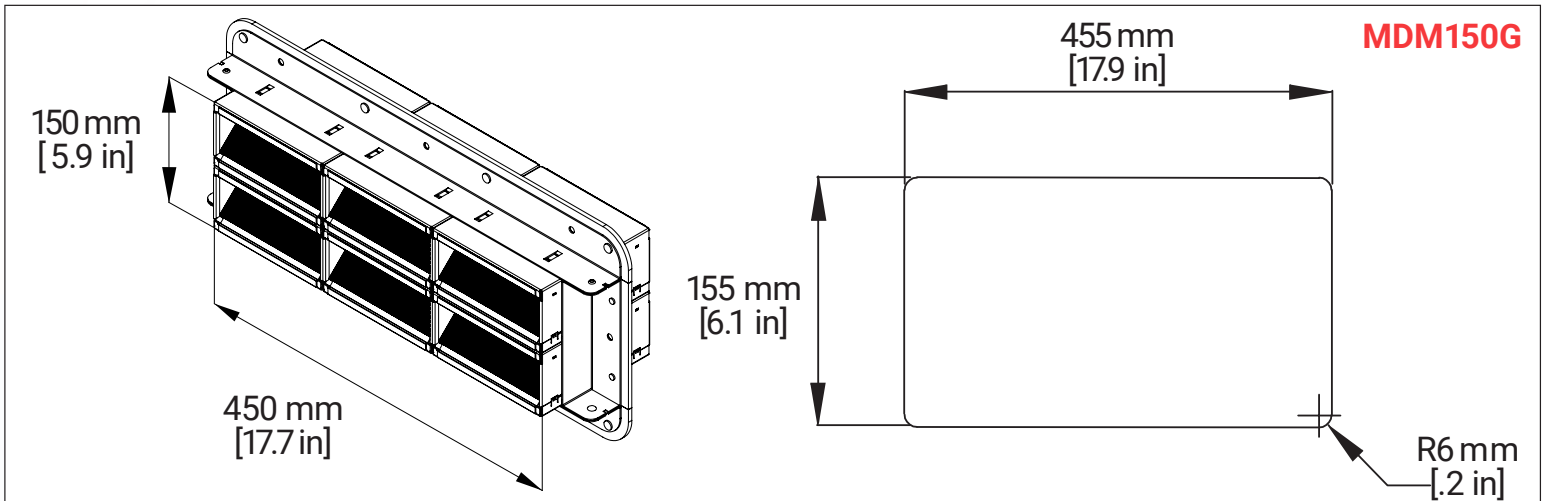
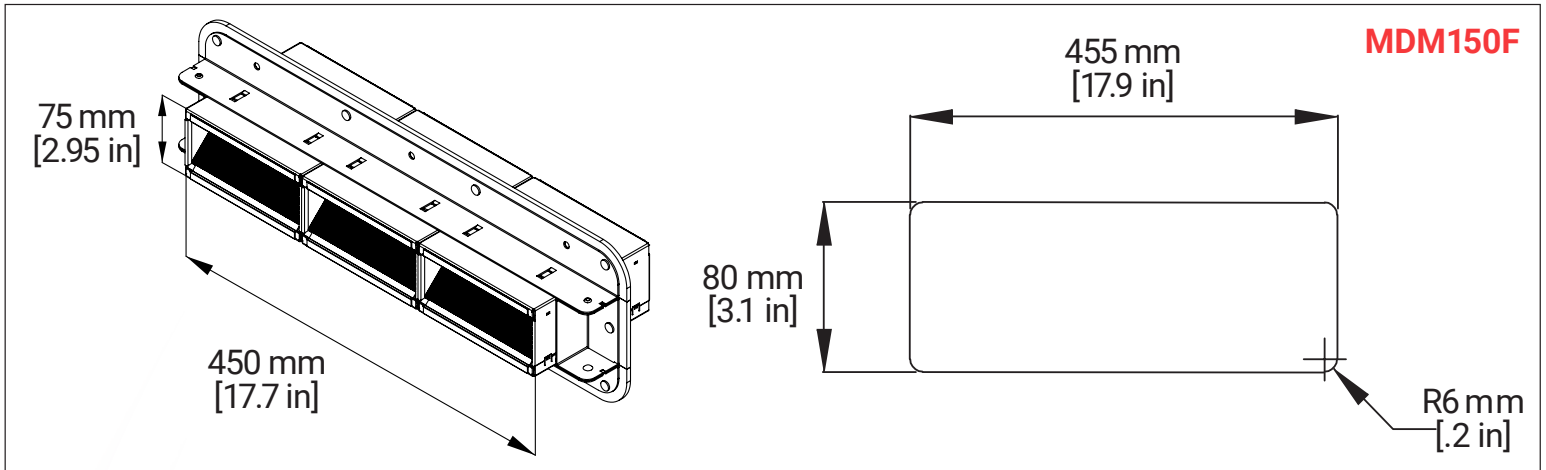

Note: Please refer to Type Approval Certificates for insulation requirements and maximum opening dimensions.



MDM150 Fire-Rated Cable Transit

Deck or Bulkhead Installation

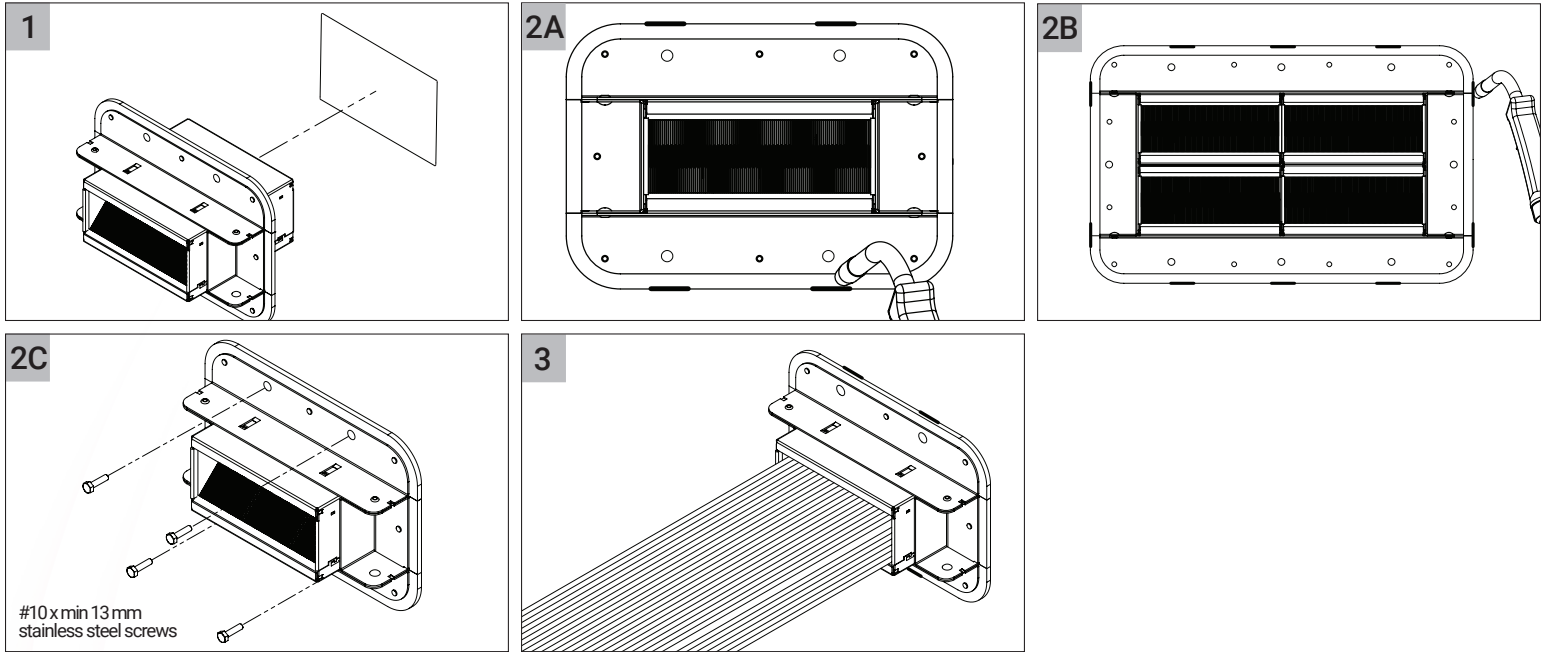

Transit Dimensions

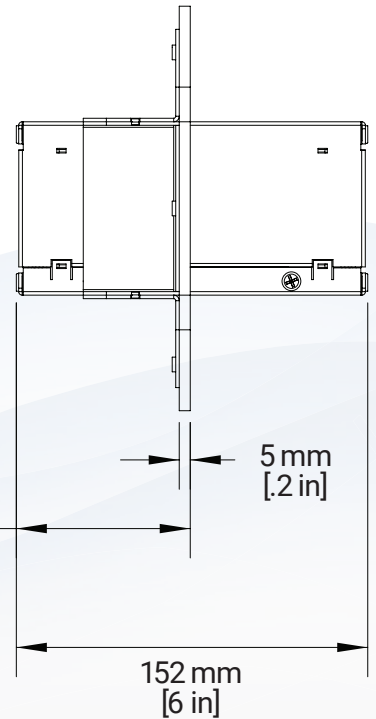
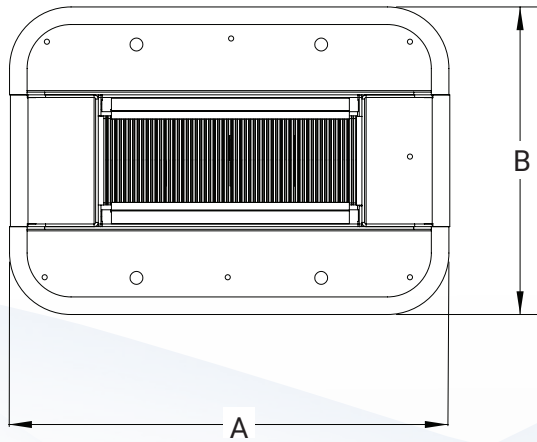

TRANSIT DIMENSIONS

Catalog Number	(A)		(B)	
	mm	in	mm	in
MDM150A	250	9.8	175	6.9
MDM150B	400	15.7	250	9.8
MDM150D	400	15.7	175	6.9
MDM150F	551	21.7	175	6.9
MDM150G	551	21.7	250	9.8

Note: Please refer to Type Approval Certificates for insulation requirements and maximum opening dimensions.

