

Chlorine, Free, Ultra Low Range

DOC316.53.01546

Fluorescence Method

Method 10314

2 to 100 µg/L Cl₂

Reagent

Scope and application: For testing free chlorine in clean water applications. Accurate to less than 20 ppb to prevent reverse osmosis (RO) membrane damage. This product has not been evaluated to test for chlorine and chloramines in medical applications in the United States.



Test preparation

Before starting

Analyze the samples immediately. The samples cannot be preserved for later analysis.

Do a reagent blank calibration before a set of new reagent bottles is used. Refer to [Reagent blank calibration](#) on page 4.

Always do tests in 16-mm sample vials. Do not put the instrument in the sample or pour the sample into the sample port.

If the sample temperature is higher or lower than 20 ± 3 °C (68 ± 5.5 °F), refer to [Temperature correction](#) on page 3 to calculate the actual reading.

Pretreat glass sample containers, sample vials and caps to remove chlorine demand. Refer to [Sample collection](#) on page 2.

Rinse the sample vial and cap with the sample three times before the vial is filled.

Make sure that the vials are clean and there are no scratches where the light passes through them.

Make sure that there are no fingerprints or liquid on the external surface of the vials. Wipe with a no-lint cloth before measurement.

Cold waters can cause condensation on the vial or bubbles in the vial. Examine the vial for condensation or bubbles. Remove condensation with a no-lint cloth. Invert the vial to remove bubbles.

Keep the cap on the vials when not in use to prevent ammonia contamination.

Install the vial cover on the vial before READ is pushed.

Do not use the same vials for free and total chlorine. If trace iodide from the total chlorine reagent is carried over into the free chlorine determination, monochloramine will interfere. It is best to use separate, dedicated vials for free and total chlorine measurements.

If the test result is over-range, dilute the sample with a known volume of high quality, chlorine demand-free water and do the test again. Some loss of chlorine may occur due to the dilution. Multiply the result by the dilution factor.

After the test, immediately empty and rinse the sample cell. Rinse the sample cell and cap three times with deionized water.

Review the Safety Data Sheets (MSDS/SDS) for the chemicals that are used. Use the recommended personal protective equipment.

Dispose of reacted solutions according to local, state and federal regulations. Refer to the Safety Data Sheets for disposal information for unused reagents. Refer to the environmental, health and safety staff for your facility and/or local regulatory agencies for further disposal information.

Items to collect

Description	Quantity
Fluorescence Free Chlorine Reagent 1	5 drops
Fluorescence Free Chlorine Reagent 2	5 drops
Glass vial with cap, 16 mm	1
Glass beaker, 100 mL (optional)	1
Sample vial holder	1

Sample collection

- Analyze the samples immediately. The samples cannot be preserved for later analysis.
- Chlorine is a strong oxidizing agent and is unstable in natural waters. Chlorine reacts quickly with various inorganic compounds and more slowly with organic compounds. Many factors, including reactant concentrations, sunlight, pH, temperature and salinity influence the decomposition of chlorine in water.
- Collect samples in clean glass bottles. Do not use plastic containers because these can have a large chlorine demand.
- Pretreat glass sample containers, sample vials, caps and other items that the sample may touch to remove chlorine demand. Soak the glass sample containers, sample vials, caps and other items that the sample may touch in a weak bleach solution (1 mL commercial bleach to 1 liter of deionized water) for at least 1 hour. Rinse fully with deionized or distilled water. If sample containers, sample vials and caps are rinsed fully with deionized or distilled water after use, only occasional pretreatment is necessary.
- Make sure to get a representative sample. If the sample is taken from a spigot or faucet, let the water flow for at least 5 minutes. Let the container overflow with the sample several times and then put the cap on the sample container so that there is no headspace (air) above the sample.
- If the sample is collected in a sample vial from a spigot or faucet, adjust the water flow to add the sample carefully. As an alternative, collect the sample in a chlorine pretreated beaker. Rinse the beaker 3 times with the sample before the sample is collected.

Test procedure

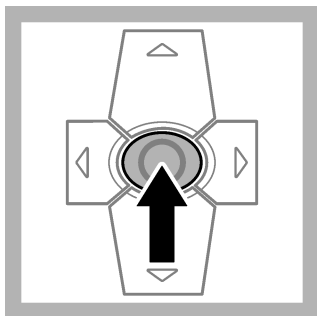

1. Set the instrument to on.

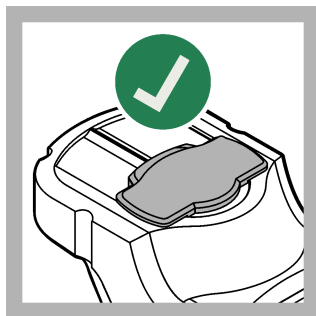

2. Keep the sample port cover closed during startup.

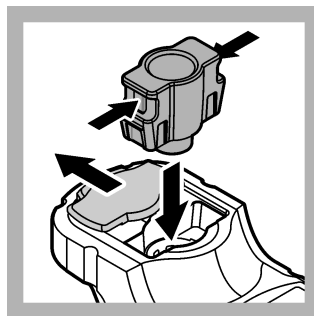

3. After startup, install the vial adapter. Push in the tabs on the sides of the vial adapter as shown.



4. Select **TESTS**.



5. Select **FREE CHLORINE**.

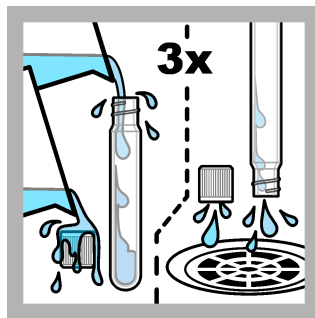

6. Rinse the sample vial and cap three times with the sample.

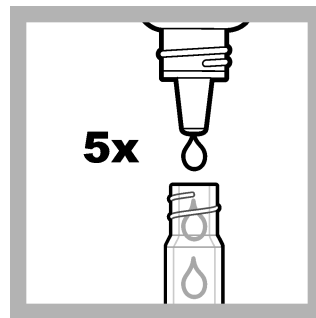

7. Add 5 drops of Fluorescence Free Chlorine **Reagent 1**. Hold the bottle vertically.

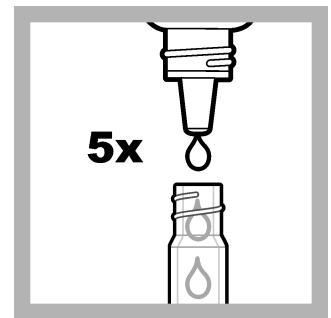

8. Add 5 drops of Fluorescence Free Chlorine **Reagent 2**. Hold the bottle vertically.

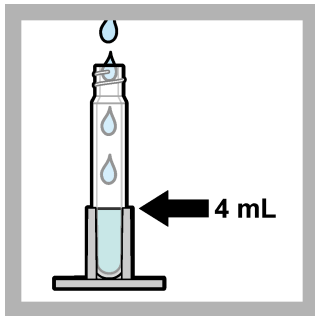

9. Put the sample vial in the sample vial holder. Add the sample to the top of the sample vial holder (4 mL).

If more than 4 mL of sample is added, there is a very small effect on the result.

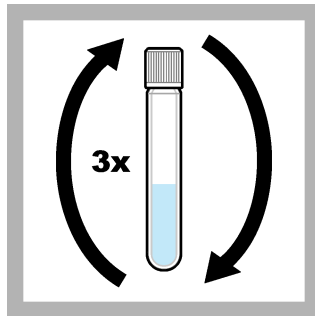

10. Put the cap on the vial. Invert the vial 3 times to mix. Put the vial in the sample vial holder.



11. Clean the sample vial with a no-lint cloth.

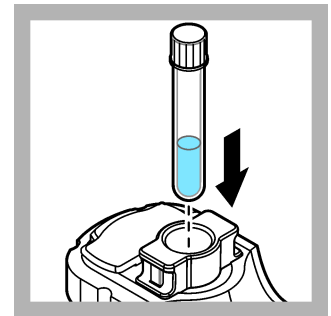

12. Put the sample vial in the vial adapter.

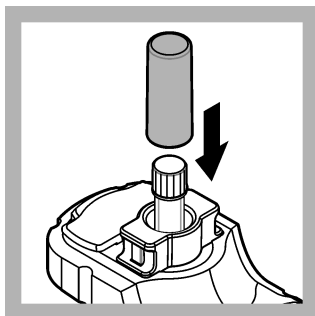

13. Put the vial cover on the sample vial.



14. Select **READ**. The results show in ppb ($\mu\text{g/L}$). If the sample temperature is higher or lower than $20 \pm 3 \text{ }^\circ\text{C}$ ($68 \pm 5 \text{ }^\circ\text{F}$), refer to [Temperature correction](#) on page 3 to calculate the actual reading.

Temperature correction

- If the sample temperature is **more** than $20 \text{ }^\circ\text{C}$ ($68 \text{ }^\circ\text{F}$):
Actual reading = reading - $[(0.014 \times \text{reading}) \times (\text{sample temperature in } ^\circ\text{C} - 20)]$
- If the sample temperature is **less** than $20 \text{ }^\circ\text{C}$ ($68 \text{ }^\circ\text{F}$):
Actual reading = reading + $[(0.014 \times \text{reading}) \times (20 - \text{sample temperature in } ^\circ\text{C})]$

Interferences

Interfering substance	Interference level
Alkalinity	More than 1000 mg/L CaCO ₃ . Adjust to pH 6–7 with 1 N Sulfuric Acid. Measure the amount to add on a separate sample aliquot, then add the same amount to the sample that is tested. Correct the test result for the dilution from the volume addition.
Bromine, Br ₂	Positive interference at all levels
Chlorine Dioxide, ClO ₂	No interference until 0.15 ppm
Chloramines, organic	May interfere
Hardness	No effect at less than 1000 mg/L as CaCO ₃ . For higher hardness samples, the sample may become cloudy after the reagents are added. However, a cloudy sample will have only a very small effect on the result.
Iodine, I ₂	Interferes at all levels.
Manganese, Oxidized (Mn ⁴⁺ , Mn ⁷⁺) or Chromium, Oxidized (Cr ⁶⁺)	Mn ⁷⁺ —Positive interference at all levels. +30 ppb positive interference for 50 ppb Mn ⁷⁺ Mn ⁴⁺ —No interference until 1.0 ppm Cr ⁶⁺ —No interference until 0.2 ppm
Monochloramine (NH ₂ Cl)	Causes a gradual drift to higher readings. When read within 1 minute after reagent addition, 300 ppb monochloramine causes less than a 2 ppb increase in the reading.
Ozone	Interferes at all levels
Highly buffered samples or extreme sample pH	Can prevent the correct pH adjustment (of the sample) by the reagents. Sample pretreatment may be necessary. Adjust to pH 6–7 with acid (Sulfuric Acid, 1 N) or base (Sodium Hydroxide, 1 N). Correct the test result for the dilution caused by the volume additions.

Reagent blank calibration

Do a reagent blank calibration before a set of new reagent bottles is used.

1. Set the instrument to on. Keep the sample port cover closed during startup.
2. After startup, make sure that the sample port is clean. Use a soft cloth or no-lint paper tissue (or air duster) to clean the sample port as necessary.
3. Install the vial adapter in the instrument. Push in the tabs on the sides of the vial adapter.
4. Select **CALIBRATION > FREE CHLORINE**.
5. Select **CAL-RB**.
6. Prepare a reagent blank. Replace the sample with deionized water (or distilled water or organic-free water) in the test procedure. Do not use the timer.
7. Clean the external surface of the sample vial with a no-lint cloth.
8. Install the sample vial in the vial adapter.
9. Put the vial cover on the sample vial.
10. Push the **Enter** key to measure the reagent blank.
11. Push the **Enter** key to save the results.
12. Immediately empty and rinse the sample vial. Rinse the sample vial and cap three times with deionized water (or distilled water).

Slope calibration check

Do a calibration check

Use the DR1300 FL Fluorescence Standards Kit to do a calibration check at regular intervals. Refer to for ordering information.

1. Make sure that the DR1300 FL Fluorescence Standards Kit is within the expiration date.
2. Get the Certificate of Analysis for the DR1300 FL Fluorescence Standards Kit. The Certificate of Analysis is available at https://app.hach.com/coaweb/customer_coa_request.asp.
3. Push **Enter** to set the instrument to on. Keep the sample port cover closed during startup.
4. After startup, make sure that the sample port is clean. Use a soft cloth or no-lint paper tissue (or air duster) to clean the sample port as necessary.
5. Install the vial adapter in the instrument. Push in the tabs on the sides of the vial adapter.
6. Select **CALIBRATION > FREE CHLORINE**.
7. Select **CALIBRATION CHECK**.
8. Measure deionized water as follows:
 - a. Fill a sample vial with deionized water.
 - b. Clean the external surface of the sample vial with a no-lint cloth.
 - c. Install the sample vial in the vial adapter.
 - d. Put the vial cover on the sample vial.
 - e. Push **Enter** to select **ZERO**.
9. Measure the Standard 1 vial as follows:
 - a. Clean the Standard 1 vial with a no-lint cloth.
 - b. Install the Standard 1 vial in the vial adapter.
 - c. Put the vial cover on the sample vial.
 - d. Push **Enter** to select **READ**.
10. Measure the Standard 2 vial as follows:
 - a. Clean the Standard 2 vial with a no-lint cloth.
 - b. Install the Standard 2 vial in the vial adapter.
 - c. Put the vial cover on the sample vial.
 - d. Push **Enter** to select **READ**.
11. If the Standard 1 reading is not within ± 2 ppb of the Free Chlorine value from the Certificate of Analysis and the Standard 2 reading is not within ± 5 ppb of the Free Chlorine value from the Certificate of Analysis, do a slope calibration. Refer to the DL1300 FL User Manual for instructions.

Method performance

The method performance data that follows was derived from laboratory tests that were measured on a DR1300 FL fluorometer during ideal test conditions. Users can get different results under different test conditions

Precision (95% confidence interval)
50.0 \pm 1.0 $\mu\text{g/L Cl}_2$

Summary of method

The buffer component in the reagents adjusts the pH of the sample. In the presence of both reagents, chlorine in the sample as hypochlorous acid or hypochlorite ion (free chlorine or free available chlorine) reacts with the non-fluorescent indicator and forms

fluorescent molecules. This increases the fluorescence intensity. The meter can calculate the free chlorine concentration based on the fluorescence intensity change.

Consumables and replacement items

Required reagents

Description	Quantity	Item no.
Reagent kit, ULR Fluorescence Free Chlorine, includes: Sample vial holder, two 16-mm vials with caps and two reagents in dropper bottles	1	34251000
Refill kit, ULR Fluorescence Free Chlorine Reagents, 100 tests, includes: Two reagents in dropper bottles	1	34251001

Required apparatus

Description	Quantity/test	Unit	Item no
Fluorescence sample vials with caps, 10-mL round, 16 mm x 100 mm	1	6/pkg	100866

Optional apparatus

Description	Unit	Item no.
Beaker, glass, 100 mL	each	50042H
Sodium Hydroxide Standard Solution, 1.0 N	100 mL MDB	104532
Sulfuric Acid Standard Solution, 1 N	100 mL MDB	127032
Pipetter, adjustable volume, 1.00–10.00 mL	each	L1089
Tips for L1089 Pipetter, 10 mL	200/pkg	L20002
Paper, pH, 0–14 pH range	100/pkg	2601300
Sample vial holder	1	3563500
Water, organic-free	500 mL	2641549
Deionized water	500 mg	27248



FOR TECHNICAL ASSISTANCE, PRICE INFORMATION AND ORDERING:
 In the U.S.A. – Call toll-free 800-227-4224
 Outside the U.S.A. – Contact the HACH office or distributor serving you.
 On the Worldwide Web – www.hach.com; E-mail – techhelp@hach.com

HACH COMPANY
 WORLD HEADQUARTERS
 Telephone: (970) 669-3050
 FAX: (970) 669-2932