



DOC023.53.90154

TSS sc
TSS W sc
TSS HT sc
TSS VARI sc
TSS XL sc
TSS TITANIUM2 sc
TSS TITANIUM7 sc

User Manual

09/2022, Edition 4

Table of contents

Section 1 Technical data	5
1.1 Dimensions	7
Section 2 General information	9
2.1 Safety information	9
2.1.1 Hazard notices in this manual	9
2.1.2 Warning labels	9
2.2 Areas of application	10
2.2.1 TSS sc/TSS W sc: 0.001 to 9999 FNU; 0.001 to 500 g/L	10
2.2.2 TSS HT sc: 0.001 to 9999 FNU; 0.001 to 500 g/L	10
2.2.3 TSS VARI sc: 0.001 9999 FNU; 0.001 up to 500 g/L.....	10
2.2.4 TSS XL sc: 0.001 to 9999 FNU; 0.001 to 500 g/L.....	10
2.2.5 TSS TITANIUM2 sc/TSS TITANIUM7 sc: 0.001 to 9999 FNU; 0.001 to 500 g/L	10
2.3 Measuring principle.....	11
2.3.1 Turbidity according to DIN standards.....	11
2.3.2 Measurement of solids according to plant-specific curves.....	11
2.4 Handling.....	11
2.5 Scope of delivery	11
2.6 Function test	11
Section 3 Installation	13
3.1 Installation overview of basin sensor	13
3.2 Pipe installation options for sensor installation	14
3.3 Connect the sensor cable	15
Section 4 Operation	17
4.1 User interface and navigation	17
4.2 Sensor setup.....	17
4.3 Sensor data logger	17
4.4 Menu structure.....	17
4.4.1 SENSOR STATUS.....	17
4.4.2 SENSOR setup	18
4.5 CALIBRATE	20
4.5.1 Calibration of the TURBIDITY (TRB) parameter	21
4.5.1.1 Select the TURBIDITY (TRB) parameter	21
4.5.1.2 FACTOR	21
4.5.1.3 OFFSET	21
4.5.1.4 1 to 3-point calibration.....	22
4.5.2 Calibration of the SOLID (TS) parameter.....	22
4.5.2.1 Select the SOLID (TS) parameter	22
4.5.2.2 FACTOR	23
4.5.2.3 1 to 3-point calibration.....	23
4.5.3 General information about calibration	24
4.5.3.1 Clear recorded points.....	24
4.5.3.2 Clear a calibration point	24

Section 5 Maintenance	25
5.1 Maintenance schedule	25
5.2 List of wearing parts	25
5.3 Clean the measurement windows	25
5.4 Replace the wiper profile	26
Section 6 Troubleshooting	27
6.1 Error messages	27
6.2 Warnings	27
Section 7 Replacement parts and accessories	29
7.1 Replacement parts	29
7.2 Accessories	29
Section 8 Limited warranty	31
Appendix A Modbus register	33

Section 1 Technical data

Subject to change.

The product has only the approvals listed and the registrations, certificates and declarations officially provided with the product. The usage of this product in an application for which it is not permitted is not approved by the manufacturer.

Measurement	
Measurement method	Combined multiple-beam alternating light technique with IR diode system and beam focus
	Turbidity (TRB) 2-channel 90° scattered light measurement in accordance with DIN/EN 27027/ISO7027, wavelength = 860 nm Additional measurement value verification through eight-channel multiple-angle measurement
	Solid matter (TS) Modified absorption measurement: Eight-channel multiple-angle measurement, wavelength = 860 nm
	Air-bubble compensation Software-based
	Measurement value compensation Software-based (process-adaptable)
Measuring range	Turbidity (TRB) 0.001 to 9999 FNU
	Solid matter (TS) 0.001 to 500 g/L
Measurement accuracy	Turbidity (TRB) Up to 1000 FNU/NTU: < 5% of measurement value ± 0.01 FNU/NTU
Reproducibility	Turbidity (TRB) < 3%
	Solid matter (TS) < 4%
Response time	1 s ≤ T90 ≤ 300 s (adjustable)
Calibration	Turbidity (TRB) Calibrated before shipping
	Solid matter (TS) To be calibrated on site by the customer
	Zero point Calibrated permanently before shipping
Environmental conditions	
Pressure range	TSS sc: ≤ 10 bar or ≤ 100 m ≤ 145 PSI
	TSS W sc: ≤ 6 bar or ≤ 60 m ≤ 87 PSI
	TSS HT sc: ≤ 10 bar or ≤ 100 m ≤ 145 PSI
	TSS VARI sc: ≤ 16 bar or ≤ 160 m ≤ 232 PSI
	TSS XL sc: ≤ 16 bar or ≤ 160 m ≤ 232 PSI
	TSS TITANIUM2 sc: ≤ 10 bar or ≤ 100 m ≤ 145 PSI
	TSS TITANIUM7 sc: ≤ 10 bar or ≤ 100 m ≤ 145 PSI
Flow speed	Max. 3 m/s (any air bubbles created affect the measurement)
Ambient temperature	TSS sc: 0 to 60 °C, briefly 80 °C 32 to 140 °F, briefly 176 °F
	TSS W sc: 0 to 50 °C, briefly 70 °C 32 to 122 °F, briefly 158 °F
	TSS HT sc: 0 to 90 °C, briefly 95 °C 32 to 194 °F, briefly 203 °F
	TSS VARI sc: 0 to 80 °C, briefly 95 °C 32 to 176 °F, briefly 203 °F
	TSS XL sc: 0 to 80 °C, briefly 95 °C 32 to 176 °F, briefly 203 °F
	TSS TITANIUM2 sc: 0 to 60 °C, briefly 80 °C 32 to 140 °F, briefly 176 °F
	TSS TITANIUM7 sc: 0 to 60 °C, briefly 80 °C 32 to 140 °F, briefly 176 °F
Distance Sensor – wall/floor	Solid matter (TS) > 10 cm, turbidity (TRB) > 50 cm

Technical data

Equipment properties											
Dimensions	Basin sensor: $\varnothing \times L$ 40 mm \times 330 mm (1.57 in \times 13 in) Installation sensor (TriClamp): $\varnothing \times L$ 40 mm \times 332 mm (1.57 in \times 13 in) TSS VARI sc, TSS XL sc: $\varnothing \times L$ 40 mm \times 232 mm (1.57 in \times 9.13 in)										
Materials	Parts in contact with medium (For TITANIUM as stipulated in order specification) <table border="0" style="width: 100%;"> <tr> <td style="width: 50%;">Head:</td> <td>stainless steel DIN 1.4460</td> </tr> <tr> <td>Sleeve, shaft, shank:</td> <td>stainless steel DIN 1.4571</td> </tr> <tr> <td>Sapphire glass</td> <td></td> </tr> <tr> <td>Gaskets:</td> <td>FKM, optional FFKM (type HT on request)</td> </tr> <tr> <td>Wipers (optional):</td> <td>PA (GF), TPV</td> </tr> </table>	Head:	stainless steel DIN 1.4460	Sleeve, shaft, shank:	stainless steel DIN 1.4571	Sapphire glass		Gaskets:	FKM, optional FFKM (type HT on request)	Wipers (optional):	PA (GF), TPV
	Head:	stainless steel DIN 1.4460									
	Sleeve, shaft, shank:	stainless steel DIN 1.4571									
	Sapphire glass										
Gaskets:	FKM, optional FFKM (type HT on request)										
Wipers (optional):	PA (GF), TPV										
TSS sc TSS W sc TSS XL sc TSS VARI sc	Sensor connection cable (permanently connected), Semoflex (PUR): 1 AWG 22/12 V DC twisted cable pair, 1 AWG 24/data twisted cable pair, shared cable screen										
TSS HT sc TSS TITANIUM sc	Sensor connection cable (permanently connected), Teflon (PTFE): 1 AWG 22/12 V DC twisted cable pair, 1 AWG 22/data twisted cable pair, shared cable shield										
Cable gland	TSS sc, TSS W sc, TSS HT sc, TSS VARI sc, TSS XL sc: Stainless steel 1.4305 TSS TITANIUM2 sc: Grade 2 titanium TSS TITANIUM7 sc: Grade 7 titanium										
Mass	Basin sensor, installation sensor (TriClamp): Approximately 1.6 kg TSS VARI sc, TSS XL sc: Approximately 1.5 kg										
Cable length	10 m (32.81 ft), max. 100 m (328 ft) with extension cable										
Other											
Inspection interval	Upon request once per year, service contract with warranty extension to 5 years										
Maintenance requirements	1 hour/month, typically										
Compliance	CE compliant										

1.1 Dimensions

Figure 1 Dimensions

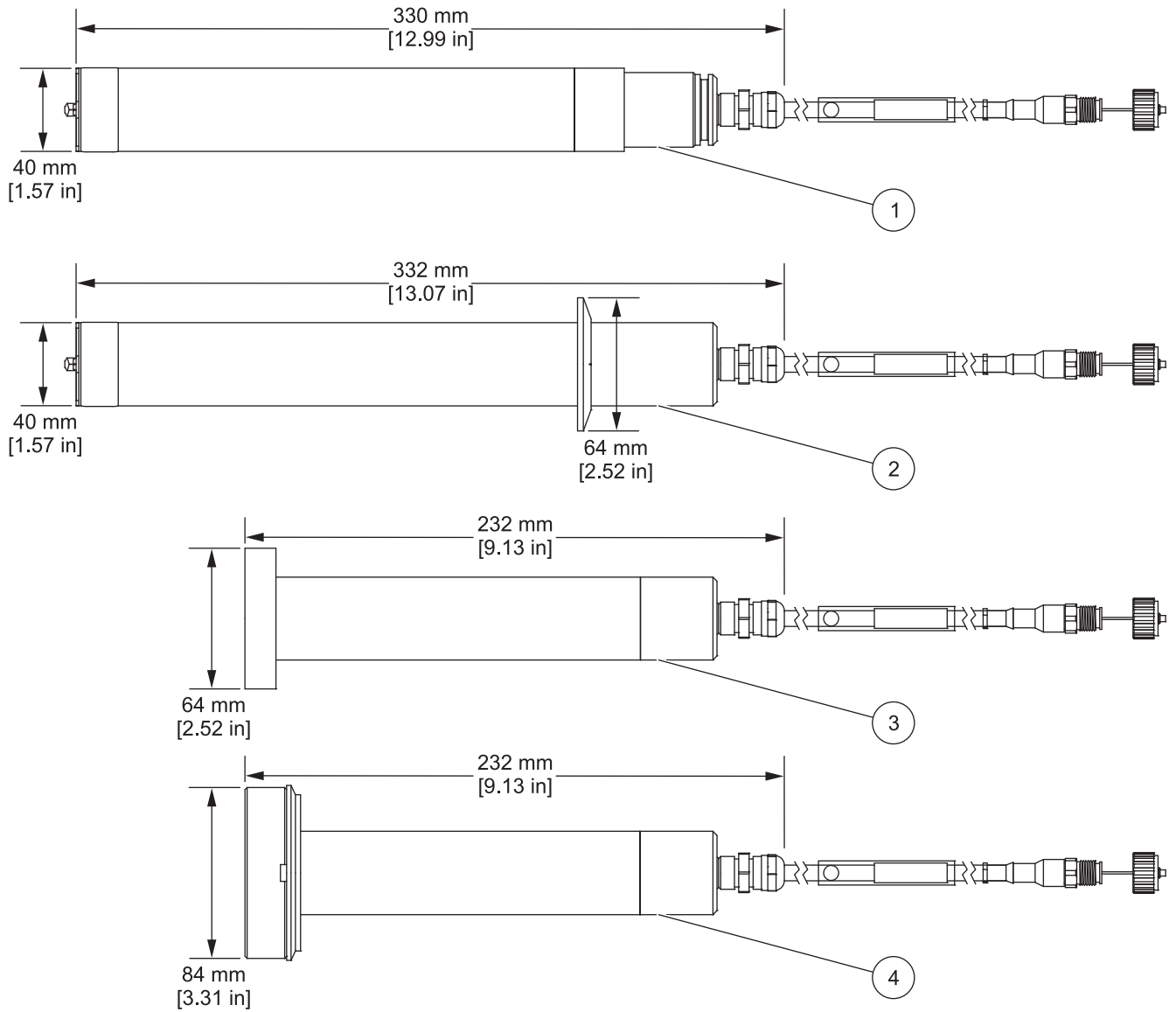

1 Basin sensor	3 TSS XL sc
2 Installation sensor (TriClamp)	4 TSS VARI sc

Section 2 General information

2.1 Safety information

Please read this entire manual before unpacking, setting up, or operating this equipment. Pay attention to all hazard and warning notices. Failure to do so could result in serious injury to the operator or damage to the equipment.

To prevent damage to or impairment of the device's protection equipment, the device may only be used or installed as described in this manual.

NOTICE

The manufacturer is not responsible for any damages due to misapplication or misuse of this product including, without limitation, direct, incidental and consequential damages, and disclaims such damages to the full extent permitted under applicable law. The user is solely responsible to identify critical application risks and install appropriate mechanisms to protect processes during a possible equipment malfunction.

⚠ DANGER

Explosion hazard. This product is not suitable for use in hazardous areas.

2.1.1 Hazard notices in this manual

⚠ DANGER

Indicates a potentially or imminently hazardous situation that, if not avoided, can result in death or serious injury.

⚠ WARNING

Indicates a potentially or imminently dangerous situation that, if it is not avoided, can lead to death or to serious injuries.

⚠ CAUTION

Indicates a possible dangerous situation that can have minor or moderate injuries as the result.



NOTICE

Indicates a situation that, if it is not avoided, can lead to damage to the device. Information that requires special emphasis.

Note: Information that supplements points in the main text.

2.1.2 Warning labels

Read all labels and tags attached to the instrument. Personal injury or damage to the instrument could occur if not observed.

	This symbol, if noted on the instrument, references the instruction manual for operation and/or safety information.
	This symbol may be found on an enclosure or barrier within the product and indicates a risk of electric shock and/or death by electrocution.

General information



Electrical equipment marked with this symbol may not be disposed of in European domestic or public disposal systems. Return old or end-of-life equipment to the manufacturer for disposal at no charge to the user.

2.2 Areas of application

Figure 2 Overview

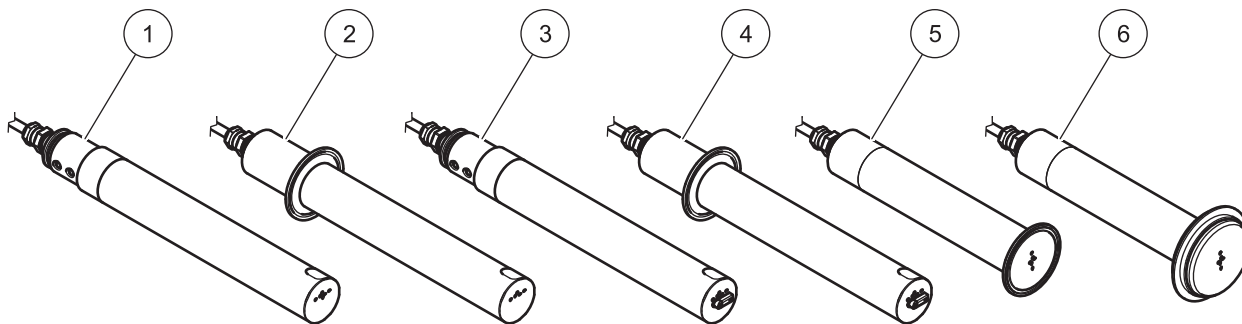

1	Basin sensor	4	Installation sensor (TriClamp) with wiper
2	Installation sensor (TriClamp)	5	TSS XL sc
3	Basin sensor with wiper	6	TSS Vari sc

2.2.1 TSS sc/TSS W sc: 0.001 to 9999 FNU; 0.001 to 500 g/L

Extremely accurate turbidity and solid sensors made from stainless steel for color-independent measurement of highly concentrated sludges.

This sensor is available in a basin version (with/without wiper) or an installation version (TriClamp) (with/without wiper) (refer to 1, 2, 3 and 4 in [Figure 2 Overview](#)).

2.2.2 TSS HT sc: 0.001 to 9999 FNU; 0.001 to 500 g/L

Extremely accurate turbidity and solid sensors made from stainless steel for color-independent measurement of highly concentrated sludges. Working temperature up to 90 °C (194 °F); up to 95 °C (203 °F) briefly.

This sensor is available in a basin version (without wiper) or an installation version (TriClamp) (without wiper) (refer to 1 and 2 in [Figure 2 Overview](#)).

2.2.3 TSS VARI sc: 0.001 9999 FNU; 0.001 up to 500 g/L

Extremely accurate turbidity and solid sensors made from stainless steel for color-independent measurement of highly concentrated sludges. This sensor connects to VARIVENT® piping systems (without wiper) (refer to 6 in [Figure 2 Overview](#)).

2.2.4 TSS XL sc: 0.001 to 9999 FNU; 0.001 to 500 g/L

Extremely accurate turbidity and solid sensors made from stainless steel for color-independent measurement of highly concentrated sludges. This sensor connects to TriClamp piping systems. (without wiper) (refer to 5 in [Figure 2 Overview](#)).

2.2.5 TSS TITANIUM2 sc/TSS TITANIUM7 sc: 0.001 to 9999 FNU; 0.001 to 500 g/L

Extremely accurate turbidity and solid sensors made from TITANIUM GRADE 2/TITANIUM GRADE 7 for color-independent measurement of highly concentrated sludges. This sensor has been specially developed for use in aggressive media and is

available in the basin or installation version (TriClamp) (without wiper) (refer to 1 and 2 in [Figure 2 Overview](#)).

2.3 Measuring principle

2.3.1 Turbidity according to DIN standards

Turbidity is measured in accordance with DIN standard EN 27027 (ISO 7027) and is calibrated by the manufacturer. Measurement is exceptionally simple and accurate.

2.3.2 Measurement of solids according to plant-specific curves

Software-based optimization routines enable extremely precise simulation of medium-specific calibration curves with few calibration points. Usually, a single calibration point is sufficient.

Up to three calibration points can be defined for a highly fluctuating medium. The combined multiple-beam alternating light technique records solids in the medium with even greater accuracy.

2.4 Handling

Do not subject the sensor to any hard mechanical impacts.

2.5 Scope of delivery

- TSS sc sensor
- Protective cap for sensor tip (depending on model)
- Test log
- User manual
- TSS sc wiper kit for 5 changes including screws and screwdriver (LZY634, optional)

2.6 Function test

After unpacking and checking for any transport damage, perform a brief function check.

1. Connect the sensor to the sc controller (refer to [3.3, page 15](#)).
2. Switch on the power supply to the sc controller.
The display is activated and the sensor enters measurement mode.

Note: *The measurement value that is shown in air is not relevant.*

3. If no warning or error messages are shown, the function check is complete.

Section 3 Installation

⚠ DANGER

Explosion hazard. The TSS sc sensors are not suitable for use in hazardous locations.

⚠ CAUTION

Personal injury hazard. The installation of this system must only be carried out by qualified experts in accordance with all local safety regulations.

Note: Depending on the area of application, the sensor may have to be installed with additional optional accessories.

3.1 Installation overview of basin sensor

Note: This system must be installed by qualified personnel.

Figure 3 Installation example with optional accessories

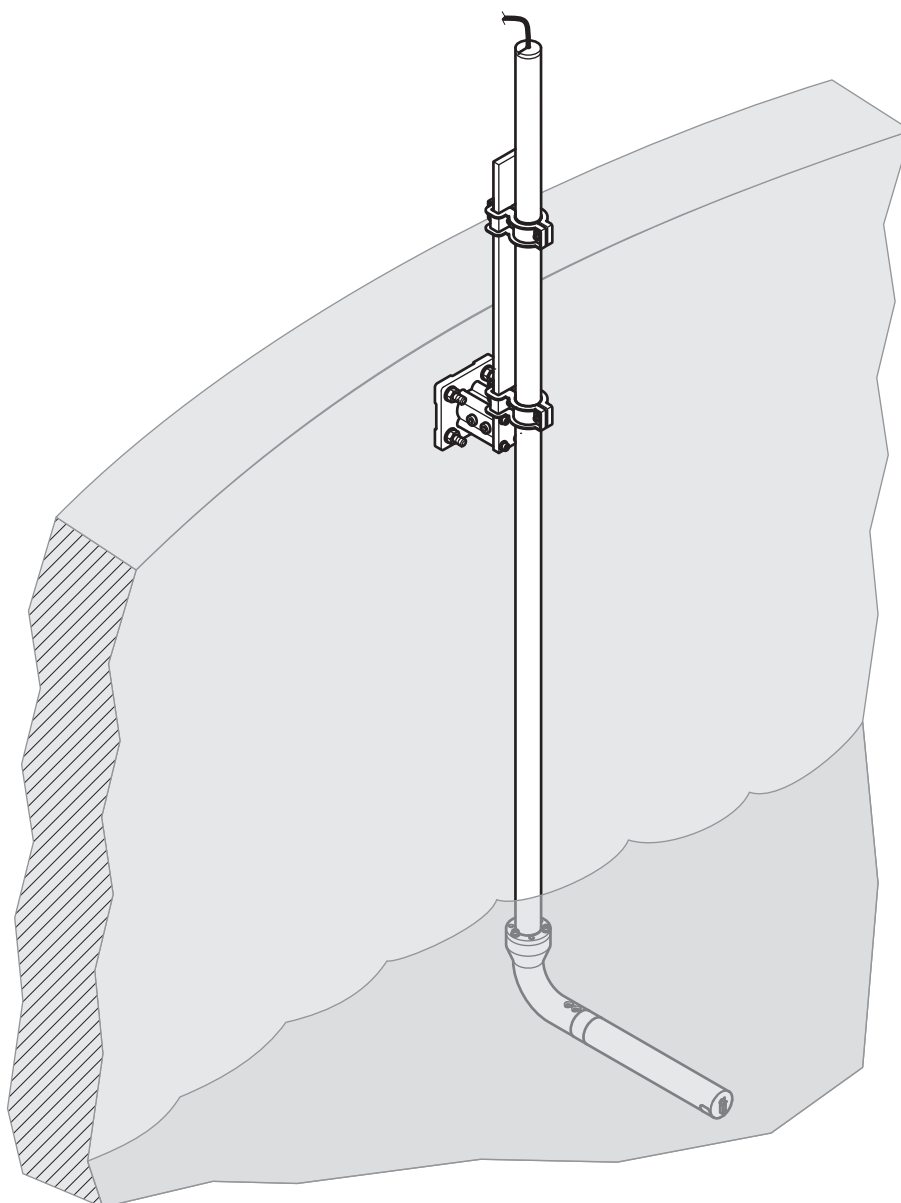

3.2 Pipe installation options for sensor installation

Figure 4 Pipe installation options with optional accessories

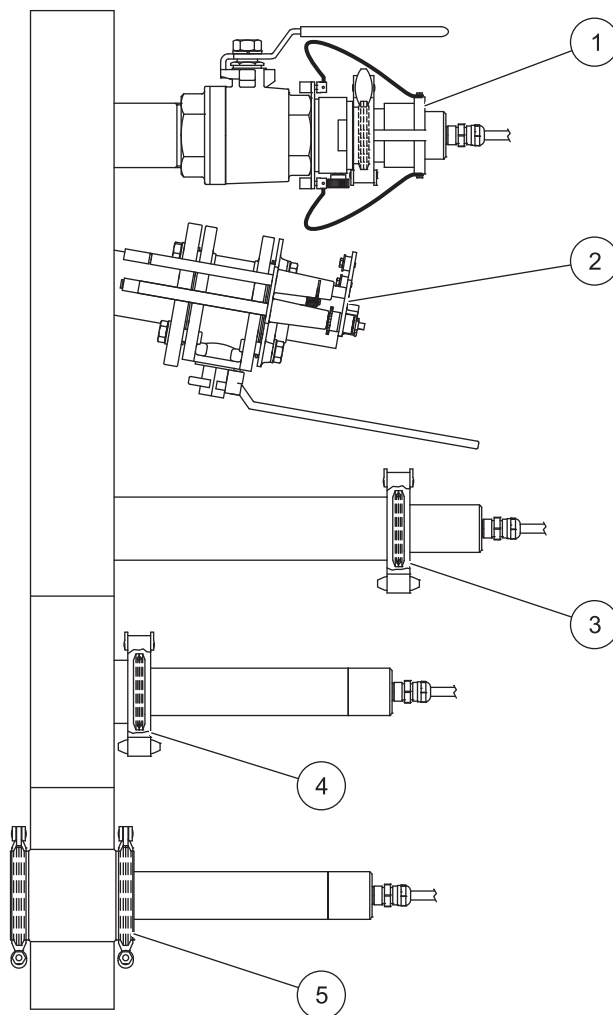

<p>1 TSS sc TriClamp with retractable ball valve fitting (maximum alternating pressure 1.5 bar; max. operating pressure 6 bar) LZU300.99.00000¹</p>	<p>4 TSS XL sc with XL LZU304.99.100x0¹ measuring tube</p>
<p>2 TSS sc Inline, TSS W sc Inline, TSS HT sc Inline with LZY630.00.1y000² safety installation fitting (max. operating pressure 6 bar)</p>	<p>5 TSS VARI sc with VARIVENT LZU304.99.000x0¹ measuring tube</p>
<p>3 TSS sc TriClamp with LZU302.99.000x0¹ welding connector</p>	

¹ x= identifier for the nominal diameter of the pipe

² y= identifier for the material selection of the associated connecting flange

3.3 Connect the sensor cable

⚠ CAUTION

Personal injury hazard. Always lay cables and hoses so that they are straight and do not pose a tripping hazard.

1. Unscrew the protective caps from the controller socket and the cable plug and retain them.
2. Pay attention to the guide in the plug and push the plug into the socket.
3. Tighten the nut by hand.

Note: Extension cables are available in various lengths (refer to [Section 7 Replacement parts and accessories](#)).

Maximum cable length 100 m (328 ft).

Figure 5 Connect the sensor plug to the controller

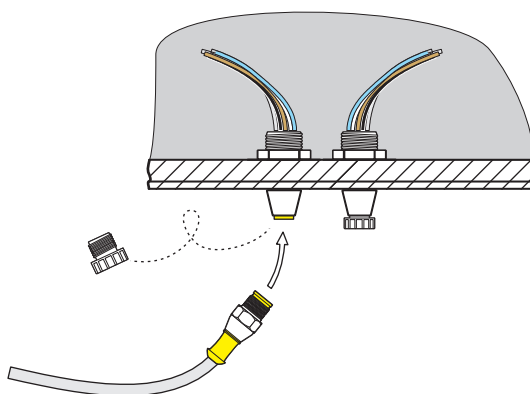

Installation

Figure 6 Pin configuration

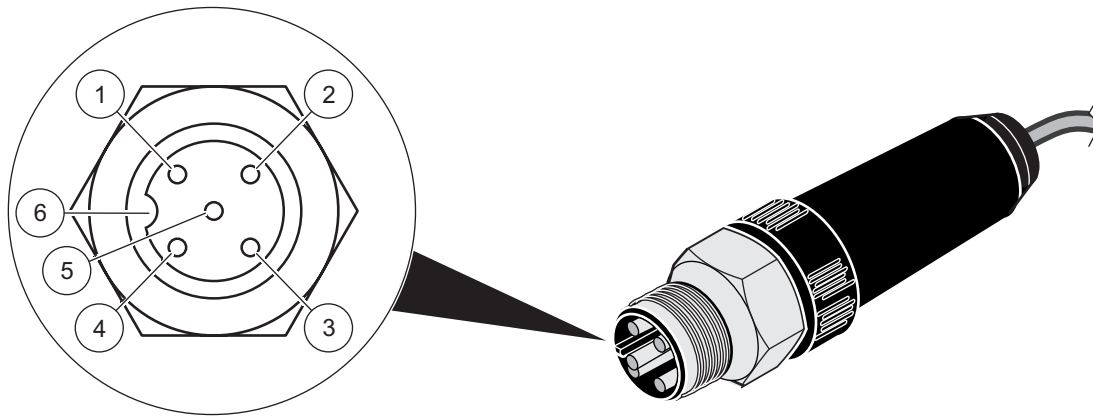

Number	Description	Standard cable, cable color	Teflon cable, cable color
1	+12 VDC	Brown	Pink
2	Earth	Black	Gray
3	Data (+)	Blue	Brown
4	Data (-)	White	White
5	Shield	Shield (gray)	Shield (gray)
6	Guide		

Section 4 Operation

4.1 User interface and navigation

The sensor can be operated with all sc controllers. Refer to the controller documentation for keypad description and navigation information.

4.2 Sensor setup

When the sensor is connected for the first time, the sensor serial number is displayed as the name of the sensor. To change the sensor name:

1. Open the MAIN MENU.
2. Select SENSOR SETUP and confirm.
3. Select the corresponding sensor and confirm.
4. Select CONFIGURE and confirm.
5. Select EDIT and confirm.
6. Edit the name and confirm to return to the CONFIGURE menu.

Complete sensor configuration in the same manner, with the following menu options selected:

- MEAS UNITS
 - PARAMETERS
 - CLEAN. INTERVAL
 - RESPONSE TIME
 - LOGGER INTERVAL
7. Go back to the MAIN MENU or the measurement mode display.

4.3 Sensor data logger

There is a data log and event log available for each sensor. The data memory is used to store measurement data at preset intervals; the event memory stores events such as configuration changes, alarms and warning conditions. Both logs can be exported to CSV format (refer to the controller manual).

4.4 Menu structure

4.4.1 SENSOR STATUS

SELECT SENSOR (if there is more than one sensor)	
ERROR LIST	Possible error messages: MEAS OVERRANGE, CAL. INSUFF. +/-, ZERO, CAL REQUIRED, EE RSRVD ERR, ERROR PROBE, LED FAILURE
WARNING LIST	Possible warning messages: REPLACE PROFILE, TEST/MAINT, GASKET

Note: Refer to [Section 6 Troubleshooting](#) for a list of all possible error and warning messages together with a description of all necessary countermeasures to be taken.

Operation

4.4.2 SENSOR setup

SELECT SENSOR (if there is more than one sensor)	
WIPE	Triggers a wiping operation
CALIBRATE (turbidity)	
SET OUTMODE	Behavior of the outputs during calibration and zero point adjustment
HOLD	
ACTIVE	
SET TRANSFER	
SELECTION	
SENSOR MEASURE	Current, uncorrected measurement value
FACTOR	Can be set from 0.10 to 10.00; a detailed description is provided in section 4.5 CALIBRATE
OFFSET	Can be set from -100 to +100, a detailed description is provided in section 4.5 CALIBRATE
CALIBRATE	
MEMORY	
POINT 1	Calibration point 1 is recorded
POINT 2	Calibration point 2 is recorded
POINT 3	Calibration point 3 is recorded
CLEAR MEMORY	Clears the recorded values for all points.
POINT 1	Current calibration for point 1
POINT 2	Current calibration for point 2
POINT 3	Current calibration for point 3
SET CAL DEFLT	Security prompt, reset to default calibration
CALIBRATE (TS content)	
SET OUTMODE	Behavior of the outputs during calibration and zero point adjustment
HOLD	
ACTIVE	
SET TRANSFER	
SELECTION	
SENSOR MEASURE	Current, uncorrected measurement value
FACTOR	Can be set from 0.10 to 10.00; detailed description in section 4.5 CALIBRATE
CALIBRATE	
MEMORY	
POINT 1	Calibration point 1 is recorded
POINT 2	Calibration point 2 is recorded
POINT 3	Calibration point 3 is recorded
CLEAR MEMORY	Clears the recorded value for all points.
POINT 1	Current calibration for point 1
POINT 2	Current calibration for point 2
POINT 3	Current calibration for point 3
SET CAL DEFLT	Security prompt, all calibration points are cleared

4.4.2 SENSOR setup

SELECT SENSOR (if there is more than one sensor)	
CONFIGURE	
EDIT NAME	Name can include up to 16 characters, FACTORY CONFIG: device number
MEAS UNITS	TRB: (FNU, EBC, TE/F, NTU, FTU) TS: (mg/L, g/L, ppm, %) FACTORY CONFIG: FNU
PARAMETERS	TRB, TS, FACTORY CONFIG: TRB
CLEAN. INTERVAL	15 min, 30 min, 1 h, 4 h, 12 h, 1 day, 3 days, 7 days, FACTORY CONFIG: 4 h
RESPONSE TIME	1 to 300 s, DEFAULT CONFIG: 60 s
LOGGER INTERVAL	10 s, 30 s, 1 min, 2 min, 3 min, 4 min, 5 min, 6 min, 10 min, 15 min, 30 min, FACTORY CONFIG: 10 min
SET DEFAULTS	Security prompt, reset to default configuration for all menu options listed above.

Operation

4.4.2 SENSOR setup

SELECT SENSOR (if there is more than one sensor)	
TEST/MAINT	
PROBE INFO	
SENSOR NAME	Device name
EDITED NAME	
SERIAL NUMBER	
TURBIDITY	0.001 to 9999 FNU
SOLID	0.001 to 500 g/L
MODEL NUMBER	Item no. Sensor
CODE VERS	Sensor software
PROFILE	
PROFILE COUNTER	Counter 20,000 backwards
RESET CONFIG	MANUAL RESET, security prompt
COUNTERS	MANUAL RESET. PRESS ENTER: security prompt TEST/MAINT: COUNTER X DAYS BACKWARDS, GASKET (GASK.): COUNTER X DAYS BACKWARDS, TOTAL: OPERATING HOURS COUNTER, MOTOR: WIPE CYCLE COUNTER
INTERVAL	Default for maintenance counter
SERVICE	
WIPE	
SIGNALS	Explanation: refer to service manual
S5E1	
S5E3	
S6E1	
S6E3	
S5E2	
S5E4	
S6E2	
S6E4	
SET OUTMODE	Equipment output behavior in the SERVICE menu
HOLD	
ACTIVE	
SET TRANSFER	
SELECTION	
	Service access

4.5 CALIBRATE

Note: Turbidity measurement has been calibrated by the manufacturer — it does not need to be calibrated again.

Note: It is imperative to calibrate for solid matter measurement (refer to section [4.5.2 Calibration of the SOLID \(TS\) parameter](#)).

The zero point for turbidity and solid matter measurement has been set in the sensors by the manufacturer.

Installation conditions in the pipes can cause interfering ground reflection when measuring turbidity, which in turn may cause the zero point to shift. Compensate for this effect with an offset correction (section 4.5.1.3 **OFFSET**). If there are deviations that are unrelated to the factors described above between the measurement values shown and the laboratory results, the slope of the calibration curve can be adjusted using a factor (refer to section 4.5.1 **Calibration of the TURBIDITY (TRB) parameter**).

At least a 1-point calibration must be carried out for a solid matter measurement. In difficult application conditions, a 2-point or 3-point calibration may be necessary (refer to section 4.5.2 **Calibration of the SOLID (TS) parameter**).

4.5.1 Calibration of the TURBIDITY (TRB) parameter

Before the sensor can be calibrated to the TURBIDITY (TRB) parameter, the parameter must be selected.

4.5.1.1 Select the TURBIDITY (TRB) parameter

1. Open the MAIN MENU.
2. Select SENSOR SETUP and confirm.
3. Select the corresponding sensor and confirm.
4. Select CONFIGURE and confirm.
5. Select PARAMETERS and confirm.
6. Select the TRB parameter and confirm.
7. Go back to the MAIN MENU or the measurement mode display.

4.5.1.2 FACTOR

1. Open the MAIN MENU.
2. Select SENSOR SETUP and confirm.
3. Select the corresponding sensor and confirm.
4. Select CALIBRATE and confirm.
5. Select FACTOR and confirm.
6. Set the desired factor and confirm.
7. Go back to the MAIN MENU or the measurement mode display.

4.5.1.3 OFFSET

1. Open the MAIN MENU.
2. Select SENSOR SETUP and confirm.
3. Select the corresponding sensor and confirm.
4. Select CALIBRATE and confirm.
5. Press OFFSET and confirm.
6. Set the desired offset and confirm.
7. Go back to the MAIN MENU or the measurement mode display.

4.5.1.4 1 to 3-point calibration

Note: The turbidity measurement has been calibrated by the manufacturer.

Note: Before the sensor can be calibrated to the TRB parameter, the parameter must be selected (refer to 4.5.1.1 Select the TURBIDITY (TRB) parameter).

1. Open the MAIN MENU.
2. Select SENSOR SETUP and confirm.
3. Select the corresponding sensor and confirm.
4. Select CALIBRATE and confirm.
5. Select CALIBRATE and confirm.
6. Select MEMORY and confirm.
7. Select POINT... (point 1, 2 or 3) and confirm.

Once the calibration point has been recorded by the probe, a mark "<<" is shown after the point or points that has/have been recorded for approximately 3 seconds.

Note: If the Calibrate menu is closed and then opened again before the calibration is complete, the "<<" mark is shown again. This indicates that the calibration for this point/these points has not yet been completed. The old calibration values are still being used.

8. Select the recorded POINT and confirm.
9. Enter the laboratory comparison value and confirm.
To record more calibration points, repeat steps 6 to 9.
10. Go back to the MAIN MENU or the measurement mode display.

The instrument automatically sorts the saved calibration points according to the size of the calibration values, irrespective of the sequence in which the calibration points were recorded.

- Point 1 is always assigned to the smallest calibration value.
- Point 2 is assigned to the next smallest calibration value.
- Point 3 is assigned to the largest calibration value.

The value calculated in the laboratory can be corrected at any time by overwriting it.

4.5.2 Calibration of the SOLID (TS) parameter

Before the probe can be calibrated to the SOLID (TS) parameter, the parameter must be selected.

4.5.2.1 Select the SOLID (TS) parameter

1. Open the MAIN MENU.
2. Select SENSOR SETUP and confirm.
3. Select the corresponding sensor and confirm.
4. Select CONFIGURE and confirm.
5. Select PARAMETERS and confirm.
6. Select the parameter TS and confirm.
7. Go back to the MAIN MENU or the measurement mode display.

4.5.2.2 FACTOR

1. Open the MAIN MENU.
2. Select SENSOR SETUP and confirm.
3. Select the corresponding sensor and confirm.
4. Select CALIBRATE and confirm.
5. Select FACTOR and confirm.
6. Set the desired factor and confirm.
7. Go back to the MAIN MENU or the measurement mode display.

4.5.2.3 1 to 3-point calibration

Note: It is imperative to calibrate for solid measurement (refer to section 4.5.2 Calibration of the SOLID (TS) parameter).

Note: Before the sensor can be calibrated to the TS parameter, the parameter must be selected (refer to 4.5.2.1 Select the SOLID (TS) parameter).

1. Open the MAIN MENU.
2. Select SENSOR SETUP and confirm.
3. Select the corresponding sensor and confirm.
4. Select CALIBRATE and confirm.
5. Select CALIBRATE and confirm.
6. Select MEMORY and confirm.
7. Select POINT... (point 1, 2 or 3) and confirm.

Note: Points 2 and 3 are not shown unless point 1 or points 1 and 2 have already been recorded.

Note: This comparison is made from a grab sample and not a known standard.

Once the calibration point has been recorded by the probe, a mark "<<" is shown after the point or points that has/have been recorded for approximately 3 seconds.

Note: If the Calibrate menu is closed and then opened again before the calibration is complete, the "<<" mark is shown again. This indicates that the calibration for this point/these points has not yet been completed. The old calibration values are still being used.

8. Remove a sample and determine the solid matter content in the laboratory.
9. Select the recorded POINT and confirm.
10. Enter the laboratory comparison value and confirm.
To record more calibration points, repeat steps 6 to 10.
11. Go back to the MAIN MENU or the measurement mode display.

The instrument automatically sorts the saved calibration points according to the size of the calibration values, irrespective of the sequence in which the calibration points were recorded.

- Point 1 is always assigned to the smallest calibration value.
- Point 2 is assigned to the next smallest calibration value.
- Point 3 is assigned to the largest calibration value.

The value calculated in the laboratory can be corrected at any time by overwriting it.

4.5.3 General information about calibration

4.5.3.1 Clear recorded points

Points that have been saved under MEMORY can be reset and cleared at any time.

1. Open the MAIN MENU.
2. Select SENSOR SETUP and confirm.
3. Select the corresponding sensor and confirm.
4. Select CALIBRATE and confirm.
5. Select CALIBRATE and confirm.

A mark "<<" is shown after the recorded point or points for approximately 3 seconds.

6. Select MEMORY and confirm.
7. Select CLEAR MEMORY and confirm.

The sensor will continue working with the old calibration values.

8. Go back to the MAIN MENU or the measurement mode display.

4.5.3.2 Clear a calibration point

An individual calibration point can be cleared at any time by entering the value 0.0 for the concentration.

1. Open the MAIN MENU.
2. Select SENSOR SETUP and confirm.
3. Select the corresponding sensor and confirm.
4. Select CALIBRATE and confirm.
5. Select CALIBRATE and confirm.
6. Select the POINT to be cleared and confirm.
7. Enter the value 0 and confirm.
8. Go back to the MAIN MENU or the measurement mode display.

Section 5 Maintenance

The cleanliness of the measurement windows in the sensor head is critical for the accuracy of the measurement results!

Check the measurement windows for dirt and the wiper profile for wear once a month.

⚠ WARNING

Multiple hazards. Do not disassemble the instrument for maintenance or service. If the internal components must be cleaned or repaired, contact the manufacturer.

⚠ CAUTION

Personal injury hazard. Only qualified personnel should conduct the tasks described in this section of the manual.

NOTICE

The gaskets on the wiper shaft must be replaced yearly!
Failure to replace the gaskets regularly, could result in moisture ingress into the sensor head and lead to irreparable damage to the device.

5.1 Maintenance schedule

Maintenance task	Maintenance interval
Visual inspection	Monthly
Check calibration	Monthly (depending on environmental conditions)
Inspection	Every six months (counter)
Replace wiper shaft gaskets	Every year (counter)
Replace wiper profile	As indicated by counter (20,000 cycles)

5.2 List of wearing parts

Number	Designation	Average service life*
1	Wiper sets	1 year (with normal sand loading)
1	Gasket set including wiper shaft	1 year

* When operated in line with manufacturer settings and used appropriately

5.3 Clean the measurement windows

⚠ WARNING

Chemical hazard. Always follow appropriate safety procedures when chemicals are handled. Always wear all personal protective equipment appropriate to the chemicals used.

- Safety glasses
- Gloves
- Overalls

The measurement windows are made of sapphire glass. The measurement windows can be cleaned with any conventional cleaning agent and a soft cloth.

In the case of stubborn deposits, the use of 5% hydrochloric acid is recommended.

5.4 Replace the wiper profile

Note: The service life of the wiper profiles depends on the number of cleaning cycles carried out and the type of deposits to be removed.

1. Open the MAIN MENU.
2. Select SENSOR SETUP and confirm.
3. Select the corresponding sensor and confirm.
4. Select TEST/MAINT and confirm.
5. Select PROFILE; replace the wiper profile as described in [Figure 7](#).

Note: Make sure that the wiper is within the tolerance range shown.

6. Select RESET and confirm.
7. Confirm MANUAL RESET. ARE YOU SURE?
8. Go back to the MAIN MENU or the measurement mode display

Figure 7 Wiper replacement

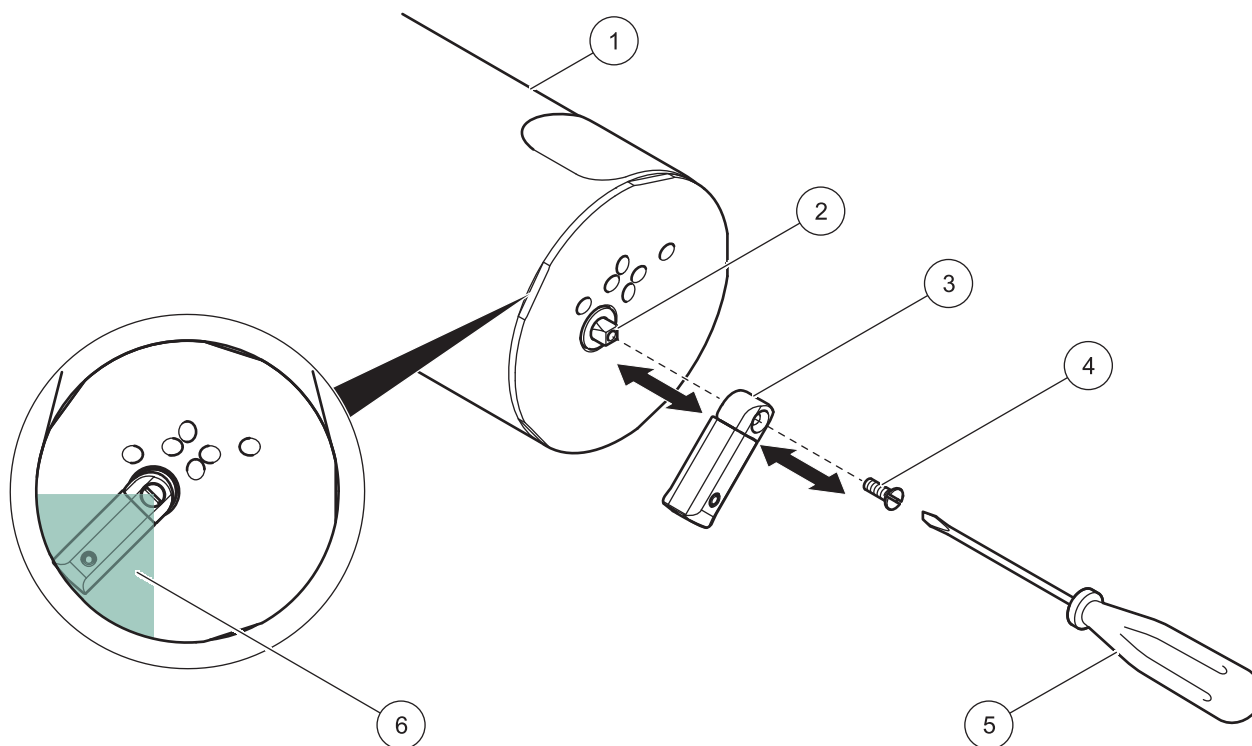

1	Sensor	4	Screw, torque 15 Ncm
2	Wiper shaft	5	Screw driver
3	Wiper	6	Tolerance range for wiper replacement

Section 6 Troubleshooting

6.1 Error messages

Possible sensor errors are shown by the controller.

Table 1 Error messages

Error displayed	Cause	Resolution
MEAS OVERRANGE	Measurement range exceeded, signals too small, probe can no longer measure this concentration	If error occurs more frequently, find another installation location
CAL. INSUFF. --	Calibration insufficient	Probe requires another calibration point in a lower concentration
CAL. INSUFF. +	Calibration insufficient	Probe requires another calibration point in a higher concentration
ZERO	Calibration is too close to the zero point	Calibrate again with higher concentration
CAL REQUIRED	No existing calibration	Calibrate probe
EE RSRVD ERR	Error in the probe electronics	Call the manufacturer's customer service department
ERROR PROBE	Error in the probe electronics	Call the manufacturer's customer service department
LED FAILURE	Faulty LED	Call the manufacturer's customer service department

6.2 Warnings

Possible sensor warnings are shown by the controller.

Table 2 Warnings

Warning shown	Cause	Resolution
REPLACE PROFILE	Counter at zero	Replace wiper profile, reset counter
TEST/MAINT	Counter expired	Call the manufacturer's customer service department
GASKET	Counter expired	Call the manufacturer's customer service department

Section 7 Replacement parts and accessories

7.1 Replacement parts

Description	Cat. No
Wiper set (for five replacements with screws and screwdriver)	LZY634
Wiper shaft maintenance kit (consisting of wiper, two-piece wiper shaft and gaskets)	LZY635
Manual, xx = language code	DOC023.xx.90154

7.2 Accessories

Description	Cat. No
Silicone gasket for TriClamp fitting	LZY653
PTFE gasket for TriClamp fitting	LZY654
FKM Gasket for TriClamp fitting	LZY655
Two-piece clip with thumb screw for TriClamp fitting	LZY656
Three-piece clip with thumb screw for TriClamp fitting (for use with PTFE gasket)	LZY657
Cable extension kit (5 m/16.40 ft)	LZX848
Cable extension kit (10 m/32.81 ft)	LZX849
Cable extension kit (15 m/49.21 ft)	LZX850
Cable extension kit (20 m/65.62 ft)	LZX851
Cable extension kit (30 m/98.43 ft)	LZX852
Cable extension kit (50 m/164.04 ft)	LZX853
Sensor bracket including 90° adapter	LZX414.00.10000
<i>Consisting of:</i>	
Base	ATS010
Mounting attachment	HPL061
Holding clamp (2x)	LZX200
Assembly pipe 2 m	BRO075
HS small parts set	LZX416
1.8 m extension pipe	LZY414
1.0 m extension pipe	LZY413
Second attachment point (including holding clamp)	LZX456
90° sensor adapter	AHA034
Set of small parts for securing sensor	LZX417
90° base	ATS011
Retractable ball valve fitting for all TSS sc TriClamp sensors (except TITANIUM, VARI & XL)	LZU300.99.00000
DN65 measuring tube for TSS VARI sc	LZU304.99.00010
DN80 measuring tube for TSS VARI sc	LZU304.99.00020
DN100 measuring tube for TSS VARI sc	LZU304.99.00030
DN125 measuring tube for TSS VARI sc	LZU304.99.00040
DN65 measuring tube for TSS XL sc	LZU304.99.10010
DN80 measuring tube for TSS XL sc	LZU304.99.10020
DN100 measuring tube for TSS XL sc	LZU304.99.10030
DN125 measuring tube for TSS XL sc	LZU304.99.10040
DN150 measuring tube for TSS XL sc	LZU304.99.10050
DN200 measuring tube for TSS XL sc	LZU304.99.10060
DN250 measuring tube for TSS XL sc	LZU304.99.10070

Replacement parts and accessories

7.2 Accessories

Description	Cat. No
Unprocessed welding connector for all TSS sc TriClamp sensors (except VARI & XL)	LZU302.99.00000
DN65 welding connector for all TSS sc TriClamp sensors (except VARI & XL)	LZU302.99.00010
DN80 welding connector for all TSS sc TriClamp sensors (except VARI & XL)	LZU302.99.00020
DN100 welding connector for all TSS sc TriClamp sensors (except VARI & XL)	LZU302.99.00030
DN125 welding connector for all TSS sc TriClamp sensors (except VARI & XL)	LZU302.99.00040
DN150 welding connector for all TSS sc TriClamp sensors (except VARI & XL)	LZU302.99.00050
DN200 welding connector for all TSS sc TriClamp sensors (except VARI & XL)	LZU302.99.00060
DN250 welding connector for all TSS sc TriClamp sensors (except VARI & XL)	LZU302.99.00070
Unprocessed welding connector for TSS XL sc	LZU302.99.10000
DN65 welding connector for TSS XL sc	LZU302.99.10010
DN80 welding connector for TSS XL sc	LZU302.99.10020
DN100 welding connector for TSS XL sc	LZU302.99.10030
DN125 welding connector for TSS XL sc	LZU302.99.10040
DN150 welding connector for TSS XL sc	LZU302.99.10050
DN200 welding connector for TSS XL sc	LZU302.99.10060
DN250 welding connector for TSS XL sc	LZU302.99.10070
Welding connector for all TSS sc TriClamp sensors (except VARI & XL)	LZU303.99.00000
6-bar safety installation fitting with stainless steel flange for TSS sc Inline, TSS W sc Inline and TSS HT sc Inline	LZY630.00.10000
6-bar safety installation fitting with carbon steel flange for TSS sc Inline, TSS W sc Inline and TSS HT sc Inline	LZY630.00.11000
6-bar safety installation fitting without flange for TSS sc Inline, TSS W sc Inline and TSS HT sc Inline	LZY630.00.12000

Section 8 Limited warranty

Hach Company warrants its products to the original purchaser against any defects that are due to faulty material or workmanship for a period of one year from date of shipment unless otherwise noted in the product manual.

In the event that a defect is discovered during the warranty period, Hach Company agrees that, at its option, it will repair or replace the defective product or refund the purchase price excluding original shipping and handling charges. Any product repaired or replaced under this warranty will be warranted only for the remainder of the original product warranty period.

This warranty does not apply to consumable products such as chemical reagents; or consumable components of a product, such as, but not limited to, lamps and tubing.

Contact Hach Company or your distributor to initiate warranty support. Products may not be returned without authorization from the Hach Company.

Limitations

This warranty does not cover:

- Damage caused by acts of God, natural disasters, labor unrest, acts of war (declared or undeclared), terrorism, civil strife or acts of any governmental jurisdiction
- Damage caused by misuse, neglect, accident or improper application or installation
- Damage caused by any repair or attempted repair not authorized by the Hach Company
- Any product not used in accordance with the instructions furnished by the Hach Company
- Freight charges to return merchandise to the Hach Company
- Freight charges on expedited or express shipment of warranted parts or products
- Travel fees associated with on-site warranty repair

This warranty contains the sole express warranty made by the Hach Company in connection with its products. All implied warranties, including without limitation, the warranties of merchantability and fitness for a particular purpose, are expressly disclaimed.

Some states within the United States do not allow the disclaimer of implied warranties and if this is true in your state the above limitation may not apply to you. This warranty gives you specific rights, and you may also have other rights that vary from state to state.

This warranty constitutes the final, complete, and exclusive statement of warranty terms and no person is authorized to make any other warranties or representations on behalf of Hach Company.

Limitation of Remedies

The remedies of repair, replacement or refund of purchase price as stated above are the exclusive remedies for the breach of this warranty. On the basis of strict liability or under any other legal theory, in no event shall the Hach Company be liable for any incidental or consequential damages of any kind for breach of warranty or negligence.

Appendix A Modbus register

Table 3 Sensor Modbus registers

Tag name	Group name	Register	Data type	Length	R/W	Description
TURBIDITY FNU	Measurement	40001	Float	2	R	Turbidity in FNU
TURBIDITY NTU	Measurement	40001	Float	2	R	Turbidity in NTU
TURBIDITY TEF	Measurement	40001	Float	2	R	Turbidity in TEF
TURBIDITY FTU	Measurement	40001	Float	2	R	Turbidity in FTU
TURBIDITY EBC	Measurement	40003	Float	2	R	Turbidity in EBC
SOLID mg/L	Measurement	40005	Float	2	R	Solid in mg/L
SOLID ppm	Measurement	40005	Float	2	R	Solid in ppm
SOLID g/L	Measurement	40007	Float	2	R	Solid in g/L
SOLID %	Measurement	40009	Float	2	R	Solid in percent
Reserved	Reserved	40011	Unsigned integer	1	R	Spare
SET PARAMETER	Configuration	40012	Unsigned integer	1	R/W	Parameter
UnitTM	Unit	40013	Unsigned integer	1	R/W	Turbidity unit
UnitDS	Unit	40014	Unsigned integer	1	R/W	Solid unit
OFFSET	Calibration	40015	Float	2	R/W	Turbidity offset
Factor TRB	Calibration	40017	Float	2	R/W	Turbidity factor
Factor TS	Calibration	40019	Float	2	R/W	Solid factor
Reserved	Reserved	40021	Unsigned integer	1	R	Reserved
RESPONSE TIME	Configuration	40022	Unsigned integer	1	R/W	Response time
CLEAN. INTERVAL	Configuration	40023	Unsigned integer	1	R/W	Cleaning interval
LOGGER INTERVAL	Configuration	40024	Unsigned integer	1	R/W	Logger interval
Outputmodekal	Service	40025	Unsigned integer	1	R/W	Output mode "Calibrate"
Outputmodesrv	Service	40026	Unsigned integer	1	R/W	Output mode "Service"
EDITED NAME	Configuration	40027	String	8	R/W	Measurement location
PROFILE COUNTER	Configuration	40035	Unsigned integer	1	R/W	Profile counter
SERIAL NUMBER	Configuration	40036	String	6	R/W	Serial number
CAL. DATE	Configuration	40042	Time2	2	R	Date of factory calibration
TURBIDITY	Calibration	40044	Float	2	R	Turbidity sensor measurement value
SOLID	Calibration	40046	Float	2	R	Solid sensor measurement value
PROGRAM	Maintenance	40048	Float	2	R	Application version
BOOTPROGR.	Maintenance	40050	Float	2	R	Bootloader version
STRUCTURE	Maintenance	40052	Unsigned integer	1	R	Structure driver version
FIRMWARE	Maintenance	40053	Unsigned integer	1	R	Register driver version
CONTENT	Maintenance	40054	Unsigned integer	1	R	Firmware driver version
FormatMinFNU	Configuration	40055	Float	2	R	Turbidity lower limit in FNU
FormatMaxFNU	Configuration	40057	Float	2	R	Turbidity upper limit in FNU
FormatMinEBC	Configuration	40059	Float	2	R	Turbidity lower limit in EBC
FormatMaxEBC	Configuration	40061	Float	2	R	Turbidity upper limit in EBC
FormatMinGL	Configuration	40063	Float	2	R	Solid lower limit in g/L
FormatMaxGL	Configuration	40065	Float	2	R	Solid upper limit in g/L
FormatMinMGL	Configuration	40067	Float	2	R	Solid lower limit in mg/L
FormatMaxMGL	Configuration	40069	Float	2	R	Solid upper limit in mg/L
FormatMinPR	Configuration	40071	Float	2	R	Solid upper limit in percent

Table 3 Sensor Modbus registers(Continued)

Tag name	Group name	Register	Data type	Length	R/W	Description
FormatMaxPR	Configuration	40073	Float	2	R	Solid upper limit in percent
S5E1	Maintenance	40075	Float	2	R	Signal LED S5E1
S5E3	Maintenance	40077	Float	2	R	Signal LED S5E3
S6E1	Maintenance	40079	Float	2	R	Signal LED S6E1
S6E3	Maintenance	40081	Float	2	R	Signal LED S6E3
S5E2	Maintenance	40083	Float	2	R	Signal LED S5E2
S5E4	Maintenance	40085	Float	2	R	Signal LED S5E4
S6E2	Maintenance	40087	Float	2	R	Signal LED S6E2
S6E4	Maintenance	40089	Float	2	R	Signal LED S6E4

HACH COMPANY World Headquarters

P.O. Box 389, Loveland, CO 80539-0389 U.S.A.
Tel. (970) 669-3050
(800) 227-4224 (U.S.A. only)
Fax (970) 669-2932
orders@hach.com
www.hach.com

HACH LANGE GMBH

Willstätterstraße 11
D-40549 Düsseldorf, Germany
Tel. +49 (0) 2 11 52 88-320
Fax +49 (0) 2 11 52 88-210
info-de@hach.com
www.de.hach.com

HACH LANGE Sàrl

6, route de Compois
1222 Vérenaz
SWITZERLAND
Tel. +41 22 594 6400
Fax +41 22 594 6499

