



Catalog Number 4979

# **911/940 Intrinsically Safe Flow Meters**

USER MANUAL

January 2010, Edition 12

---

---

<b>Section 1 Specifications</b> .....	3
<b>Section 2 General Information</b> .....	7
2.1 Safety Information .....	7
2.1.1 Use of Hazard Information .....	7
2.1.2 Precautionary Labels .....	7
2.1.3 Hazardous Locations .....	8
2.1.4 Intrinsically Safe Equipment .....	8
2.1.5 Confined Space Entry .....	10
<b>Section 3 Getting Started</b> .....	13
3.1 Installing the Flow Meter-Considerations .....	13
3.1.1 Choosing the Proper Site .....	13
3.1.2 Dealing with Difficult Sites .....	13
3.1.3 Choosing the Appropriate Meter and Sensor Combination .....	13
<b>Section 4 Meter Installation</b> .....	15
4.1 Approved 911 and 940 Installation Drawings .....	15
4.3 Installing the Batteries .....	30
4.3.1 Installing the Battery Pack in the 940 .....	30
4.3.2 Installing the Battery Pack in the 911 .....	31
4.3.3 Battery Compartment Desiccant .....	32
4.3.4 Estimating the Battery Life .....	32
4.3.5 Recharging the Lithium Ion Battery Pack for Model 940 .....	33
4.3.6 Recharging the Battery Pack for Model 911 .....	34
4.4 Wiring the RS232 Interface .....	35
4.4.1 RS232 Serial Port .....	35
4.5 Wiring the Sampler Interface on Model 940 .....	36
4.6 Sampler Receptacle (940 Only) .....	37
4.6.1 Connecting the Sampler Cable to a 940 Flow Meter .....	38
4.6.2 Connecting a Non-Sigma Sampler to a 940 Flow Meter .....	38
<b>Section 5 Software and Communications</b> .....	41
5.1 Required Software .....	41
5.2 Programming and Analysis Options .....	41
<b>Section 6 Sensor Installation</b> .....	43
6.1 Downlook Ultrasonic Sensor .....	43
6.1.1 Installing the Downlook Ultrasonic Sensor .....	43
6.1.2 Troubleshooting the Downlook Ultrasonic Sensor Installation .....	48
6.2 In-Pipe Ultrasonic Sensor .....	49
6.2.1 Mounting the In-Pipe Sensor .....	49
6.2.2 Angling the Beam .....	50
6.2.3 Calibrating the In-Pipe Ultrasonic Sensor .....	50
6.2.4 Protecting the In-Pipe Ultrasonic Sensor .....	51
6.2.5 Troubleshooting the In-Pipe Sensor .....	52
6.3 Installing the Submerged Area/Velocity Sensor .....	52
6.3.1 Zeroing the Submerged Area/Velocity Sensor .....	52
6.3.2 Important Installation Guidelines for Submerged Area/Velocity Sensor .....	52
6.3.3 Connecting the Submerged Area/Velocity Sensor to the Mounting Bands .....	53
6.3.4 Placing the Submerged Area/Velocity Sensor and the Mounting Band into the Pipe .....	54
<b>Section 7 Maintenance</b> .....	57
7.1 Maintaining the Battery Compartment Desiccant .....	57

## Table of Contents

---

7.1.1 Replacing the Battery Compartment Desiccant .....	57
7.2 Maintaining the O-Ring Gasket on the End Cap .....	57
7.3 Cleaning the Flow Meters .....	58
7.4 Storing the Flow Meters .....	58
7.5 Cleaning the Connectors .....	58
7.6 Maintaining the Electronics Compartment .....	58
7.6.1 Fuses .....	58
7.6.2 Memory Batteries .....	58
7.7 Replacing the Batteries in the RS232 Interface .....	59
7.8 Maintaining the Submerged Area/Velocity Sensor .....	59
7.8.1 Cleaning the Transducer Port .....	59
7.8.2 Cleaning the Submerged Area/Velocity Sensor (Oil-filled and Non-oil) .....	60
7.8.3 Replenishing the Oil .....	62
7.8.4 Changing the Submerged Area/Velocity Sensor Desiccant .....	63
7.8.5 Replacing the Desiccant .....	64
<b>Section 8 Replacement Parts and Accessories .....</b>	<b>67</b>
8.1 Flow Meter Replacement Parts .....	67
8.2 Sensors .....	67
8.3 Sensor Mounting Rings and Bands .....	67
8.4 Ultrasonic Sensor Mounting Hardware .....	68
8.5 Mounting Plate Hardware for Directly Mounting to Pipe Wall .....	69
<b>Section 9 Contact Information .....</b>	<b>71</b>
<b>Section 10 Contact information for Europe .....</b>	<b>72</b>
<b>Section 11 Limited Warranty .....</b>	<b>73</b>
<b>Appendix A Working with Primary Devices .....</b>	<b>75</b>
<b>Appendix B Channel Installation Options .....</b>	<b>81</b>
<b>Appendix C Batteries and Chargers .....</b>	<b>87</b>
<b>Appendix D SCADA-Modbus® System Guidelines .....</b>	<b>91</b>

# Section 1 Specifications

Specifications are subject to change without notice.

**Table 1 911 Flow Meter Specifications**

General	
<b>Certification</b>	cCSAus Approved for Class 1 and Division 1, and Group C
<b>Dimensions</b>	16.5 cm dia. x 57 cm L (6.5 in. x 22.5 in.) with 12 amp battery
<b>Weight</b>	8 kg (17.5 lb) with 12 amp hour battery pack
<b>Enclosure Material</b>	PVC
<b>Enclosure Rating</b>	NEMA, 6P (IP67)
<b>Operating Temperature</b>	-18 to 60 °C (0 to 140 °F)
<b>Storage Temperature</b>	-40 to 60 °C (-40 to 140 °F)
<b>Power Source</b>	12 amp hour battery pack
<b>Battery Life</b>	90 days typical with a 15 minute recording interval. Assumes data download once per week, at 10 °C (50 °F), also affected by site conditions.
<b>User Interface</b>	Optically Isolated Interface to IBM compatible PC
<b>Monitoring Intervals</b>	1, 2, 3, 5, 6, 10, 12, 15, 20, 30, and 60 minutes
<b>Program Memory</b>	Non-volatile, programmable flash, can be updated via RS232 port
<b>Time Based Accuracy</b>	±1 second per day
<b>Unit Measurements</b>	Level: in., m, cm, ft
	Flow: gps, gpm, lps, lpm, lph, mgd, afd, cfs, cfm, cfh, cfd, m <sup>3</sup> s, m <sup>3</sup> m, m <sup>3</sup> h, m <sup>3</sup> d
	Totalized Flow: gal, ft <sup>3</sup> , acre-ft, L, m <sup>3</sup>
<b>Data Storage</b>	Capacity: 400 days of 1 level reading and 1 velocity reading at a 15 minute recording interval. Data Types: Level and Velocity Storage Mode: Wrap or Slate
<b>Communications</b>	Serial connection via optically isolated interface to IBM compatible computer with Sigma analysis software.
Submerged Area/Velocity Sensor	
<b>Velocity Measurement</b>	Method: Doppler Ultrasound Twin 1 MHz piezoelectric crystals
	Typical Minimum Depth: 2 cm (0.8 in.)
	Zero Stability: 0.015 m/s (<0.05 ft/s)
	Accuracy: ± 2% of reading
	Recommended Range: -1.52 to 6.10 m/s (-5 to 20 ft/s)
<b>Depth Measurement</b>	Method: Pressure transducer with stainless steel diaphragm
	Accuracy (static) <sup>1</sup> : ±0.16% full scale ±1.5% of reading at constant temp (± 2.5 °C) ±0.20% full scale ±1.75% of reading from 0 to 30 °C (32 to 86 °F) ±0.25% full scale ±2.1% of reading from 0 to 70 °C (32 to 158 °F)
	Velocity-Induced Depth Error: Compensated based on pipe geometry and flow velocity.
	Depth Range: Standard: 0-3 m (0-10 ft); Extended: 0-9 m (0-30 ft)
Submerged Area/Velocity Sensor (continued)	
<b>Air Intake</b>	Atmospheric pressure reference is desiccant protected.
<b>Operating Temperature</b>	0 to 70 °C (32 to 158 °F)

## Specifications

**Table 1 911 Flow Meter Specifications (continued)**

<b>Depth Compensated Temperature</b>	0 to 70 °C (32 to 158 °F)
<b>Material</b>	Noryl® plastic outer shell with epoxy potting within
<b>Power Consumption</b>	≤1.2 W @ 12 VDC
<b>Cable Material</b>	Urethane sensor cable with air vent
<b>Cable Lengths Available</b>	Standard: 9, 15, 23, and 30.5 m (30, 50, 75, and 100 ft) Custom: 30.75-76 m (101-250 ft) maximum
<b>Cable Diameter</b>	0.91 cm (0.36 in.)
<b>Dimensions</b>	2.3 cm H x 3.8 cm W x 13.5 cm L (0.9 in. H x 1.5 in. W x 5.31 in. L)

<sup>1</sup> For temperatures above 40 °C (104 °F) add ± 0.3 cm/°C (0.03 in./°F)

**Table 2 940 Flow Meter Specifications**

General	
<b>Certification</b>	cCSAus Approved for Class 1 and Division 1
<b>Dimensions</b>	21.9 cm dia. x 60 cm L (8.625 in. x 18.25 in.)
<b>Weight</b>	8.16 kg (18 lb)
<b>Enclosure Material</b>	PVC
<b>Enclosure Rating</b>	NEMA 6P, IP 67
<b>Operating Temperature</b>	-18 to 60 °C (0 to 140 °F)
<b>Storage Temperature</b>	-40 to 60 °C (-40 to 140 °F)
<b>Power Source</b>	One (14 V) 16 amp hour lithium rechargeable battery pack
<b>Battery Life</b>	330 days typical with a 15 minute recording interval, 1 level and 1 velocity, data download once per week, 10 °C (50 °F) (also affected by site conditions)
<b>User Interface</b>	Optically Isolated Interface to IBM compatible PC
<b>Monitoring Intervals</b>	1, 2, 3, 5, 6, 10, 12, 15, 20, 30, and 60 minutes
<b>Program Memory</b>	Non-volatile, programmable flash, can be updated via RS232 port
<b>Time Based Accuracy</b>	±1 second per day
<b>Unit Measurements</b>	Level: in., m, cm, ft
	Flow: gps, gpm, lps, lpm, lph, mgd, afd, cfs, cfm, cfh, cfd, m <sup>3</sup> s, m <sup>3</sup> m, m <sup>3</sup> h, m <sup>3</sup> d
	Totalized Flow: gal, ft <sup>3</sup> , acre-ft, L, m <sup>3</sup>
<b>Data Storage</b>	Capacity: 306 days of 2 level readings and 2 velocity readings at a 15 minute recording interval. Data Types: Level and Velocity Storage Mode: Wrap or Slate
<b>Output Conditions</b>	Set point on level, velocity, flow, or flow rate of change.
<b>Sampler Output</b>	6-12 V dc pulse, 100 mA max at 500 ms duration with approved interface.
Communications	
<b>Connection</b>	Serial connection via optically isolated interface to IBM compatible computer with analysis software.
<b>Local Terminal</b>	RS232 at 19.2 k baud

Table 2 940 Flow Meter Specifications (continued)

Submerged Area/Velocity Sensor	
Velocity Measurement	Method: Doppler Ultrasound Twin 1 MHz piezoelectric crystals
	Typical Minimum Depth: 2 cm (0.8 in.)
	Zero Stability: 0.015 m/s (<0.05 ft/s)
	Accuracy: $\pm 2\%$ of reading <sup>1</sup>
	Recommended Range: $-1.52$ to $6.10$ m/s ( $-5$ to $20$ ft/s)
Depth Measurement	Method: Pressure transducer with stainless steel diaphragm
	Accuracy (static) <sup>2</sup> : $\pm 0.16\%$ full scale $\pm 1.5\%$ of reading at constant temp ( $\pm 2.5$ °C) $\pm 0.20\%$ full scale $\pm 1.75\%$ of reading from $0$ to $30$ °C ( $32$ to $86$ °F) $\pm 0.25\%$ full scale $\pm 2.1\%$ of reading from $0$ to $70$ °C ( $32$ to $158$ °F)
	Velocity-Induced Depth Error: Compensated based on pipe geometry and flow velocity.
	Depth Range: Standard: $0-3$ m ( $0-10$ ft); Extended: $0-9$ m ( $0-30$ ft)
Air Intake	Atmospheric pressure reference is desiccant protected.
Operating Temperature	$0$ to $70$ °C ( $32$ to $158$ °F)
Depth Compensated Temperature	$0$ to $70$ °C ( $32$ to $158$ °F)
Material	Noryl® plastic outer shell with epoxy potting within
Power Consumption	$\leq 1.2$ W @ 12 VDC
Cable Material	Urethane sensor cable with air vent
Cable Lengths Available	Standard: $9$ , $15$ , $23$ , and $30.5$ m ( $30$ , $50$ , $75$ , and $100$ ft)
Cable Diameter	$0.91$ cm ( $0.36$ in.)
Dimensions	$2.3$ cm H x $3.8$ cm W x $13.5$ cm L ( $0.9$ in. H x $1.5$ in. W x $5.31$ in. L)
In-Pipe Ultrasonic Sensor	
Operating Frequency	$75$ kHz
Accuracy	$\pm 0.027$ ft for sensor to liquid distance between $2.5$ inches and $5$ ft at $\pm 1$ ft change in head from calibration point, $20$ °C still air, ideal target, $25$ ft cable.
Range	Distance from sensor to liquid: $0.2$ inches (minimum) to $5$ feet (maximum), @ $20$ °C still air, ideal target, $25$ ft cable.
Resolution	$0.019$ cm ( $0.0075$ in.)
Operating Temperature Range	$-20$ to $60$ °C ( $-4$ to $140$ °F)
Storage Temperature	$-20$ to $60$ °C ( $-4$ to $140$ °F)
Temperature Error	$0.00005$ meter/°C typical
Material	Stat-Kon A-E ABS Plastic
Cable Length	$7.6$ m ( $25$ ft) standard, maximum custom length is $30.5$ m ( $100$ ft.)
Dimensions	$4.44$ cm ( $1.75$ in.) maximum diameter, $31.435$ cm ( $12.375$ in.) long
Mounting	Dedicated Mounting Rings, Permanent Mounting Bracket (installs directly to pipe wall), Adjustable Mounting Band Kit.

## Specifications

**Table 2 940 Flow Meter Specifications (continued)**

<b>Downlook Ultrasonic Sensor</b>	
<b>Operating Frequency</b>	75 kHz
<b>Beam Angle</b>	5°
<b>Accuracy</b>	±15.24 cm or 3.048 m ±0.003 m (±0.01 ft), at 22 °C (72 °F), still air, 40–70% relative humidity, from 6 in. to 10 ft
<b>Range</b>	10 ft
<b>Operating Temperature</b>	–18 to 60 °C (0 to 140 °F)
<b>Temperature Error</b>	0.00005 m/°C (0.0001 ft/°F) (maximum error with compensated temperature range—per degree of change.
<b>Resolution</b>	0.019 cm (0.0075 in.)
<b>Material</b>	ABS housing with ABS acoustical window
<b>Cable Length</b>	7.62 to 30.48 m (25 to 100 ft)
<b>Dimensions</b>	15.24 cm x 5.7 cm (6 in. x 2.25 in.)

<sup>1</sup> When the sensor is out of the water, the system may report velocity readings of up to 0.76 m/s due to radio frequency and interferences at frequencies of 140–170 MHz and 300 MHz with field strengths greater than 3 V/m.

<sup>2</sup> For temperatures above 40 °C (104 °F) add ± 0.3 cm/°C (0.03 in./°F)



# Section 2 General Information

## 2.1 Safety Information

Read the entire manual before unpacking, setting up, or operating this instrument. Pay particular attention to all danger and caution statements. Failure to do so could result in serious injury to the operator or damage to the equipment.

To ensure that the protection provided by this equipment is not impaired, do not use or install this equipment in any manner other than what is specified in this manual.

### 2.1.1 Use of Hazard Information

#### **DANGER**

*Indicates a potentially or imminently hazardous situation which, if not avoided, could result in death or serious injury.*

#### **CAUTION**





*Indicates a potentially hazardous situation that may result in minor or moderate injury.*

*Important Note: Information that requires special emphasis.*

*Note: Information that supplements points in the main text.*

### 2.1.2 Precautionary Labels

Read all labels and tags attached to the instrument. Personal injury or damage to the instrument could occur if not observed. A symbol, if noted on the instrument, will be included with a danger or caution statement in the manual.

	This symbol, if noted on the instrument, references the instruction manual for operation and/or safety information.
	Electrical equipment marked with this symbol may not be disposed off in European public disposal systems after 12 August of 2005. In conformity with European local and national regulations (EU Directive 2002/96/EC), European electrical equipment users must now return old or end-of life equipment to the <i>producer</i> for disposal at no charge to the user. <b>Note:</b> For return for recycling, please contact the equipment producer or supplier for instructions on how to return end-of-life equipment, producer-supplied electrical accessories, and all auxiliary items for proper disposal.
	This symbol, when noted on a product enclosure or barrier, indicates that a risk of electrical shock and/or electrocution exists and indicates that only individuals qualified to work with hazardous voltages should open the enclosure or remove the barrier.
	This symbol, when noted on the product, identifies the location of a fuse or current limiting device.
	This symbol, when noted on the product, indicates that the marked item can be hot and should not be touched without care.
	This symbol, when noted on the product, indicates the presence of devices sensitive to Electro-static Discharge and indicates that care must be taken to prevent damage to them.
	This symbol, if noted on the product, indicates the need for protective eye wear.
	This symbol, when noted on the product, identifies the location of the connection for Protective Earth (ground).

### 2.1.3 Hazardous Locations

**DANGER**

*Although some Sigma products are designed and certified for installation in hazardous locations as defined by the National Electrical Code, many Sigma products are not suitable for use in hazardous locations. It is the responsibility of the individuals who are installing the products in hazardous locations to determine the acceptability of the product for the environment. Additionally, to ensure safety, the installation of instrumentation in hazardous locations must be as per the manufacturer's control drawing specifications. Any modification to the instrumentation or the installation is not recommended and may result in life threatening injury and/or damage to facilities.*

**DANGER**

*Bien que certains produits Sigma soient conçus et certifiés pour être installés dans des endroits dangereux tels que définis par le National Electric Code, de nombreux produits Sigma ne conviennent pas pour de tels endroits. Il relève de la responsabilité des personnes qui placent les produits dans des endroits dangereux de déterminer s'ils sont adaptés à cet environnement. En outre, à des fins de sécurité, le placement de machines dans des endroits dangereux doit s'effectuer dans le respect des consignes des schémas de contrôle du fabricant. Toute modification apportée aux machines ou tout déplacement de celles-ci est déconseillé, car susceptible de provoquer des accidents matériels et/ou corporels.*

### 2.1.4 Intrinsically Safe Equipment

The 911 and 940 Flow Meters are listed as “Intrinsically Safe” for Class 1, Div.1, Groups C, and D Hazardous Locations. This means that the circuits within these flow meters are designed to be incapable of producing a spark or thermal effect that could ignite a mixture of flammable or combustible gases when properly installed in a Class 1, Division 1, Group C, or Group D Hazardous Location. It does not mean that these flow meters are “Explosion Proof”. If proper safety precautions are not followed, or if the equipment is not installed properly, there is a serious potential for explosion. Be sure to review all safety precautions, installation, and wiring practices throughout this manual prior to installing a 911 or 940 Flow Meter.

#### 2.1.4.1 Intrinsically Safe Installation Requirements

- It is important that the installer of an Intrinsically Safe system reference the requirements of the authority having jurisdiction at the installation site. In the United States, reference should be made to Article 504 of the National Electric Code and ANSI/ISA RP 12.6. The 911 and 940 Flow Meters should be installed in accordance to these requirements and in accordance with the approved control drawings in the manual (Refer to [section 4.1 on page 15](#)).
- Wherever possible, associated apparatus should be mounted in a non-hazardous location, closest to the hazardous location. This minimizes the length of the intrinsically safe conductors within the non-hazardous location, thereby decreasing the possibility of inadvertent connection to non-intrinsically safe energy to the protected circuit. It is recommended that the associated apparatus be mounted and installed in dust and moisture free enclosures. Dust and moisture are conductive materials and may compromise the required minimum distance of 50 mm (2 in.) between intrinsically safe and non-intrinsically safe conductors. The panel layout of these enclosures should be constructed such that the separation of intrinsically safe and non-intrinsically safe conductors is maximized.

### 2.1.4.2 Intrinsically Safe Wiring Practices

**DANGER**

*Intrinsically safe wiring must be separated from non-intrinsically safe wiring to prevent the transferring of unsafe levels of energy to the hazardous area.*

**DANGER**

*Le câblage à sécurité intrinsèque doit être séparé du câblage à sécurité non intrinsèque afin d'empêcher tout transfert de niveaux d'énergie non sûrs vers la zone dangereuse.*

The following practices are meant to be used as guidelines or recommendations only. For specific rules or more detailed practices, refer to the National Electric Code, Canadian Electric Code, or ANSI/ISA-RP 12.6-1987 or subsequent.

Intrinsically safe wiring must be installed, maintained, and repaired with considerations for the following:

**Connections**

Do not connect non-intrinsically safe wiring to intrinsically safe terminations of any associated apparatus, usually identified with light blue.

**Routing**

Intrinsically safe wiring must enter or leave the non-hazardous location by the shortest and most direct route.

**Clearances**

A clearance distance of at least 50 mm (2 in.) must be maintained between any non-intrinsically safe conductors and intrinsically safe wiring or terminations.

The only exceptions allowed for minimum clearances are:

- All intrinsically safe circuit conductors are in Type MI or MC cables or
- All non-intrinsically safe circuit conductors are in raceways or Type MI or MC cables where the sheathing or cladding is capable of carrying fault current to the ground.

**Raceways**

Raceways should be used to keep intrinsically safe wire and non-intrinsically safe wire separated. Wire lacing or ties are considered acceptable methods. All raceways for the intrinsically safe system are identified with permanently affixed labels with the wording Intrinsic Safety Wiring or equivalent.

**Conductor Identification**

Intrinsically safe conductors must be identified, either by color coding with light blue jacketed cable or by tagging, at regular intervals of every 7.62 m (25 ft), as identified by NEC (National Electric Code).

**Voltage Limitations**

The electrical equipment for non-hazardous location must not contain a source voltage greater than 250 V unless sufficient means have been employed to prevent the shorting of a source voltage greater than 250 V onto the non-intrinsically safe terminals of the associated apparatus.

### **Multi-Conductor Cable**

Conductors may be part of a multi-conductor cable provided that all conductors within the cable are intrinsically safe. Each intrinsically safe conductor must have an insulation thickness of 0.25 mm (0.010 in.) which is rated for the maximum temperature rating of the approved device to which it is connected. The intrinsically safe wiring must be color coded with light blue, if no other wiring is light blue or appropriately tagged.

### **Seals**

A seal must be provided at the point the intrinsically safe wire passes between the hazardous and non-hazardous locations to prevent the hazardous atmosphere from entering the unprotected control room environment. The seal specification is that it must not pass more than 198 cm<sup>3</sup> (0.007 ft<sup>3</sup>) of air per hour at a pressure equivalent to 6 in. (1493 Pa) of water. While this is the same specification for the sealing requirements of an explosion proof system, it may not be necessary to employ those seals.

### **Grounding**

The 911 and 940 Flow Meters and associated Opto-Isolated Interfaces do not require grounding or bonding. Under no circumstances should any attempt be made to ground or bond the 911 or 940 Flow Meters or Opto-Isolated Interfaces.

## **2.1.5 Confined Space Entry**

***Important Note:** The following information is provided to guide users of 911 and 940 Flow Meters on the dangers and risks associated with entry into confined spaces.*

### **DANGER**

***Additional training in Pre-Entry Testing, Ventilation, Entry Procedures, Evacuation/Rescue Procedures and Safety Work Practices is necessary to ensure against the loss of life in confined spaces.***

### **DANGER**

***Pour éviter les accidents mortels dans les espaces confinés, il faut organiser des formations supplémentaires dans les matières suivantes: Contrôle avant entrée, Ventilation, Procédures d'entrée, Procédures d'évacuation et de secours et Méthodes de travail sûres.***

On April 15, 1993, OSHA's final ruling on CFR 1910.146, Permit Required Confined Spaces, became law. This standard directly affects more than 250,000 industrial sites in the United States and was created to protect the health and safety of workers in confined spaces.

### **2.1.5.1 Definition of Confined Space**

Confined Space is any location or enclosure that presents or has the immediate potential to present one or more of the following conditions:

- An atmosphere with less than 19.5% or greater than 23.5% oxygen and/or more than 10 ppm Hydrogen Sulfide (H<sub>2</sub>S)
- An atmosphere that may be flammable or explosive due to gases, vapors, mist, dust, or fibers
- Toxic materials which, upon contact or inhalation, could result in injury, impairment of health, or death

Confined spaces are not designed for human occupancy. They have restricted entry and contain known or potential hazards.

Examples of confined spaces include manholes, stacks, pipes, vats, switch vaults, and other similar locations.

**Important Note:** *Standard safety procedures must always be followed prior to entry into confined spaces and/or locations where hazardous gases, vapors, mist, dust, or fibers may be present.*

**Note:** *Before entering any confined space, check with the employer for procedures related to confined space entry.*



## Section 3 Getting Started

---

### 3.1 Installing the Flow Meter-Considerations

#### 3.1.1 Choosing the Proper Site

The accuracy of flow measurement depends on the suitability of individual monitoring sites. Select sites that have normalized flow and minimal turbulence. Turbulence can make it difficult to detect an average velocity in the flow stream. Obstructions, vertical drops, pipe bends, and elbows can create turbulence. [Table 3](#) contains suggestions for preventing turbulence.

**Table 3 Suggestions for Preventing Turbulence**

Site Condition	Suggested Remedy
Outfalls	Attach the sensor at least ten times the maximum expected level upstream of the outfall.
Vertical drops in the channel floor	Attach the sensor at least ten times the maximum expected level upstream of the vertical drop.
	Attach the sensor at least ten times the maximum expected level downstream of the vertical drop.
Elbows, sharp turns, and “Y” connections	Locate the sensor at least ten times the maximum expected level upstream of the obstruction.
	Locate the sensor at least ten times the maximum expected level downstream of the obstruction.

#### 3.1.2 Dealing with Difficult Sites

Some sites may be difficult to monitor due to poor site conditions. The direction and speed of particles in the flow stream contribute to the signal received by the velocity sensor. If the turbulence near the measurement point is excessive, it may be difficult for the sensor to determine the average velocity of the stream. The flow meters provide several unique features to help deal with these problem sites.

#### 3.1.3 Choosing the Appropriate Meter and Sensor Combination

Use [Table 4](#) to determine which sensor to use. See [Section 6 on page 43](#) for sensor installation instructions.

**Table 4 Flow Meter and Sensor Configurations**

Flow Meter Model	Level and Velocity Sensor Configurations
911	Meter plus one Submerged Area/Velocity Sensor or one Velocity-Only Sensor
940	Meter plus two Submerged Area/Velocity Sensors or Meter plus one Submerged Area/Velocity Sensor and one In-Pipe/Downlook Ultrasonic Sensor.





## Section 4 Meter Installation

---

**DANGER**

***Only qualified personnel should conduct the tasks described in this section of the manual.***

**DANGER**

***Seul un technicien qualifié peut effectuer les tâches d'installation décrites dans cette section du manuel.***

This section describes the **ONLY** approved installation instructions for the 911 and 940 Flow Meters. This section also describes battery installation and interface wiring for a RS232, Modem, and Sampler connection.

### 4.1 Approved 911 and 940 Installation Drawings

**DANGER**

***Any installation or flow meter configuration not specifically detailed on the following control drawings is not allowed. In all cases, the local authority having jurisdiction shall have a final say.***

**DANGER**

***Il est interdit de procéder à toute installation ou configuration d'un débitmètre qui n'est pas explicitement détaillée dans les schémas de contrôle de l'installation ci-dessous. Dans tous les cas, c'est l'autorité locale responsable qui aura le dernier mot.***

Figure 1 on page 16 through Figure 13 on page 28 are approved control drawings. These certified drawings detail the **ONLY** approved method of installing the 911 and 940 Flow Meters. Additionally, these drawings list both part number, description, and the only certified sensors, probes, and associated equipment to be used with these meters. Any substitutions automatically void the Intrinsically Safe certification of the flow meter and could result in fire or explosion.

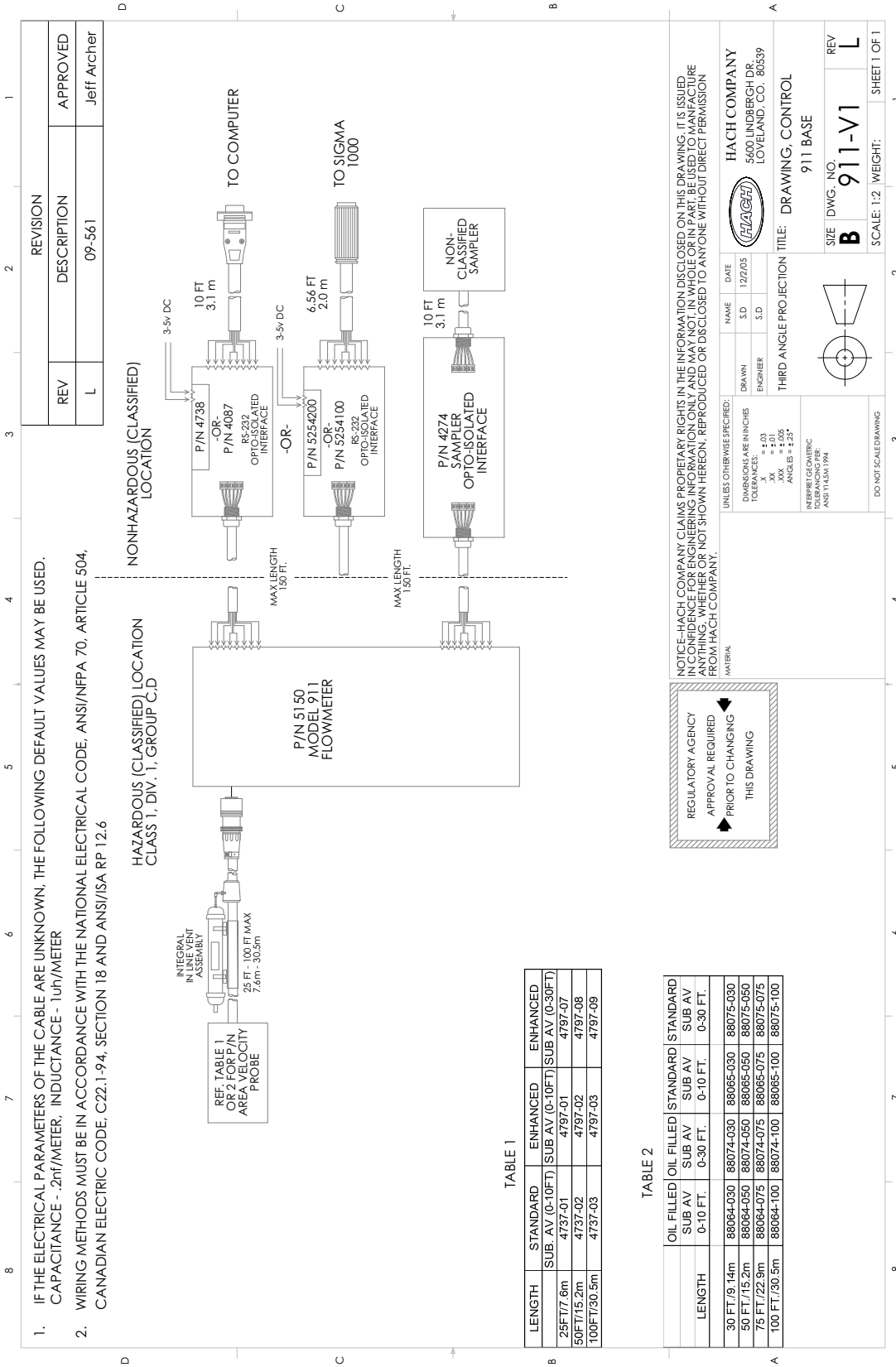

1. IF THE ELECTRICAL PARAMETERS OF THE CABLE ARE UNKNOWN, THE FOLLOWING DEFAULT VALUES MAY BE USED.  
CAPACITANCE - .2nF/METER, INDUCTANCE - 1uH/METER
2. WIRING METHODS MUST BE IN ACCORDANCE WITH THE NATIONAL ELECTRICAL CODE, ANSI/NFPA 70, ARTICLE 504, CANADIAN ELECTRIC CODE, C22.1-94, SECTION 18 AND ANSI/ISA RP 12.6

TABLE 1

LENGTH	STANDARD	ENHANCED	ENHANCED
	SUB. AV (0-10FT)	SUB AV (0-10FT)	SUB AV (0-30FT)
25FT/7.6m	4737-01	4797-01	4797-07
50FT/15.2m	4737-02	4797-02	4797-08
100FT/30.5m	4737-03	4797-03	4797-09

TABLE 2

LENGTH	OIL FILLED		STANDARD	
	SUB AV	SUB AV	SUB AV	SUB AV
30 FT./9.14m	88064-030	88074-030	88065-030	88075-030
50 FT./15.2m	88064-050	88074-050	88065-050	88075-050
75 FT./22.9m	88064-075	88074-075	88065-075	88075-075
100 FT./30.5m	88064-100	88074-100	88065-100	88075-100

REGULATORY AGENCY  
 APPROVAL REQUIRED  
 PRIOR TO CHANGING  
 THIS DRAWING

NOTICE-HACH COMPANY CLAIMS PROPRIETARY RIGHTS IN THE INFORMATION DISCLOSED ON THIS DRAWING. IT IS ISSUED IN CONFIDENCE FOR ENGINEERING INFORMATION ONLY AND MAY NOT IN WHOLE OR IN PART, BE USED TO MANUFACTURE ANYTHING, WHETHER OR NOT SHOWN HEREON, REPRODUCED OR DISCLOSED TO ANYONE WITHOUT DIRECT PERMISSION FROM HACH COMPANY.

UNLESS OTHERWISE SPECIFIED:  
 DIMENSIONS ARE IN INCHES  
 TOLERANCES:  
 .XX = ±.01  
 .XXX = ±.005  
 ANGLES = ±.5°

INTERPRET GEOMETRIC TOLERANCING PER ANSI Y14.5M 1994

DO NOT SCALE DRAWING

THIRD ANGLE PROJECTION TITLE: DRAWING: CONTROL

HACH COMPANY  
 5400 LINDBERGH DR.  
 LOVELAND, CO. 80539

DATE: 12/2/05  
 DRAWN: S.D.  
 ENGINEER: S.D.

911 BASE

SIZE: DWG. NO. **B 911-V1** REV **L**

SCALE: 1:2 WEIGHT: SHEET 1 OF 1

Figure 1 Control Drawing 911-V1

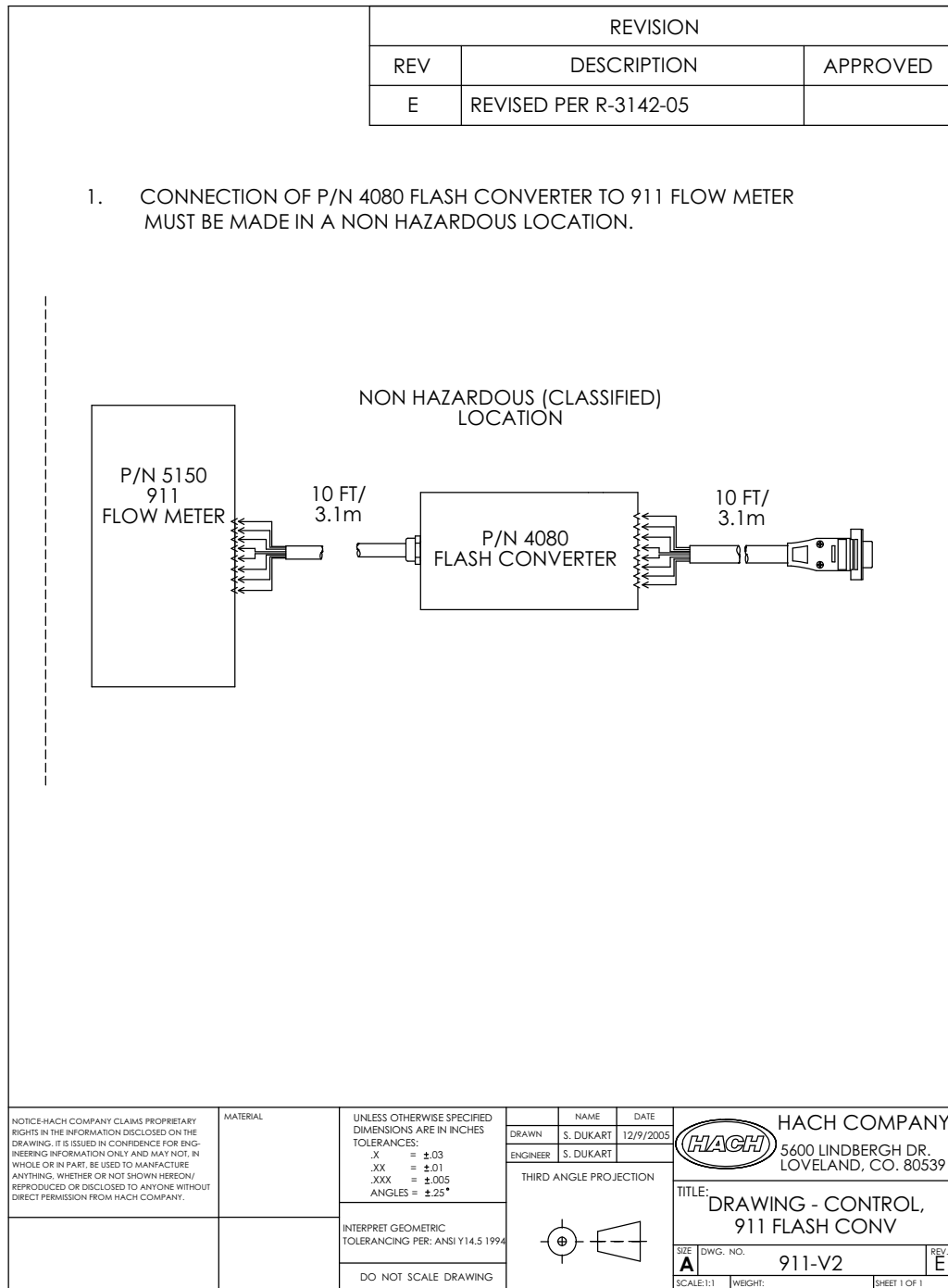
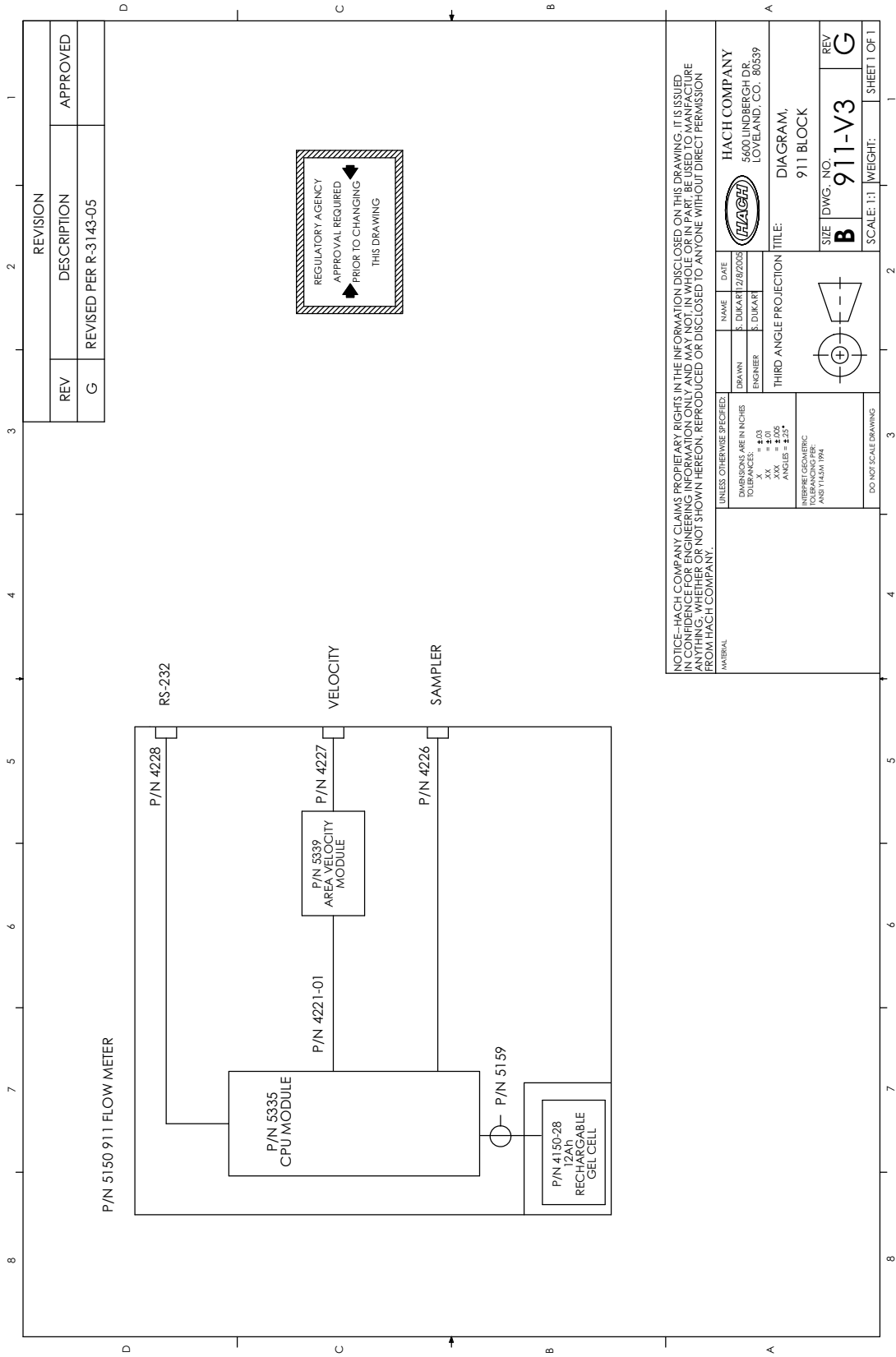

Figure 2 Control Drawing 911-V2



REVISION	
REV	DESCRIPTION
G	REVISED PER R-3143-05
APPROVED	

REGULATORY AGENCY  
 APPROVAL REQUIRED  
 PRIOR TO CHANGING  
 THIS DRAWING

NOTICE—HACH COMPANY CLAIMS PROPRIETARY RIGHTS IN THE INFORMATION DISCLOSED ON THIS DRAWING. IT IS ISSUED IN CONFIDENCE FOR ENGINEERING INFORMATION ONLY AND MAY NOT, IN WHOLE OR IN PART, BE USED TO MANUFACTURE ANYTHING, WHETHER OR NOT SHOWN HEREON, REPRODUCED OR DISCLOSED TO ANYONE WITHOUT DIRECT PERMISSION FROM HACH COMPANY.

UNLESS OTHERWISE SPECIFIED:	
DIMENSIONS ARE IN INCHES	DATE: 12/8/2008
TOLERANCES:	DRAWN: E. DIKART
XX = ±.01	ENGINEER: E. DIKART
XXX = ±.005	THIRD ANGLE PROJECTION
ANGLES = ±.25	INTERPRET GEOMETRIC CONSTRUCTION: AS PER ASME Y14.5M, 1994
DO NOT SCALE DRAWING	

HACH COMPANY  
 5400 LINDBERGH DR.  
 LOVELAND, CO. 80539

DIA. GRAM,  
 911 BLOCK

SIZE DWG. NO. **B 911-V3** REV **G**

SCALE: 1:1 WEIGHT: SHEET 1 OF 1

Figure 3 Control Drawing 911-V3

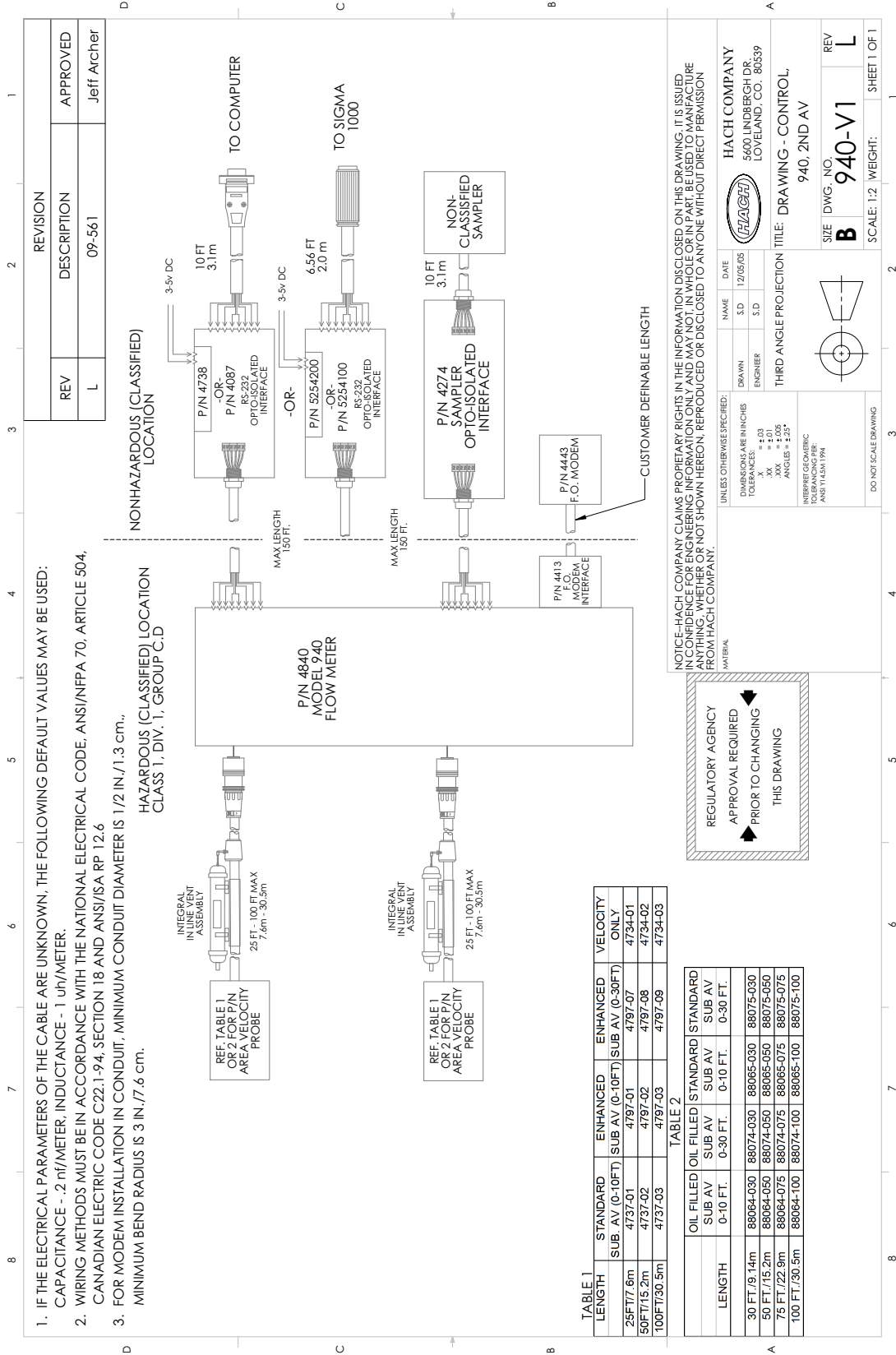
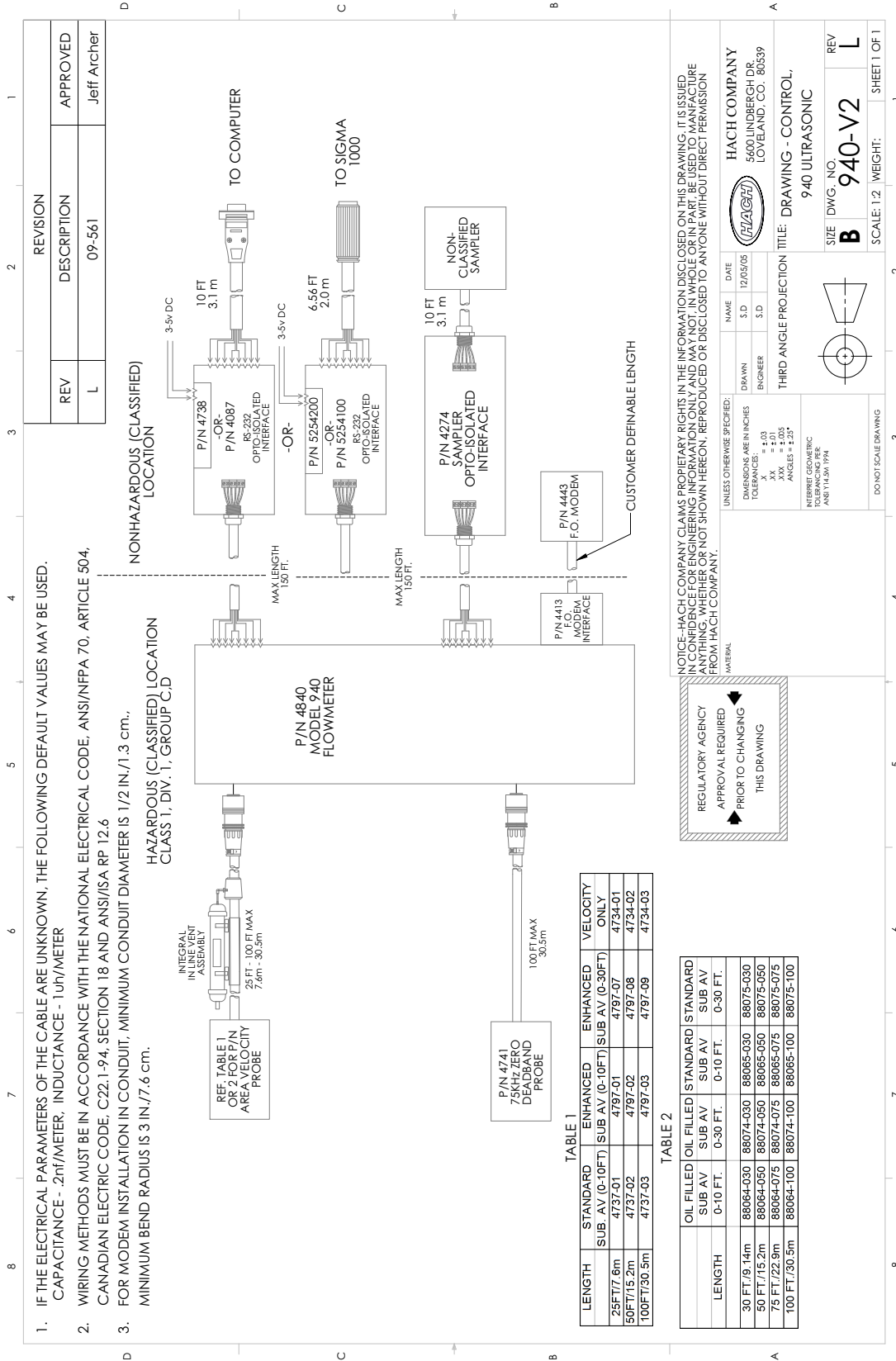

Figure 4 Control Drawing 940-V1



REV	DESCRIPTION	REVISION
L	09-561	APPROVED
		Jeff Archer

- IF THE ELECTRICAL PARAMETERS OF THE CABLE ARE UNKNOWN, THE FOLLOWING DEFAULT VALUES MAY BE USED.  
CAPACITANCE - .2nF/METER; INDUCTANCE - 1uH/METER
- WIRING METHODS MUST BE IN ACCORDANCE WITH THE NATIONAL ELECTRICAL CODE, ANSI/NFPA 70, ARTICLE 504, CANADIAN ELECTRIC CODE, C22.1-94, SECTION 18 AND ANSI/ISA RP 12.6
- FOR MODEM INSTALLATION IN CONDUIT, MINIMUM CONDUIT DIAMETER IS 1/2 IN./1.3 cm., MINIMUM BEND RADIUS IS 3 IN./7.6 cm.

HAZARDOUS (CLASSIFIED) LOCATION

NONHAZARDOUS (CLASSIFIED) LOCATION

REF. TABLE 1 OR 2 FOR P/N AREA VELOCITY PROBE

INTEGRAL IN LINE VENT ASSEMBLY  
25 FT - 100 FT MAX  
7.6m - 30.5m

P/N 4741 75KHz DEADBAND PROBE  
100 FT MAX  
30.5m

TABLE 1

LENGTH	STANDARD SUB. AV. (0-10FT)	ENHANCED SUB. AV. (0-10FT)	ENHANCED SUB. AV. (0-30FT)	VELOCITY ONLY
25FT/7.6m	4737-01	4797-01	4797-07	4734-01
50FT/15.2m	4737-02	4797-02	4797-08	4734-02
100FT/30.5m	4737-03	4797-03	4797-09	4734-03

TABLE 2

LENGTH	OIL FILLED SUB AV. (0-10 FT.)	FILLED SUB AV. (0-30 FT.)	STANDARD SUB AV. (0-10 FT.)	STANDARD SUB AV. (0-30 FT.)
30 FT./9.14m	88064-030	88074-030	88065-030	88075-030
50 FT./15.2m	88064-050	88074-050	88065-050	88075-050
75 FT./22.9m	88064-075	88074-075	88065-075	88075-075
100 FT./30.5m	88064-100	88074-100	88065-100	88075-100

UNLESS OTHERWISE SPECIFIED:  
DIMENSIONS ARE IN INCHES  
TOLERANCES:  
XX = ±.01  
XXX = ±.003  
FRACTIONS = 1/32

INTERPRET GEOMETRIC TOLERANCING PER ANSI Y14.5M 1994

DO NOT SCALE DRAWING

THIRD ANGLE PROJECTION TITLE: DRAWING - CONTROL, 940 ULTRASONIC

NAME DATE  
S.D. 12/05/05  
ENGINEER S.D.

DRAWN S.D.  
ENGINEER S.D.

HACH COMPANY  
5400 LINDBERGH DR  
LOVELAND, CO. 80539

SIZE DWG. NO. REV  
**B** 940-V2 **L**

SCALE: 1:2 WEIGHT: SHEET 1 OF 1

REGULATORY AGENCY APPROVAL REQUIRED PRIOR TO CHANGING THIS DRAWING

NOTICE-HACH COMPANY CLAIMS PROPRIETARY RIGHTS IN THE INFORMATION DISCLOSED ON THIS DRAWING. IT IS ISSUED IN CONFIDENCE FOR ENGINEERING INFORMATION ONLY AND MAY NOT BE USED IN WHOLE OR IN PART, BE USED TO MANUFACTURE ANYTHING, WHETHER OR NOT SHOWN HEREON, REPRODUCED OR DISCLOSED TO ANYONE WITHOUT DIRECT PERMISSION FROM HACH COMPANY.

Figure 5 Control Drawing 940-V2

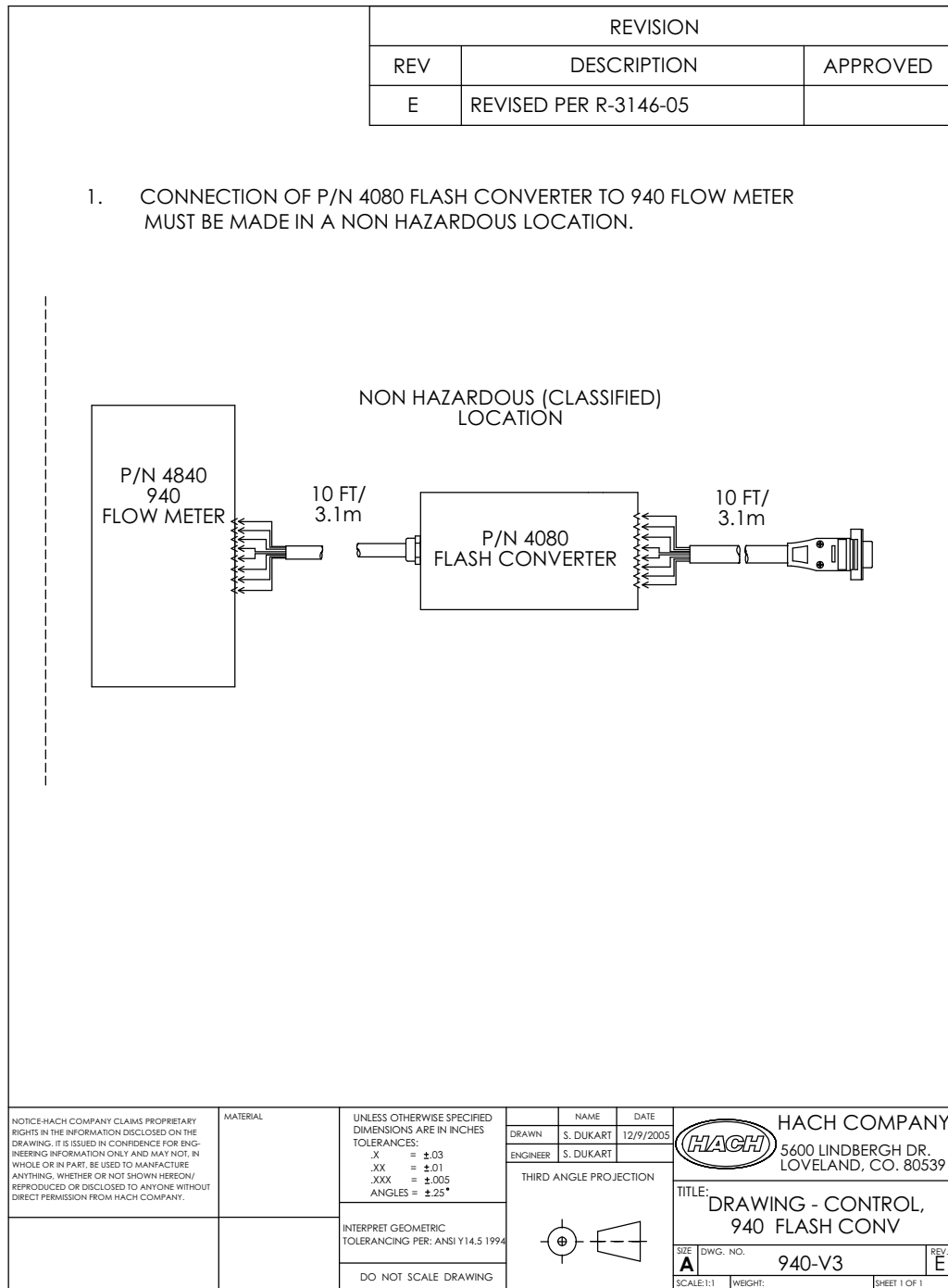
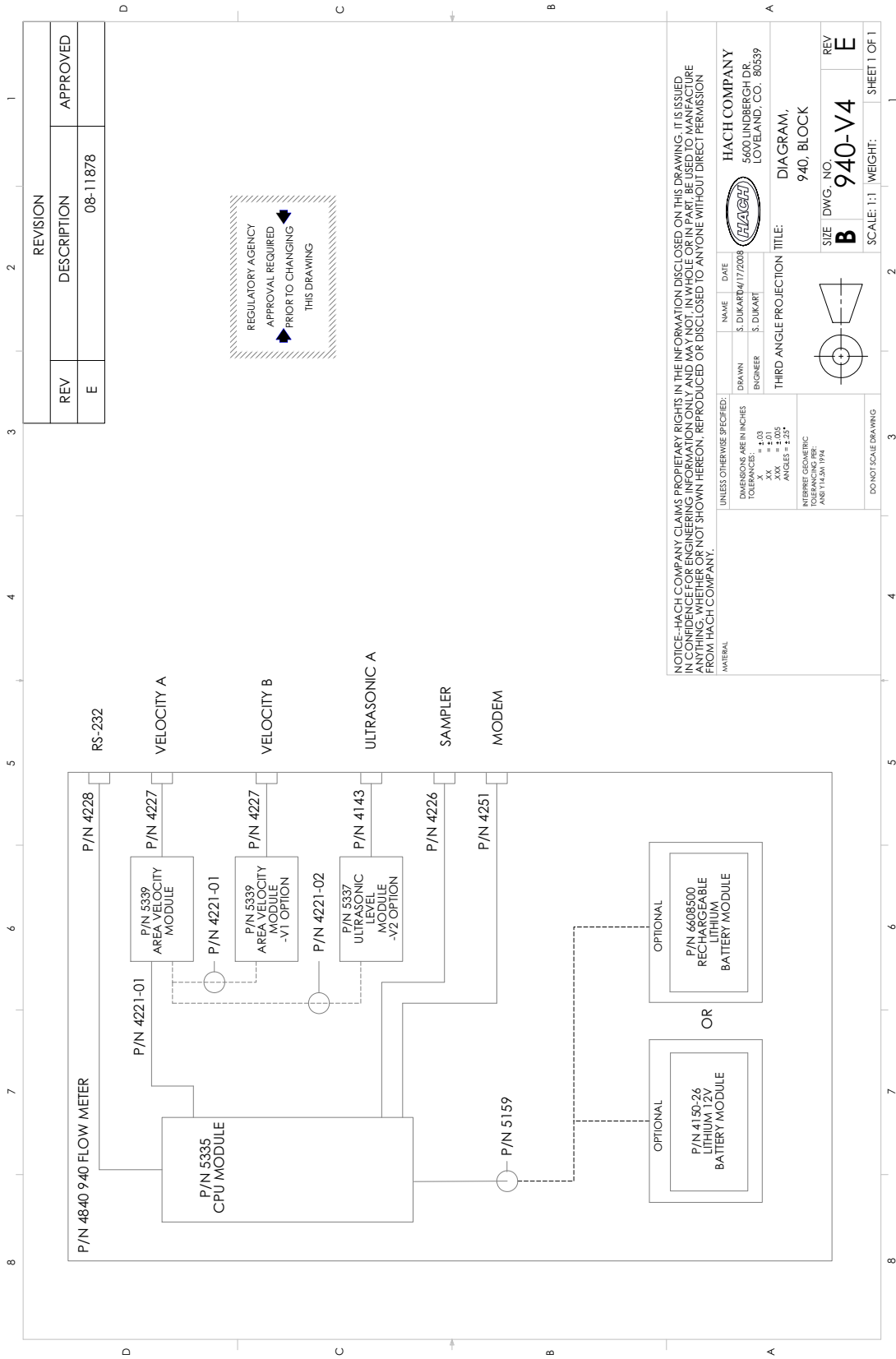

Figure 6 Control Drawing 940-V3



REVISION	
REV	DESCRIPTION
E	08-11878
APPROVED	

UNLESS OTHERWISE SPECIFIED:  
 DIMENSIONS ARE IN INCHES  
 TOLERANCES:  
 XX = ±.01  
 XXX = ±.005  
 ANGLES = ±.25°  
 INTERPRET GEOMETRIC TOLERANCING PER: ASME Y14.5-2009

DO NOT SCALE DRAWING

THIRD ANGLE PROJECTION TITLE: 940, BLOCK

NAME: S. DIKART  
 DATE: 5/17/2008  
 DRAWN: S. DIKART  
 ENGINEER: S. DIKART

HACH COMPANY  
 5400 LINDBERGH DR.  
 LOVELAND, CO. 80539

NOTICE—HACH COMPANY CLAIMS PROPRIETARY RIGHTS IN THE INFORMATION DISCLOSED ON THIS DRAWING. IT IS ISSUED IN CONFIDENCE FOR ENGINEERING INFORMATION ONLY AND MAY NOT, IN WHOLE OR IN PART, BE USED TO MANUFACTURE ANYTHING, WHETHER OR NOT SHOWN HEREON, REPRODUCED OR DISCLOSED TO ANYONE WITHOUT DIRECT PERMISSION FROM HACH COMPANY.

SIZE: DWG. NO. **B** 940-V4 REV **E**  
 SCALE: 1:1 WEIGHT: SHEET 1 OF 1

Figure 7 Control Drawing 940-V4



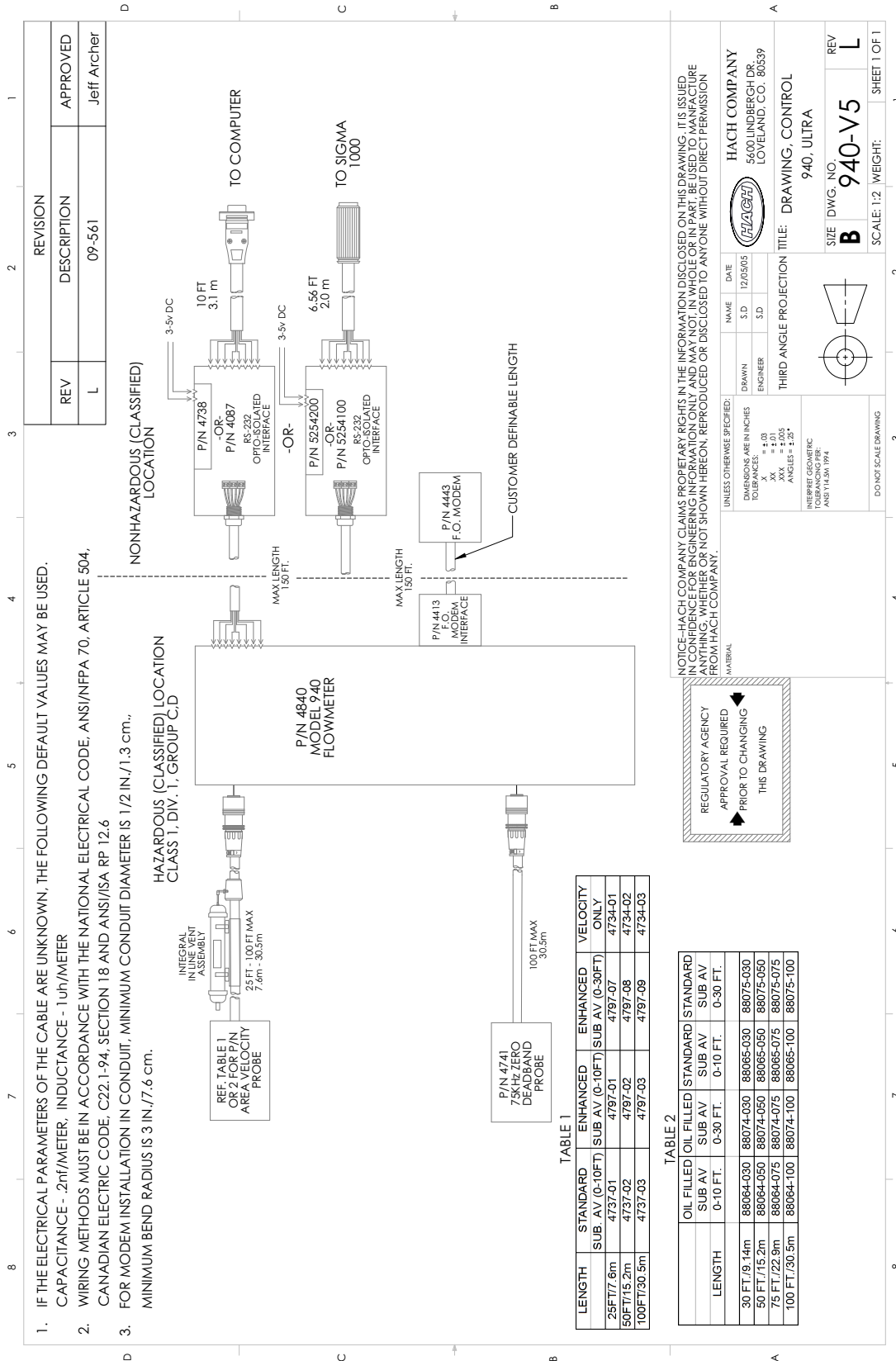
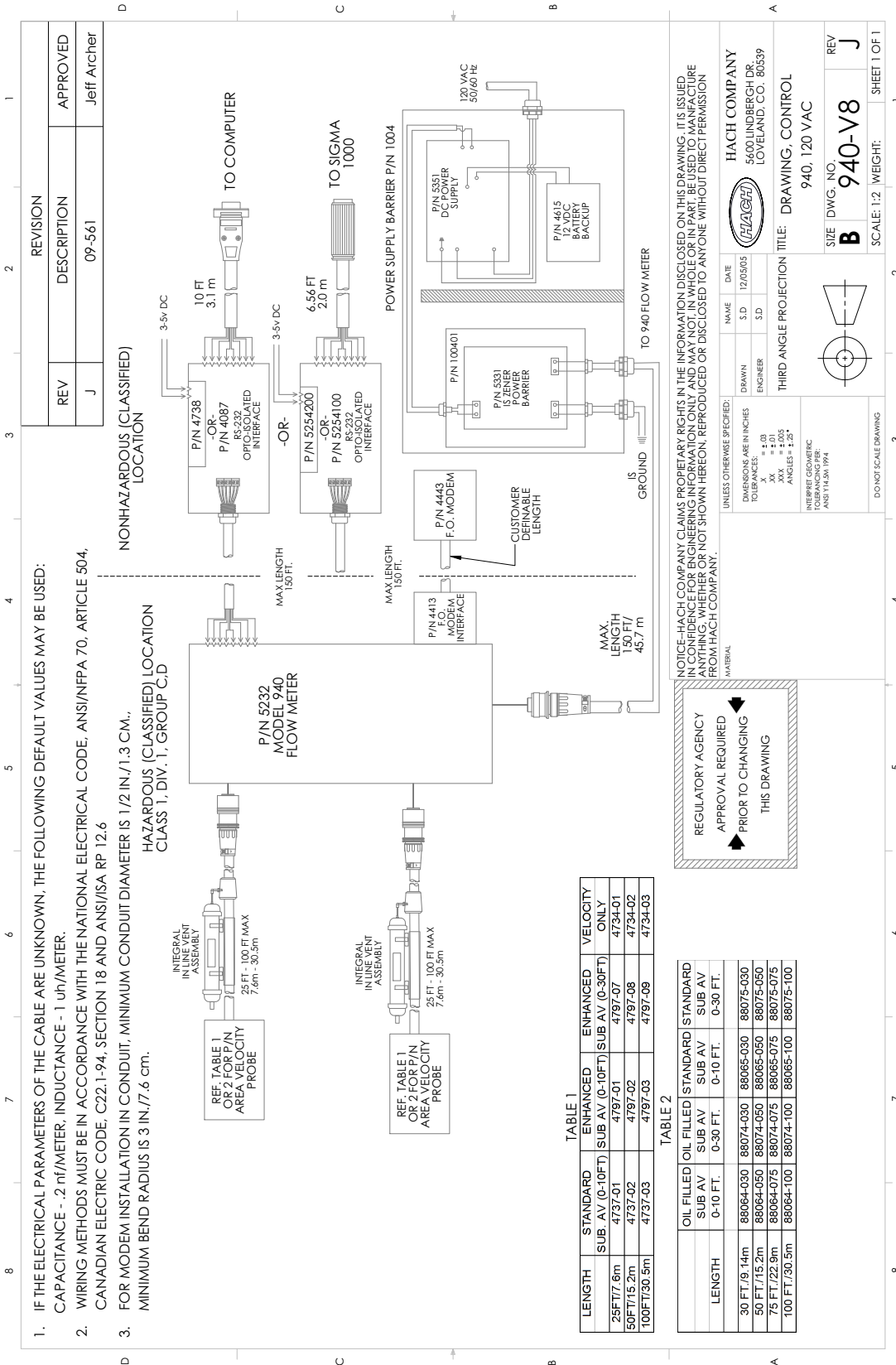

Figure 8 Control Drawing 940-V5



REV	DESCRIPTION	APPROVED
J	09-561	Jeff Archer

- IF THE ELECTRICAL PARAMETERS OF THE CABLE ARE UNKNOWN, THE FOLLOWING DEFAULT VALUES MAY BE USED:  
CAPACITANCE - 2 nF/METER, INDUCTANCE - 1 uH/METER.
- WIRING METHODS MUST BE IN ACCORDANCE WITH THE NATIONAL ELECTRICAL CODE, ANSI/NFPA 70, ARTICLE 504, CANADIAN ELECTRIC CODE, C22.1-94, SECTION 18 AND ANSI/ISA RP 12.6
- FOR MODEM INSTALLATION IN CONDUIT, MINIMUM CONDUIT DIAMETER IS 1/2 IN./1.3 CM., MINIMUM BEND RADIUS IS 3 IN./7.6 CM.

NONHAZARDOUS (CLASSIFIED) LOCATION

HAZARDOUS (CLASSIFIED) LOCATION CLASS 1, DIV. 1, GROUP C,D

TABLE 1

LENGTH	STANDARD SUB. AV (0-10FT)	ENHANCED SUB AV (0-10FT)	ENHANCED SUB AV (0-30FT)	VELOCITY ONLY
25 FT/7.6m	4737-01	4797-01	4797-07	4734-01
50 FT/15.2m	4737-02	4797-02	4797-08	4734-02
100 FT/30.5m	4737-03	4797-03	4797-09	4734-03

TABLE 2

LENGTH	OIL FILLED SUB AV (0-10 FT)	STANDARD SUB AV (0-10 FT)	STANDARD SUB AV (0-30 FT)
30 FT/9.14m	88064-030	88065-030	88075-030
50 FT/15.2m	88064-050	88065-050	88075-050
75 FT/22.9m	88064-075	88065-075	88075-075
100 FT/30.5m	88064-100	88065-100	88075-100

UNLESS OTHERWISE SPECIFIED:  
DIMENSIONS ARE IN INCHES  
TOLERANCES:  
XX = ±.01  
XXX = ±.005  
ANGLES = 1:25

INTERPRET GEOMETRIC SYMBOLS PER ANSI Y14.5M 1994

DO NOT SCALE DRAWING

REGULATORY AGENCY APPROVAL REQUIRED PRIOR TO CHANGING THIS DRAWING

THIRD ANGLE PROJECTION TITLE: DRAWING, CONTROL

940, 120 VAC

SCALE: 1:2 WEIGHT: SHEET 1 OF 1

SIZE DWG. NO. REV  
**B** 940-V8 **J**

HACH COMPANY  
5400 LINDBERGH DR  
LOVELAND, CO. 80539

NAME DATE  
S.D. 12/05/05  
ENGINEER S.D.

NOTICE-HACH COMPANY CLAIMS PROPRIETARY RIGHTS IN THE INFORMATION DISCLOSED ON THIS DRAWING. IT IS ISSUED IN CONFIDENCE FOR ENGINEERING INFORMATION ONLY AND MAY NOT IN WHOLE OR IN PART, BE USED TO MANUFACTURE ANYTHING, WHETHER OR NOT SHOWN HEREON, REPRODUCED OR DISCLOSED TO ANYONE WITHOUT DIRECT PERMISSION FROM HACH COMPANY.

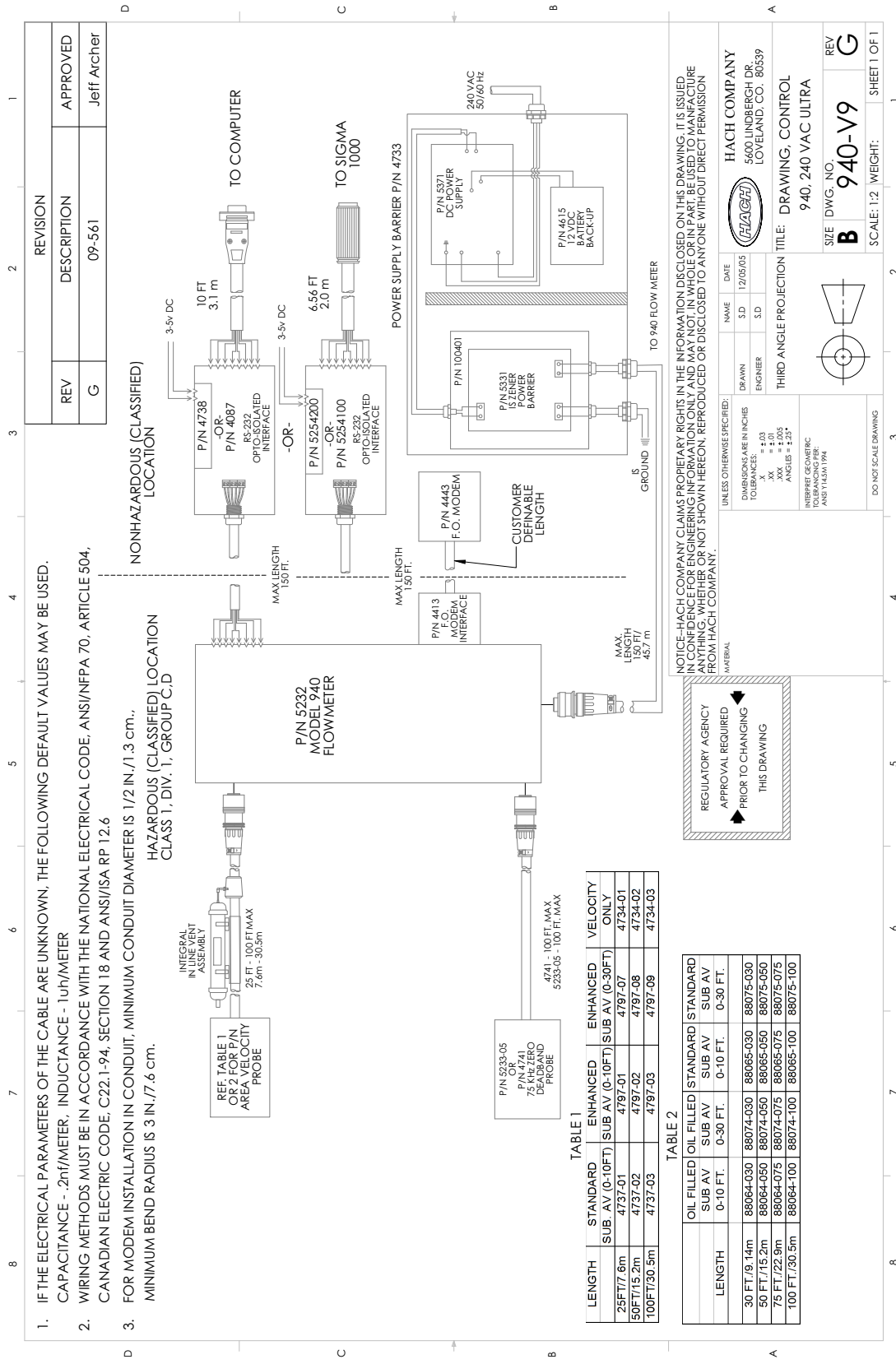

Figure 10 Control Drawing 940-V9

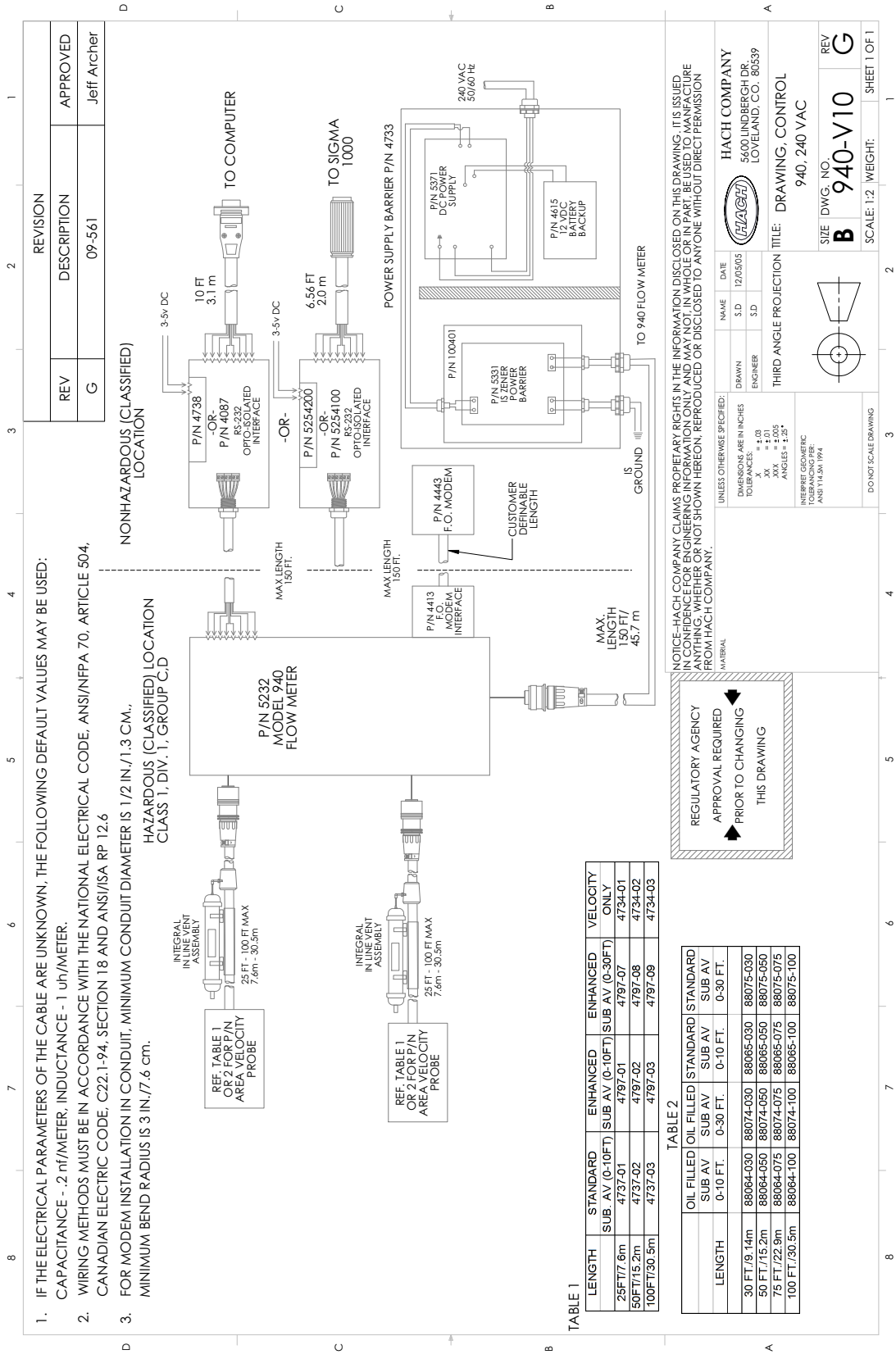

Figure 11 Control Drawing 940-V10



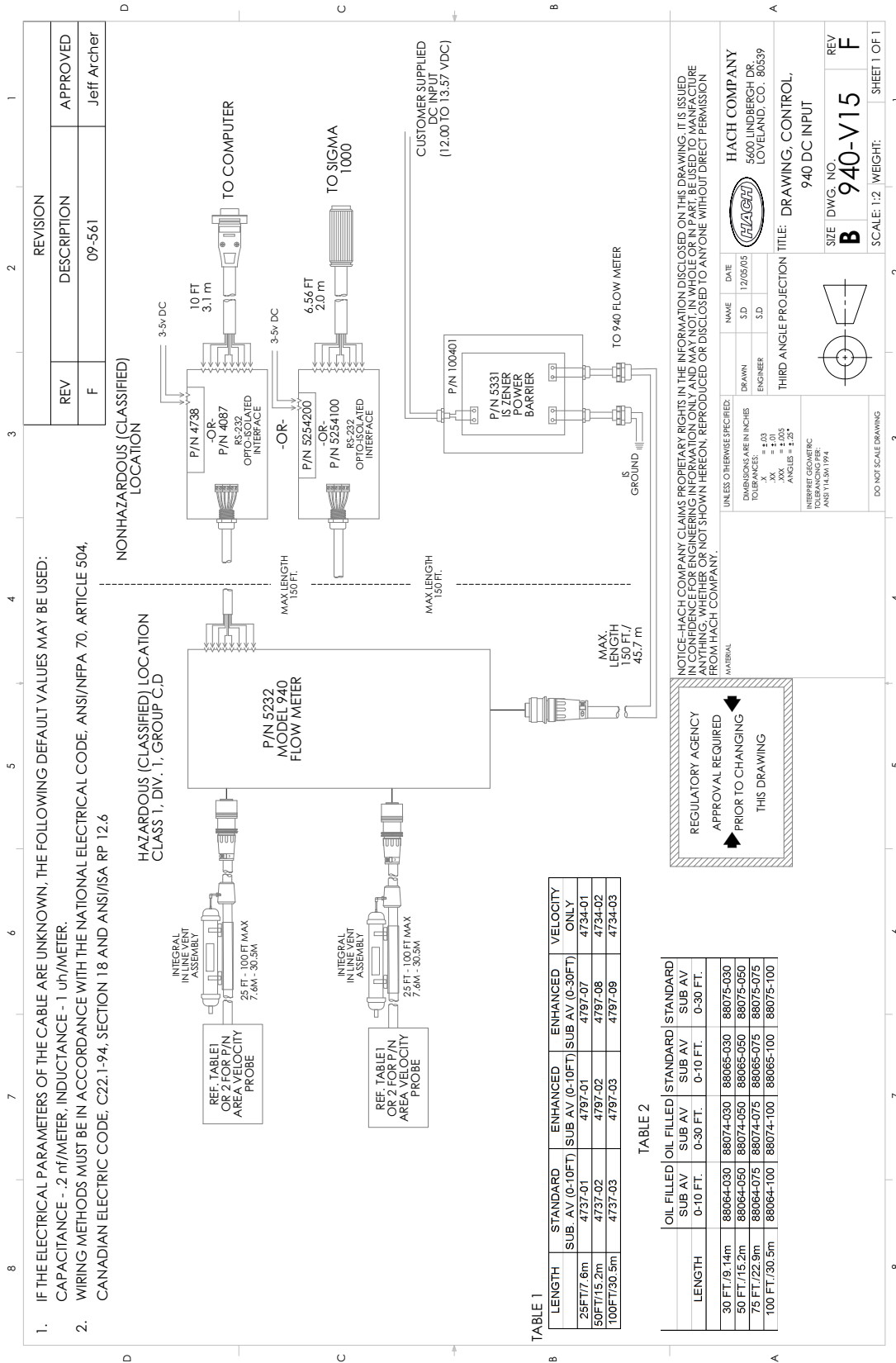

Figure 13 Control Drawing 940-V15

## 4.2 Mounting the flow meter

When mounting the flow meter, remember to:

- **Mount the meter so that the connectors face down.** The end of the meter that contains the batteries should face up. If the connectors face up, they may corrode and allow water to seep into the instrument. Refer to [Figure 14 on page 29](#).
- When not in use, cover the connectors with their protective caps to prevent corrosion.

Use the appropriate manhole support bracket/spanner bar. See [Replacement Parts and Accessories on page 67](#).

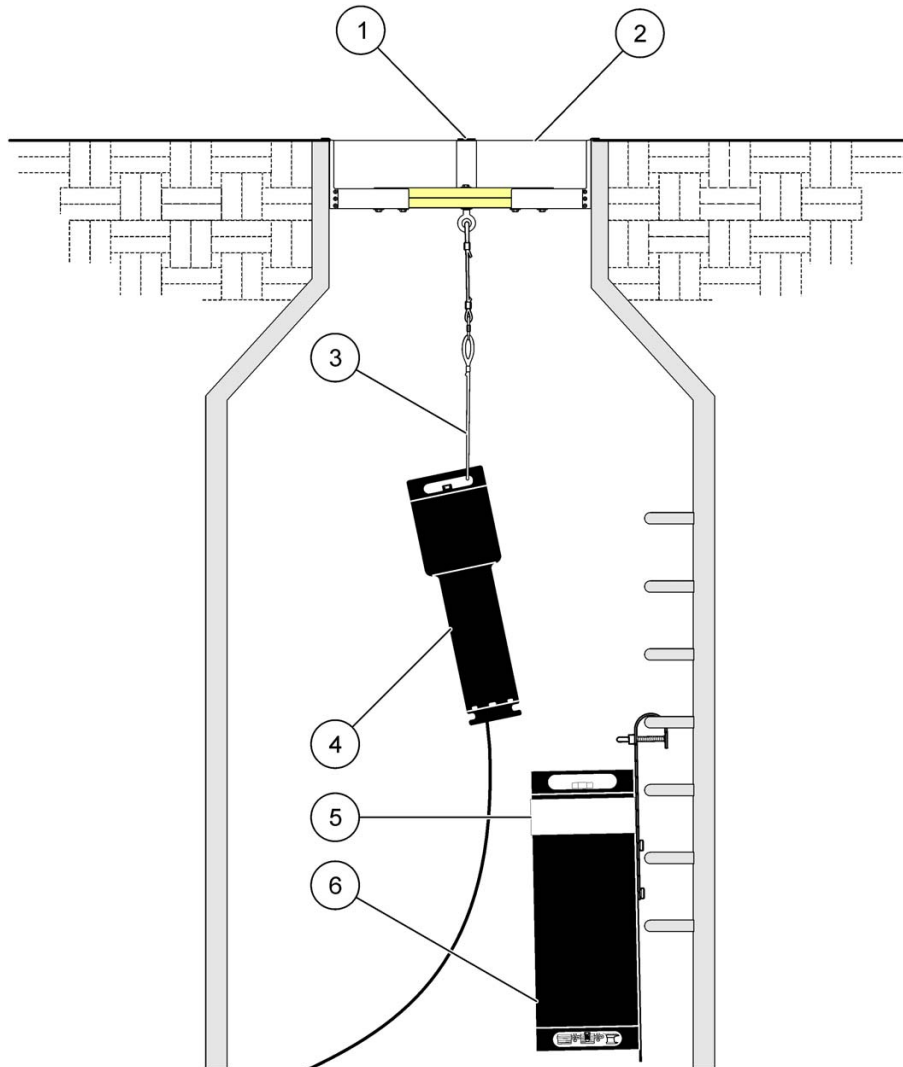

Figure 14 Installation options

1 Instrument Support Bracket (Cat. No. 5713000)	4 911 flow meter
2 Manhole cover	5 Wall/Ladder Mount Suspension Bracket (Cat. No. 4874 and Cat. No. 4839)
3 Suspension harness (Cat. No. 4920)	6 940 flow meter

### 4.3 Installing the Batteries

Never short circuit, puncture, deform, or incinerate any of the battery packs used in the 911 or 940 flow meters. Proper precautions must be observed in the handling, shipping, and disposal of battery packs.

#### 4.3.1 Installing the Battery Pack in the 940

**DANGER**

**Never install, remove, or charge batteries in a hazardous location.**

**DANGER**

**Vous ne devez jamais installer, retirer ou recharger les batteries dans un environnement dangereux.**

The steps mentioned below give the installation procedure of the battery pack in the 940.

1. Loosen the  $\frac{5}{16}$ " socket head cap screw in the center of the bottom end cap.
2. Lift the end cap off.
3. Remove the two thumbscrews securing the battery retaining plate and unlatch the two rubber hold down straps.
4. Place the battery pack (Cat. No. 6608500) inside the battery compartment ([Figure 15](#)).
5. Place the two rubber hold down straps across the battery to secure the battery in place.
6. Attach the battery power connector to the flow meter power connector.
7. Both connectors are physically polarized.
8. Try to pull the two connectors apart gently, after placing the two connectors together, to ensure that they are latched together, . Do not use excessive force or permanent damage to the connectors may occur.
9. Reattach the battery retaining plate and install the two thumbscrews.
10. Replace the flow meter end cap and retighten the  $\frac{5}{16}$ " socket head cap screw.

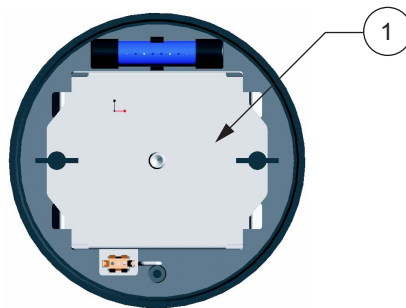

Figure 15 940 Flow Meter Battery Pack

1 Battery Pack Location
-------------------------



### 4.3.2 Installing the Battery Pack in the 911

**DANGER**

*Use only exact replacement battery packs purchased directly from the factory or a factory authorized outlet. Any unauthorized battery substitution will void the intrinsically safe design and approval of the unit and could result in fire or explosion.*

**DANGER**

*Utilisez exclusivement des batteries de recharge identiques que vous achetez directement auprès de l'usine ou d'un point de vente agréé par celle-ci. Tout remplacement non autorisé d'une batterie annule la conception à sécurité intrinsèque et l'agrément de l'appareil, et peut provoquer un incendie ou une explosion.*

**DANGER**

*Never install, remove, or charge batteries in a hazardous location.*

**DANGER**

*Vous ne devez jamais installer, retirer ou recharger les batteries dans un environnement dangereux.*

The entire battery assembly unscrews and separates to access the battery connector (Cat. No. 5160-01). Follow the steps below to install the battery pack in the 911.

1. Hold the 911 Flow Meter by the handle on the end opposite of the interface connectors and twist counter-clockwise to open.
2. Remove the rechargeable battery pack. Recharge or dispose of the battery.
3. Reinstall the rechargeable battery. Attach the battery connector to the center mounted connector at the bottom of the 911 case (Figure 16).

*Note: Both connectors are physically polarized.*

4. Place the two connectors together. Gently try to pull the two connectors apart to ensure that the connectors are securely latched together. Do not use excessive force or permanent damage to the connectors may occur.
5. Tighten the screw of the battery pack assembly onto the flow meter.

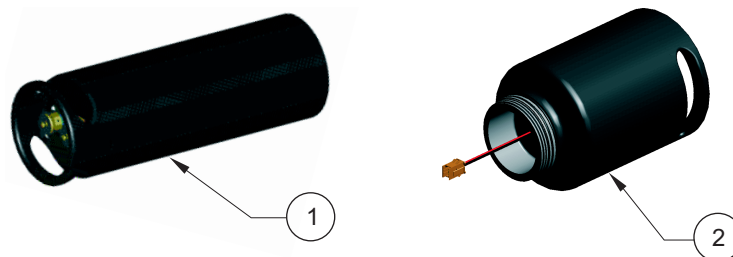

Figure 16 911 Flow Meter Case and Battery Packs

1 911 Flow Meter Case	2 12 Amp-hour rechargeable gell cell battery pack.
-----------------------	--

### 4.3.3 Battery Compartment Desiccant

The battery compartment in both the 911 and 940 Flow Meters is kept dry with a small desiccant cartridge to avoid moisture damage to the batteries and power circuitry (Figure 17 and Figure 18).

When the beads are blue they can remove moisture from the enclosure. When they turn pink, they cannot absorb any more moisture. When the blue desiccant turns pink, replace the desiccant.

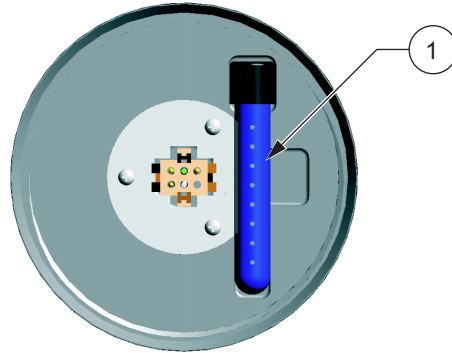

Figure 17 911 Case, Battery End with Inserted Desiccant

1 Desiccant

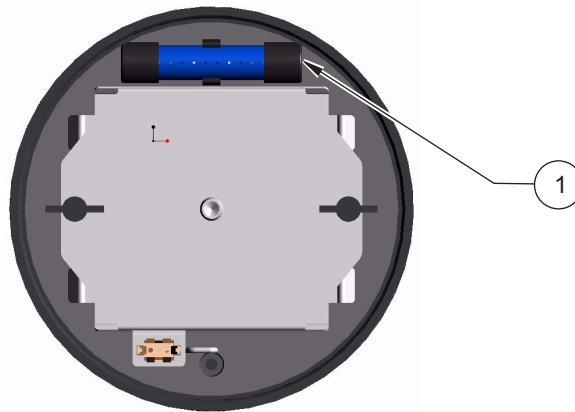

Figure 18 940 Case, Battery End with Inserted Desiccant

1 Desiccant

### 4.3.4 Estimating the Battery Life

When using the battery pack, battery life is based on:

- Number of sensors installed (more sensors decrease battery life).
- Recording intervals (longer intervals increase battery life).
- Temperature (colder temperatures decrease battery life).
- Site hydraulics (second order effect caused by excessive turbulence).
- Interval between downloads.

Table 5 provides typical expected battery life for 911 and 940 Flow Meters:

**Table 5 Battery Life**

Model	Battery Type	Battery Life in Days
911	12 Amp-hour gel cell (Cat. No. 5160-01)	90
940	Rechargeable lithium battery (Cat. No. 6608500)	Typically 330

Batteries for the 911 and 940 flow meters should last as listed above under the following conditions:

- 15 minute logging intervals
- 1 level channel and 1 velocity channel logged
- Data downloaded once per week
- 10 °C (50 °F) ambient temperature
- Also affected by site conditions

### 4.3.5 Recharging the Lithium Ion Battery Pack for Model 940

**DANGER**

*Use only exact replacement battery packs purchased directly from the factory or a factory authorized outlet. Any unauthorized battery substitution will void the intrinsically safe design and approval of the unit and could result in fire or explosion.*

**DANGER**

*Utilisez exclusivement des batteries de rechange identiques que vous achetez directement auprès de l'usine ou d'un point de vente agréé par celle-ci. Tout remplacement non autorisé d'une batterie annule la conception à sécurité intrinsèque et l'agrégation de l'appareil, et peut provoquer un incendie ou une explosion.*

**DANGER**

*Never install, remove or charge batteries in a hazardous location.*

**DANGER**

*Vous ne devez jamais installer, retirer ou recharger les batteries dans un environnement dangereux.*

To recharge the 940 Lithium Ion Battery Pack (6608500):

1. Move the 940 Flow Meter to a non-hazardous location.
2. Remove the battery pack from the 940 Flow Meter as described in [section 4.3.1 on page 30](#).
3. Inspect the battery pack and the battery connection for any damage. Do not attempt to use or repair a damaged battery pack assembly.
4. Make sure that the charging voltage switch on the back of the charger is set to 16.4 V.
5. Plug the charger (6678000) into a standard 120 VAC wall outlet. The green power LED will illuminate.
6. Connect the charger to the battery pack using the battery charger and battery pack cables. The yellow charge LED indicator will illuminate. See [Table 6](#) for the Lithium Ion battery charging status. A completely discharged battery pack will charge in approximately 8 to 12 hours.

**Table 6 Battery pack charging status**

Charge LED Indicator	Battery Condition
Flashing	Deeply discharged or needs replacement <sup>1</sup>
Illuminated	Charging
Off	Charged

<sup>1</sup> If the charge indicator LED does not stop flashing within 1 hour the battery pack is shorted and should be disposed of properly.

7. Install the battery pack in the 940 Flow Meter as described in [section 4.3.1 on page 30](#).

### 4.3.6 Recharging the Battery Pack for Model 911

**DANGER**

*Use only exact replacement battery packs purchased directly from the factory or a factory authorized outlet. Any unauthorized battery substitution will void the intrinsically safe design and approval of the unit and could result in fire or explosion.*

**DANGER**

*Utilisez exclusivement des batteries de recharge identiques que vous achetez directement auprès de l'usine ou d'un point de vente agréé par celle-ci. Tout remplacement non autorisé d'une batterie annule la conception à sécurité intrinsèque et l'agrément de l'appareil, et peut provoquer un incendie ou une explosion.*

**DANGER**

*Never install, remove or charge batteries in a hazardous location.*

**DANGER**

*Vous ne devez jamais installer, retirer ou recharger les batteries dans un environnement dangereux.*

To recharge the 911 Lithium Ion Battery Pack (5160-01):

1. Move the 911 Flow Meter to a non-hazardous location.
2. Remove the battery pack from the 911 Flow Meter as described in [section 4.3.2 on page 31](#).
3. Inspect the battery pack and the battery connection for any damage. Do not attempt to use or repair a damaged battery pack assembly.
4. Plug the charger (913) into a standard 120 volt wall outlet.
5. Connect the charger to the battery pack using the battery charger and battery pack cables. A completely discharged battery pack will charge in approximately 8 to 12 hours. Do not overcharge.
6. Install the battery pack in the 911 Flow Meter as described in [section 4.3.2 on page 31](#).

## 4.4 Wiring the RS232 Interface

**DANGER**

*All connections to the flow meter must be made in a non-hazardous location.*

**DANGER**

*Tous les raccordements au débitmètre doivent être effectués dans un environnement qui ne présente aucun danger.*

All RS232 interface wiring must follow the installation drawings in [section 4.1 on page 15](#).

### 4.4.1 RS232 Serial Port

**DANGER**

*The RS232 Opto-Isolated Interface must be located in a non-hazardous location.*

**DANGER**

*L'interface à isolation optique RS232 doit se trouver en un emplacement non dangereux, conformément aux schémas de contrôle de l'installation.*

*Note: A PC or laptop must be used in a non-hazardous location.*

The high speed RS232 serial port communicates with a PC via an optically isolated interface (Figure 19 on page 35). The Opto-Isolated Interface (Cat. No. 4087) is used only for data downloading and remote programming. This interface isolates the energy potential in the PC from hazardous locations and from the 911 or 940 Flow Meters.

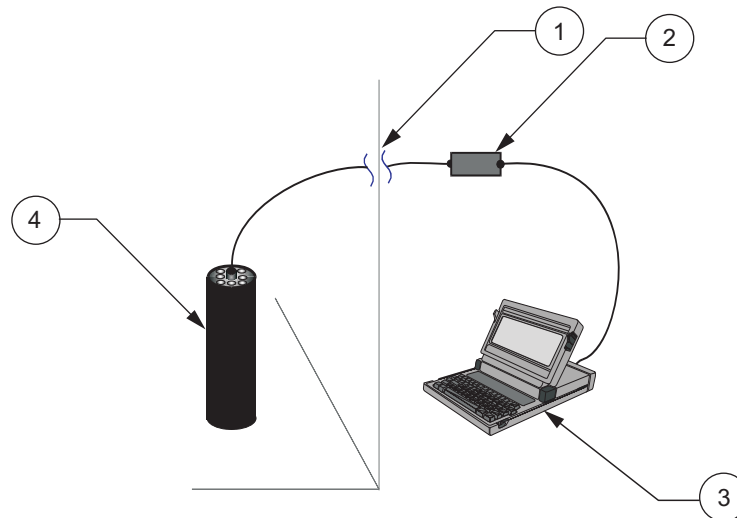

Figure 19 RS232 Communications Setup

<p><b>1</b> Use “approved” seal to minimize passage of gases or vapors from a hazardous location to a non-hazardous location.</p>	<p><b>3</b> PC compatible laptop or desktop located in a non-hazardous location for downloading data</p>
<p><b>2</b> RS232, Opto-Isolated Interface in a non-hazardous location (Cat number 4087)</p>	<p><b>4</b> 940 or 911 Flow Meter in a hazardous location</p>

**DANGER**

*Route the cable through an approved seal to prevent migration of dangerous fumes or vapors from the hazardous location to the non-hazardous location.*

**DANGER**

*Acheminez le câble à travers un joint approuvé afin d'empêcher la migration de*

## Meter Installation

*fumées ou vapeurs dangereuses de l'emplacement dangereux vers l'emplacement non dangereux.*

Follow the steps mentioned below to route the RS232 Serial Port

1. Attach the cable with the round connector from the Opto-Isolated Interface to the connector on the 911/940 Flow Meter labelled RS232.
2. Attach the cable with a rectangular connector to the appropriate serial COM port on the PC or laptop.

### 4.5 Wiring the Sampler Interface on Model 940

**DANGER**

*All connections to the flow meter must be made in a non-hazardous location.*

**DANGER**

*Tous les raccordements au débitmètre doivent être effectués dans un environnement qui ne présente aucun danger.*

All sampler interface wiring must follow the installation drawings in [section 4.1 on page 15](#). Refer to [Table 7](#) and [Figure 20](#).

**Table 7 Sampler Cable Connector Pin Assignments and Description**

Pin Letter	Wire Color	Description	Rating
A (+12 V dc)	White	+12 V dc input	—
B (Ground)	Blue	Provides the ground line that is used in conjunction with the other signals on this connector.	—
C Flow Pulse Output	Yellow	Used in conjunction with Pin B (ground) to signal a sampler that a pre-determined amount of flow has accumulated.	+8 V dc. Output current is 100 mA dc (max) with a duration of 500 ms.
D Sampler Start	Black	Used to “wake up” a wastewater sampler when a level and/or rainfall set-point condition is met so that it can begin sampling. Used in conjunction with Pin B (ground), this line is normally allowed to float and is switched to ground (by transistor) once the set-point conditions are met.	+24 V dc (max)
E Event Input	Red	Confirms that a sample has been collected. The time and date of each water sample appears on the data printout when downloaded using a Data Transfer Unit or Sigma Support Software.	+12 V dc (max) minimum 3 second pulse.
F Bottle Number Input	Green	Used in conjunction with the “Event Input” signal described above. It tells the flow meter which bottle was used and when a sample was taken. This information appears in the data printout (see “Sample Times and Dates”) when downloaded using a Data Transfer Unit or Support Software. Bottle Number signal description If the Program Complete Output (Pin F of the auxiliary connector) is disabled on the sampler, then it is used to transmit the bottle number to the connected device. Time A = 200 ms Time B = 100 ms (50 ms HI 50 ms LO) If a sample attempt fails, the first pulse width 'B' is 150 ms HI and 50 ms LO. If Sample Distribution is programmed for multiple bottles per sample mode, only the first bottle number of the set is transmitted via Pin F.	—

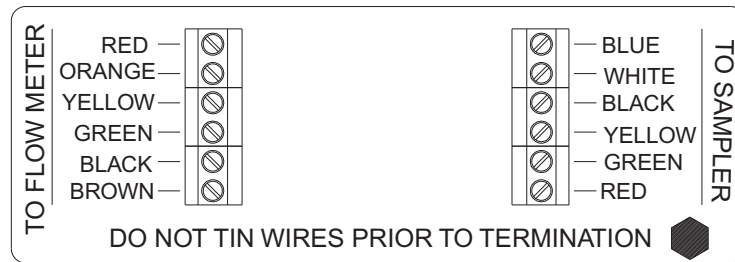

Figure 20 Sampler Interface Wiring

## 4.6 Sampler Receptacle (940 Only)

**DANGER**

*Do not attempt to connect any sampler to the 940 Flow Meter without the use of the Optically Isolated Sampler Interface (Cat. No. 4274). Failure to do so may result in fire or explosion.*

**DANGER**

*Le raccordement d'un échantillonneur quelconque à un débitmètre 940 sans utilisation de l'interface d'échantillonneur à isolation optique (No. Cat. 4274) annule à la fois la garantie et l'agrément de sécurité intrinsèque du débitmètre, et peut provoquer un incendie ou une explosion. Reportez-vous aux schémas de contrôle de l'installation.*

The optional “sampler” port lets the user to connect a 940 flow meter to a Sigma wastewater sampler (Figure 21). The option provides several features:

- Flow proportional sampling
- Storm water trigger, based on level, useful for EPA NPDES permitting program.

- Sample history logging.

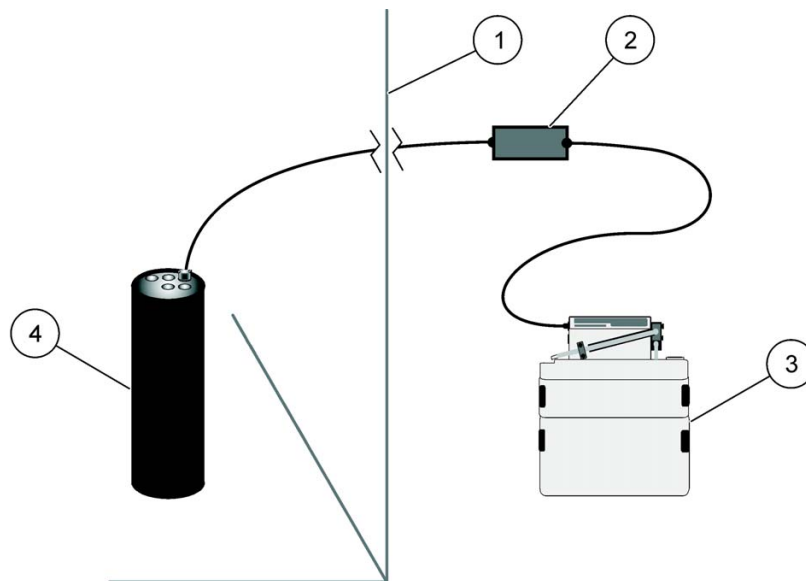

Figure 21 Sampler Communications

<p><b>1</b> Use “approved” seal to minimize passage of gases or vapors from hazardous location to non-hazardous location.</p>	<p><b>3</b> Sampler located in a non-hazardous location</p>
<p><b>2</b> Optically Isolated Sampler Interface (Cat. No. 4274) in a non-hazardous location</p>	<p><b>4</b> 940 Flow Meter in a hazardous location</p>

### 4.6.1 Connecting the Sampler Cable to a 940 Flow Meter

*Note: The sampler must be located in a non-hazardous location.*

1. Connect the Optically Isolated Sampler Interface (Cat. No. 4274) between the 940 sampler receptacle and the samplers auxiliary receptacle.
2. Program the sampler for Special Output/Sample Output.

### 4.6.2 Connecting a Non-Sigma Sampler to a 940 Flow Meter

**DANGER**

**Do not attempt to connect any sampler to the 940 Flow Meter without the use of the Optically Isolated Sampler Interface (Cat. No. 4274). Failure to do so may result in fire or explosion.**

**DANGER**

**Le raccordement d'un échantillonneur quelconque à un débitmètre 940 sans utilisation de l'interface d'échantillonneur à isolation optique (No. Cat. 4274) annule à la fois la garantie et l'agrément de sécurité intrinsèque du débitmètre, et peut provoquer un incendie ou une explosion. Reportez-vous aux schémas de contrôle de l'installation.**

The Optically Isolated Sampler Interface can also be used with samplers produced by other manufacturers. In many cases a non-Sigma sampler may be connected to the Optically Isolated

Sampler Interface without any modifications or alterations

If a non-Sigma sampler is not compatible with the connector on the end of the sampler interface cable it may be necessary to remove the existing cable from the sampler interface and use the other manufacturer's sampler cable.



**Note:** *It is the installers responsibility to ensure compatibility and proper connection of a non-Sigma sampler to the Optically Isolated Sampler Interface.*

1. Remove the cover from the Optically Isolated Sampler Interface.
2. Disconnect all the wires from the terminals labeled J4 through J6. Do not remove the wires from terminals labeled J1 through J3.
3. Loosen the compression nut on the sampler cable connector and remove the cable from the interface.
4. Insert the other manufacturer's sampler cable end into the cable connector of the Optically Isolated Sampler Interface.



## Section 5 Software and Communications

---

### 5.1 Required Software

Programming and data retrieval are performed via an IBM compatible personal computer (computer must have a serial port, USB is not supported) using an Optically Isolated Interface with one of the following software packages:

- InSight® Data Analysis Software is a program for small- to medium -sized flow monitoring jobs.
- Flo-Center Integrated Sewer System Management Software provides high-end, automated data collection and automated batch report processing, using an unlimited number of meters.
- Modicon Modbus Protocol (940 Only)
- Flo-Ware for Windows (911 Only)

### 5.2 Programming and Analysis Options

- Built-in flow equations
- Storage of 116,000 data points in battery backed RAM memory
- Storm water sampling trigger option (940 only)
- Flow proportional output option (940 only)

For details on programming the 911 or 940 Flow Meter, refer to the software manual.



**DANGER**

*Only qualified personnel should conduct the tasks described in this section of the manual.*

**DANGER**

*Seul un technicien qualifié peut effectuer les tâches d'installation décrites dans cette section du manuel.*

**DANGER**

*All connections to the flow meter must be made in a non-hazardous location.*

**DANGER**

*Tous les raccordements au débitmètre doivent être effectués dans un environnement qui ne présente aucun danger.*

### 6.1 Downlook Ultrasonic Sensor

The downlook ultrasonic sensor is mounted over the flow stream at the proper location for level measurement for the primary device. See [Appendix A on page 75](#) for more information. The transducer emits a pulse of sound at a high frequency and awaits for the echo to return from the surface of the water. The time it takes for this echo to return is relative to the distance between the transducer and the surface water. As the level in the flow stream increases, the time it takes for the echo to return to the transducer decreases (distance is shorter).

By continuously transmitting these pulses and timing the returning echoes, the sensor measures the level of the liquid on the flow stream. After measuring the level, the microprocessor converts the level reading to a flow rate based on the user-defined characteristics of the primary device.

#### 6.1.1 Installing the Downlook Ultrasonic Sensor

**Note:** *Do not suspend the sensor by the cable. Only use appropriate mounting hardware.*

Site selection can greatly enhance system performance. Several important factors should be considered when installing the downlook ultrasonic sensor at any primary device.

- Locate the ultrasonic sensor at the proper head measurement point for that primary device.
- Determine the appropriate sensor height.
- Suspend the ultrasonic sensor over the center of the flow stream where there is the least surface turbulence.
- Mount the sensor to a stable, secure location, isolated from vibration.

##### **Invisible Range**

The 940 Flow Meter is equipped with an invisible range (adjustable deadband feature) to prevent false echoes from tops of channel walls, ladder rungs, shelves, etc. A user selected range is defined which is invisible to the flow meter. Extend the invisible range to where it meets or overlaps the highest expected level in the channel. Refer to [Figure 22 on page 44](#). A gap of at least 5 cm (2 in.) should be left between the invisible range and the highest expected level. The minimum distance must be at least 29 cm (11 in.) The

## Sensor Installation

sensor is “blind” to anything closer than the deadband and stops reading level when the distance is shorter than that.

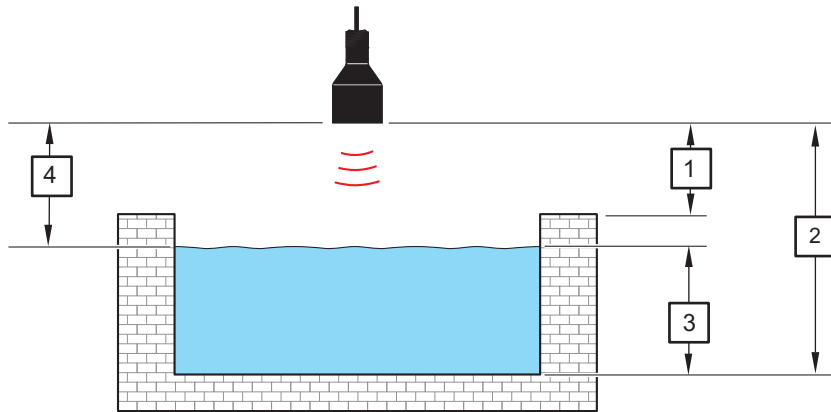

Figure 22 Invisible Range

1	Maximum Range	3	Highest expected water level
2	Minimum Distance (must be at least 11 in. (29 cm))	4	Invisible Range (set to ignore tops of channel walls)

### Beam Angle

The beam angle from the bottom of the ultrasonic sensor spreads out at an angle of 5° for the 75 kHz sensor as it travels away from the sensor. Therefore, if the sensor is mounted too high above a narrow channel, the beam may be wider than the channel when it reaches the bottom of the channel. This can cause false echoes from the tops of the channel walls rather than from the water surface. To prevent false echoes, determine the appropriate sensor height so that the entire beam falls within the channel and does not strike any obstructions.

### Beam Width Formulas

The maximum beam width for a given distance from the sensor can be calculated as follows:  $0.087 \times \text{distance from sensor}$ . Refer to [Figure 23](#) and [Table 8 on page 45](#).

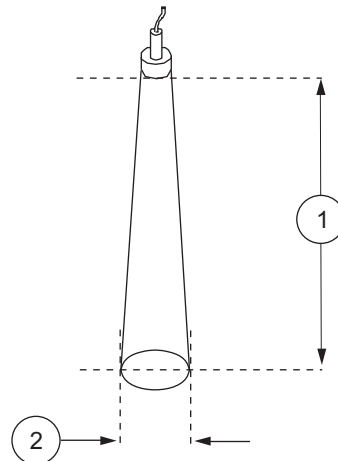

Figure 23 Beam Width as Distance from Transducer Increases

1	Distance from Transducer	2	Beam Width
---	--------------------------	---	------------

### Protecting the Sensor

Keep the face of the sensor free of accumulating grease and dirt. Since the 940 Flow Meter listens for the returning echo, a coated sensor will not be able to accurately detect the echo and may provide inaccurate level measurement.

Table 8 Beam Angle Spread by Distance

Distance from Target (in.)	75 KHz Beam Width (in.) w/ Horn
11 (27.9 cm)	0.96 (2.4 cm)
12 (30.5 cm)	1.05 (2.67 cm)
13 (33.0 cm)	1.14 (2.9 cm)
14 (35.6 cm)	1.2 (3.1 cm)
15 (38.1 cm)	1.31 (3.3 cm)
16 (40.6 cm)	1.4 (3.6 cm)
17 (43.2 cm)	1.5 (3.8 cm)
18 (45.7 cm)	1.6 (4.0 cm)
19 (48.3 cm)	1.7 (4.2 cm)
20 (50.8 cm)	1.75 (4.5 cm)
21 (53.3 cm)	1.83 (4.6 cm)
22 (55.9 cm)	1.9 (4.9 cm)
23 (58.4 cm)	2.0 (5.1 cm)
24 (61.0 cm)	2.1 (5.3 cm)
36 (91.4 cm)	3.1 (8.0 cm)
48 (1.2 m)	4.2 (10.6 cm)
60 (1.5 m)	5.2 (13.3 cm)
72 (1.8 m)	6.3 (16.0 cm)
84 (2.1 m)	7.3 (18.6 cm)
96 (2.4 m)	8.4 (21.3 cm)
108 (2.7 m)	9.4 (24.0 cm)

#### 6.1.1.1 Mounting the Ultrasonic Sensor

**Note:** To prevent mechanical vibration ensure that the supplied isolation washers are installed as shown in [Figure 24 on page 46](#).

Several brackets are available for mounting the sensor to a fixed location such as a wall or floor. See [Figure 24 on page 46](#) and [Figure 25 on page 47](#). For mounting options see [Section 8 on page 67](#). Each bracket utilizes the 1.9 cm (¾ in.) NPT connector on the sensor to secure the sensor to the bracket. Always level the sensor using a level. The maximum water level must be below the deadband to ensure accurate readings.

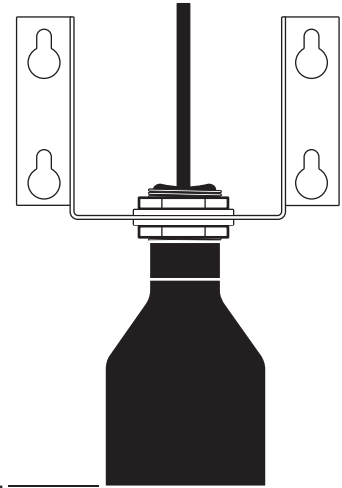
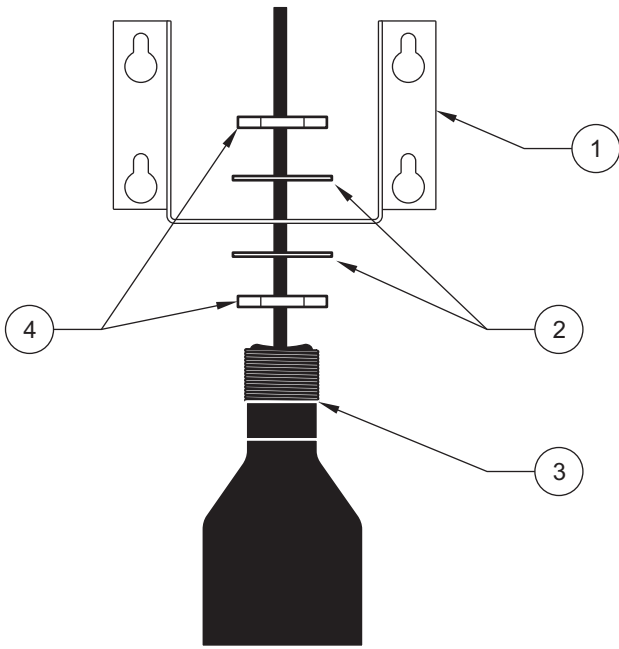

This surface must be level. \_\_\_\_\_

**Figure 24 Permanent Bracket and Isolation Washers**

<b>1</b> Wall/Rail Mount Bracket (Cat. No. 2974)	<b>3</b> Downlook Ultrasonic Sensor
<b>2</b> Isolation Washers (Cat. No. 6820)	<b>4</b> 1 inch x 0.25 Hex Nuts (Cat. No. 1429)



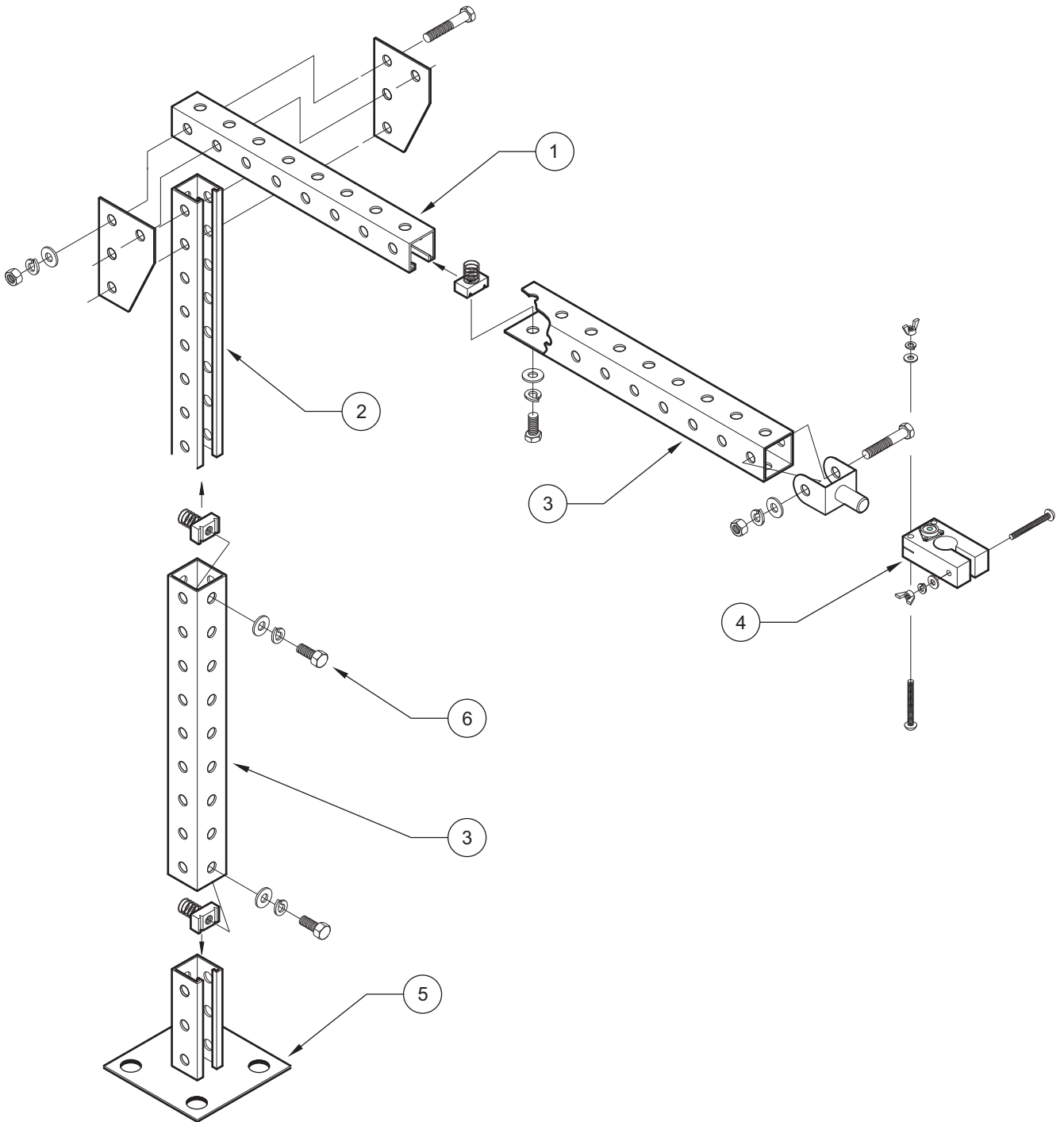

Figure 25 Adjustable Mounting Bracket (Cat. No. 2904)

<b>1</b>	14.75 inches (Cat. No. 3047)	<b>4</b>	Sensor Mounting Clamp <sup>1</sup>
<b>2</b>	15.25 inches (Cat. No. 3046)	<b>5</b>	14 cm (5.5 in.) tall (Cat. No. 3108)
<b>3</b>	16.625 inches (2) (Cat. No 3048)	<b>6</b>	Horizontal and vertical sections are fully adjustable <sup>2</sup>

<sup>1</sup> Sensor Mounting Clamp (with built-in bubble level) Sensor adjusts to any required level.

<sup>2</sup> Loosen the bolt, slide the section to the desired distance and re-tighten the bolt.

## Sensor Installation

### 6.1.2 Troubleshooting the Downlook Ultrasonic Sensor Installation

Problem/Error Message	Solutions
<b>Ultrasonic Failure (No signal from sensor)</b>	Check the connection between the flow meter and the sensor.
	Check the sensor cable for cuts or nicks.
	Recalibrate the sensor. Look for unusual temperatures or the inability for a new calibrated level to be read.
	Try a different sensor on the same flow meter to rule out instrument problems, and try a different flow meter with the same sensor to rule out sensor problems.
<b>Echo Loss (Flow meter does not get a return signal from the sensor)</b>	Check for excessive foam on the water surface. Foam may cause sound waves to be absorbed rather than reflected.
	Check the sensor height. See <a href="#">Figure 22 on page 44</a> .
	Check the sensor cable for cuts or nicks.
	Check the connection between the flow meter and the sensor.
	Make sure that the sensor is level. The sensor must be level for proper return of the signal.
	Try shielding the transducer from convection currents.
	Repeat the temperature calibration procedure. If the unit reads extreme high or low temperatures, the sensor may have a bad temperature.
Try a different sensor on the same flow meter to rule out instrument problems, and try a different flow meter with the same sensor to rule out sensor problems.	
<b>Convection Currents</b>	Check to see if convection components between the sensor target are present. If these components are present, install a shield around the sound beam to eliminate temperature variation due to convection currents. The system is designed with averaging routines to help mitigate this problem.
	Check for excessive foam and oil. While the 940 Flow Meter is designed with an AGC (Automatic Gain Control) scheme to reduce these factors, it is recommended that sites without these anomalies be selected.
<b>Obstructions</b>	Use the invisible range to select targets beyond peripheral obstructions. Care must be taken to set the range higher than the expected level.
<b>Transducer Ringing (False return echoes mask “real” echoes)</b>	Try moving the transducer farther from the liquid.
	Check under the transducer for obstructions. This includes the front and sides of the transducer.
	Check the face of the transducer for a coating. This is rare, but cleaning the transducer face may correct the problem. If this is a constant problem due to site conditions, coat the face of the sensor with a thin film of silicone grease to keep debris from clinging.
	Make sure that the proper rubber isolation washers are used on the mounting bracket. The transducer can resonate against steel mounting rails. See <a href="#">section 6.1.1.1 on page 45</a> .
<b>RS485 Time Out (Flow meter did not receive data within the specified time)</b>	If the CPU has trouble communicating with the ultrasonic board, RS485 time outs may occur. Wait a few minutes and see if the trouble has stopped. If it continues, a problem with the ultrasonic, velocity, or CPU board may exist.
	If the logging interval is 1 or 2 minutes, or if conditions are poor, or if the problem continues indefinitely, try increasing the logging interval to capture more signals.
	When using a combination of area velocity and ultrasonic sensors, this condition may occur more frequently if site conditions are less than ideal. This is not necessarily an indication of a defective sensor. This condition may occur occasionally.
	Check to see if pins are shorted. Do not short pins on receptacle to avoid damage.

## 6.2 In-Pipe Ultrasonic Sensor

The in-pipe ultrasonic sensor is used in pipes where level measurement near the top of the pipe is desired. The sensor reads the level until the liquid reaches the bottom of the sensor housing. The in-pipe sensor is not recommended for weir or flume applications due to limited range, but may be desirable in some applications.

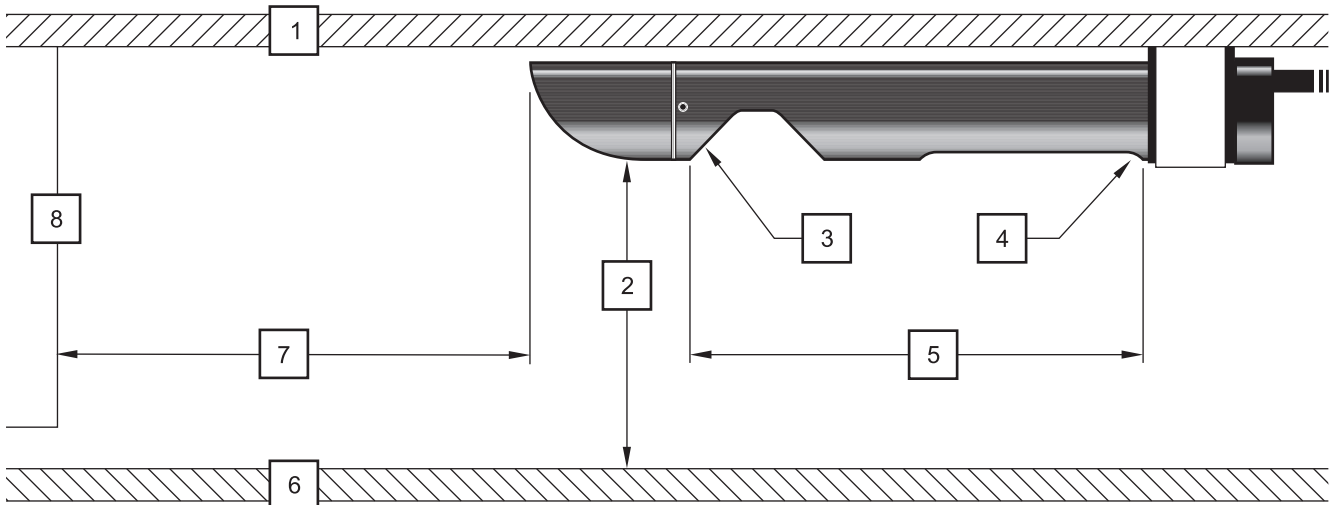

Figure 26 Side View of In-Pipe

1 Pipe Ceiling	5 Internal Deadband (18.3 cm (7.2 inches))
2 Distance from Sensor (Range: 0.2 in. to 5 ft)	6 Pipe Floor
3 45° Deflector	7 Minimum distance to reflecting obstruction (46 cm (18 in.))
4 Ultrasonic Sensor	8 Reflecting Obstruction

### 6.2.1 Mounting the In-Pipe Sensor

- Mount the sensor over the center of the flow stream where the surface turbulence is minimized ([Figure 27 on page 50](#)).
- Mount the sensor 46 cm (18 in.) away from obstructions located in front of the in-pipe sensor to prevent inaccurate liquid level readings ([Figure 26](#)).
- Level the sensor using the built-in bubble level.
- Ensure the isolation gasket is in place and the mounting bracket thumbscrews are finger-tight to avoid sensor ringing.
- Install the sensor within 1.5 m (5 ft) of the lowest expected level (the maximum range of the sensor).

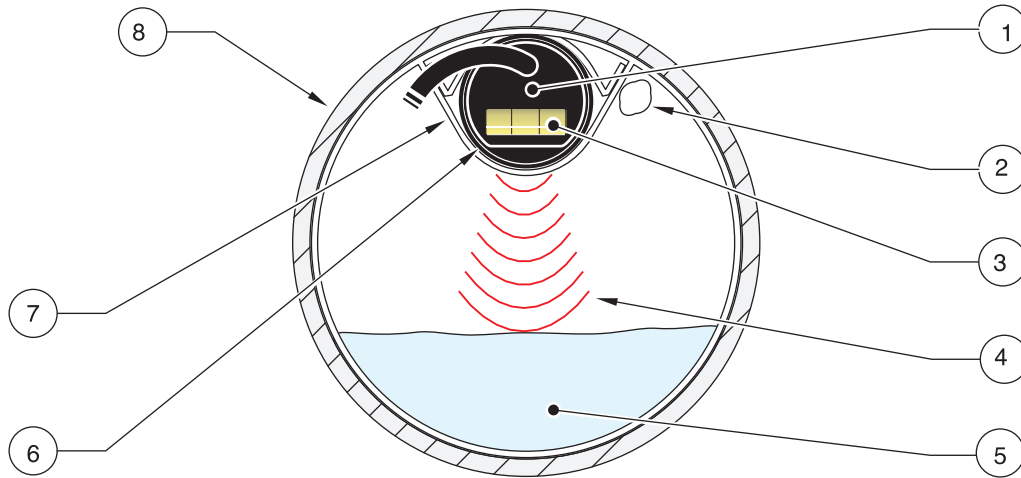

Figure 27 End View of In-Pipe

1	Sensor	5	Wastewater
2	Bracket Thumbscrew	6	Vibration Isolation Gasket
3	Bubble Level	7	Mounting Clip
4	Sound Waves	8	Pipe (size may vary)

### 6.2.2 Angling the Beam

The narrow beam of sound that emanates from the bottom of the in-pipe ultrasonic sensor spreads out at an angle of  $\pm 12^\circ$  (-10 dB) as it travels away from the sensor. This means that if the sensor is mounted too high above a narrow channel, the beam may be too wide when it reaches the bottom of the channel. This may cause false echoes from the sides on the channel walls.

### 6.2.3 Calibrating the In-Pipe Ultrasonic Sensor

Calibrate the in-pipe sensor each time the sensor is installed at a new site. Calibrate the in-pipe via one of two methods; Liquid Depth or Sensor Height. Each method has its own advantages and disadvantages. Liquid Depth calibration is the recommended calibration method; use the sensor height method **only** when Liquid Depth calibration is not an option. An Invisible Range can also be set which allows the transducer to ignore reflections from obstructions between the sensor and the water surface, such as ladder rungs, channel side walls, etc.

#### 6.2.3.1 Calibrating the Temperature

The speed of sound in air varies with the temperature of air. The in-pipe sensor is equipped with temperature compensation to help eliminate the effect of temperature variation under normal site conditions. Enter the ambient air temperature at the transducer location. For optimum results, allow enough time (100 minutes) to ensure that the sensor is at equilibrium with the surrounding air temperature.

### 6.2.3.2 Calibrating the Liquid Depth

Liquid depth calibration requires knowing the level or the depth of the liquid in the channel that is contributing to the flow. Liquid depth calibration is the recommended calibration method for the in-pipe sensor. Take a physical measurement of the liquid depth and enter the value into the application software. For a dry channel enter 0 depth.

### 6.2.3.3 Calibrating the Sensor Height

Sensor height calibration is generally used when access to the primary device is difficult (such as confined space entry in a manhole) or when there is no liquid flow during installation of the flow meter. This calibration method requires knowing the distance between the zero flow point and the bottom of the sensor. In a round pipe the zero flow point is typically the invert or bottom of the pipe. Further, compensation is required for the invisible range (internal deadband) in the sensor housing. Measurement uncertainty increases to 1.28 cm (0.042 ft) for a  $\pm 30$  cm ( $\pm 1$  ft) change in level from the calibration point. Use this method **ONLY** if the Liquid Depth is not an option.

Measure the distance from the bottom of the sensor to the zero flow point. Add 18.3 cm (7.2 in.) to the measured distance to obtain the total zero flow distance. Enter the total zero flow distance value into the application software.

### 6.2.3.4 Invisible Range/Deadband

**Note:** When programming the invisible range, 18.3 cm (7.2 in.) must be added to the desired range to compensate for the internal deadband distance between the sensor, the reflector, and the bottom of the sensor housing.

The 940 flow meter is equipped with an invisible range feature to prevent false echoes from top of channel walls, ladder rungs, shelves, etc. A user-selected range is defined that is invisible to the flow meter. Do not extend the invisible range to where it meets or overlaps the highest expected level in the channel.

Measure the distance between the bottom of the sensor housing and the object that is to be excluded from the level measurement. Add 18.3 cm (7.2 in.) to the measured distance to obtain the total invisible range (deadband) distance. Enter the total invisible range value into the application software.

### 6.2.4 Protecting the In-Pipe Ultrasonic Sensor

Keep the sensor and the reflector free of grease and dirt. Since the logger “listens” for the relatively faint sound of the returning echo, a heavily coated sensor will not be able to detect the echo well and may not provide accurate level measurement.

### 6.2.5 Troubleshooting the In-Pipe Sensor

During surcharged conditions, the ultrasonic level gives random depth readings that need to be edited in the application software.

Symptoms of this hydraulic condition occur when the level appears erratic within 5.7 cm (2.25 in.) of the pipe diameter. The readings first appear to be flat-lined. Later, the erratic readings (that in some cases exceed the pipe diameter) occur.

If the hydraulics are frequently in surcharge conditions, use a submerged level sensor instead of an in-pipe ultrasonic sensor.

### 6.3 Installing the Submerged Area/Velocity Sensor

Read the instructions carefully before installing the sensor. Failure to do so could result in serious injury to the operator or damage to the equipment.

#### 6.3.1 Zeroing the Submerged Area/Velocity Sensor

The sensor has been factory-calibrated and compensated for temperature. The sensor needs to be zeroed during each installation, but does not require calibration. The sensor should be zeroed when moving it from one flow meter or sample to another.

#### 6.3.2 Important Installation Guidelines for Submerged Area/Velocity Sensor

- Do not install more than one sensor at a time in pipes less than 61 cm (24 inches). Multiple sensors in smaller pipes can create turbulent or accelerated flows near the sensors that may cause inaccurate measurements.
- Mount the sensor as close as possible to the bottom of the pipe invert to accurately measure low velocity levels.
- Do not monitor flows in the invert of the manhole itself. The best sensor location is 3 to 5 times the sewer diameter/height upstream of the invert.
- Locate monitoring sites as far as possible from inflow junctions to avoid interference caused by combined flows.
- Avoid sites that contain flow obstacles within 2 to 4 pipe diameters in front of the sensor installation (rocks, stones, pipe joints, valve stems, etc.) as these contribute to turbulence and generate high speed flows in the immediate vicinity of the obstruction.
- Avoid any sites with slow moving flows that encourage the build-up of silt in the invert or channel. Excessive silting around the sensor may inhibit the Doppler signal and decrease sensor accuracy, and may affect depth measurement accuracy.
- Avoid sites with deep, rapid flows that make it physically difficult or dangerous to install the sensor.
- Avoid sites with high velocity, low-depth flows. Splash-over and excessive turbulence might be present around the sensor and data may be inaccurate.

### 6.3.2.1 Proper Strain Relief of Submerged Area/Velocity Sensor Cable

Attach the desiccant hub to the instrument handle to provide a strain relief for the sensor cable and connector (Figure 28).

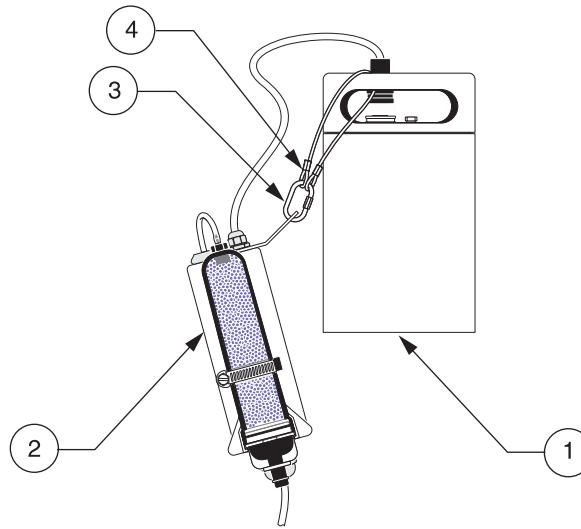

Figure 28 Proper Strain Relief

1	Flow Meter	3	Carabineer
2	Desiccant Hub	4	Lanyard

### 6.3.3 Connecting the Submerged Area/Velocity Sensor to the Mounting Bands

**Important Note:** If using an oil-filled sensor, replenish the oil prior to mounting the sensor to a mounting band. Refer to [section 7.8.3 on page 62](#) for oil replenishment instructions, if applicable.

1. Attach the sensor to the mounting band. Mounting bands come with pre-drilled holes for direct mounting of the sensor to the band.
2. Route the cable along the edge of the band and fasten the cable to the mounting band with nylon wire ties ([Figure 29 on page 54](#)) to reduce the likelihood of debris collecting on the cable and the mounting band. The cable should exit the tied area at, or near the top of the pipe to keep it out of the flow stream.

**Note:** If there is a large amount of silt at the bottom of the pipe, rotate the band until the sensor is out of the silt ([Figure 30 on page 54](#)), assuring that the sensor remains below the minimum expected water level at all times. The silt should not be disturbed and must be measured frequently.

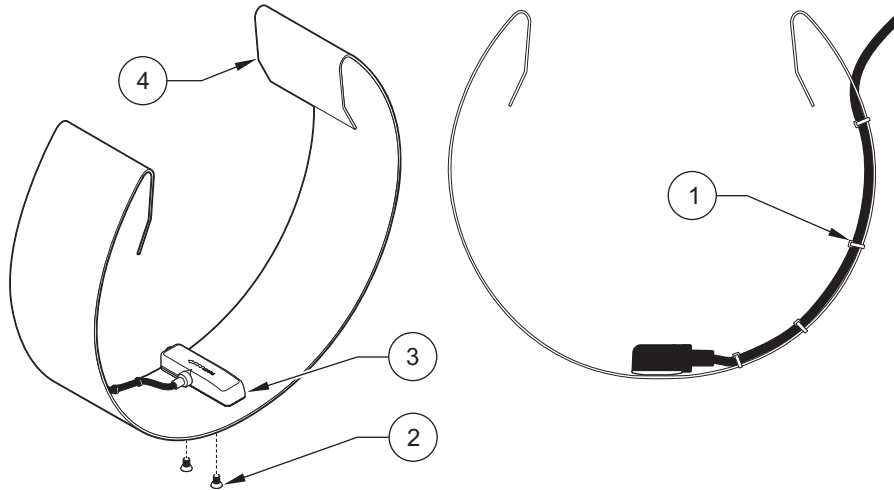

Figure 29 Attaching the Sensor to the Mounting Band

1	Nylon Wire Ties	3	Sensor
2	Screws (2)	4	Mounting band

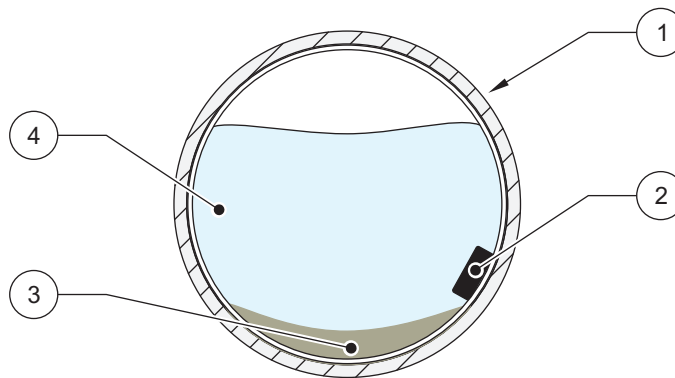

Figure 30 Avoiding Silt when Mounting the Sensor

1	Pipe	2	Sensor	3	Silt	4	Water
---	------	---	--------	---	------	---	-------

### 6.3.4 Placing the Submerged Area/Velocity Sensor and the Mounting Band into the Pipe

Point the angle-face of the sensor into the flow. The manufacturer recommends placing the sensor with the arrow pointing at the flow ([Figure 31 on page 55](#)). For other mounting configurations, see the appropriate flow meter manual.

Slide the mounting band as far as possible into the pipe to eliminate drawdown effects near the end of the pipe. Locate the sensor at the bottom-most point in the channel. If excessive silt is present on the bottom of the pipe, rotate the band in the pipe until the sensor is out of the silt.



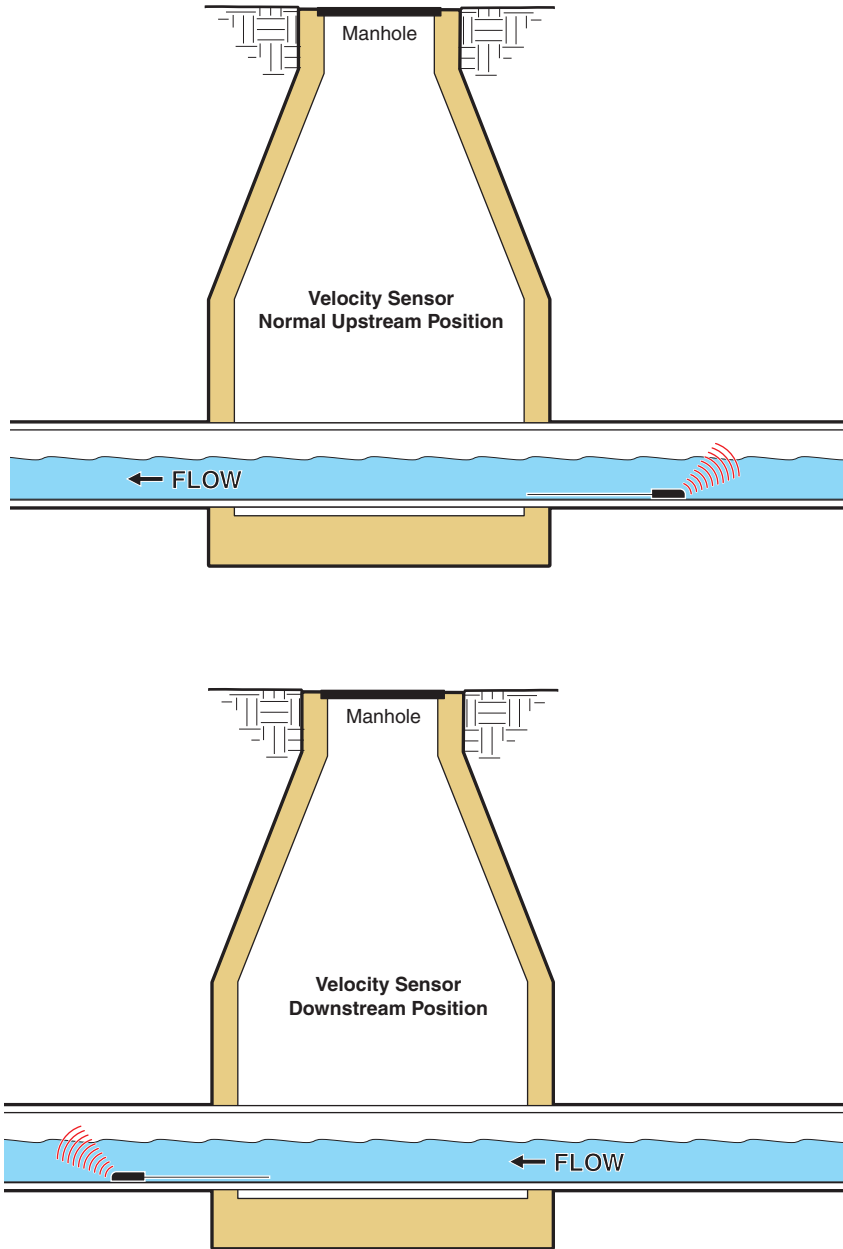

Figure 31 Placing the Sensor into the Flow



# Section 7 Maintenance

---

**DANGER**

*Only qualified personnel should conduct the tasks described in this section of the manual.*

**DANGER**

*Seul un technicien qualifié peut effectuer les tâches d'installation décrites dans cette section du manuel.*

**DANGER**

*All maintenance activities related to flow meter and flow meter accessories must be performed in a non-hazardous location.*

**DANGER**

*Toutes les opérations de maintenance relatives au débitmètre et à ses accessoires doivent être exécutées dans un environnement qui ne présente aucun danger.*

## 7.1 Maintaining the Battery Compartment Desiccant

The desiccant material is a silica gel indicator. When the gel is saturated with moisture, the beads turn from blue to pink. To rejuvenate the beads for reuse, remove them from the assembly. Heat the beads in an oven at 100 to 180 °C (212 to 350 °F) until the beads turn blue again. Discard and replace the beads if they do not turn blue after heating.

### 7.1.1 Replacing the Battery Compartment Desiccant

A small desiccant cartridge in the battery compartment ([Figure 17 on page 32](#) and [Figure 18 on page 32](#)) prevents moisture damage to the batteries and power circuitry. [Table 9](#) contains replacement part numbers.

If the normally blue desiccant beads turn pink, replace the cartridge or remove the cartridge end cap and recharge or replace the desiccant material.

A small clip holds the desiccant cartridge in place. Pull the cartridge straight out of the clip to remove it.

**Table 9 Replacement Desiccant**

Description	Part Number
Model 911 Battery Compartment Desiccant Cartridge	4933
Model 940 Battery Compartment Desiccant Cartridge	4967
Bulk Desiccant Refill (1.5 lb.)	3624

## 7.2 Maintaining the O-Ring Gasket on the End Cap

**Note:** Do not use petroleum jelly to lubricate the O-rings.

Two O-ring gaskets are installed in each flow meter end cap. The end caps maintain the water tight seal on the flow meter. Use care when the end caps are removed—do not soil, cut, or nick the gaskets. Replace them immediately if any physical damage is apparent. Use a light coating of O-ring lubricant to help maintain a water-tight seal. [Table 10 on page 57](#) lists replacement O-ring gaskets.

**Table 10 Replacement O-rings**

Description	Part Number
Model 911 End Cap O-ring (2 required)	4912
Model 940 End Cap O-ring (2 required)	4807

### 7.3 Cleaning the Flow Meters

Clean the outside of the logger case with warm water and mild detergent. Do not use solvents or harsh cleaners to clean the logger. Do not use high pressure washing equipment to clean the case.

### 7.4 Storing the Flow Meters

Remove all batteries from the logger when storing for long periods (more than 3 months). Store the sensors in a dry area. Make sure that all desiccant materials in the probes are kept fresh (blue) at all times.

### 7.5 Cleaning the Connectors

Coat connectors with lithium or di-electric grease to prevent corrosion.

### 7.6 Maintaining the Electronics Compartment

#### 7.6.1 Fuses

All internal fuses are self-resetting and require no maintenance. There are no other user-serviceable components inside the electronics compartment.

#### 7.6.2 Memory Batteries

An internal battery is provided to power RAM memory as well as the real time clock and associated circuitry. The memory battery keeps the programmed settings as well as the logged data whenever the main power fails or is removed during transport, storage, or replacement. The internal memory battery is located in the electronic compartment and is not user replaceable.

The internal memory battery has a life expectancy in excess of five years with the main battery installed. If the main battery is removed for an extended period of time, the life of the internal memory battery will be substantially shorter. The user can see a low memory battery indicator using the appropriate application software. See the software manual for details.

## 7.7 Replacing the Batteries in the RS232 Interface

**DANGER**

*Never replace batteries in a hazardous location.*

**DANGER**

*Ne jamais remplacer les piles dans une zone dangereuse.*

The Opto-Isolated RS232 interface uses a quantity of industrial quality Alkaline “C” cells. Under normal circumstances the batteries should last for more than 1,000 downloads based on an average download time of 5 minutes. The batteries need to be changed once a year due to the limited shelf life of any type of battery.

1. Remove the cover from the RS232 interface ([Figure 32](#)).
2. Remove the old batteries. Install fresh batteries into the RS232 interface, making certain the polarity is correct.

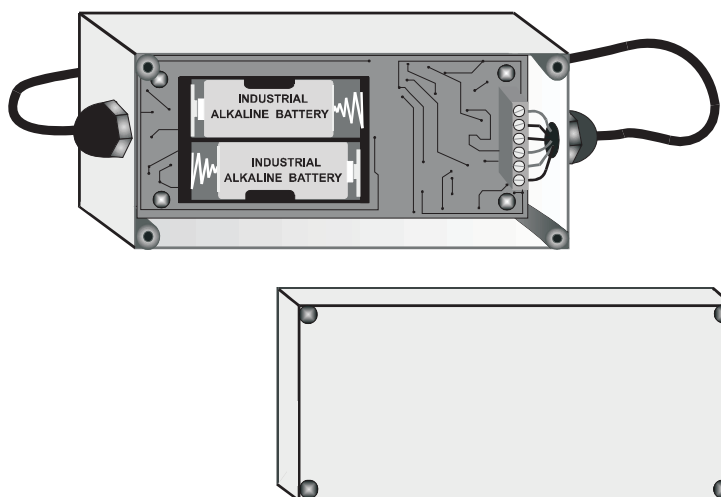

Figure 32 Replacing RS232 Batteries

## 7.8 Maintaining the Submerged Area/Velocity Sensor

### 7.8.1 Cleaning the Transducer Port

Clean the transducer port when:

- A drift in the readings is observed.
- Level data are missing or incorrect but velocity data are valid.
- Excessive silt has deposited between the transducer and its protective cover.

7.8.2 Cleaning the Submerged Area/Velocity Sensor (Oil-filled and Non-oil)

**Important Note:** DO NOT interchange an oil-filled protective cover plate with a non-oil cover plate. This adversely affects level readings. It is possible to convert one type of sensor to the other using the Oil Probe Conversion Kit (Cat. No. 7730000), refer to the Oil Probe Conversion Kit Instruction Sheet, Cat. No. 7730089 for more information.

**Important Note:** When cleaning the transducer, use the most gentle technique possible. Do not use sharp or pointed object to remove sediment from the face of the transducer. If the transducer is nicked or dented, it breaks!

1. Soak the sensor in soapy water

**Note:** Do not soak the sensor in bleach. Bleach permanently damages the sensor. Refer to [Table 11](#) for acceptable cleaning solutions.

2. Remove the screws from the protective cover ([Figure 33](#) and [Figure 34 on page 61](#)).
3. Remove the cover and gasket.
4. Swirl the sensor carefully in an appropriate cleaning solution to remove soil. Use a spray or squeeze bottle to wash away heavier deposits.
5. Clean the gasket and the cover. Replace the gasket (Cat. No. 7722000) if it is torn or damaged. Level readings are adversely affected if the gasket is damaged or not installed.
6. Reattach the gasket and the cover (note orientation in [Figure 34 on page 61](#)). Tighten the screws until the gasket starts to compress.
7. If using an oil-filled sensor, continue to follow the procedure mentioned in [section 7.8.3 on page 62](#).

**Table 11 Cleaning Solutions**

Acceptable	Unacceptable
Dish Detergent and Water	Concentrated Bleach
Window Cleaner	Kerosene
Isopropyl Alcohol	Gasoline
Dilute Acids	Aromatic Hydrocarbons

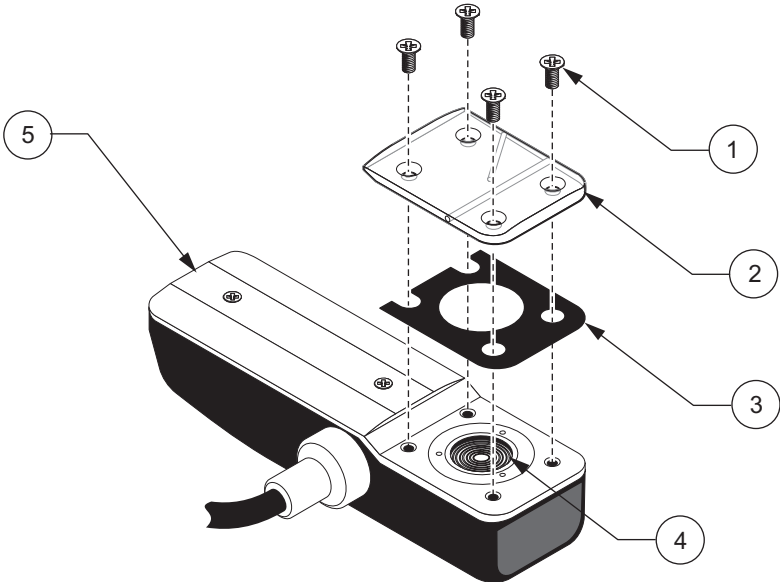

Figure 33 Removing the Protective Cover (Non-Oil Sensor)

1	Screws (#6-32 x 5/16)	4	Pressure Transducer
2	Protective Cover	5	Sensor
3	Gasket		

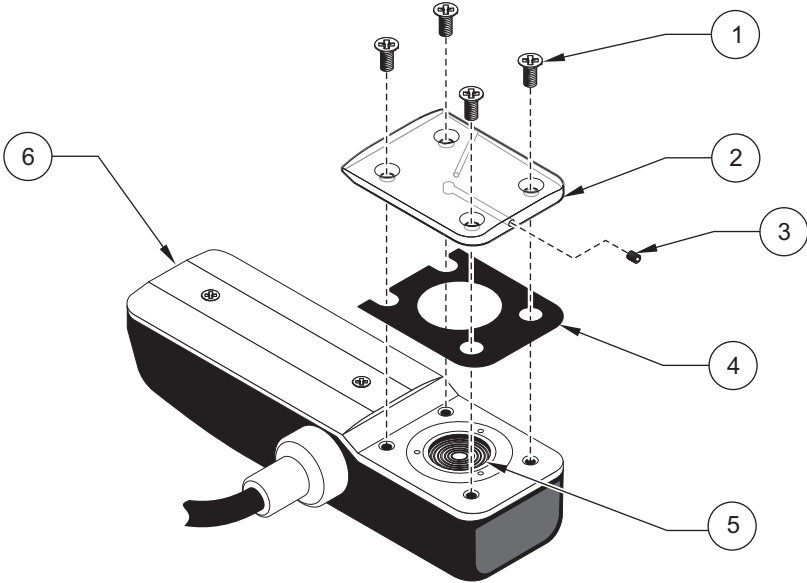

Figure 34 Removing the Protective Cover (Oil-filled Sensor)

1	Screws (#6-32 x 5/16)	4	Gasket
2	Protective Cover	5	Pressure Transducer
3	Screw, set, #2-56	6	Sensor

### 7.8.3 Replenishing the Oil

The manufacturer recommends inspecting the oil in the sensor for large air bubbles during the customer-scheduled service duty cycle, and prior to every installation. Small bubbles (less than 1/4-in. diameter) of air within the oil do not affect performance. Larger bubbles may minimize the anti-fouling benefit of the oil.

1. Remove the yellow tape on the sensor, if the sensor is new.
2. Remove any debris from the sensor.
3. Load the oil cartridge into the dispensing gun (Figure 35).
4. Twist the feed tube onto the cartridge and attach the syringe tip to the feed tube (Figure 36 on page 63).
5. Press the dispenser gun handle to purge any air bubbles from the syringe tip.
6. Remove the set screw in the transducer cover with the supplied 0.035 hex wrench. Retain the set screw.
7. Insert the syringe tip slowly into the set screw hole and dispense the oil (Figure 37 on page 63).

**Note:** While dispensing the oil, hold the probe at an angle to allow the air to be pushed out the side port (Figure 37 on page 63).

**Important Note:** Slowly insert the syringe tip and do not dispense oil during insertion or damage to the transducer may occur if too much pressure is applied. Continue to dispense the oil until all the air bubbles are removed.

8. Continue to dispense the oil while removing the syringe from the set screw hole to prevent air bubbles. Replace the set screw until it is flush with the transducer cover and remove any excess oil around the screw hole or on the sensor.
9. Clean the entire probe and place a piece of electrical tape over the side port to prevent oil from leaking out. Remove the tape from the sensor prior to zeroing and installing the sensor.

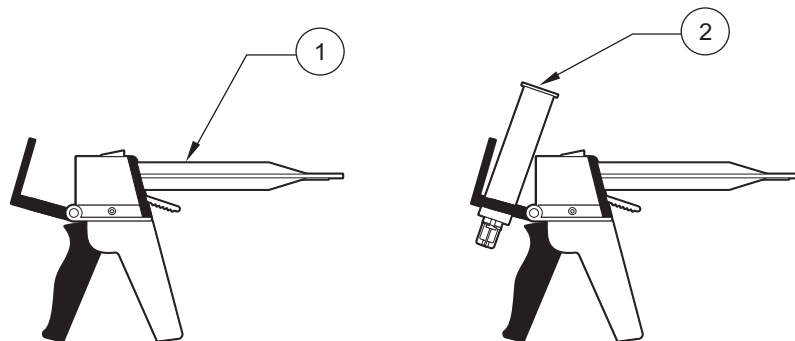

Figure 35 Loading the Cartridge into the Dispensing Gun

1 Dispensing Gun	2 Silicone Oil Cartridge
------------------	--------------------------



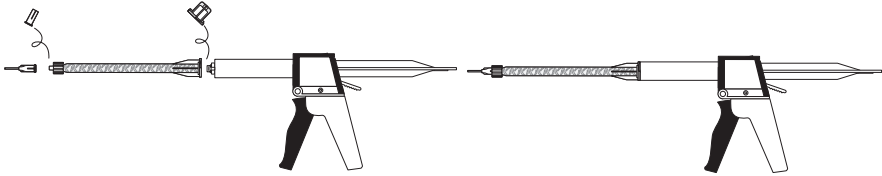

Figure 36 Attaching the Feed Tube and Syringe

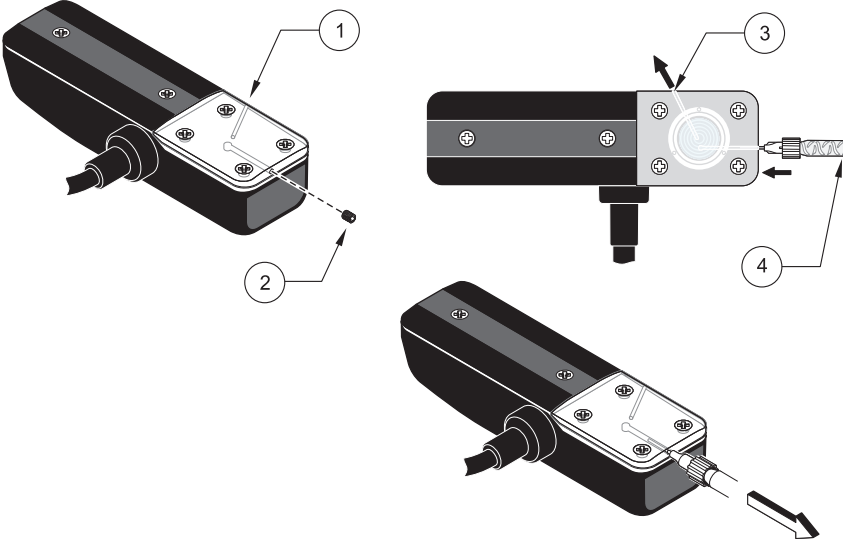

Figure 37 Oil Replenishment

1 Sensor	3 Side port
2 Set screw	4 Syringe

### 7.8.4 Changing the Submerged Area/Velocity Sensor Desiccant

The desiccant canister contains beads of silica gel which ensure proper orientation of the pressure transducer. When the beads are blue, they can remove moisture from the air. When they are pink, they are saturated and cannot absorb any more moisture from the air, and they must be replaced immediately.

**Important Note:** When the beads begin to turn pink, replace or recondition the beads. Permanent damage to the sensor may occur if the desiccant is not maintained. Never operate the sensor without the proper desiccant. When rejuvenating beads, remove them from the canister and heat at 100–180 °C (212–350 °F) until the beads turn blue. If the beads do not turn blue, replace them with new beads. Do not heat the canister.

### 7.8.5 Replacing the Desiccant

**Note:** Replacing the desiccant does not require that the desiccant container be removed from the desiccant box.

1. Twist the bottom end-cap using a slight twisting motion until its slots align with the retaining clips (Figure 38).
2. Remove the end cap gently by grasping it and pulling it straight out.
3. Pour the desiccant beads out of the canister.
4. Hold the canister up to the light and inspect the hydrophobic filter.
  - If there is a small, dim light spot while looking through the hole, the filter is in good condition. If there is a bright light spot, the filter is probably torn. Replace the filter.
  - If the desiccant beads are completely saturated with water or the filter has been saturated with water or grease, replace the filter.

**Note:** If the filter needs to be replaced, complete the Replacing the Hydrophobic Filter (section 7.8.5.1 on page 65), then continue with step 5.

5. Refill the canister tube with blue desiccant beads (Cat. No. 3624). Inspect the O-ring (Cat. No. 5252) on the bottom cap for cracks, pits, or evidences of leakage. Replace if necessary.

**Note:** Applying O-ring grease to the new or dry O-rings improves the ease of insertion, sealing, and life span of the O-ring.

6. Make sure that the O-ring is clean and free of dirt or debris before replacing the end cap.
7. Reinstall the end cap.

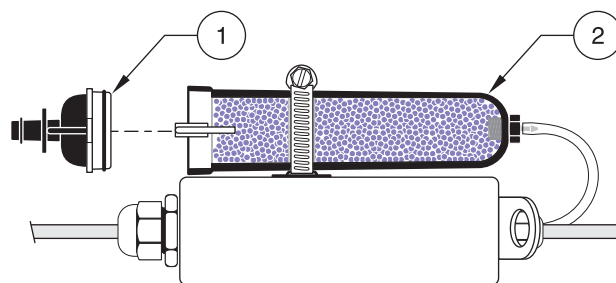

Figure 38 Removing the Bottom End Cap

1 End Cap	2 Desiccant Container
-----------	-----------------------

### 7.8.5.1 Replacing the Hydrophobic Filter

A single Teflon® hydrophobic filter (Cat. No. 3390) is installed in the top of the canister to prevent liquid from entering the vent tube.

For best performance and to avoid grease buildup on the filter during submergence or surcharge conditions, hang the canister vertically so that the end facing the sensor points downward.

1. Disconnect the tubing from the top of the desiccant canister.
2. Unscrew the hex-head tubing nipple from the top of the canister and discard the old filter.
3. Discard any remnants of Teflon tape from the nipple's threads. Reapply two turns of Teflon tape (Cat. No. 10851-45) to the threads, pulling the tape into the threads until it conforms to the shape of the threads.
4. Place a new filter over the hole. Make sure that the smooth side of the filter faces the inside of the canister.
5. Place the threaded nipple on top of the filter.
6. With a slight pressure, press the filter into the hole with the nipple threads and begin threading the nipple into the hole. The filter deflects upward and feed completely into the thread until it disappears. The filter must rotate with the nipple as it is threaded into the cap. If it does not, it is torn. Start over with a new filter.
7. Inspect the installation. A small, dim light spot should be visible in the upper cap when held up to the light. A bright spot indicates a torn filter. Start over with a new filter.

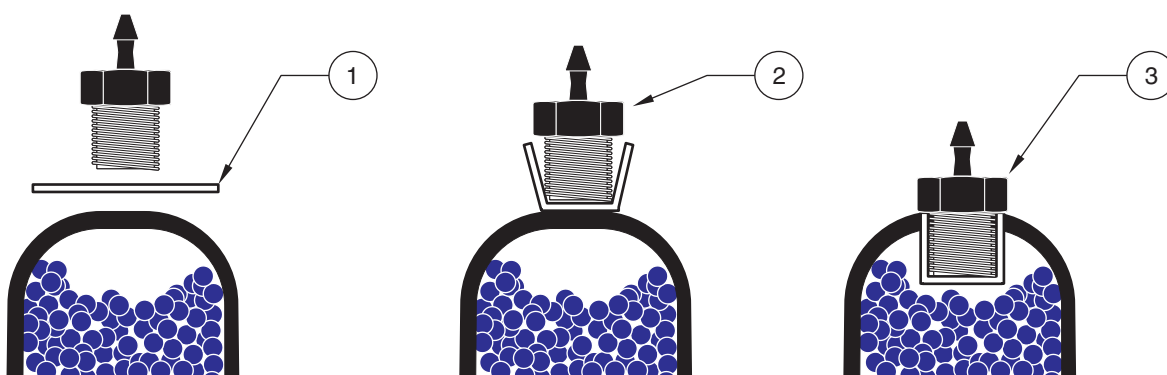

Figure 39 Replacing the Hydrophobic Filter

1	Filter, smooth side down	2	Hex-head tubing nipple	3	Finished assembly
---	--------------------------	---	------------------------	---	-------------------



# Section 8 Replacement Parts and Accessories

## 8.1 Flow Meter Replacement Parts

Description	Part Number
Battery, 12 AH (Model 911 only), rechargeable	5160-01
Charger, lead acid battery (Model 911 only)	913
RS232 Intrinsic Safety Barrier	4087
AC Power, 115 V with 2 AH battery backup and intrinsically safe barrier	1004
Battery pack, rechargeable, Lithium Ion (Model 940 only)	6608500
Charger, Lithium Ion battery pack (Model 940 only), 100-240 VAC, 50/60 Hz	6678000
Desiccant Cartridge for battery	4967
Ladder Mount, Ladder Rung-requires P/N 4839	4874
Ladder Mount, Mounting Bracket-requires P/N 4874	4839
Manhole Spanner Bars, 18-27 in., used with suspension cable	9542
Manhole Spanner Bars, 28-48 in., used with suspension cable	9557
Suspension cable for hanging flow meter	4920
User Manual	4979

## 8.2 Sensors

Description	Part Number
In-Pipe/Ultrasonic Level Sensor	4741
75 kHz Ultrasonic Sensor	5233-05
Submerged Area Velocity Sensors	
I.S. Oil-Filled Submerged AV Sensor, 0–10 ft range, 30 ft cable, with connector	88064-030
I.S. Oil-Filled Submerged AV Sensor, 0–10 ft range, 50 ft cable, with connector	88064-050
I.S. Oil-Filled Submerged AV Sensor, 0–10 ft range, 75 ft cable, with connector	88064-075
I.S. Oil-Filled Submerged AV Sensor, 0–10 ft range, 100 ft cable, with connector	88064-100
I.S. Oil-Filled Submerged AV Sensor, 0–30 ft range, 30 ft cable, with connector	88074-030
I.S. Oil-Filled Submerged AV Sensor, 0–30 ft range, 50 ft cable, with connector	88074-050
I.S. Oil-Filled Submerged AV Sensor, 0–30 ft range, 75 ft cable, with connector	88074-075
I.S. Oil-Filled Submerged AV Sensor, 0–30 ft range, 100 ft cable, with connector	88074-100
I.S. Standard Submerged AV Sensor, 0–10 ft range, 30 ft cable, with connector	88065-030
I.S. Standard Submerged AV Sensor, 0–10 ft range, 50 ft cable, with connector	88065-050
I.S. Standard Submerged AV Sensor, 0–10 ft range, 75 ft cable, with connector	88065-075
I.S. Standard Submerged AV Sensor, 0–10 ft range, 100 ft cable, with connector	88065-100
I.S. Standard Submerged AV Sensor, 0–30 ft range, 30 ft cable, with connector	88075-030
I.S. Standard Submerged AV Sensor, 0–30 ft range, 50 ft cable, with connector	88075-050
I.S. Standard Submerged AV Sensor, 0–30 ft range, 75 ft cable, with connector	88075-075
I.S. Standard Submerged AV Sensor, 0–30 ft range, 100 ft cable, with connector	88075-100

## 8.3 Sensor Mounting Rings and Bands

Description	Part Number
Submerged Pressure/Velocity Mounting Rings for 6–24 in. Pipes	
6 inches	1361
8 inches	1362

## Replacement Parts and Accessories

### 8.3 Sensor Mounting Rings and Bands (continued)

Description	Part Number
10 inches	1363
12 inches	1364
15 inches	1365
18 inches	1366
21 inches	1353
24 inches	1370
Submerged Pressure/Velocity Mounting Bands for 15 to 42 in. Pipes	
15 inches	9706100
18 inches	9706200
21 inches	9706300
24 inches	9706400
27 inches	9706500
30 inches	9706600
33 inches	9706700
36 inches	9706800
42 inches	9706900
15 to 42 inches	3766
In-Pipe Mounting Rings for 6 to 12 in. Pipes	
6 inches	4021
8 inches	4022
10 inches	4023
12 inches	4024
In-Pipe Sensor Mounting Bands for 15 to 42 in. Pipes	
15 inches	9706100
18 inches	9706200
21 inches	9706300
24 inches	9706400
24 inches	9706500
30 inches	9706600
33 inches	9706700
36 inches	9706800
42 inches	9706900
15 to 42 inches	3766

### 8.4 Ultrasonic Sensor Mounting Hardware

Description	Part Number
Permanent Wall Mount Bracket	2974
Adjustable for Floor or Wall	2904
Tripod w/ Mounting Bracket for Sensor	9538
Cable Straightener	2883
Cable Grip (Requires #2883)	3183

## 8.5 Mounting Plate Hardware for Directly Mounting to Pipe Wall

Sensor Type	Part Number
Submerged Pressure	4939
In-Pipe	3875





## Section 9 Contact Information

---

### Ordering information for the U.S.A.

**By Telephone:**  
(800) 368-2723

**By Fax:**  
301-874-8459

**By Mail:**  
Hach Company  
4539 Metropolitan Court  
Frederick, MD 21704-9452, U.S.A  
**Ordering information by e-mail:**  
hachflowsales@hach.com

### Information Required

- Hach account number (if available)
- Your name and phone number
- Purchase order number
- Brief description or model number
- Billing address
- Shipping address
- Catalog number
- Quantity

### Ordering Information for Outside the U.S.A. and Europe

Hach maintains a worldwide network of dealers and distributors. To locate the representative nearest you, send an e-mail to: hachflowsales@hach.com or visit [ww.hachflow.com](http://ww.hachflow.com).

### Technical Support

Technical and Customer Service Department personnel are eager to answer questions about our products and their use. In the U.S.A., call 1-800-635-1230. Outside the U.S.A. and Europe, send E-mail to hachflowservice@hach.com or call 1-301-874-5599.

### Repair Service

Authorization must be obtained from Hach Company before sending any items for repair.

To send the monitor to the factory for repair:

1. Identify the serial number of the monitor unit.
2. Record the reason for return.
3. Call the Customer Service Department (1-800-368-2723) and get a Service Request Number (SRN) and shipping label.
4. Use the shipping label provided and ship the equipment in the original packaging if possible.

**Note:** Do not ship manuals, computer cables, or other parts with the unit unless they are required for repair.

5. Make sure the equipment is free from foreign debris and is clean and dry before shipping. Sensors returned without cleaning will be charged a fee.
6. Write the SRN number on the shipping box.
7. Make sure that all return shipments are insured.
8. Address all shipments to:

Hach Company  
5600 Lindbergh Drive - North Dock  
Loveland, Colorado, 80539-0389 U.S.A.  
Attn: SRN#XXX

## Section 10 Contact information for Europe

---

For technical support, repair service and ordering information please refer to the contact information below.

**For all countries except France, Spain and Great Britain:**

Flow-Tronic  
RUE J.H. COOL 19a  
B-4840 Welkenraedt  
Belgium  
Ph: +-32-87-899797 or 899799  
Fx: +-32-87-899790  
Email: [info@flow-tronic.com](mailto:info@flow-tronic.com)  
[www.flow-tronic.com](http://www.flow-tronic.com)

For France, Spain and Great Britain:

**France**

HACH LANGE FRANCE S.A.S.33  
Rue du Ballon 93165 Noisy-le-Grand  
Telephone: ++33 (0)1 48 15 68 70  
Fax.: ++33 (0)1 48 15 80 00  
Email: [info@hach-lange.fr](mailto:info@hach-lange.fr)  
[www.hach-lange.fr](http://www.hach-lange.fr)

**Spain**

HACH LANGE, S.L.U  
C/ Larrauri, 1C, 2ª Pl.  
48160 Derio, Bizkaia  
Telephone: 902 131441 94 6573388  
Fax: 94 6573397  
E-mail: [info@hach-lange.es](mailto:info@hach-lange.es)  
[www.hach-lange.es](http://www.hach-lange.es)

**Great Britain:**

HACH LANGE LTD  
Pacific Way  
Salford  
Manchester  
M50 1DL  
Telephone: 0 161 872 1487  
Fax.: 0 161 872 7324  
Email: [sales@hach-lange.co.uk](mailto:sales@hach-lange.co.uk)  
[www.hach-lange.co.uk](http://www.hach-lange.co.uk)

## Section 11 Limited Warranty

---

Hach Company warrants its products to the original purchaser against any defects that are due to faulty material or workmanship for a period of one year from date of shipment unless otherwise noted in the product manual.

In the event that a defect is discovered during the warranty period, Hach Company agrees that, at its option, it will repair or replace the defective product or refund the purchase price excluding original shipping and handling charges. Any product repaired or replaced under this warranty will be warranted only for the remainder of the original product warranty period.

This warranty does not apply to consumable products such as chemical reagents; or consumable components of a product, such as, but not limited to, lamps and tubing.

Contact Hach Company or your distributor to initiate warranty support. Products may not be returned without authorization from Hach Company.

### Limitations

This warranty does not cover:

- Damage caused by acts of God, natural disaster, labor unrest, acts of war (declared or undeclared), terrorism, civil strife or acts of any governmental jurisdiction
- Damage caused by misuse, neglect, accident or improper application or installation
- Damage caused by any repair or attempted repair not authorized by Hach Company
- Any product not used in accordance with the instructions furnished by Hach Company
- Freight charges to return merchandise to Hach Company
- Freight charges on expedited or express shipment of warranted parts or product
- Travel fees associated with on-site warranty repair

This warranty contains the sole express warranty made by Hach Company in connection with its products. All implied warranties, including without limitation, the warranties of merchantability and fitness for a particular purpose, are expressly disclaimed.

Some states within the United States do not allow the disclaimer of implied warranties and if this is true in your state the above limitation may not apply to you. This warranty gives you specific rights, and you may also have other rights that vary from state to state.

This warranty constitutes the final, complete, and exclusive statement of warranty terms and no person is authorized to make any other warranties or representations on behalf of Hach Company.

### Limitation of Remedies

The remedies of repair, replacement or refund of purchase price as stated above are the exclusive remedies for the breach of this warranty. On the basis of strict liability or under any other legal theory, in no event shall Hach Company be liable for any incidental or consequential damages of any kind for breach of warranty or negligence.



# Appendix A Working with Primary Devices

---

## A.1 Working with Primary Devices and Sensor Operation

Installing the sensor in any primary device requires familiarity with the proper location for head measurement in that particular primary device. Just as the proper installation of the primary device itself is critical to obtaining optimum flow measurement accuracy, the appropriate location of the submerged or ultrasonic sensor also greatly affects flow measurement accuracy.

Always consult the manufacturer of the primary device, whenever possible, for details concerning the proper location of the sensor.

## A.2 Setting an Offset (For Use in a Weir)

When installing a submerged sensor behind a weir, the user may need to “offset” the actual reading from the submerged sensor to compensate for the difference in height between the submerged sensor and the crest of the weir. This allows the user to place the sensor at an arbitrary height in the weir, as long as it is located below the crest of the weir (and at the proper distance upstream from the weir plate). See [Figure 40 on page 76](#) for details on head measurement locations in a weir.

In the text example below:

- The distance between the crest of the weir (bottom of the ‘V’) and the submerged sensor is 4 in. (10 cm).
- The distance between the surface of the water and the submerged sensor is 6 in. (15 cm).
- The level of water which is contributing to flow is 2 in. (5 cm) (water flowing over the weir).

Entering 2 in. (5.1 cm) using the **LEVEL ADJUST** key provides the desired offset. As the water level falls to the bottom of the ‘V’ the flow meter reads zero level and zero flow. If the level falls below the crest of the weir, due to evaporation or other reason, the level reads a negative number and the flow remains at zero.

The key to proper level setting is to adjust the level (using the **LEVEL ADJUST** key) to the level that is contributing to flow. In a round pipe the level contributing to flow is the distance from the surface of the water to the invert (bottom) of the pipe. In a flume, the level contributing to flow is the distance from the surface of the water to the floor of the flume.

## A.3 Types of Primary Devices

Use the primary device illustrations that follow as general guides for proper head measurement location in commonly used primary devices. Refer to [Figure 41 on page 77](#) for Parshall Flume, [Figure 42 on page 78](#) for Palmer-Bowlus Flume (with Integral Approach), [Figure 43 on page 79](#) for Leopold-Lagco Flume, [Figure 44 on page 80](#) for H-Flume and [Figure 45 on page 80](#) for Round Pipes. Contact the primary device manufacturer for more details.

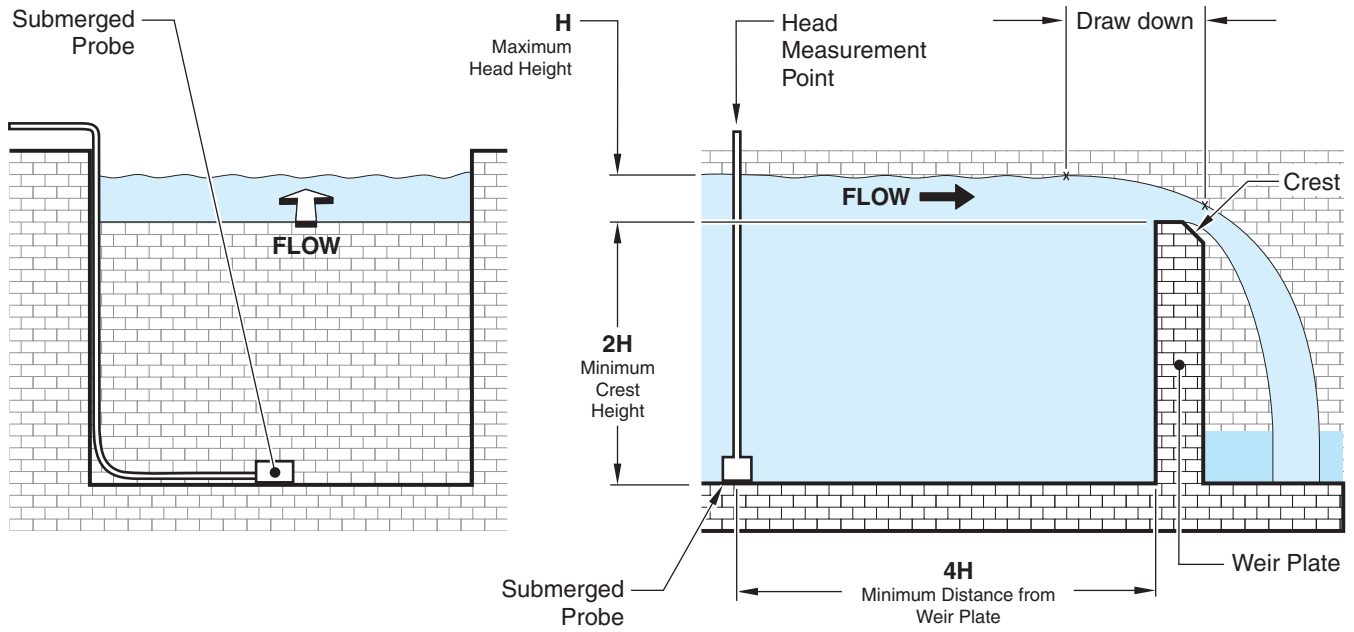

Figure 40 Weir

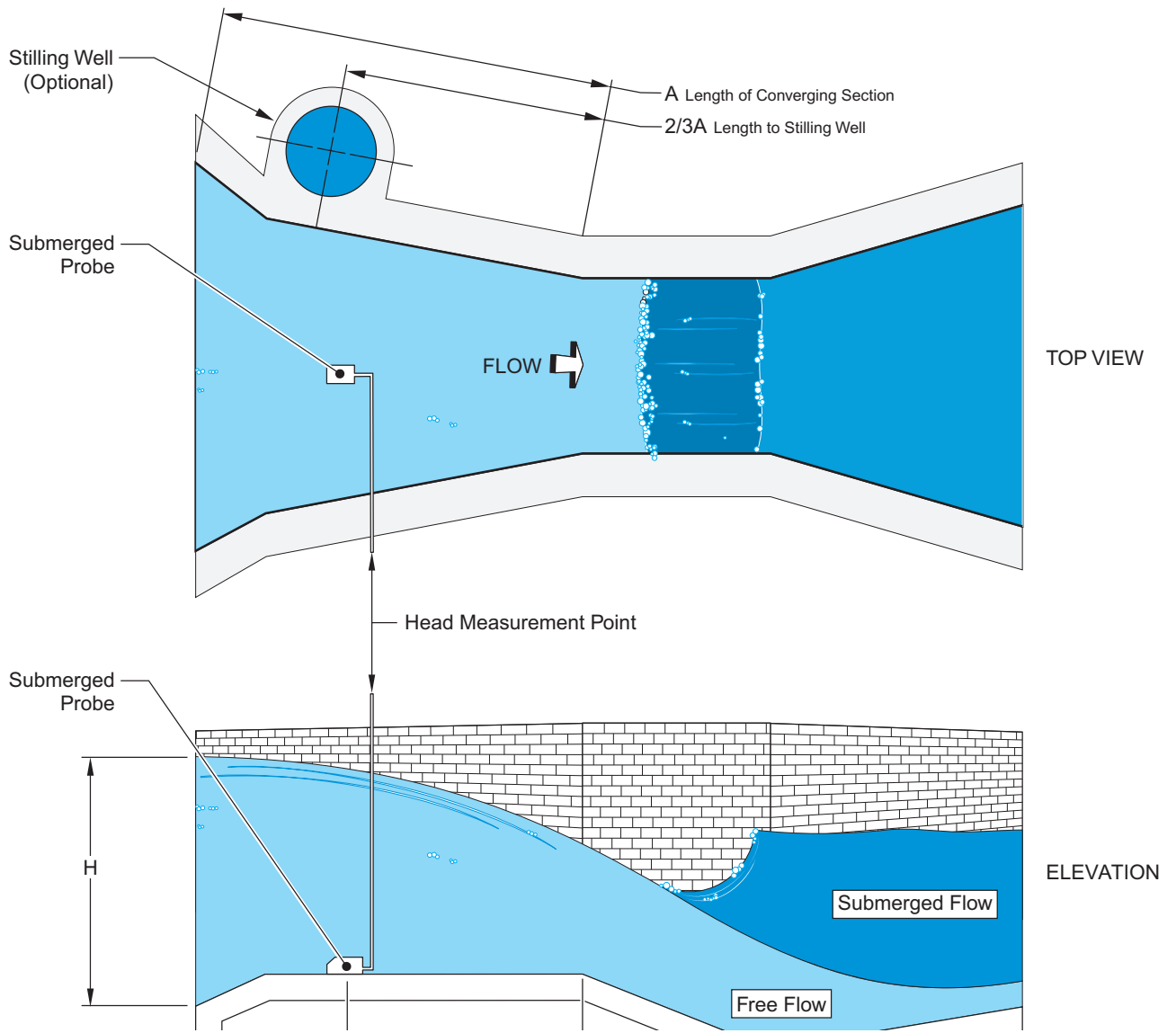

Figure 41 Parshall Flume

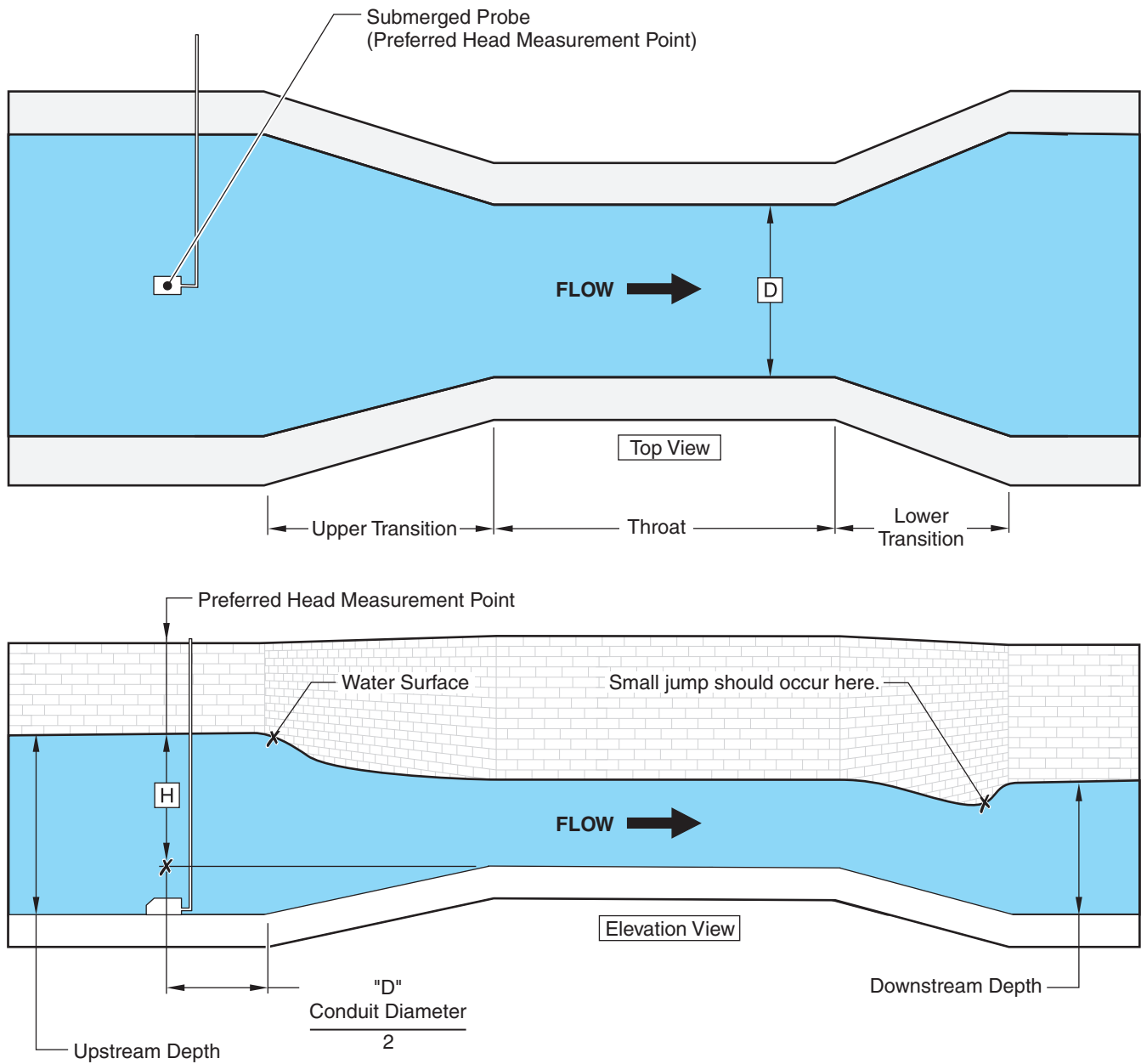

Figure 42 Palmer-Bowlus Flume (with Integral Approach)



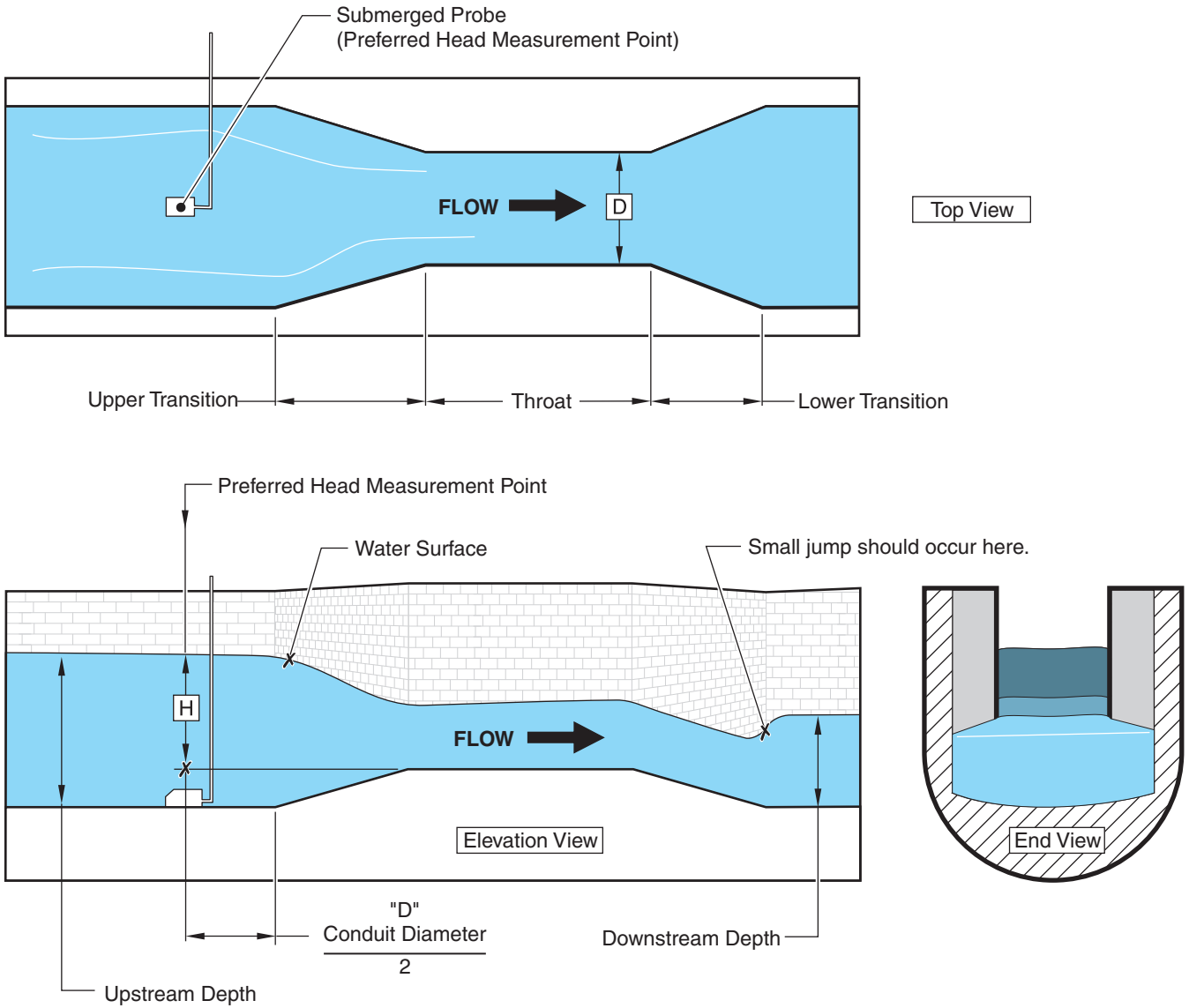

Figure 43 Leopold-Lagco Flume

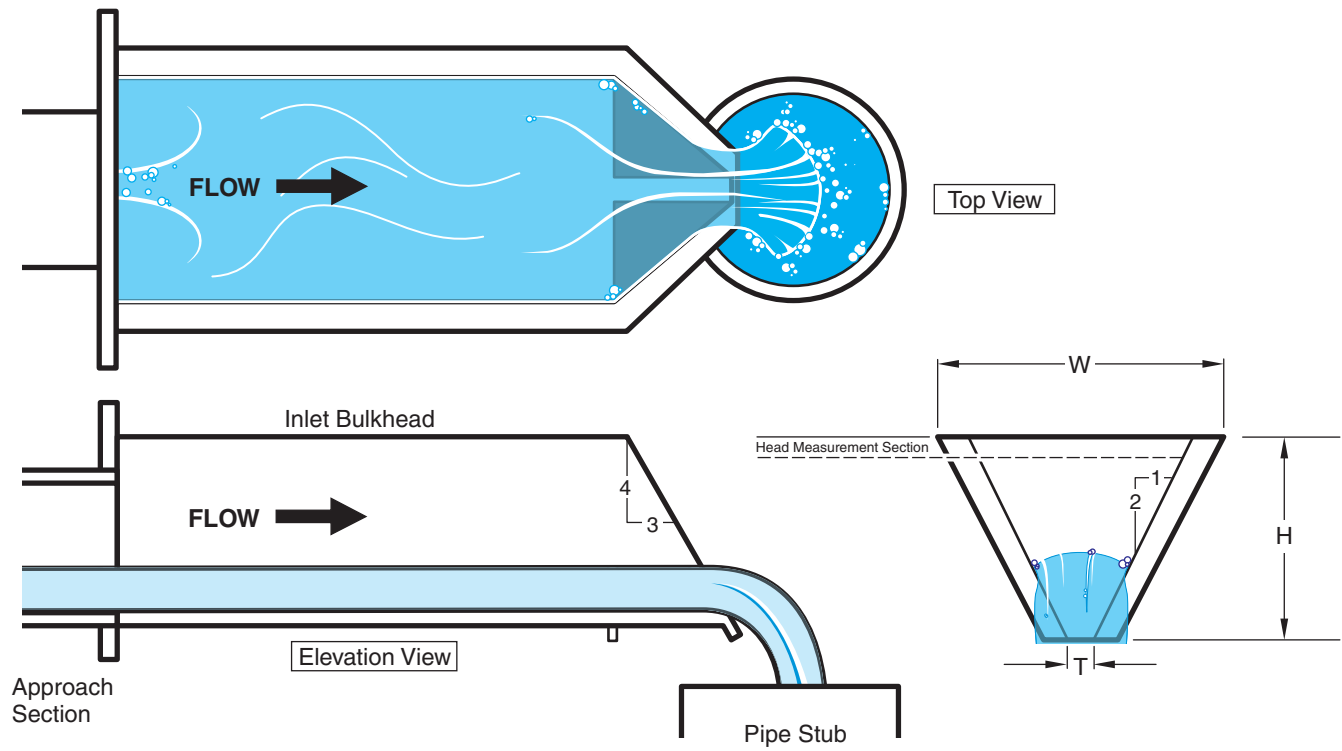

Figure 44 H-Flume

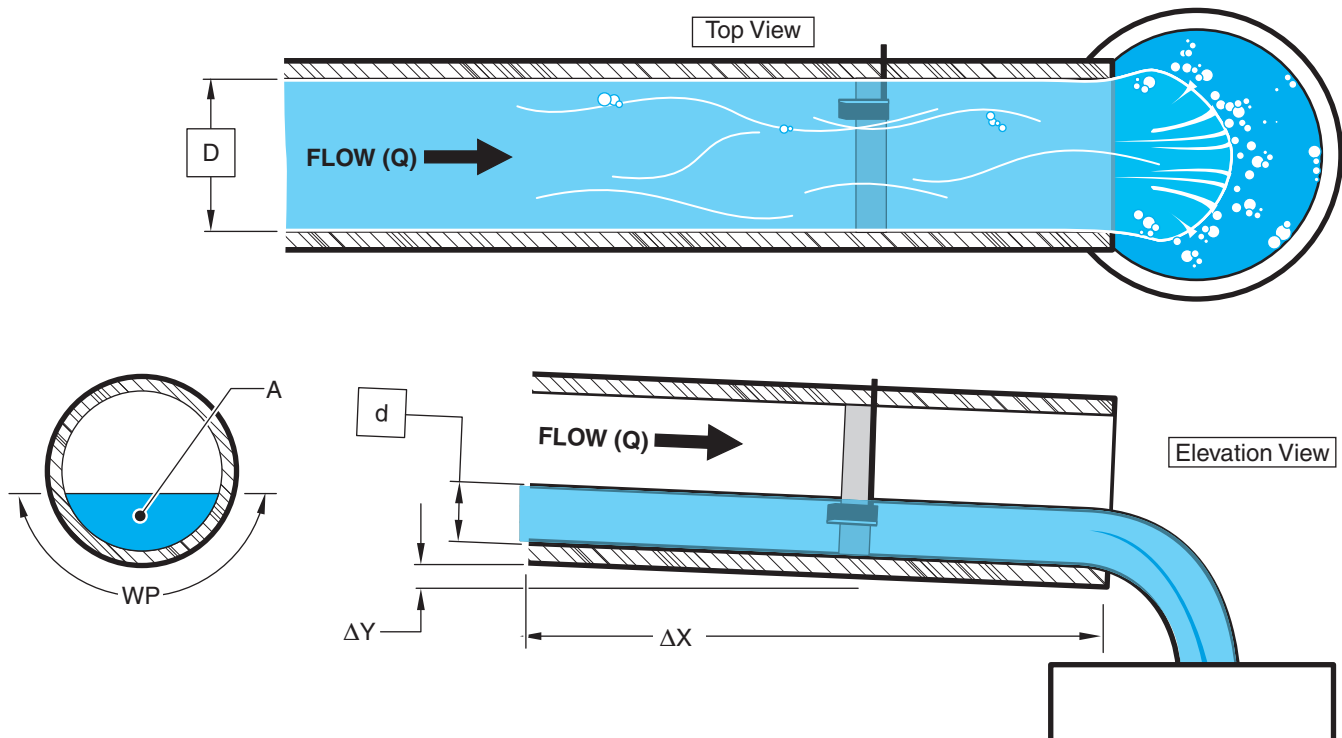

Figure 45 Round Pipes

## Appendix B Channel Installation Options

---

Figures 46 through 50 show how to install the 911 and 940 Flow Meters in various applications.

Figure 46 shows Model 911 installed in a manhole with a single level/velocity sensor stored in the small-diameter pipe.

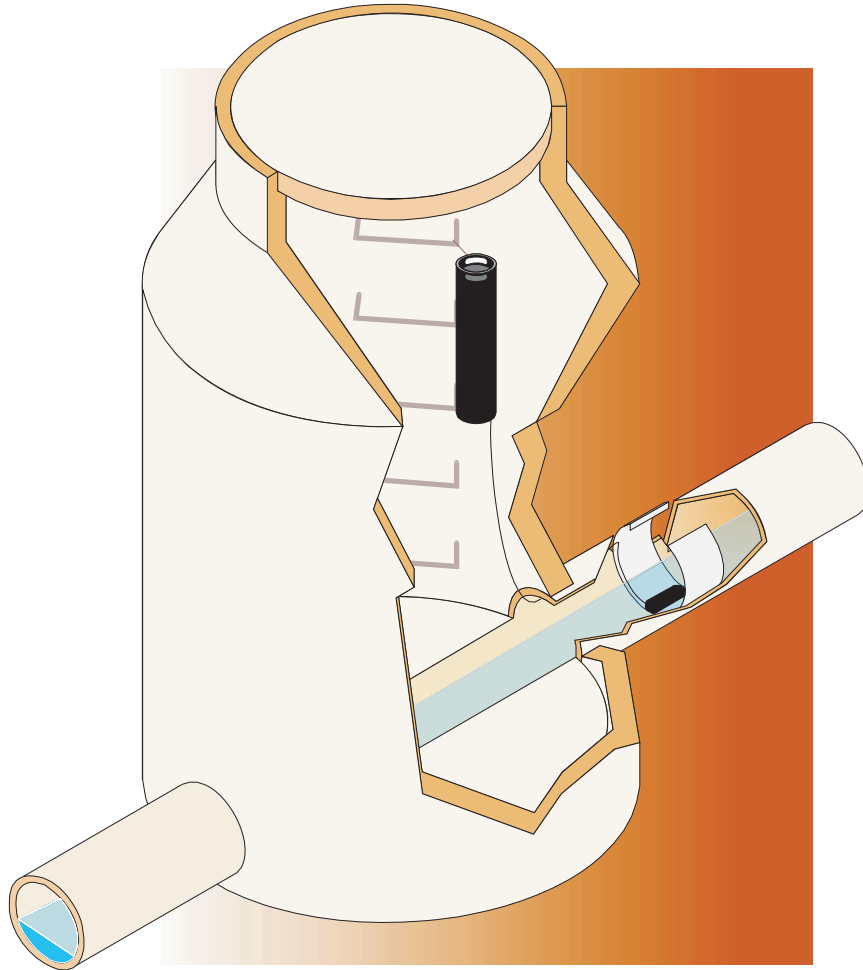

Figure 46 Small-Diameter Pipes Down to Street or Building Collectors

## Channel Installation Options

---

The 940 and the 911 Flow Meters do not require profiling to establish average velocity, allowing setup in a dry channel ([Figure 47](#)). Rapid signal processing and temperature compensation accurately record the change from dry to wet conditions.

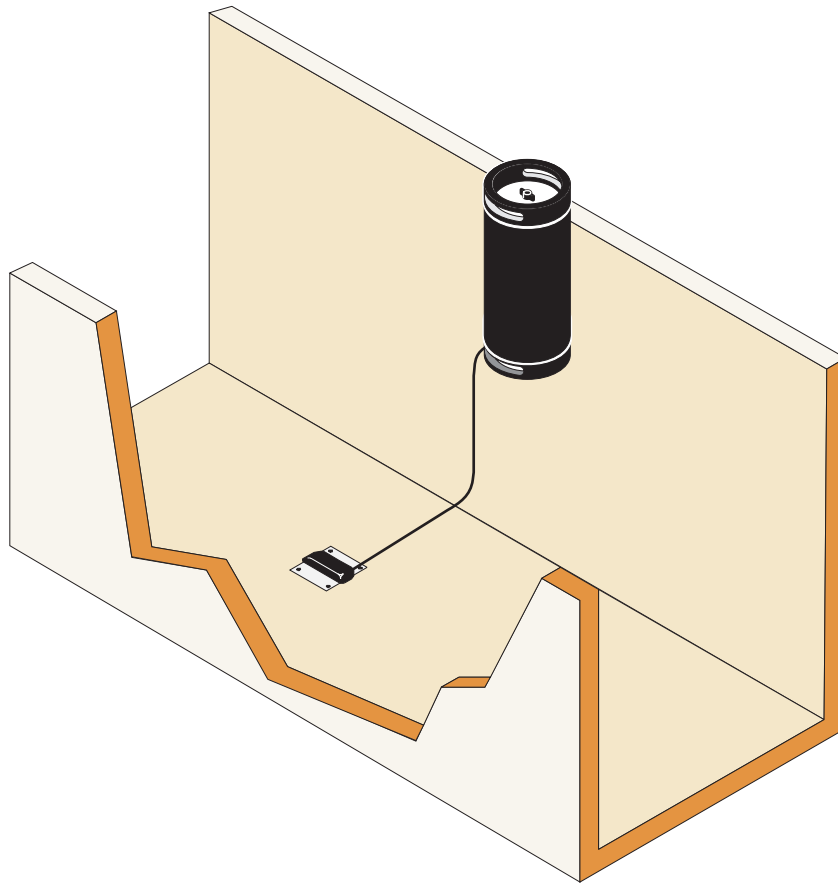

Figure 47 Installation Setup in a Dry Channel

Figure 48 shows a storm vault accepting flow from two locations. The 940 Flow Meter monitors level, velocity, and flow in both pipes and sends data via modem to a central location.

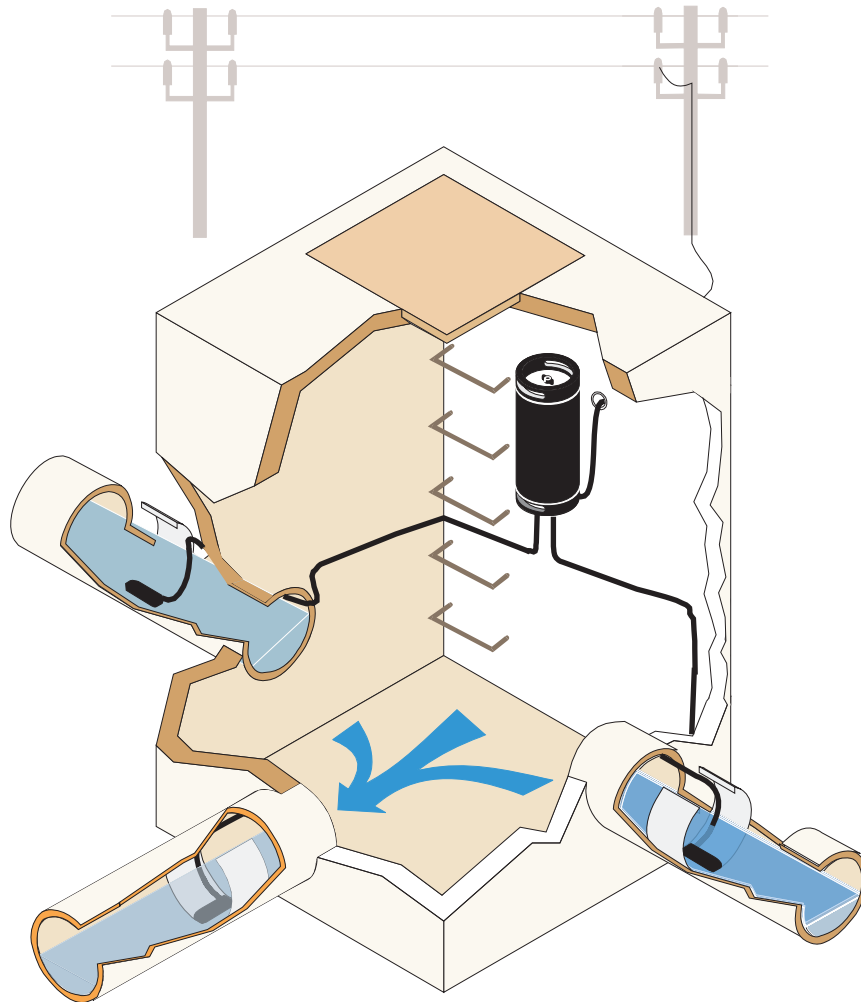

Figure 48 Installation for Multiple Source Monitoring at a Single Site

## Channel Installation Options

---

When a Combined Sewer Overflow (CSO) is conducive to accurate flow measurement, the 940 Flow Meter can measure depth and velocity in the primary channel and measure discharge in the overflow channel. See [Figure 49](#). In some instances, the overflow in some CSO applications may be too turbulent for accurate measurement.

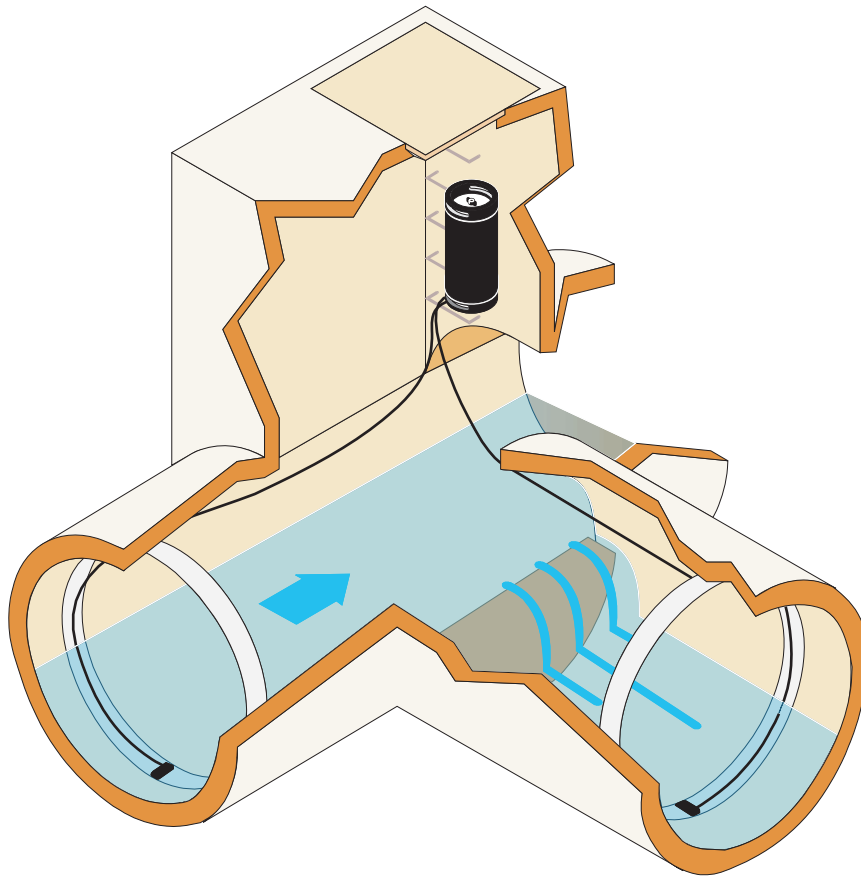

Figure 49 Installation for Combined Sewer Overflow (CSO) Applications

Custody transfer or interagency billing demand redundant measurement for chain of custody. In [Figure 50](#), the 940 Flow Meter provides ultrasonic measurement of flow in a Parshall flume while also measuring flow upstream using the Continuity Equation ( $Q=AV$ ). This ensures no loss of data in a submerged flow condition.

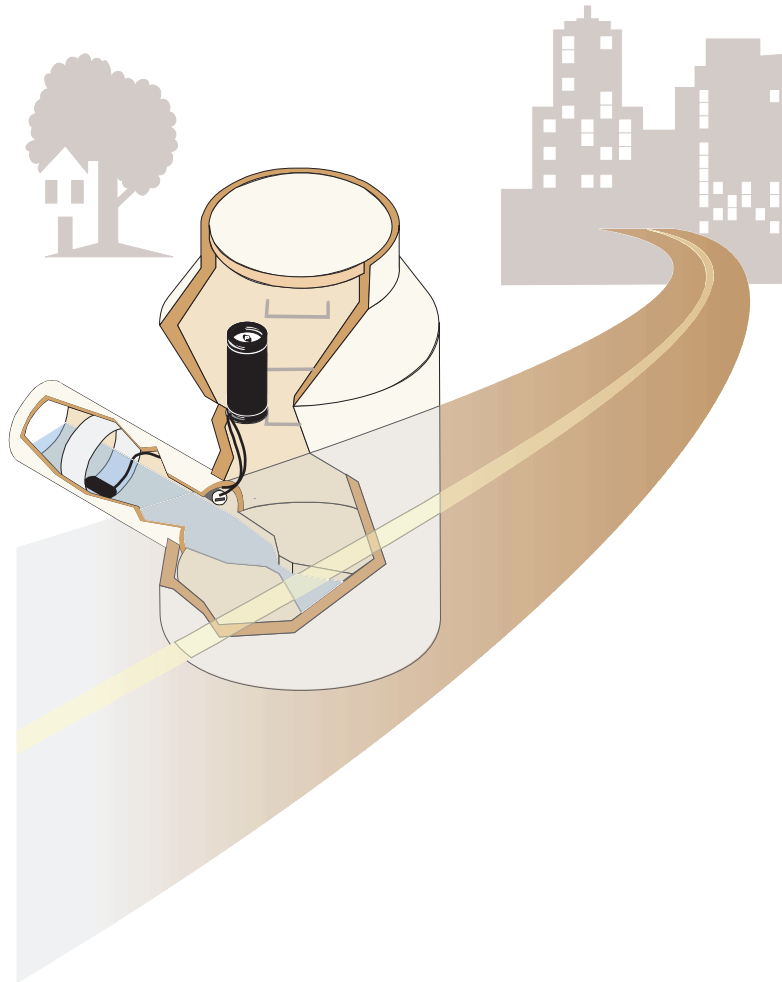

Figure 50 Installation for Custody Transfer or a Billing Arrangement





# Appendix C Batteries and Chargers

---

## **DANGER**

***Never install, remove or charge batteries in a hazardous location.***

## **DANGER**

***Vous ne devez jamais installer, retirer ou recharger les batteries dans un environnement dangereux.***

## **C.1 Lead-Acid (Gel Cell) Batteries for 911 Flow Meter**

The manufacturer's lead-acid batteries are designed to prevent electrolyte leakage from the terminals or case. The electrolyte is suspended in a gel, which ensures safe, efficient operation in any position. Gel cells are classified as "Non-Spillable" and meet all requirements of the International Air Transport Association.

### **Maintenance**

The manufacturer's lead-acid batteries are maintenance-free.

## **DANGER**

***The use of chargers other than those provided by the manufacturer for use with these batteries is not recommended and may damage the battery or shorten its life.***

## **DANGER**

***Il est déconseillé d'utiliser des chargeurs autres que ceux fournis par le fabricant pour ces batteries, car ils risquent de les endommager et de réduire leur vie utile.***

### **Charge**

The manufacturer's lead-acid cells are designed to be fully charged in 22 to 24 hours using their lead-acid battery charger. Do not exceed 24 hours or life of the battery may be damaged or shortened. The charge rate is 500 mA dc. The LED is lit, indicating the battery is charging. The battery is fully charged when the LED indicator turns off.

### **Temperature**

At higher temperatures, the electrical capacity that can be taken out of a battery increases. At lower temperatures, the electrical capacity that can be taken out of a battery decreases. However, excessive heat ruins batteries. Avoid placing batteries near heat sources of any kind. To maximize battery life, operate the battery at an ambient temperature of 20 °C (70 °F). The permissible operating temperature range is -15 to 50 °C (5 to 120 °F), however, use in the 5 to 35 °C (47 to 95 °F) temperature range is recommended.

### **Disposal**

- 911 Flow Meter: The battery pack assembly for the 911 Flow Meters are rechargeable/disposable. Follow local applicable disposal guidelines for gel–electrolyte type batteries. The entire battery housing is meant to be disposed of after the service life of the battery. Do not attempt to open the case to gain access to the batteries, there are no user serviceable parts inside.

### **Storage**

Store lead-acid batteries in a cool, dry place. Their low self-discharge rate and excellent charging characteristics permit storage for up to one year without loss of efficiency or appreciable deterioration of battery performance.

At room temperature the self-discharge rate of lead-acid batteries is approximately 3% of rated capacity per month. The self-discharge rate varies as a function of ambient storage temperature.

[Figure 51](#) shows the storage self-discharge characteristics of lead-acid batteries at various ambient temperatures. [Table 12](#) shows recommended storage times for lead-acid batteries.

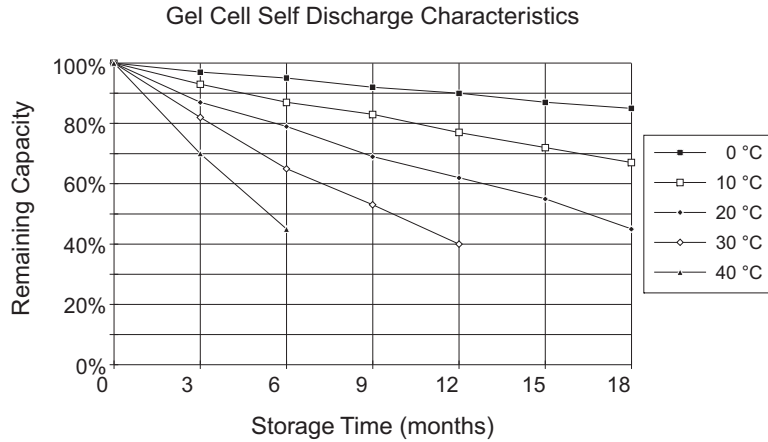

Figure 51 Battery Discharge Characteristics

Table 12 Lead-Acid Battery Storage Recommendations

Storage Temperature	Maximum Recommended Storage Time
0 to 20 °C	12 months
21 to 30 °C	9 months
31 to 40 °C	5 months
41 to 50 °C	2.5 months

## C.2 Rechargeable Lithium Ion Battery for 940 Flow Meter

A Lithium Ion rechargeable battery pack (6608500) is available for the 940 Flow Meter only. This is an alternative to the lead-acid and primary metallic Lithium (non-rechargeable) battery offered as an option for the 940 Flow Meter.

The Lithium Ion rechargeable battery pack is designed to allow up to 500 charge/discharge cycles and is shipped with a charger designed specifically for this battery pack. The Lithium Ion charger has specific plug wiring to prevent use with the primary non-rechargeable metallic Lithium pack or the lead-acid pack.

Do not attempt to use the Lithium Ion battery pack charger with the primary non-rechargeable metallic Lithium pack or the lead-acid pack. Do not attempt to use the lead-acid pack charger with the Lithium Ion battery pack.

### **DANGER**

*The use of chargers other than those provided by the manufacturer for use with these batteries is not recommended and may damage the battery or shorten battery life.*

### **DANGER**

*Il est déconseillé d'utiliser des chargeurs autres que ceux fournis par le fabricant pour ces batteries, car ils risquent de les endommager et de réduire leur vie utile.*

### **Maintenance**

This battery pack requires no maintenance other than charging.

### **Charge**

Inspect the Lithium Ion battery pack and the battery connection for damage before use or charging. Do not attempt to use or repair a damaged battery pack assembly.

Use only the charger provided for the Lithium Ion pack (6678000). The pack can be recharged at any time regardless of charge level. Total discharge will have a negative impact on the number of charge/recharge cycles allowable and should be avoided. The Lithium Ion battery can be fully charged in 8 to 12 hours using the charger provided. The charger will terminate the charge automatically and float-charge the battery until it is removed from the charger. The charge rate is 600 mA DC.

When the charger is plugged into a suitable AC voltage source the power LED will illuminate. When the battery pack is connected the charge LED will illuminate yellow. A flashing yellow charge LED indicates that the battery is deeply discharged but the charge cycle is starting. If the flashing yellow charge LED does not stop flashing within 1 hour the battery pack is shorted and should be disposed of properly. The battery is fully charged when the yellow charge LED light goes off.

### **Temperature**

Excessive heat ruins batteries. At higher temperatures, the electrical capacity that can be taken out of a battery increases. At lower temperatures, the electrical capacity that can be taken out of a battery decreases. Avoid placing batteries near heat sources of any kind. To maximize battery life, operate the battery at an ambient temperature of 20 °C (70 °F). The permissible operating temperature range is -15 to 50 °C (5 to 120 °F). Use in the 5 to 35 °C (47 to 95 °F) temperature range is recommended.

### **Disposal**

The Lithium Ion battery pack assembly for the 940 Flow Meter is rechargeable. Follow local applicable disposal guidelines for Lithium Ion type batteries. The entire battery housing is meant to be disposed of after the service life of the battery. Do not attempt to open the case to gain access to the batteries. There are no user serviceable parts inside.

### **Batteries and Chargers**

The 940 Flow Meter may use two different types of Lithium-based battery. These batteries require special disposal requirements and must be treated as hazardous material. Air cargo is the only acceptable air shipment permitted. The batteries must be individually wrapped and boxed separately. Do not puncture, incinerate or expose to water. If local government does not allow for the disposal of these batteries contact the Hach Company for proper disposal arrangements.

### **Storage**

Store all battery types in a cool, dry place. A low self-discharge rate and excellent charging characteristics permit storage of Lithium Ion batteries for up to one year without loss of efficiency or appreciable deterioration of performance. At room temperature the self-discharge rate of Lithium Ion batteries is approximately 1% of rated capacity per month.



# Appendix D SCADA-Modbus® System Guidelines

## D.1 Introduction to SCADA - Modbus Communications

Use this section as a guide when using the Modbus ASCII protocol to communicate directly with the 940 Flow Meter via an RS232 or modem connection.

This guide assumes that the user has a working knowledge of Supervisory Control and Data Acquisition (SCADA), its components, and the different topologies used to construct the communications network. Because a basic understanding of the Modbus ASCII protocol is necessary, the key pieces of the protocol will be described.

This section guides the users through the setup process by describing key points that need to be addressed for successful communication. This section will not outline specific implementation details of any particular Man Machine Interface (MMI) or controller, although examples may reference certain manufacturers for illustrative purposes. The description of the Modbus ASCII protocol is provided for reference only and is not intended as a tutorial. The scope of this section is limited to the description of Modbus ASCII as it pertains to the 940 Flow Meter.

Modbus, an open protocol, determines how each instrument knows its device address, recognize a message addressed to it, determine the type of action to be taken, and extract any data or other information contained in the message. The flow meter and Man Machine Interface (MMI) communicate using a master-slave technique in which only the master can initiate queries to a slave (940). The 940 is always considered the slave, never a master. The master can address individual 940 Flow Meters or can broadcast a message to instruments within its scope. Responses are never returned to broadcast queries from the master. The Modbus protocol establishes the format for the master's query by placing into it the device address, a function code defining the requested action, any data to be sent, and an error-checking field. The flow meter's response message is constructed using the Modbus format which confirms the action to be taken, any data to be returned, and an error checking field.

## D.2 ASCII Transmission Mode

The 940 Flow Meter is designed to communicate on standard Modbus networks using Modbus ASCII. In ASCII mode, messages start with a colon ':', and end with a 'carriage return-line feed' pair. The allowable characters transmitted for all fields are hexadecimal 0–9, and A–F. When a message is transmitted over a Modbus ASCII communication link, each character or byte is sent in the order of Least Significant Bit to Most Significant Bit. A typical message frame looks like the following:

START	ADDRESS (HEX)	FUNCTION (HEX)	DATA (HEX)	LRC (HEX)	END (HEX)
1 Char ':'	2 Chars	2 Chars	n Chars	2 Chars	2 Chars 'CRLF'

## D.3 Address Field

The address field of an ASCII message frame, ranging from 0 to 247 decimals, consists of two characters that represent the slave address. Individual slaves are assigned values between 1 and 247. A master addresses a slave by putting the slave's address in the address field of the message frame. When the slave sends its response, it places its own address in the address field of the message frame to let the master know which slave is responding.

### D.4 Function Field

The function code field of an ASCII message frame, ranging from 1 to 255 decimals, consists of two characters that represent the type of action the master is requesting from the slave. Of these functions, the 940 Flow Meter currently supports function 3 (Read Holding Registers). When a message is sent from the master to a slave device, the function field tells the slave what kind of action to perform. For example, this may include reading the channel values of Level and Velocity. When the slave responds to the master, it echoes the function code field to indicate a normal response. In the event of an error, such as parity error, LRC error, or a request that cannot be handled, the slave will not respond and the master will eventually process a time-out condition.

### D.5 Data Field

The data field of an ASCII message frame consists of  $n$  pairs of ASCII characters that represent data sent to or from a slave device (flow meter). The data field contained in the master request contains additional information that is required by the slave before any action takes place. This may include channel register addresses, the number of registers to read, and the actual byte count in the data field. For example, if a master requests that the flow meter read the current status of a group of channels (function code 03), the data field specifies the starting register and how many registers are to be read. If no error occurs, the data field of the response from the meter to the master contains the data requested.

### D.6 LRC Field

The LRC field of an ASCII message frame consists of two ASCII characters that provide an additional level of error checking to verify the integrity of the communication media. The LRC field is one byte that contains an 8-bit binary value. The LRC value is calculated by the transmitting device, which appends the LRC to the end of the message. The receiving device recalculates the LRC and compares it against the LRC value of the incoming message. If the two values are not equal, an error condition occurs. The LRC is calculated by adding together successive 8-bit bytes of the message, discarding any carries, and then complementing the result. The LRC is calculated by summing all values in the ASCII message except for the leading 'colon' and ending <CR><LF>.

### D.7 Communication Parameters

To successfully communicate with the 940 Flow Meter using Modbus ASCII, the communication parameters of the master device must be set at 7 bits, Even Parity, and 1 Stop bit. The baud rate may be configured to any value offered by the 940 Flow Meter. With the exception of baud rate, the communication parameters must not vary from this format.

### D.8 User Memory Customizing

The most familiar component of existing SCADA networks today is the Programmable Logic Controller (PLC). Because the network integrator is most familiar with this type of device, the flow meter emulation of an existing PLC simplifies the process of integrating the manufacture's instrumentation into the SCADA network. Modbus ASCII uses a referencing system to identify the various types of memory inputs and outputs. Each reference number has a leading digit that identifies its data type (discrete input, discrete output, register input, register output) followed by a string of digits that indicates its location in RAM ([Table 13](#)).

**Table 13 Modbus ASCII Memory Input/Output Referencing System**

Reference Indicator	Reference Type	Meaning
0xxxx	Discrete Output or Coil	Binary
1xxxx	Discrete Input	Binary
3xxxx	Input Register	Real
4xxxx	Output Holding Register	Real
6xxxx	Extended Memory Register	Real

The memory data is stored in 16-bit words. Within the predefined function codes of the Modbus ASCII protocol, the data fields are subject to interpretation by the device manufacturer. For example, the 940 Flow Meter places temperature information in registers 40001-40002.

## D.9 Modbus ASCII Function Codes Supported

Currently, the 940 Flow Meter is capable of a read-only function to retrieve channel and total flow information. All data addresses in the Modbus ASCII message are referenced to zero. Therefore, a reference to holding register 40001 is addressed as register 0000. The function code field specifies the type of register accessed; therefore, the 4XXXX is implicit.

### Function 03: Read Holding Registers

Reads the register (4X reference) contents of the 940 Flow Meter as defined in the tables that follow.

**Table 14 Channels' Read Holding Register Addresses**

Name	Type	Size (bits)	# of Registers	Start Address Hi	Start Address Lo	Registers
Temperature	Float	32	2	00	00	40001-40002
Rainfall	Float	32	2	00	02	40003-40004
pH (or ORP)	Float	32	2	00	04	40005-40006
Level 1	Float	32	2	00	06	40007-40008
Velocity 1	Float	32	2	00	08	40009-40010
Channel 1	Float	32	2	00	0A	40011-40012
Channel 2	Float	32	2	00	0C	40013-40014
Channel 3	Float	32	2	00	0E	40015-40016
Channel 4 (D.O.)	Float	32	2	00	10	40017-40018
Channel 5 (D.O. Temp.)	Float	32	2	00	12	40019-40020
Channel 6 (Conductivity)	Float	32	2	00	14	40021-40022
Channel 7 (Cond. Temp.)	Float	32	2	00	16	40023-40024
Level 2	Float	32	2	00	18	40025-40026
Velocity 2	Float	32	2	00	1A	40027-40028
Flow 1	Float	32	2	00	20	40033-40034
Power	Float	32	2	00	26	40039-40040

Table 15 Channels' Units of Measure Read Holding Register Addresses<sup>1</sup>

Name	Type	Size (bits)	# of Registers	Start Address Hi	Start Address Lo	Registers
Temperature	Integer	16	1	00	31	40050
Rainfall	Integer	16	1	00	32	40051
pH (or ORP)	Integer	16	1	00	33	40052
Level 1	Integer	16	1	00	34	40053
Velocity 1	Integer	16	1	00	35	40054
Channel 1	Integer	16	1	00	36	40055
Channel 2	Integer	16	1	00	37	40056
Channel 3	Integer	16	1	00	38	40057
Channel 4 (D.O.)	Integer	16	1	00	39	40058
Channel 5 (D.O. Temp.)	Integer	16	1	00	3A	40059
Channel 6 (Conductivity)	Integer	16	1	00	3B	40060
Channel 7 (Cond. Temp.)	Integer	16	1	00	3C	40061
Level 2	Integer	16	1	00	3C	40061
Velocity 2	Integer	16	1	00	3E	40063
Flow 1	Integer	16	1	00	41	40066

<sup>1</sup> The addresses shown above return a code that represents the appropriate unit of measure.

Table 16 Flow Totalizer Read Holding Register Addresses

Name	Type	Size (bits)	# of Registers	Start Address Hi	Start Address Lo	Registers
Total Flow 1	Float	32	2	00	4A	40075-40076
Total Flow Units	Integer	16	1	00	50	40081
Total Flow Multiplier	Float	32	2	00	51	40083-40084

Table 17 SCADA-Modbus Units of Measure Codes

Unit	Code	Unit	Code
ML	1	GPH	26
AF	2	LPS	27
CF	3	LPM	28
GAL	4	LPH	29
L	5	MGD	30
M3	6	PH	31
IN	7	ORP	32
CM	8	PPM	33
FT	9	PPB	34
M	10	MGL	35
CM2	11	PCTSAT	36
FT2	12	MSIEMENS	37
IN2	13	MICROSIEMENS	38
M2	14	GRAMSPERKG	39
AFD	15	PCTPERDEGC	40
CFS	16	DEGREE_C	41



Table 17 SCADA-Modbus Units of Measure Codes

Unit	Code	Unit	Code
CFM	17	DEGREE_F	42
CFH	18	MILS	43
CFD	19	VOLTS	44
CMS	20	FPS	45
CMM	21	MPS	46
CMH	22	PCT_O2	47
CMD	23	PCT_H2S	48
GPS	24	PCT_LEL	49
GPM	25	VDC	50

## D.10 Query

The Modbus ASCII query must take the form shown below that specifies the starting register and number of registers to be read:

Start “:”	Slave Address	Function (03)	Start Address High	Start Address Low	No. of Pts. High	No. of. Pts. Low	LRC	<CR>	<LF>
--------------	------------------	------------------	--------------------------	-------------------------	---------------------	---------------------	-----	------	------

For example, to read the level channel of the 940 Flow Meter, the query must be as indicated in [Table 18](#).

Table 18 Channel Query to Read Level (Example)

Start	“:”
Slave Address	01
Function	03
Starting Address High	00
Starting Address Low	06
No. of Registers High	00
No. of Registers Low	02
LRC	F4
Stop	<CR><LF>

The master queries the flow meter using a Read Holding Registers request, which implies a 4XXXX register reference, to slave device address 01. The message requests data from holding registers 40007–40008 to obtain the level information, which requires two registers to store the floating point value. Note that registers are referenced from zero in the data field.

## D.11 Response

The 940 Flow Meter responds with the following transmission reflecting a level reading of 15.0 inches:

**Table 19 Transmission Response that Reflects a 15 in. Level Reading**

Start	'
Slave Address	01
Function	03
Byte Count	04
Data High	00
Data Low	00
Data High	41
Data Low	70
LRC	47
Stop	<CR><LF>

The flow meter response echoes the address and function code, which indicates that no problems exist in the communication between the master and 940. The 'Byte Count' field specifies how many 8-bit data items are being returned in the data field. With Modbus ASCII, this is one-half the actual count of ASCII characters transmitted in the data portion of the response. The contents of 40007 are shown as two byte values of 00 00 hex, and the contents of register 40008 are shown as two byte values 41 70 hex. Together, these values represent the floating point IEEE representation of the level status.

## D.12 940 Flow Meter Response Time

As a result of time lags associated with data acquisition, instrumentation could conceivably take up to 12 seconds to respond to a SCADA RS232 request. Therefore, the SCADA system must be designed to accommodate this potential communication lag. For example, in a Wonderware® application running a Modbus ASCII DDE server, the COM port reply time-out must be set to 12 seconds. This is the amount of time that the meter is given to reply to Modbus queries via this serial port.

### Communication Handshaking

The 940 Flow Meter contains minimal communication handshaking. For the meter to identify an RS232 connection from an outside source, and to keep the RS232 hardware active once communicating, the Data Terminal Equipment (DTE) must assert and hold high the DTR line of the DB9 connector (DSR of meter). The 940 Flow Meter does not support RTS/CTS hardware handshaking. Note that DTE must be capable of handling a 12-second maximum response lag.

Pin	Description	Pin	Description	Pin	Description
Pin 1	Data Carrier Detect (DCD) <sup>1</sup>	Pin 4	Data Terminal Ready (DTR)	Pin 7	Request to Send (RTS)
Pin 2	Received Data (RD)	Pin 5	Signal Ground (SG)	Pin 8	Clear to Send (CTS)
Pin 3	Transmitted Data (TD)	Pin 6	Data Set Ready (DSR)	Pin 9	Ring Indicator

<sup>1</sup> Not used.

## D.13 Complications with Floating Point Values

The manufacturer’s implementation of the Modbus protocol was based on the idea that we would enable our flow meters to emulate a Modicon®, Compact 984 PLC. Consequently, we follow the exact same format that Modicon uses for the storing and processing floating point numbers. Additionally, the Modbus protocol does not define how floating point values are packed (stored) into the internal memory addresses or “Registers” of the flow meter. When integrating the Modbus-capable flow meters, be aware that these meters store and process floating point numbers in the exact same format as the Modicon Compact 984 PLC.

All current models of Modicon PLCs, including the Compact 984, pack two bytes of data into each register. This alone presents no problems. Unsigned two-byte (16-bit) integer values in the range of 0 to 65535 can be stored and retrieved from these registers without any problems or complications. The complications arise when the stored value is a floating point value, which by IEEE definition, require 4 bytes (32 bits). The IEEE standard for floating point values states in part that the 8 most significant bits represent the exponent and the remaining 23 bits (plus one assumed bit) represent the mantissa and the sign of the value.

Since a data “word” consists of two bytes, a floating point value is represented by two data words. Because a single Modicon register consists of one word (or 2 bytes), two consecutive Modicon registers are needed to store one floating point value.

The representation of a floating point value can be broken down into a “High Order” and a “Low Order” word. Additionally, each word can be broken down into a high order byte and a low order byte.

Table 20 and Table 21 depict how a IEEE floating point value is usually represented and how the Modicon stores a floating-point value.

The complications arise because Modicon doesn't store floating point values in this standard (IEEE) format. Modicon stores floating point values the opposite way with the “Low-order” word in the first register and the “High-order” word in the second register.

**Table 20 IEEE Floating Point Representation**

First Register (i.e., 4001)		Second Register (i.e., 4002)	
High Word, High Byte	High Word, Low Byte	Low Word, High Byte	Low Word, Low Byte

**Table 21 Floating Point Values Representation**

First Register (i.e., 4001)		Second Register (i.e., 4002)	
Low Word, High Byte	Low Word, Low Byte	High Word, High Byte	High Word, Low Byte

Since the Modbus protocol doesn't define how floating point values are handled or stored, some Modbus-capable servers incorrectly use the normal, “High word — Low word” format for converting the Modbus message response to the client application. Since Modicon stores the floating point values in the opposite order, the result is that the client application may receive an incorrect representation of the floating point value from the Modbus-capable server.

### D.14 Port Expanders and Protocol Converters

In some situations, there may not be a Modbus ASCII port available for use with the 940 Flow Meter. A good example might be where there is a need to install a flow meter at a remote pump site that already has a single Modbus line connected to a PLC that is used to control the pumps.

Port expanders are available from third party manufacturers; these allow several Modbus slave devices to be connected to a single Modbus Master device. Typically, a single port expander has 3–5 separate Modbus ports on it. Depending on the manufacturer, the user may be able to configure each of these ports for different communications parameters. In essence, not only does this type of port expander allow multiple slave devices to be connected to a single Modbus master device, but it can also be configured to convert incompatible communications parameters such as Modbus ASCII to RTU (or vice versa), baud rate, parity, stop bits, etc.

In addition to the port expanders mentioned above, other protocol converters from third-party manufacturers can be used to convert other industrial protocols to Modbus ASCII.

### D.15 Other Reference Material

*SCADA ANSI Specification*. ANSI/IEEE Std. C37. 1–1994.

Boyer, Stuart A. *SCADA supervisory control and data acquisition*. Research Triangle Park, NC: Instrument Society of America. 1993.

MODICON. *Modicon modbus protocol reference guide*. North Andover, MA: MODICON, Inc., Industrial Automation Systems. 1996.

AEG Schneider Automation. *Modicon ladder logic block library user guide*. North Andover, MA: AEG Schneider Automation, Inc. 1996.

### D.16 Troubleshooting Tips

**Problem: 940 Flow Meter responds to some Modbus messages but not all**

**Response: Check the Register Addresses**

The flow meter only responds to valid Modbus message requests. If a Modbus message sent to the flow meter asks for stored register addresses for values that are outside of the address range currently supported by the meter, the meter ignores the request.

The flow meter currently only supports register addresses 40001 through 40083. Consequently, a request to read the value in any register address greater than 40083 will be ignored. If a range of registers is requested and that range includes register addresses greater than 40083, the entire request will be ignored.

**Response: Check the number of registers being polled**

Additionally, the 940 Flow Meter checks all Modbus messages to see if the correct number of registers is requested for the type of data being returned. The meter ignores the request if the number of registers requested does not coincide with the correct number of registers needed to accurately display the data. For example, Velocity is a floating point value stored in register 40009–40010. Because all floating point values require two registers, the meter would ignore a request to read just the data in register 40009, yet it would respond correctly to a request to read the data stored in both registers 40009 AND 40010. Consequently, if the meter received a single request to read both Level 40007–40008 and Velocity 40009–40010, the request would have to be for an even number of registers for the meter to respond.

### **Problem: 940 Flow Meter does not respond to any Modbus message requests**

*Note: It is imperative that the DTR be asserted prior to the communication session and that it remains asserted throughout the entire communication session.*

#### **Response: Check the DTR Signal/Line**

The 940 Flow Meter will not respond to any Modbus messages until the device connected to the RS232 port asserts (raises) the DTR line (DB-9, Pin 4 on the 1727 cable).

#### **Response: Check the Baud Rate**

The baud rate of the 940 Flow Meter is configured from 1200–19,200 and must match the baud rate of the device communicating with the meter.

#### **Response: Check the Communication Parameters**

The communications parameters of the 940 Flow Meter meter are fixed (except for the baud rate) and can not be changed. The device communicating with the flow meter must be configured with the exact same communication parameters as the meter. These parameters are as follows:

- 7 Data Bits
- 1 Stop bit
- 1 Start bit
- Even parity

#### **Response: Check the Modbus Device Address assigned to the 940 Flow Meter**

Modbus devices, including the 940 Flow Meter, have a unique configured device address in the range of 1 to 247. This address is embedded in the first two characters of the Modbus message. The flow meter only responds to messages encoded with the same address as the meter. If the meter receives a valid Modbus message with an encoded device address other than the address the meter is configured for, it ignores that message.

#### **Response: Check the Modbus mode**

There are two different forms of Modbus: ASCII and RTU. Currently the 940 Flow Meter only support Modbus ASCII. Consequently the device communicating with the meter must be set up for Modbus ASCII. The meter will not respond to Modbus RTU messages.

### **Problem: The data values being returned by polling the meter with Modbus are not the same as the data values displayed in the current status screen of the meter.**

#### **Response: Confirm that the correct register addresses are being polled.**

Check to make sure the register address being polled corresponds to the correct data channel. For example, if polling for FLOW, make sure the server or MMI is requesting data from registers 40033–40034.

If polling for several values at the same time, try changing the polling so that only one value is polled at a time. Then check to see if the polled value matches a different data channel in the meter. For example, if polling for Level and it appears that the data for Velocity is displayed instead, then probably the wrong registers are being polled.

#### **Response: Check the data format of the Modbus server.**

When configuring a Modbus server or MMI application to poll a 940 Flow Meter, it is absolutely essential that the correct data format is selected for that particular data channel (register). For example, when polling for Flow, Level or Velocity, which are all floating point values, the Modbus server or MMI must be configured to read these values as floating point values. If the server or MMI is formatting this data as a data type other than floating point, the values will not be read or displayed correctly.

Likewise, if polling the meter for engineering units, which are represented by integer values, such as Flow Units of Measure or Level Units of Measure, the Modbus server or MMI must be configured to read these values as Integers. If the server or MMI is formatting this data as any data type other than Integer, the values will not be read or displayed correctly.

Different Modbus servers and MMI manufacturers have different methods for configuring the application to the appropriate data type contained within the register. Contact the server or MMI manufacturer for details on how to configure the application to read the data in the correct format.

<b>B</b>	
Batteries and Chargers .....	87
Battery Compartment Desiccant .....	32, 57
Battery Disposal .....	87
Battery Internal Memory .....	58
Battery Life .....	32
Battery Storage .....	87
<b>C</b>	
Cleaning the Flow Meters .....	58
Combined Sewer Overflow (CSO) Application .....	84
Continuity Channel .....	85
<b>D</b>	
Data Analysis Software .....	41
Data Retrieval .....	41
Desiccant Maintenance .....	57
Difficult Sites .....	13
Downlook Ultrasonic Sensor .....	43
Dry Channel .....	82
<b>E</b>	
Elbows, Sharp turns, and “Y” connections .....	13
Event Input .....	36
<b>F</b>	
Flow Equations .....	41
Flow proportional sampling .....	37
Flow Pulse Output .....	36
Fuses .....	58
<b>I</b>	
In-Pipe Ultrasonic Sensor .....	49
Installation Considerations .....	13
Installing the Battery Pack .....	30
Intrinsically Safe Equipment .....	8
Intrinsically Safe Installation Requirements .....	8
Intrinsically Safe Wiring Practices .....	9
Invisible Range .....	43
<b>L</b>	
Ladder Rungs .....	43
Lead Acid (Gel-Cell) .....	87
<b>M</b>	
Maintenance .....	57
Memory Batteries .....	58
Multiple Source Monitoring at a Single Site .....	83
<b>O</b>	
Optically Isolated Interface .....	41
O-Ring Gasket .....	57
O-rings Replacement .....	57
Outfalls .....	13
<b>P</b>	
Precautionary Labels .....	7
Programming and Analysis .....	41
Protecting the Sensor .....	44
<b>R</b>	
RAM memory .....	58
RS232 Batteries .....	59
RS232 Interface .....	59
RS232 Interface Wiring .....	35
RS232 Serial Port .....	35
<b>S</b>	
Safety Precautions .....	7
Sampler Connector Pin Assignments .....	36
Sampler Interface Wiring .....	37
Sampler Receptacle .....	37
SCADA-Modbus® .....	91
Seals .....	10, 57
Sensor Configurations .....	13
Sensor Installation .....	43
Sewer System Management Software .....	41
Site Selection .....	13
Software and Communications .....	41
Special Output/Sample Output .....	38
Specifications .....	3
911 .....	3
940 .....	4
Storing the Flow Meters .....	58
<b>V</b>	
Vertical Drops .....	13
<b>W</b>	
Warranty .....	73