

POWER REQUIREMENTS:

12 VDC SUPPLIED BY OPTIONAL BATTERY OR A/C POWER SUPPLY.

TEMPERATURE:

GENERAL USE: 0 TO 49 °C (32 TO 120 °F)

STORAGE: -30 TO 60 °C (-22 TO 140 °F)

WEIGHTS:

COMPACT: 10.5kg [23.1 lbs] LESS BOTTLE SET & POWER SOURCE

STANDARD: 12kg [26.5 lbs] LESS BOTTLE SET & POWER SOURCE

LARGE: 12.2kg [26.8 lbs] LESS BOTTLE SET & POWER SOURCE

BATTERY: 2.4kg [5.3 lbs]

POWER SUPPLY: 1.2kg [2.6 lbs]

REVISION		
REV	DESCRIPTION	APPROVED
A	Production Release	Matt Collier

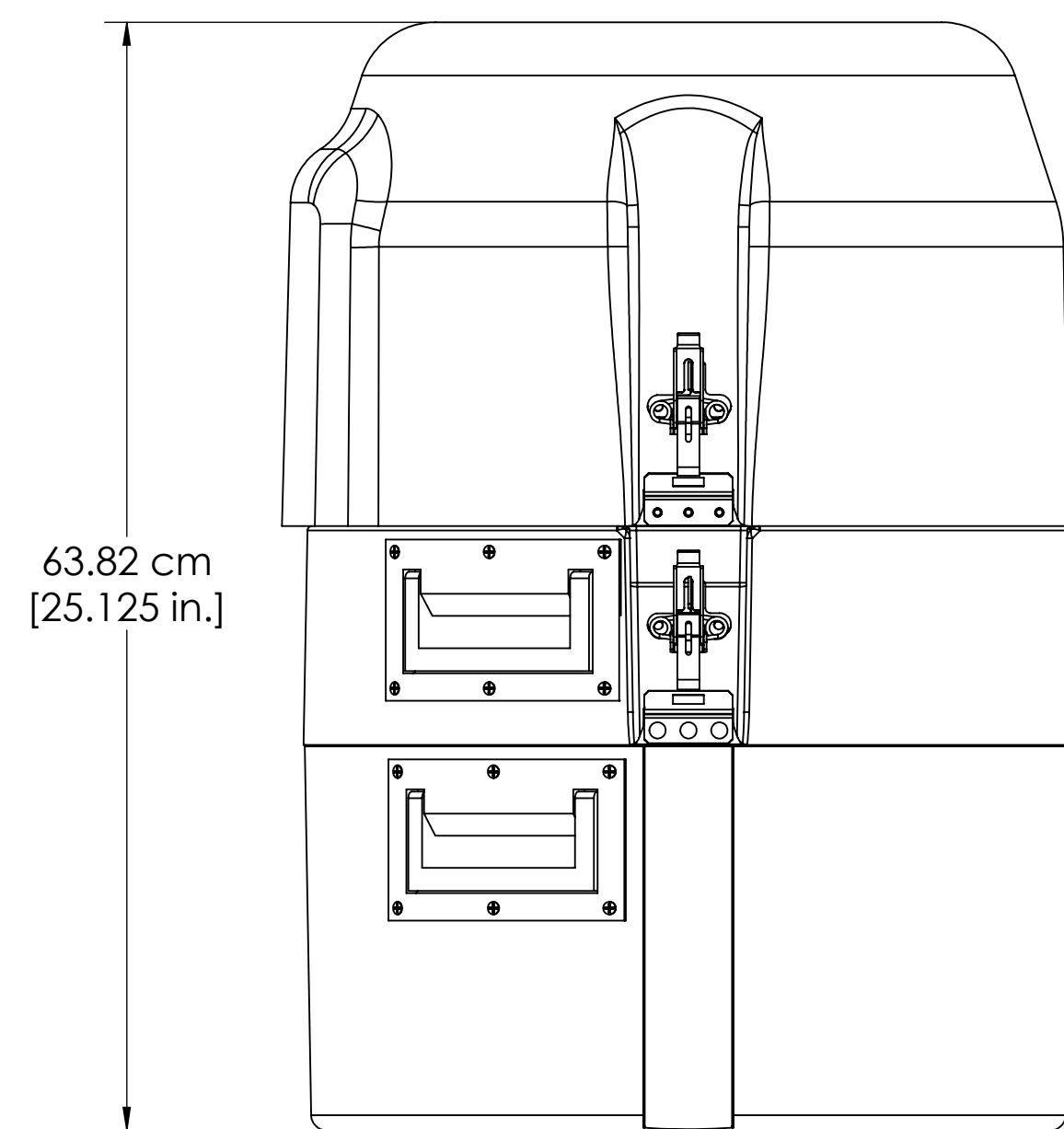
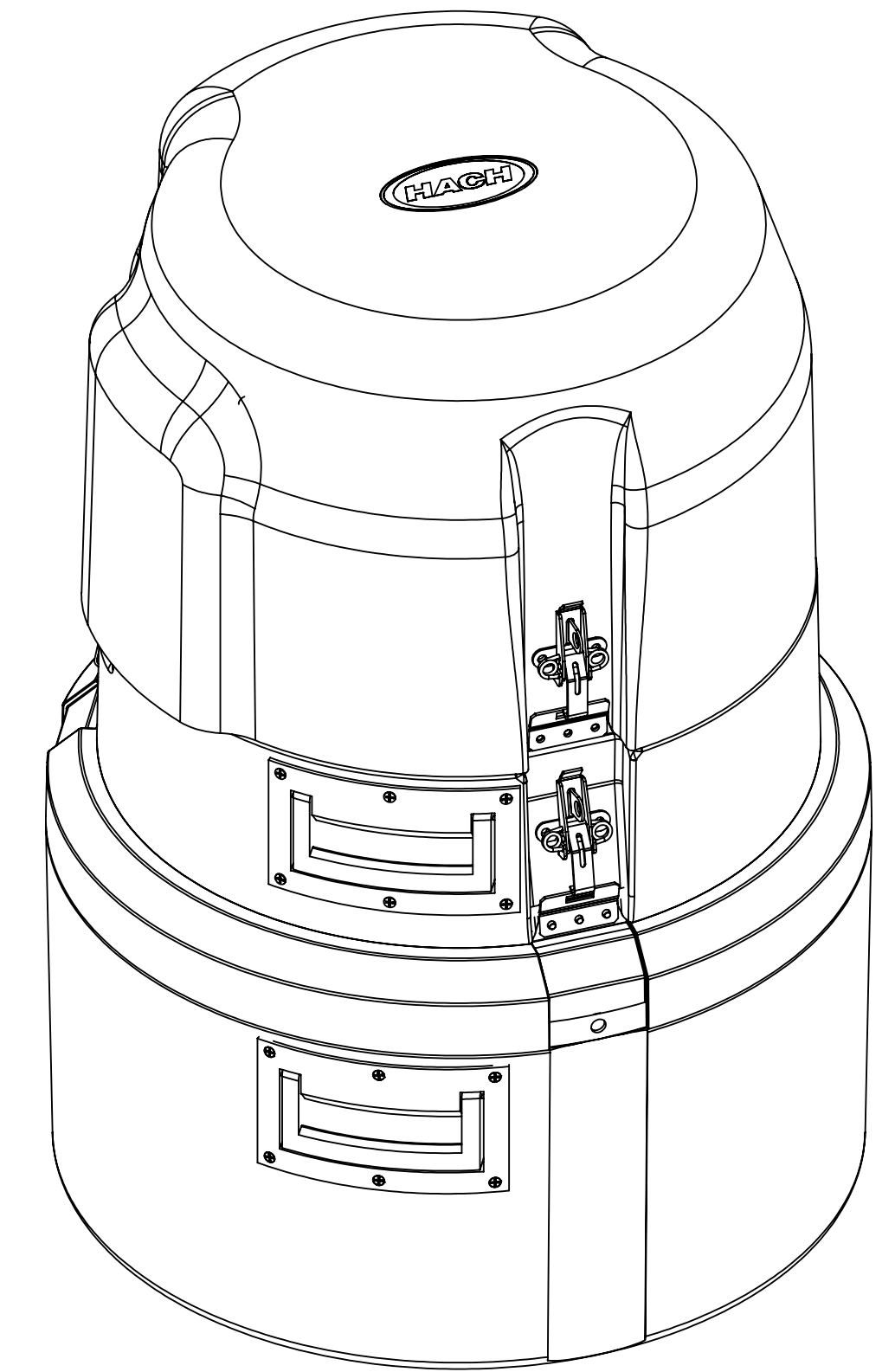
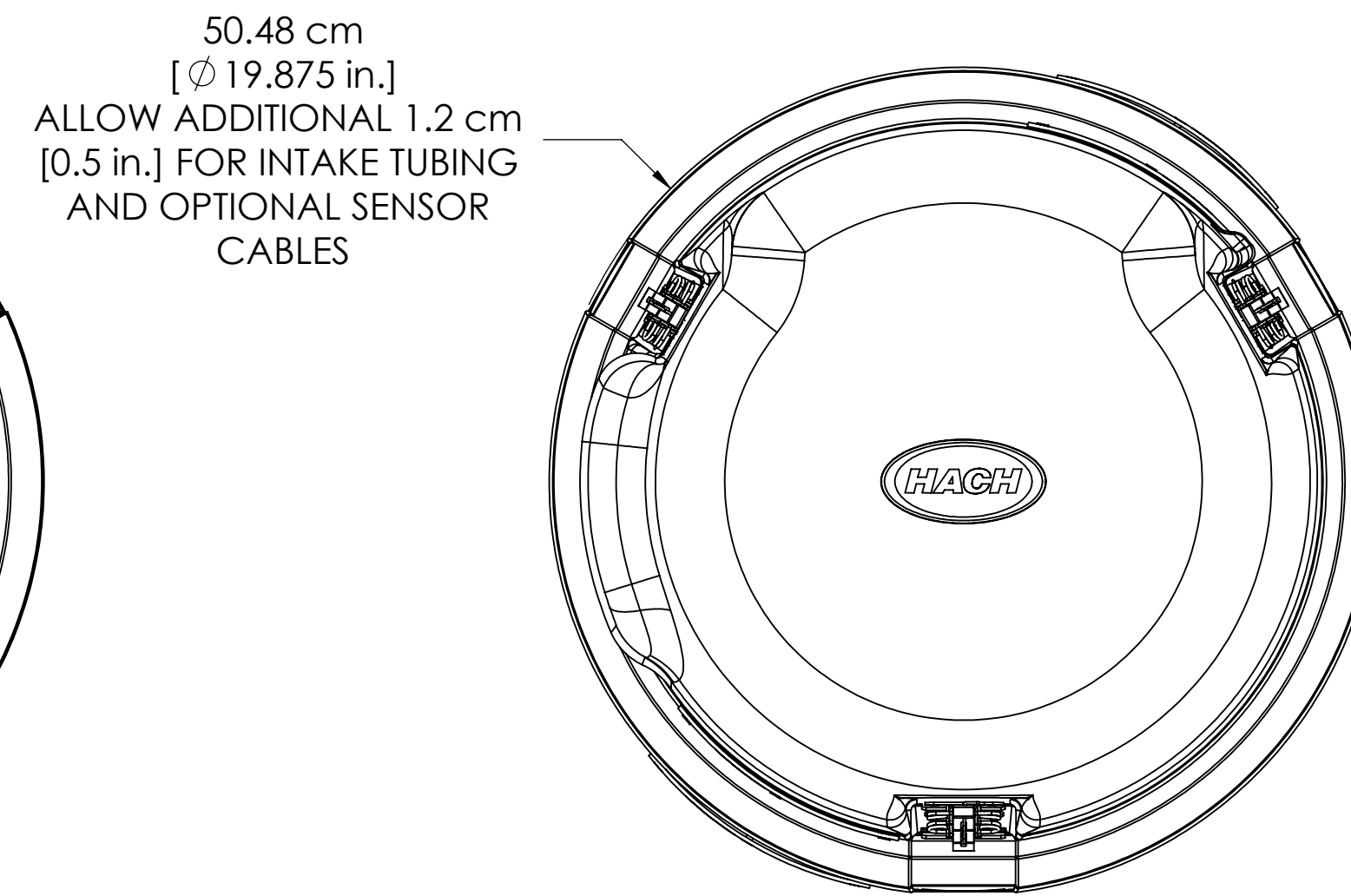
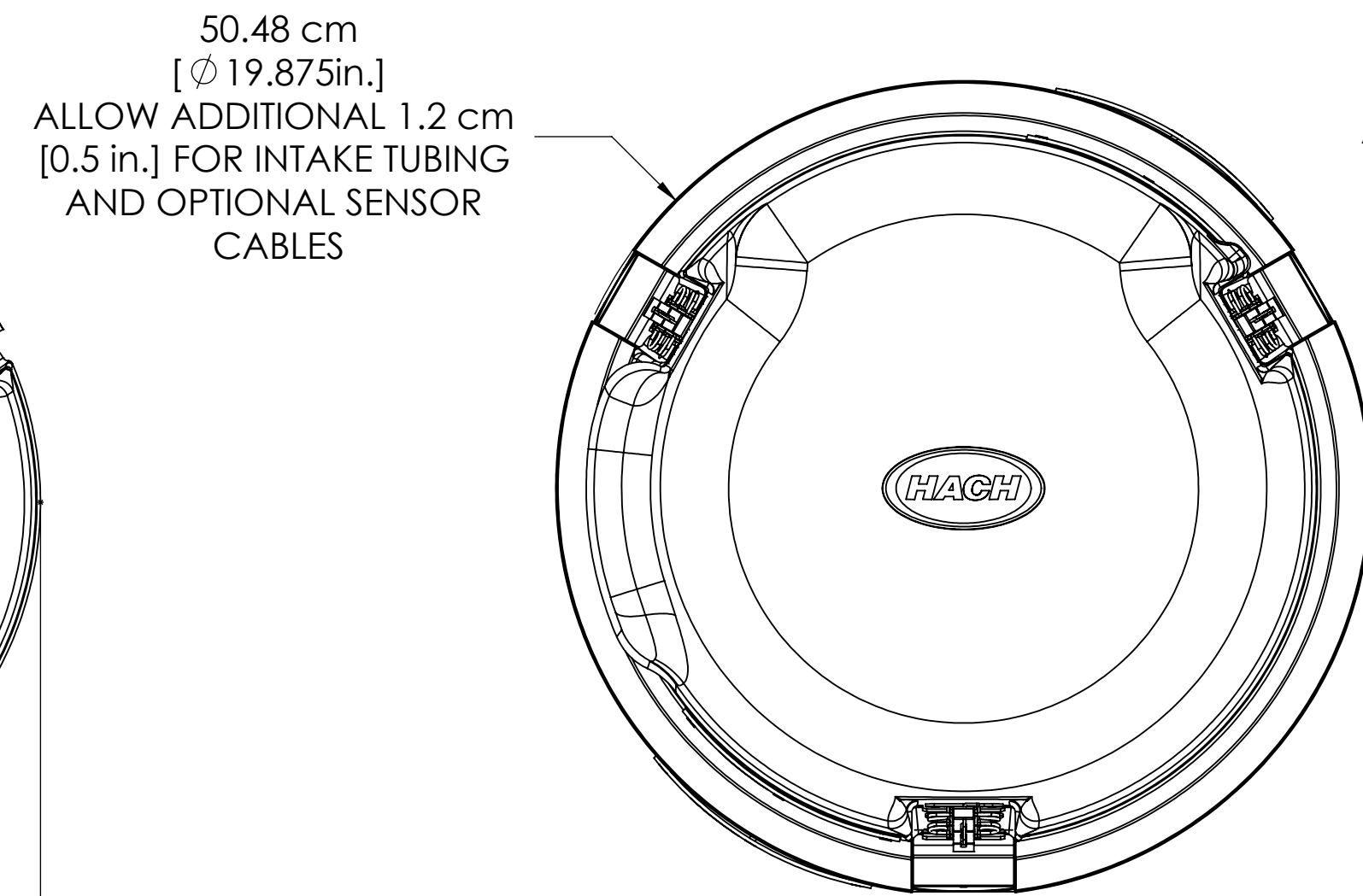
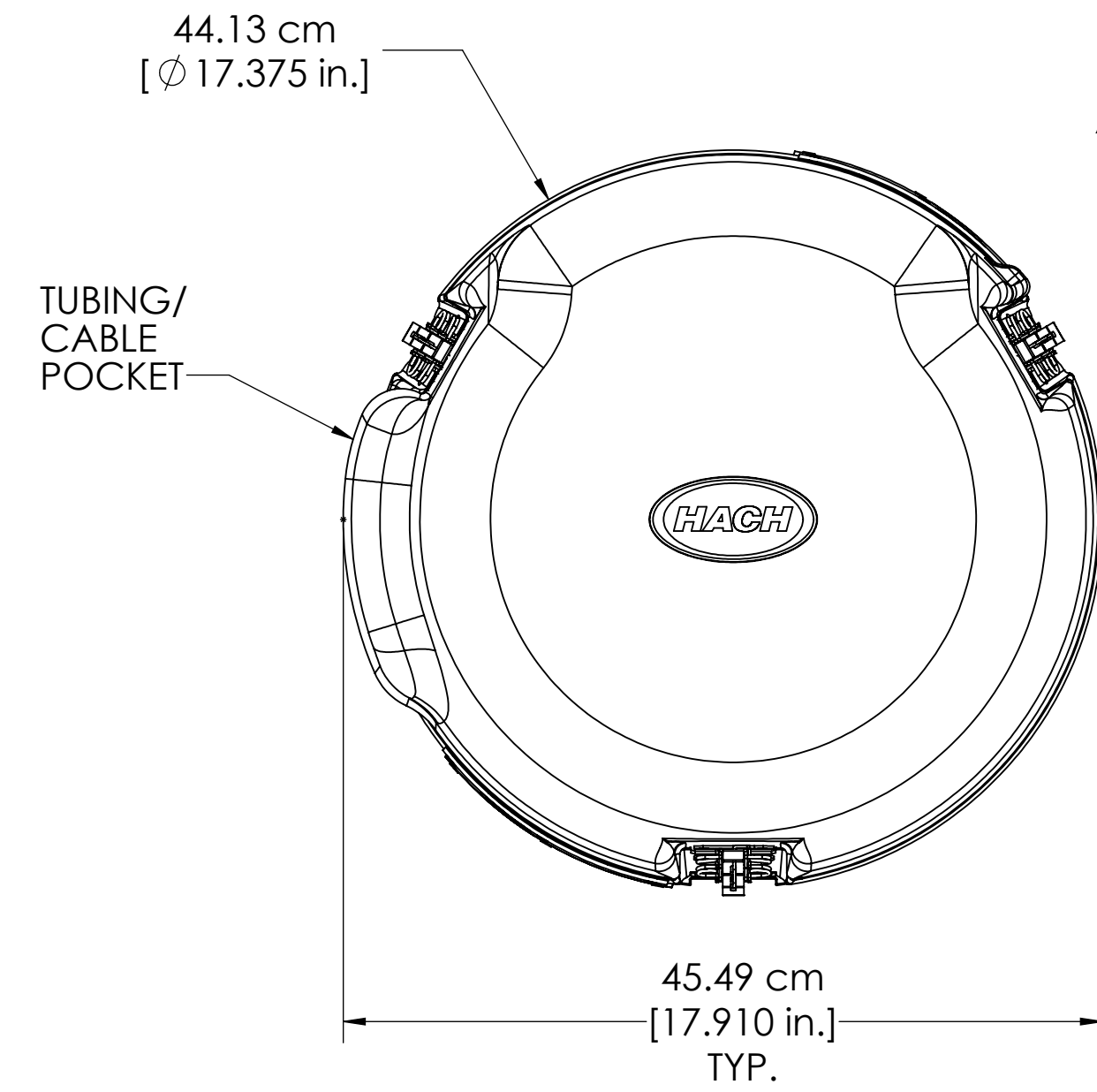

COMPACT BASE

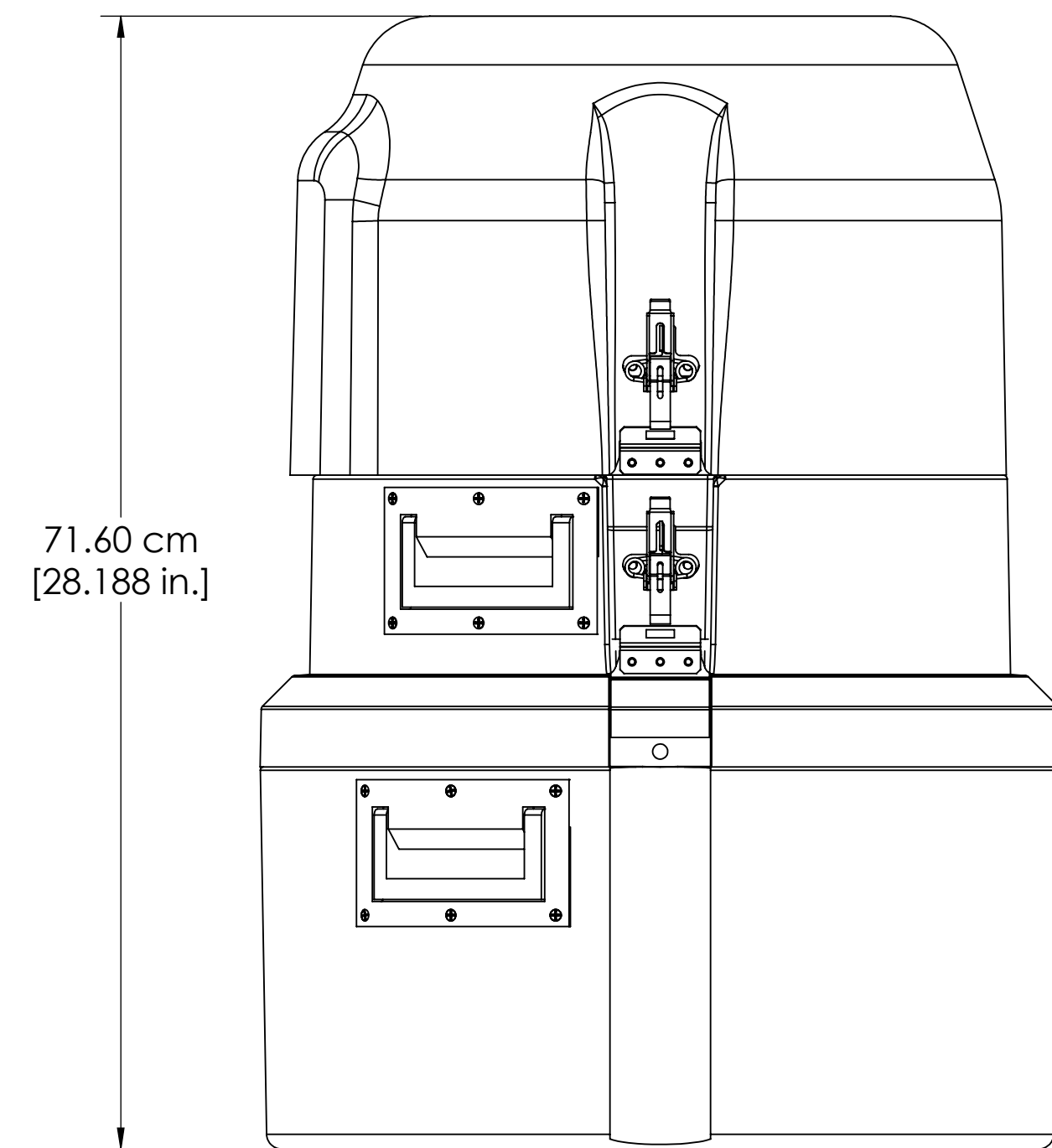

STANDARD BASE

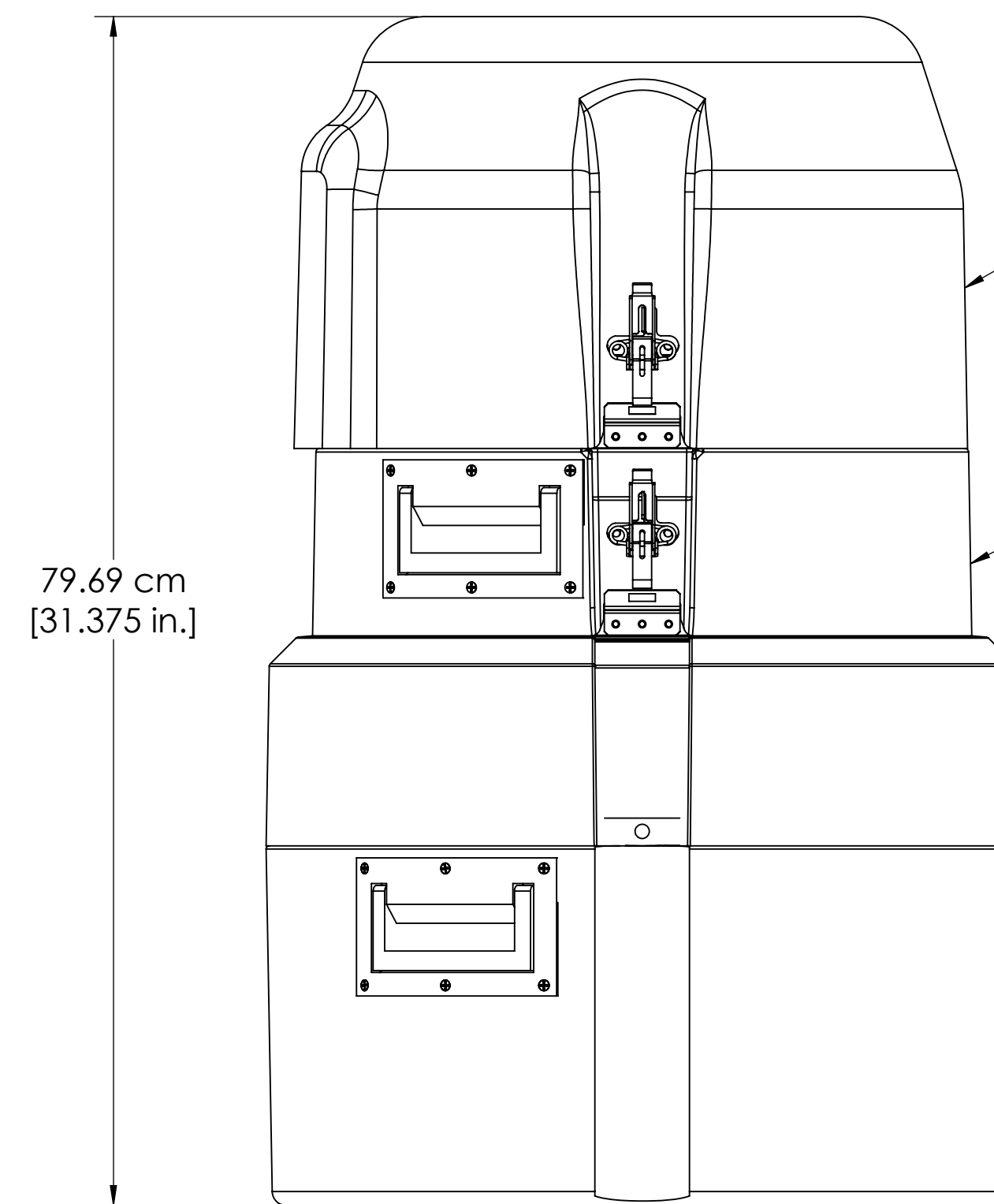

LARGE BASE

COVER HOUSES
CONTROLLER AND
POWER SOURCE

CENTER SECTION
HOUSES DISTRIBUTOR OR
FULL-BOTTLE SHUTOFF

BASE HOUSES BOTTLE SET

NOTICE-HACH COMPANY CLAIMS PROPRIETARY RIGHTS IN THE INFORMATION DISCLOSED ON THIS DRAWING. IT IS ISSUED IN CONFIDENCE FOR ENGINEERING INFORMATION ONLY AND MAY NOT, IN WHOLE OR IN PART, BE USED TO MANUFACTURE ANYTHING, WHETHER OR NOT SHOWN HEREON, REPRODUCED OR DISCLOSED TO ANYONE WITHOUT DIRECT PERMISSION FROM HACH COMPANY.

MATERIAL	UNLESS OTHERWISE SPECIFIED: DIMENSIONS ARE IN INCHES TOLERANCES: X = ±.03 XX = ±.01 XXX = ±.005 ANGLES = ±.25°	NAME R. LUTHER	DATE 3/2/15	<p>HACH COMPANY 5600 LINDBERGH DR. LOVELAND, CO. 80539</p>
INTERPRET GEOMETRIC TOLERANCING PER: ANSI Y14.5M 1994	THIRD ANGLE PROJECTION	ENGINEER R. LUTHER	DATE 2/16/15	
DO NOT SCALE THIS SHEET		<p>TITLE: SUBMITTAL DRAWING, PORTABLE SAMPLER</p> <p>SIZE DWG. NO. D ASP.XXXXXX87</p> <p>SCALE: 1:4 WEIGHT: SHEET 1 OF 2</p>		<p>REV A</p>

41.28 cm
[16.250 in.]
P/N: 1355 OPTIONAL SUSPENSION
HARNESS HEIGHT ADDER

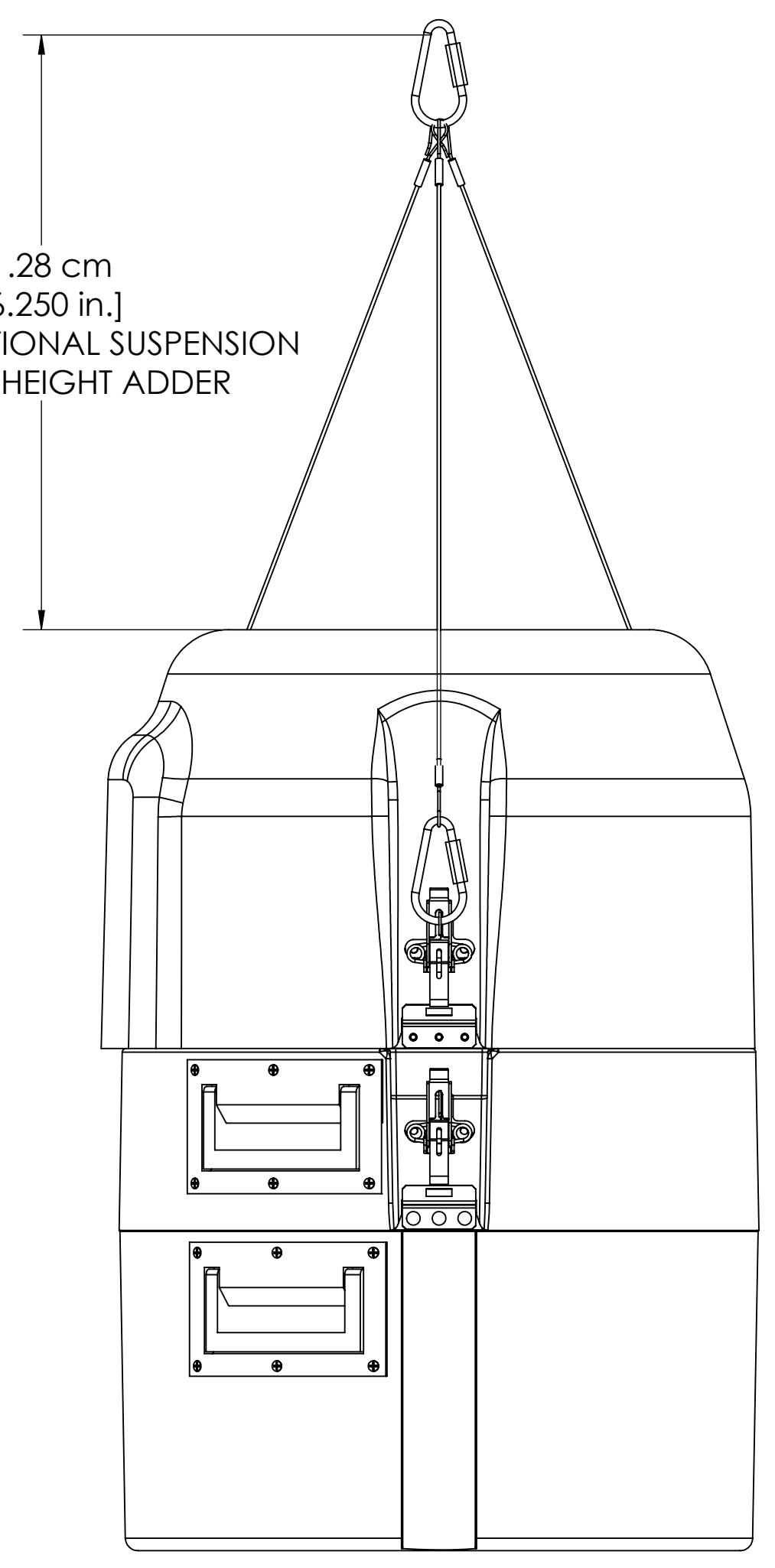

SUSPENSION OR
LOCKING POINTS

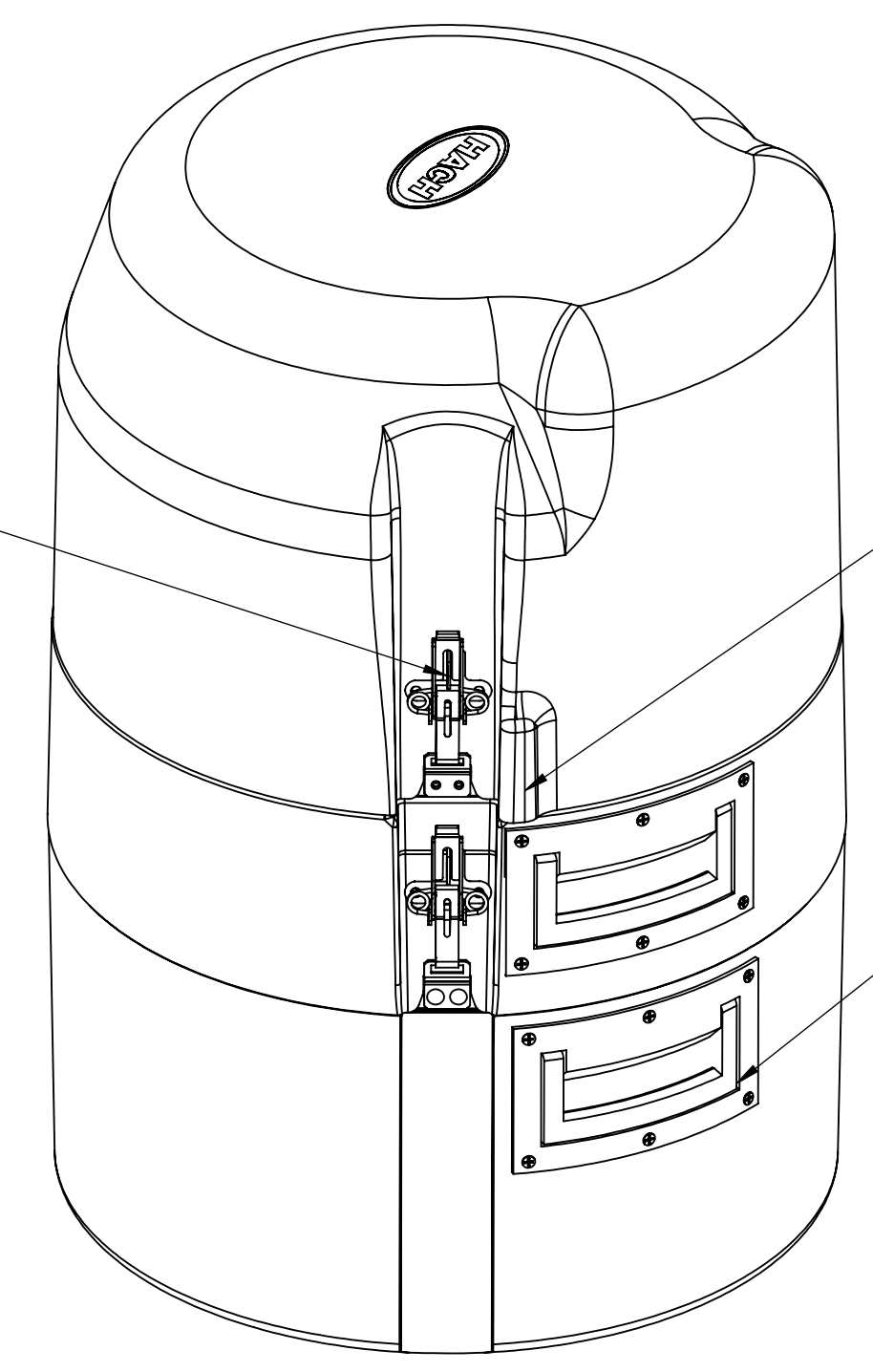

OPTIONAL POWER
SUPPLY CABLE EXIT
LOCATION

FLIP OUT HANDLES
EXTEND 3.56CM [1.4 IN.]
FROM THE UNIT.