



DOC023.54.03211

NITRATAX sc

USER MANUAL

12/2022, Edition 7

Section 1 Specifications	3
Section 2 General Information	7
2.1 Safety information.....	7
2.2 Canadian interference-causing equipment regulation, IECS-003, class A.....	7
2.3 FCC part 15, class "A" limits.....	7
2.3.1 Use of hazard information.....	8
2.3.2 Precautionary labels.....	8
2.4 Product overview.....	9
2.5 Theory of operation.....	10
Section 3 Installation	11
3.1 Installation overview.....	11
3.2 Unpack the sensor.....	12
3.3 Wiring safety information.....	12
3.4 Sensor connection and wiring.....	12
Section 4 System Start Up	15
4.1 Power the instrument.....	15
Section 5 Operation	17
5.1 Use of an sc controller.....	17
5.2 Sensor setup.....	17
5.3 Sensor data logging.....	17
5.4 Sensor diagnostics menu.....	18
5.5 Sensor setup menu.....	18
5.6 Sensor calibration.....	20
5.6.1 Adjusting turbidity compensation.....	22
Section 6 Maintenance	23
6.1 Maintenance schedule.....	23
6.2 Clean the measuring path.....	24
6.3 Change the wiper profile.....	25
6.4 Check the calibration.....	26
Section 7 Troubleshooting	29
7.1 Error messages.....	29
7.2 Warnings.....	29
Section 8 Replacement Parts and Accessories	31
Section 9 Limited Warranty	33
Index	37

Section 1 Specifications

Specifications are subject to change without notice.

The product has only the approvals listed and the registrations, certificates and declarations officially provided with the product. The usage of this product in an application for which it is not permitted is not approved by the manufacturer.

Component	NITRATAX <i>plus</i> sc	NITRATAX <i>eco</i> sc	NITRATAX <i>clear</i> sc
NITRATAX sc tank sensor			
Measuring technique	UV absorption measurement, reagent-free		
Measuring method	Patented 2-beam method		
Measuring path	1 mm (0.04 in.), 2 mm (0.08 in.), 5 mm (0.20 in.)	1 mm (0.04 in.)	5 mm (0.20 in.)
Measuring range with NO ₃ -N standard solutions	0.1-100.0 mg/L NO ₂₊₃ -N (1 mm/0.04 in.) 0.1-50.0 mg/L NO ₂₊₃ -N (2 mm/0.08 in.) 0.1-25.0 mg/L NO ₂₊₃ -N (5 mm/0.20 in.)	1.0-20.0 mg/L NO ₂₊₃ -N	0.5-20.0 mg/L NO ₂₊₃ -N
Lower detection limit (mg/L) NO ₃ -N	0.1 (5 mm/0.20 in.)	1	0.5
Upper detection limit (mg/L) NO ₃ -N	100 (1 mm/0.04 in.)	20	20
Measuring error (mg/L) NO ₃ -N	±3 % of the mean MW ±0.5	±5 % of the mean MW ±1.0	±5 % of the mean MW ±0.5
Resolution (mg/L)	0.1	0.5	0.1
Sludge compensation	yes	yes	—
Measuring interval (>= min)	1	5	5
T100 response time (min)	1	15	5
Integration	>1 min, adjustable	15-30 min, adjustable	>5 min, adjustable
Power consumption	2 W		
Cable length	10 m (30 ft)		
Sensor pressure limit	maximum 0.5 bar (7 psi)		
Ambient temperature	2 to 40 °C (36 to 100 °F)		
Dimensions D x L (Figure 1 on page 5)	approximately 70 x 229-333 mm (3 x 13.1 in.)	approximately 75 x 323 mm (3 x 12.9 in.)	approximately 75 x 327 mm (3 x 12.7 in.)
Weight	approximately 3.6 kg (7.9 lb)	approximately 3.3 kg (7.3 lb)	approximately 3.3 kg (7.3 lb)
NITRATAX sc sensors flow through units			
Sample flow rate	0.5-10 L/h sample	—	0.5-10 L/h sample
Sample connection	Tube ID 4 mm/AD 6 mm	—	Tube ID 4 mm/AD 6 mm
Sample temperature	2 to 40 °C (36 to 100 °F)	—	2 to 40 °C (36 to 100 °F)
Dimensions	W x H x D approximately 500 x 210 x 160 mm (20 x 8.3 x 6.3 in.)	—	W x H x D approximately 500 x 210 x 160 mm (20 x 8.3 x 6.3 in.)

Specifications

Component	NITRATAX <i>plus</i> sc	NITRATAX <i>eco</i> sc	NITRATAX <i>clear</i> sc
Weight (without sensor)	approximately 3.6 kg (7.9 lb)	—	approximately 3.6 kg (7.9 lb)
NITRATAX sc sensor material			
Sensor			
Sensor enclosure	Stainless steel 1.4571		Stainless steel 1.4581
Wiper axle	Stainless steel 1.4104	Stainless steel 1.4571	
Cable gland	Stainless steel 1.4305		
Profile carrier 1 mm/2 mm	Stainless steel 1.4310		
Wiper arm 5 mm	Stainless steel 1.4581		
Wiper profile	Silicone		
Measuring windows	SUPRASIL (quartz glass)		
Enclosure seals	Silicone		
Seal, cable gland	PVDF		
Sensor cable	PUR 10 m (33 ft) standard Optional extension cables available in 5, 10, 15, 20, 30, 50 m Total maximum length: 60 m (196 ft)		
Struts			
Adaptor for filtration sensor	Stainless steel 1.4308		
Struts	Stainless steel 1.4301		
Flow through cell (bypass)			
Measuring cell	PVC		
Seals	EPDM		
Glands	PVDF		
Sample tube	PVC		

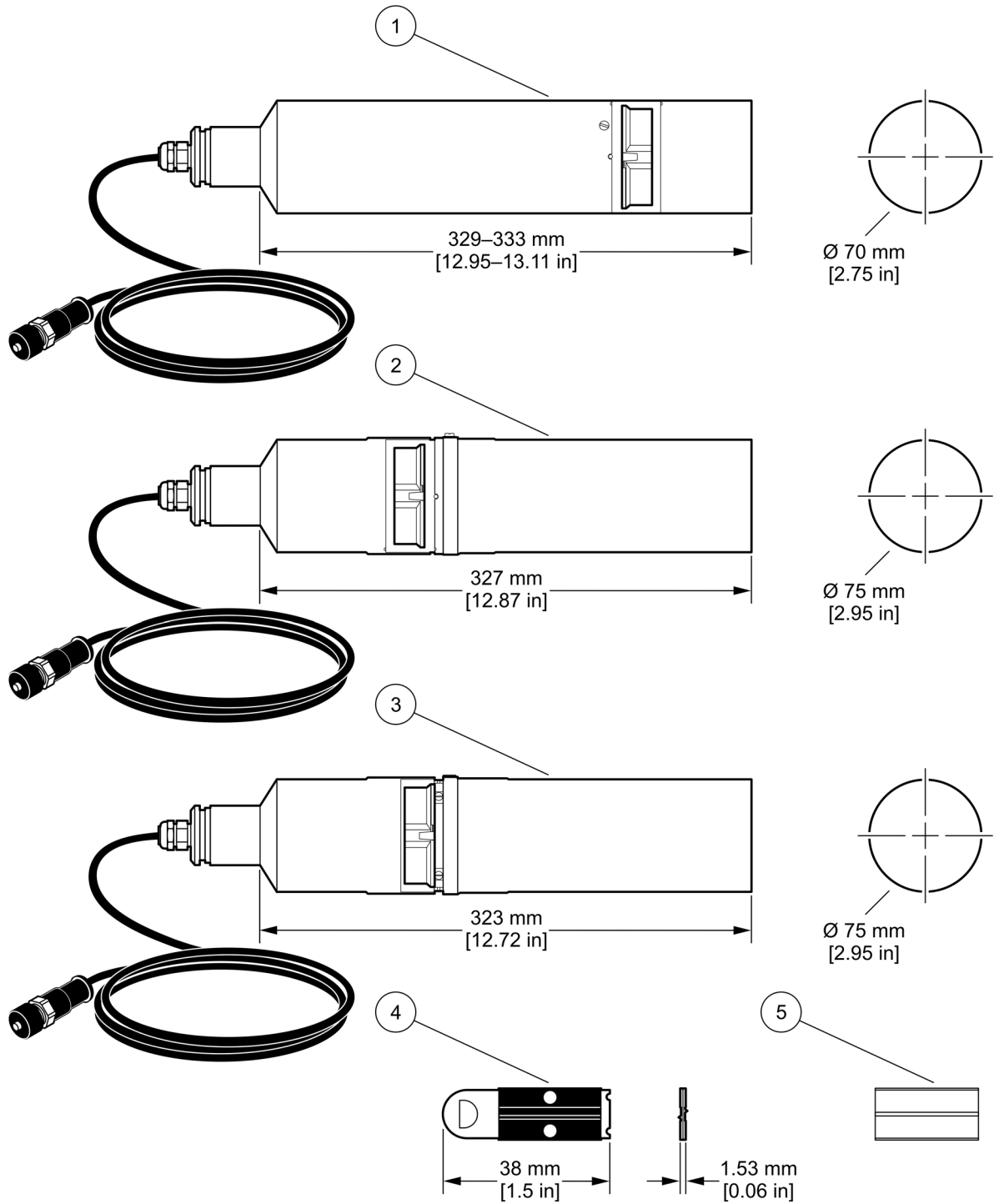

Figure 1 Sensor dimensions

1	NITRATAX plus sc	4	Wiper profile 1 and 2 mm (0.04 in. and 0.08 in.)
2	NITRATAX clear sc	5	Wiper profile 5 mm (0.20 in.)
3	NITRATAX eco sc		

Section 2 General Information

2.1 Safety information

Please read this entire manual before unpacking, setting up or operating this equipment. Pay attention to all danger and caution statements. Failure to do so could result in serious injury to the operator or damage to the equipment.

Make sure that the protection provided by this equipment is not impaired, do not use or install this equipment in any manner other than that specified in this manual.

2.2 Canadian interference-causing equipment regulation, IECS-003, class A

Supporting test records by Hewlett Packard, Fort Collins, Colorado Hardware Test Center (A2LA # 0905-01) and certified compliance by Hach Company.

This Class A digital apparatus meets all requirements of the Canadian Interference-Causing Equipment Regulations.

Cet appareil numérique de la classe A respecte toutes les exigences du Règlement sur le matériel brouilleur du Canada.

2.3 FCC part 15, class "A" limits

Supporting test records by Hewlett Packard, Fort Collins, Colorado Hardware Test Center (A2LA # 0905-01) and certified compliance by Hach Company.

This device complies with Part 15 of the FCC Rules. Operation is subject to the following two conditions:

(1) this device may not cause harmful interference, and (2) this device must accept any interference received, including interference that may cause undesired operation.

Changes or modifications to this unit not expressly approved by the party responsible for compliance could void the user's authority to operate the equipment.

This equipment has been tested and found to comply with the limits for a Class A digital device, pursuant to Part 15 of the FCC Rules. These limits are designed to provide reasonable protection against harmful interference when the equipment is operated in a commercial environment. This equipment generates, uses, and can radiate radio frequency energy and, if not installed and used in accordance with the instruction manual, may cause harmful interference to radio communications. Operation of this equipment in a residential area is likely to cause harmful interference, in which case the user will be required to correct the interference at his own expense. The following techniques of reducing the interference problems are applied easily.

1. Disconnect the sc controller from its power source to verify that it is or is not the source of the interference.
2. If the sc controller is connected into the same outlet as the device with which it is interfering, try another outlet.
3. Move the sc controller away from the device receiving the interference.
4. Reposition the receiving antenna for the device receiving the interference.
5. Try combinations of the above.

General Information

2.3.1 Use of hazard information

⚠ DANGER
Indicates a potentially or imminently hazardous situation which, if not avoided, will result in death or serious injury.

⚠ WARNING
Indicates a potentially or imminently hazardous situation which, if not avoided, could result in death or serious injury.







⚠ CAUTION
Indicates a potentially hazardous situation that may result in minor or moderate injury.

NOTICE
Indicates a situation which, if not avoided, may cause damage to the instrument. Information that requires special emphasis.

Note: Information that supplements points in the main text.

2.3.2 Precautionary labels

Read all labels and tags attached to the instrument. Personal injury or damage to the instrument could occur if not observed. A symbol, if noted on the instrument, will be included with a danger or caution statement in the manual.

	This symbol, if noted on the instrument, references the instruction manual for operation and/or safety information.
	Electrical equipment marked with this symbol may not be disposed of in European public disposal systems after 12 August of 2005. In conformity with European local and national regulations (EU Directive 2002/96/EC), European electrical equipment users must now return old or end-of life equipment to the Producer for disposal at no charge to the user. Note: For return for recycling, please contact the equipment producer or supplier for instructions on how to return end-of-life equipment, producer-supplied electrical accessories, and all auxiliary items for proper disposal.
	This symbol, when noted on a product enclosure or barrier, indicates that a risk of electrical shock and/or electrocution exists.
	This symbol, if noted on the product, indicates the need for protective eye wear.
	This symbol, when noted on the product, identifies the location of the connection for Protective Earth (ground).
	This symbol, when noted on the product, identifies the location of a fuse or current limiting device.

2.4 Product overview

The **NITRATAX plus sc** (Figure 2, item 1) measures the nitrate concentration up to 100 mg/L N directly immersed in the medium. Use the sensor without the need for pumping and conditioning in activated sludge tanks in municipal sewage treatment plants, surface water, untreated water and treated drinking water. The system can also be used for checking the outlet on waste water treatment plants.

The **NITRATAX eco sc** (Figure 2, item 2) measures the nitrate concentration up to 20 mg/L N directly immersed in the medium. Use the sensor without the need for pumping and conditioning in activated sludge tanks in municipal sewage treatment plants.

The **NITRATAX clear sc** (Figure 2, item 3) measures the nitrate concentration up to 20 mg/L N directly immersed in the medium. Use the sensor without the need for pumping and conditioning in clear media such as surface water, treated drinking water and sewage treatment plant outlets.

Note: The flow-through units of the high precision NITRATAX plus sc and the NITRATAX clear sc sensors are used wherever direct measurement in the medium is not possible for structural reasons, or the medium load makes it necessary to measure a filtered sample (very high TS content, sewage treatment plant inlet, waste dump leachate, etc.).

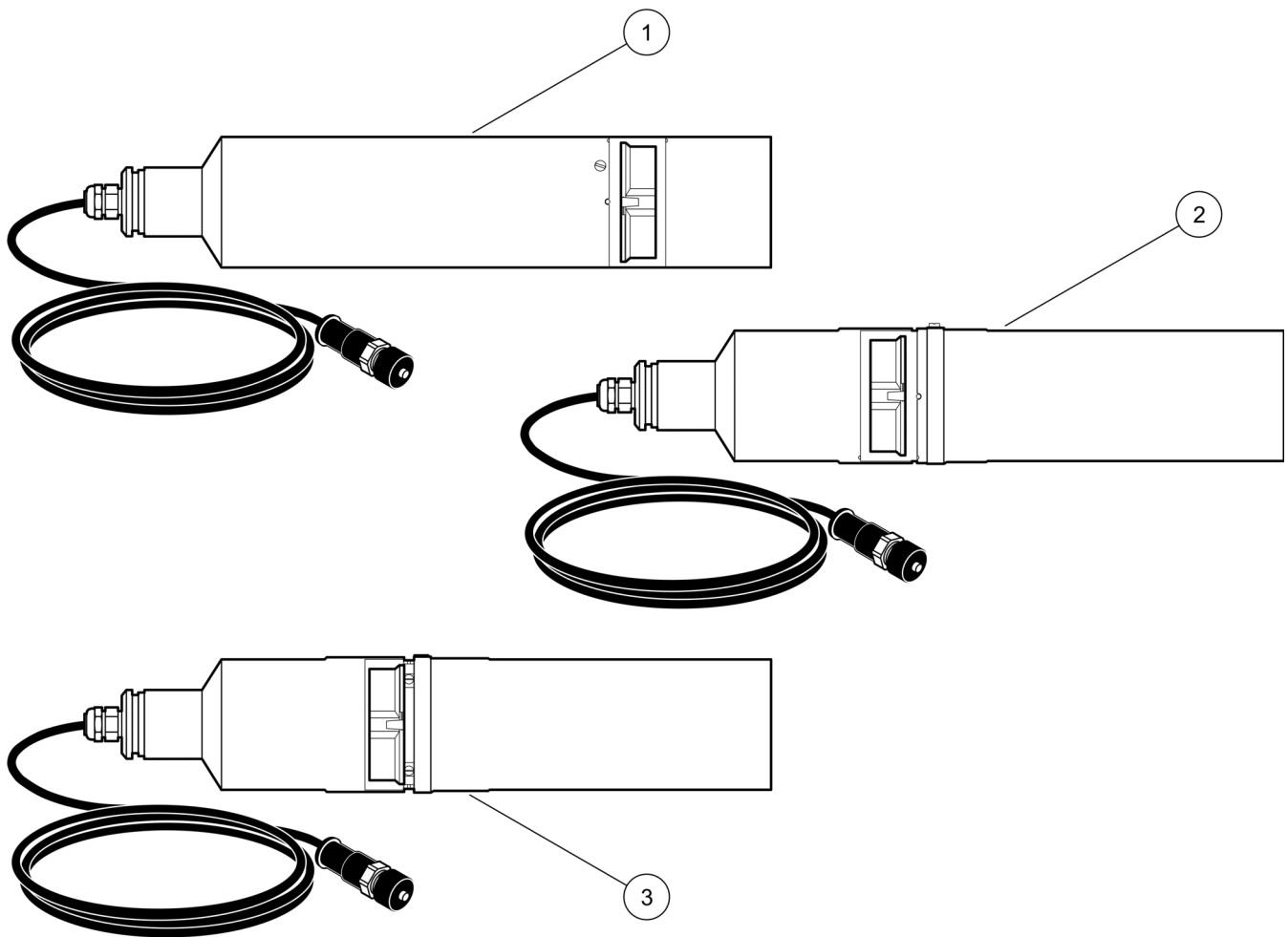

Figure 2 NITRATAX sc sensor versions

1 NITRATAX sc plus	2 NITRATAX sc eco	3 NITRATAX sc clear
--------------------	-------------------	---------------------

2.5 Theory of operation

Nitrate dissolved in water absorbs UV light with wavelengths below 250 nm. This inherent absorption by nitrate makes it possible to photometrically determine the nitrate concentration without reagents by using a sensor positioned directly in the medium. As the measuring principle (Figure 3) is based on the evaluation of (invisible) UV light, the color of the medium has no effect.

The sensor contains a two-beam absorption photometer with turbidity compensation. The measuring window is mechanically cleaned using a wiper.

The measuring and cleaning intervals can be entered using the related controller. The measured value is displayed as NO_x-nitrogen in mg/L NO_x-N (NO₂-N is included in the measured result as nitrite nitrogen) and provided on current outputs. Various operating modes for the outputs permit local regulation without further process data processing.

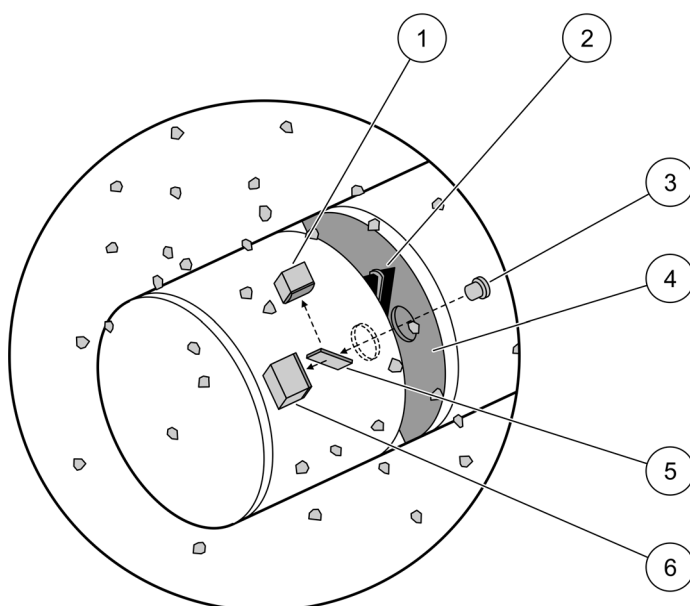

Figure 3 Measurement principle of the NITRATAX sc

1	Receiver, Reference Element	3	UV Lamp	5	Mirror
2	Two-sided Wiper	4	Measurement Slit	6	Receiver, Measuring Element

Section 3 Installation

⚠ CAUTION

Installation of this system may only be carried out by qualified experts in accordance with all local safety regulations. See the mounting instruction sheet for more information.

3.1 Installation overview

Figure 4 shows an example of a NITRATAX sc sensor attached to an sc controller with a bracket installation option.

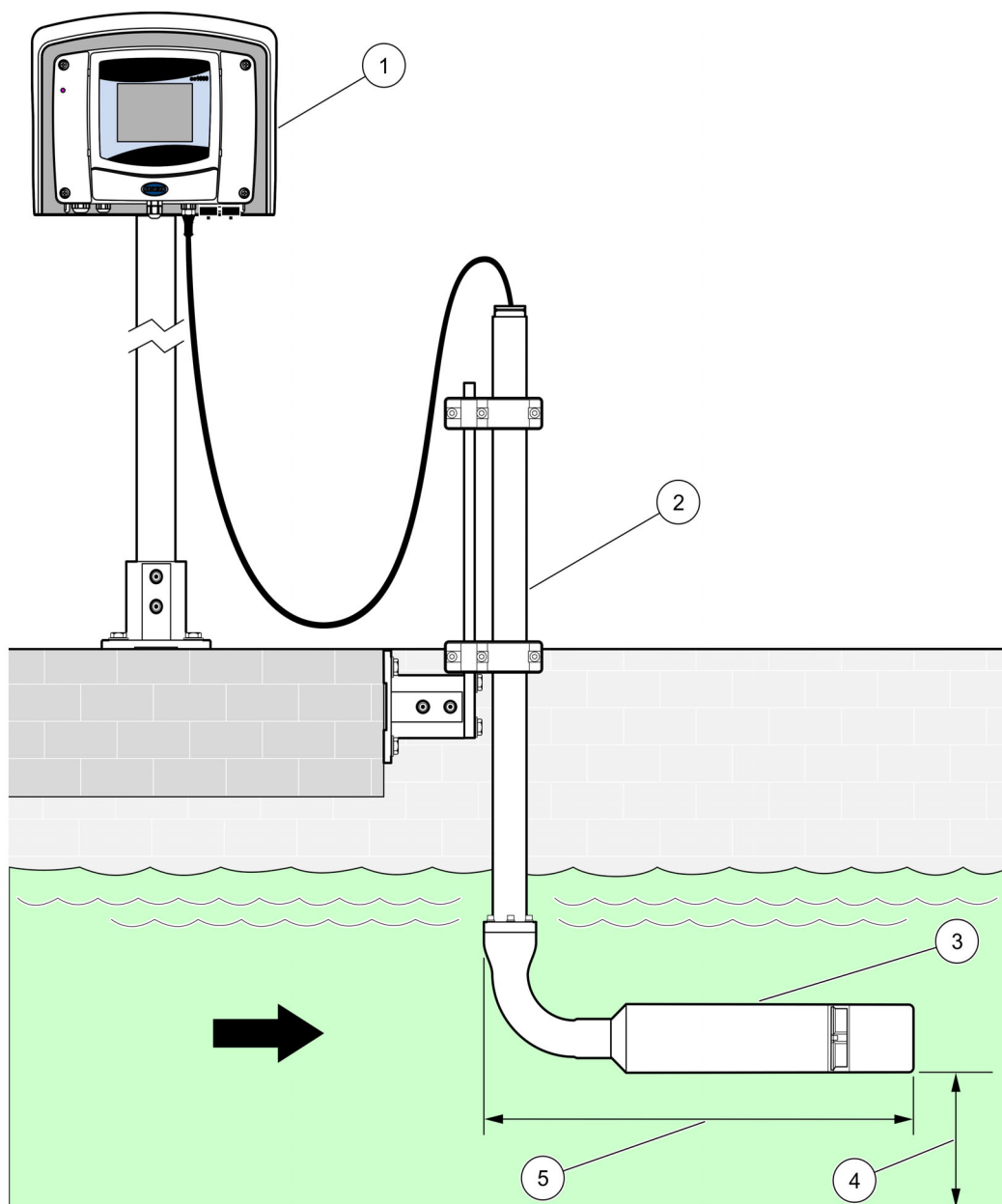

Figure 4 Installation example with optional accessories

1	sc controller with optional sun roof	4	Minimum distance of 100 mm (3.94 in.) to the ground
2	Sensor bracket	5	NITRATAX plus sc: 468–472 mm (18.4–19.6 in.) NITRATAX eco sc: 466 mm (18.3 in.) NITRATAX clear sc: 462 mm (18.1 in.)
3	NITRATAX sc sensor		

3.2 Unpack the sensor

Remove the sensor from the shipping container and inspect the sensor for damage. Verify that all items listed in [Figure 5](#) are included. If any items are missing or damaged, contact the manufacturer or distributor.

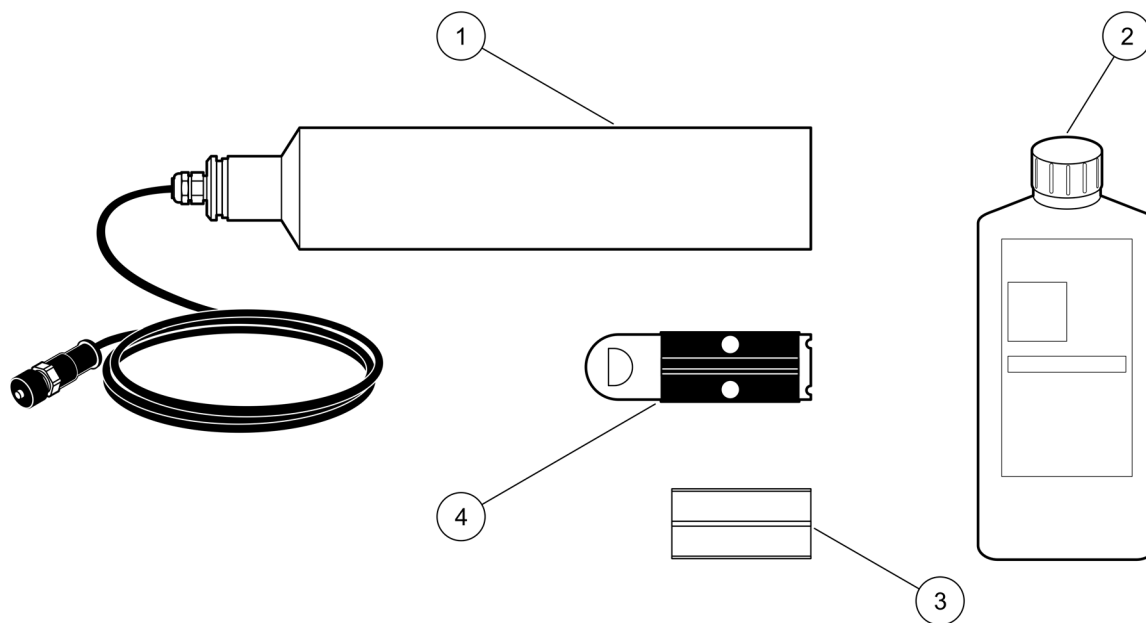

Figure 5 Items supplied

1 NITRATAX sc sensor with cable	3 1 wiper set (5 pieces) for 1 or 2 mm (0.04 in. and 0.08 in.) sensors
2 Nitrate standard solution (1 L)	4 1 wiper set (5 pieces) for 5 mm (0.20 in.) sensors

3.3 Wiring safety information

⚠ WARNING
Electrical shock hazard. Always disconnect power to the instrument when making any electrical connections.

3.4 Sensor connection and wiring

⚠ CAUTION
Before power is applied, refer to the controller operation instructions.

The sensor can be connected to any sc controller using the supplied keyed quick-connect fitting. The sensor can also be hard-wired to an sc 100 or sc 1000 controller (Refer to [Figure 7](#) for more information).

To attach the sensor to the controller with the quick-connect fitting:

1. Unscrew the protective cap on the socket on the controller ([Figure 6](#)). Retain the protective cap to seal the connector opening in case the sensor must be removed.

2. Insert the connector in the socket and hand-tighten the union nut.

Note: The middle connection of a sc1000 controller is solely reserved for the display module.

Note: Optional cables may be purchased to extend the sensor cable length (see [Section 8 on page 31](#)).

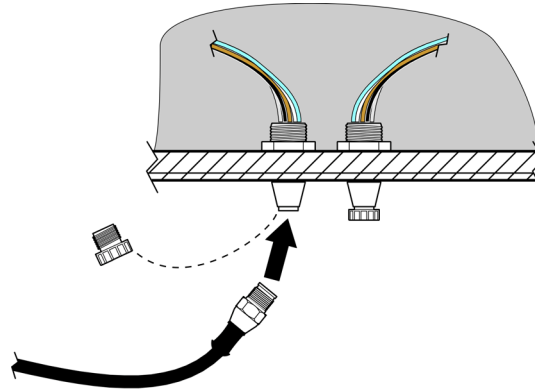

Figure 6 Attach the sensor to the controller with the quick-connect fitting

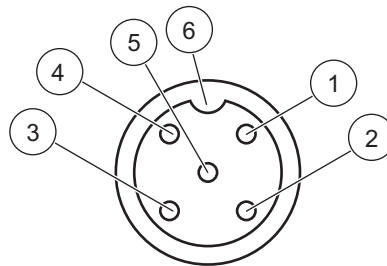

Figure 7 Sensor connector pin assignment

Terminal number	Terminal description	Wire color code
1	+12 VDC	brown
2	Mass/Circuit common	black
3	Data (+)	blue
4	Data (-)	white
5	Screen/Shield	Screen/Shield (grey)
6	Notch	—

Section 4 System Start Up

4.1 Power the instrument

1. Plug the sensor into the controller.
2. Supply power to the controller.
3. When the controller is switched on for the first time, a menu for selecting the language opens automatically. Select the required language.
4. Following language selection and upon subsequent power-up, the controller will search for connected sensors. The display will show the main measurement screen. Press the MENU key to access the menus.

5.1 Use of an sc controller

Before using the sensor in combination with an sc controller, refer to the controller user manual for navigation information.

5.2 Sensor setup

When a sensor is installed for the first time, the serial number of the sensor is displayed as the sensor name. The sensor name can be changed as follows:

1. Select MENU.
2. From the Main Menu, select SENSOR SETUP and confirm.
3. Select the appropriate sensor, if more than one sensor is attached and confirm.
4. Select CONFIGURATION and confirm.
5. Select EDIT NAME and edit the name. Confirm or cancel to return to the Configuration menu.

Use the following commands to complete the sensor configuration, see [section 5.5 on page 18](#).

- PARAMETER
- MEAS UNIT
- MEAS INTERVAL
- RESPONSE TIME
- CLEANING
- WIPER MODE
- BYPASS
- TEST/MAINT
- SET DEFAULTS

5.3 Sensor data logging

The sc controller provides a data log and an event log for each sensor. The data log contains the measured data at selected intervals. The event log contains a large number of events that occur on the instruments, such as configuration changes, alarms and warnings, etc. The data log and the event log can be exported to CSV format. The logs can be downloaded through the digital network port, service port, or the IrDA port. DataCom is needed for downloading logs to a computer. For information on downloading the logs, refer to the sc controller user manual.

The data logger of the sc100 contains the last 7000 values of the NITRATAX sc sensor. The data logger of the sc1000 can log more than 7000 values. The log interval is the same like the measuring interval of the NITRATAX sc sensor.

5.4 Sensor diagnostics menu

SELECT SENSOR STATUS>SELECT SENSOR (if more than one sensor is attached)	
ERROR LIST	Displays all actual error messages: MOIST, R < M, DEXT < 0.0, W. POS. UNKNOWN, W. BLOCKED, FLASH FAILURE, R TOO HIGH, REPLACE SHAFT SEAL, SENSOR MISSING
WARNING LIST	Displays all actual error messages: EM TOO HIGH, CONC. TOO HIGH, CHECK CALIBR., REPLACE PROFILE, SERVICE REQUIRED, REPLACE SEALS, SHAFTSEALS REPL.

Note: For more information about error messages and warnings refer to [Section 7 on page 29](#).

5.5 Sensor setup menu

SELECT SENSOR (if more than one sensor is attached)

CALIBRATE (see 5.6 on page 20)	
FACTOR	Correction factor for the measured value. Possible settings: 0.80–1.20 Default: FACTOR = 1
OFFSET	Adjustable from –250 to +250 mE for zero point correction Default: OFFSET = 0
OFFSET ADJUST	Perform a zero point calibration
1 SAMPLE CAL	Perform a single point calibration
CAL CONFIG	Select OUTPUT MODE or CAL INTERVAL
	OUTPUT MODE: Select the behavior of the outputs during calibration for zero point setting (Hold, Active, Transfer, Choice). Hold maintains the last reading prior to going into the menu. Active transmits the current level readings, corrected with previous calibration data until new data is entered. Set Transfer transmits the value designated during the system setup
	CAL INTERVAL: Enter number of days
SET CAL DEFLT	The instrument resets the settings to the default configuration.

CONFIGURATION	
EDIT NAME	Can be edited as required (up to 10 characters)
PARAMETER	NOx-N or NO3 (eco only NOx-N)
MEAS UNIT	Unit for the measured result. Possible settings: mg/l, ppm
MEAS INTERVAL	eco/clear: 5, 6, 10, 12, 15, 20, 30 min plus: 15, 20, 30 sec; 1, 2, 3, 4, 5, 6, 10, 12, 15, 20, 30 min Note: <i>Intervall of the data log is the same like the measuring intervall.</i>
RESPONSE TIME	Indication of the actual response time in Counts (count x measuring interval = response time) eco: 3–6 x MEAS INTERVAL clear: 1–6 x MEAS INTERVAL plus: 1–12 x MEAS INTERVAL Note: <i>Gliding average over 2-12 measurements.</i>
CLEANING	eco, clear: 1/MEASURE plus: 1/MEASURE; 1,2,3,5,6,10,12,15,20,30 min; 1,2,3,4,6,12 h, 10:00 h
WIPER MODE	Wiping interval. Select SINGLE or DOUBLE A-B-A or DOUBLE B-A-B SINGLE: Default setting (Default: eco) DOUBLE A-B-A: Double wiping frequency DOUBLE B-A-B: Double wiping frequency (Default: plus, clear)
BYPASS	YES/NO (plus and clear) YES: Setting for bypass application (inhibits wiper "extension")

5.5 Sensor setup menu (continued)

TEST/MAINT	Counter for customer service settings: 0–1000 days (180 days are recommended) Check the service contract and enter the defined value (number of days). 0 = Service deactivated
SET DEFAULTS	The instrument resets the settings to the default configuration. PARAMETER: eco: NO _x -N; plus, clear: NO ₃ MEAS UNIT: mg/l MEAS INTERVAL: 5 min RESPONSE TIME: eco, plus: 3 Counts; clear: 1 Count WIPER MODE: eco: SINGLE ; plus, clear: B-A-B, B-A-B

TEST/MAINT

PROBE INFO	Select NITRATAxplus/eco/clear, LOCATION, SERIAL NUMBER, RANGE, PATH LENGTH, WIPER P/N, MODEL NUMBER, SOFTWARE VERS, DRIVER VERS., PRODUCTION DATE
	Name of connected sensor: NITRATAx plus/eco/clear
	LOCATION
	SERIAL NUMBER: serial number of connected sensor
	RANGE: Measuring range corresponding to the measuring path
	PATH LENGTH: Width of the measuring path
	WIPER P/N: Item number
	MODEL NUMBER: Item number
	SOFTWARE VERS: Sensor software
	DRIVER VERS.: STRUCTURE, FIRMWARE, CONTENT
CAL DATA	Overview of OFFSET, FACTOR, DATE, DEXT 100%, DEXT 50%, DEXT 25%, CAL, R, M, IR and IM
	OFFSET: Adjustable on the CALIBRATION menu
	FACTOR: Adjustable on the CALIBRATION menu
	DATE: Date of the last change of OFFSET and/or FACTOR
	Internal calibration data: DEXT 100% DEXT 50% DEXT 25%
	CAL.: Internal calibration data
	R: Internal calibration data
	M: Internal calibration data
	IR: Internal calibration data
	IM: Internal calibration data

5.5 Sensor setup menu (continued)

COUNTERS	Overview of TOTAL TIME, PROFILE, CAL CHECK, SERVICE, SEALS, SHAFTSEAL, MOTOR and FLASH
	TOTAL TIME: Counter
	PROFILE: Counter 50000–0-negative number Note: <i>Negative if passed. Negative numbers create warning messages.</i>
	CAL CHECK: Counter xdays–0 - negative number Note: <i>Negative if passed. Negative numbers create warning messages.</i>
	SERVICE: Counter 180 days–0-negative number Note: <i>Negative if passed. Negative numbers create warning messages.</i>
	SEALS: Counter 365 days–0-negative number Note: <i>Negative if passed. Negative numbers create warning messages.</i>
	SHAFTSEAL: Counter 500000–0-negative number Note: <i>Negative if passed. Negative numbers create warning messages.</i>
	MOTOR: Counter
	FLASH: Counter
MAINT. PROC.	Select REPLACE PROFILE, SERVICE DONE, WIPERTEST, SIGNALS or OUTPUT MODE
	REPLACE PROFILE: see 6.3 on page 25
	SERVICE DONE: ARE YOU SURE? Confirm or press BACK key Confirm: The instrument resets the settings after a prompt confirmation to the default configuration. Press BACK key to return to the MAINT. PROC. menu.
	WIPERTEST: Select WIPE or DRIVE OUT WIPER or MOTOR CURRENT. WIPE: Wiping process DRIVE OUT WIPER: Wiper profile extends, on flow-through versions inhibited (see 6.2 on page 24) MOTOR CURRENT: Measurement during the wiping process (motor current < 100 mA)
	SIGNALS: ENTER = WIPE: Confirm. Average value: target: < 100 mA Individual measured value = displayed value Single measured value for AQA (FACTOR = 1, OFFSET = 0) W.POS (wiper position) DEXT (delta extinction between EM and ER) EM (extinction measuring channel) ER (extinction reference channel) M (measured level) R (reference level) IM (intensity measuring channel) IR (intensity reference channel) MOIST
	OUTPUT MODE: Select ACTIVE or HOLD or TRANSFER or CHOICE

5.6 Sensor calibration

1. Select MENU.
2. From the Main Menu, select SENSOR SETUP and confirm.
3. Select the appropriate sensor, if more than one sensor is attached and confirm.
4. Select CALIBRATE and confirm.

5. Close the hole of the back of the measuring path of 2 and 5 mm sensors with a sticky tape that filled water cannot flow out.
 6. Select OFFSET ADJUST and confirm.
 7. Confirm the displayed OUTPUT MODE information.
 8. FILL IN AQUA DEST PRESS ENTER TO CONTINUE is displayed. Remove the sensor from the tank and the rinse measuring path with distilled water. Align the measuring path horizontally and completely fill with distilled water. Confirm.
 9. PRESS ENTER WHEN STABLE, CONC. X.X mg/l NO₃, DEXT X.X mE is displayed. Confirm when a stable value is reached.
 10. Select WIPE. Wiping process occurs.
 11. PRESS ENTER WHEN STABLE , CONC. X.X mg/l NO₃, DEXT X.X mE is displayed. Add distilled water until the measured value is stable and confirm.
 12. Select CALIBRATE and confirm.
 13. COMPLETE OFFSET X.X mE is displayed. Confirm.
 14. PRESS ENTER WHEN STABLE, CONC. X.X mg/l NO₃, DEXT X.X mE is displayed. Confirm when a stable value is reached.
 15. Select COMPLETE and confirm.
 16. Select 1 SAMPLE CAL and confirm.
 17. FILL IN STANDARD PRESS ENTER TO CONTINUE is displayed. Select Option 1 or Option 2:
 - **Option 1:** Insert the verification filter now to calibrate.
 - **Option 2:** Adjust the sensor calibration using a standard solution (or a user-specific measuring solution) and laboratory spectrophotometer.Confirm.
 18. PRESS ENTER WHEN STABLE, CONC. X.X mg/l NO₃, DEXT X.X mE is displayed. Note the mE value if working with the sample and confirm.
 19. Select CALIBRATE. Adjust the XX.X mE value of the filter or sample from the previously noted value and confirm.
 20. Confirm COMPLETE FACTOR and the factor will be adjusted automatically.
 21. PRESS ENTER WHEN STABLE, X.X mg/l NO₃, X.X mE is displayed.
 - **Option 1:** Completed after confirming. If this message is not displayed and Option 1 was chosen, clean the lens and repeat.
 - **Option 2:** Continue with the following steps.
 22. Select WIPE and confirm.
 23. PRESS ENTER WHEN STABLE, X.X mg/l NO₃, X.X mE is displayed.
 24. Check the values. Confirm when the mE value is close to noted previous one. Option 2 is now completed.
 25. Select COMPLETE and confirm.
- Note: Only NITRATAXeco has a one point calibration which influences the offset.*
26. The sensor calibration is completed.

5.6.1 Adjusting turbidity compensation

1. Take a sample of activated sludge at the measuring location after the first half of the aeration phase. Immediately after sampling approximately 100 mL, filter the sample using a folded filter.
2. Similar to a standard solution, pour the filtrate into the measuring path of the sensor. As an alternative, the measured value can also be determined by a laboratory measurement (for $\text{NO}_2\text{-N}$ and $\text{NO}_3\text{-N}$).
3. Select 1 SAMPLE CAL and measure the filtered sample.
4. Turn the wiper on and add sample until the measured value is stable.
5. Immerse the sensor in the activated sludge tank.
6. Start the wiper several times until a stable result is obtained for the activated sludge. Add the difference $mE_{\text{filtered}} - mE_{\text{aeration}}$ to the adjusted offset value.

Section 6 Maintenance

⚠ CAUTION

Pinch Hazard. Only qualified personnel should conduct the tasks described in this section of the manual.

Important Note: Proper maintenance of the measuring windows in the sensor is critical for accurate measurements. The measuring windows should be checked monthly for soiling and the wiper profile checked for wear.

NOTICE

The seals must be replaced by the manufacturer's Service Department. For more information, see the instruction sheet of the flow-through accessories for NITRATAX sc.

6.1 Maintenance schedule

Maintenance Task	weekly	6 months	Annually	as per counter
Visual inspection	X			
Check calibration	X (depending on the ambient conditions)			
Inspection		X (counter)		
Seal change			X (counter)	
Wiper profile change				X

Wearing parts		
Quantity	Description	Average service life ¹
1	Wiper sets	1 year
1	Wiper motor	5 years
1	Seal set	1 year
1	Light bulb	10 years
2	Measuring window	5 years
1	Filter set	5 years
2	O-ring flow unit	1 year

¹ Under normal operating conditions using factory settings.

6.2 Clean the measuring path

DANGER

Potential danger with contact with chemical/biological substances.
Working with chemical samples, standards and reagents can be dangerous.
Make yourself familiar with the necessary safety procedures and the correct handling of the chemicals before use and read and follow all relevant safety data sheets.

Normal operation of this device may require the use of chemicals or samples that are biologically unsafe.

- Observe all cautionary information printed on the original solution containers and safety data sheets prior to their use.
- Dispose of all consumed solutions in accordance with the local and national regulations and laws.
- Select the type of protective equipment suitable to the concentration and quantity of the dangerous material being used.

Additional cleaning of the measuring path is not necessary if the wiper interval is set for the appropriate application and the wiper profile is replaced regularly.

To clean the measuring path:

1. Select MENU.
2. From the Main Menu, select SENSOR SETUP and confirm.
3. Select the appropriate sensor, if more than one sensor is attached and confirm.
4. Select TEST/MAINT and confirm.
5. Select MAINT.PROC. and confirm.
6. Confirm the displayed OUTPUT MODE information.
7. Select SIGNALS and confirm.
8. Confirm ENTER = WIPE.
9. Remove sensor from the tank. Depending on the degree and nature of the soiling, clean measuring path using window cleaner, grease remover or 5 % hydrochloric acid (the operation of the wiper arm using [WIPERTEST], [WIPE] can assist the cleaning process).
10. Soak for 5–10 minutes, then carefully clean the measuring path with distilled water.
Objective: [ER] and [EM] < 500
11. Press BACK to return to MAINT.PROC.
12. Press BACK again. Confirm RETURN PROBE TO PROCESS (Measuring operation after automatic wiping).
13. The cleaning of the measuring path is completed.

6.3 Change the wiper profile

⚠ CAUTION

Obey the locally applicable accident prevention regulations. Wear protective gloves where necessary during the change of the wiper rubber.

Refer to [Figure 8](#) and the following steps to change the wiper profile.

Note: First remove the sensor out of the flow-through unit until the wiper can be extended without resistance.

For this purpose on the menu set SENSOR SETUP>CONFIGURATION>BYPASS to "NO". For more information about the flow-through unit refer to the instruction sheet of the flow-through accessories for NITRATAX sc.

1. Select MENU.
2. From the Main Menu, select SENSOR SETUP and confirm.
3. Select the appropriate sensor, if more than one sensor is attached and confirm.
4. Select TEST/MAINT and confirm.
5. Select MAINT.PROC. and confirm.
6. Remove the sensor out of the basin.

Note: For disassembly the sensor from the flow-through unit, refer to the instruction sheet of the flow-through accessories for NITRATAX sc.

7. Confirm the displayed OUTPUT MODE information.
8. Select REPLACE PROFILE and confirm.
9. Lift the retaining strap ([Figure 8](#), item 1), move the cap bottom up and remove it ([Figure 8](#), item 2 and 3).
10. Confirm REMOVE CAP!

Note: Only on instrument versions with 1 or 2 mm measuring path.

11. The wiper extends automatically. Exchange the wiper profile ([Figure 8](#), item 4) and replace the cap to lock in place ([Figure 8](#), item 5).
12. Confirm REPLACE PROFILE! PUT ON CAP!

Note: Only on instrument versions with 1 or 2 mm measuring path.

13. Press BACK.
14. Remove the sensor back to the tank or install it in the flow-through unit. If necessary adjust "YES" for the flow-through unit in the configuration menu.
15. Confirm RETURN PROBE TO PROCESS (Measuring operation after automatic wiping).
16. The exchange of the wiper profile is completed.

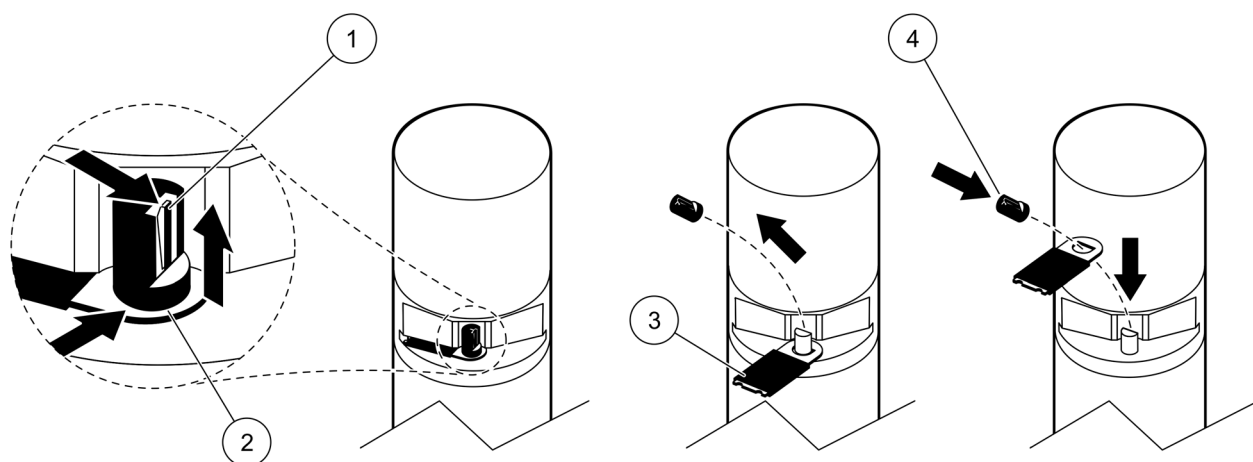

Figure 8 Changing wiper profile

1 Retaining strap	3 Wiper profile
2 Cap bottom	4 Locking the wiper and cap in place

6.4 Check the calibration

The NITRATAX sc program supports comparative measurements as part of Analytical Quality Assurance (AQA) using a command that automatically sets the factor to "1" and the offset to "0" so that standard solutions can be measured directly without further adjustments.

1. Select MENU.
2. From the Main Menu, select SENSOR SETUP and confirm.
3. Select the appropriate sensor, if more than one sensor is attached and confirm.
4. Select TEST/MAINT and confirm.
5. Select MAINT.PROC. and confirm.
6. Confirm the displayed OUTPUT MODE information.
7. Select SIGNALS and confirm.
8. Confirm ENTER = WIPE.
9. **Tank version:** Remove sensor from the tank, rinse the measuring path with water and fill it with standard solution (pipette), see [Figure 9 on page 27](#).
Flow-through version: Interrupt sample feed and supply with standard solution (syringe).

Observe the individual measured values on the display (3rd numerical value from the top). The measurements are made automatically at an interval of 1 second. Then re-install the sensor or connect sample feed.

10. Press BACK to return to MAINT.PROC.
11. Press BACK again. Confirm RETURN PROBE TO PROCESS (Measuring operation after automatic wiping).
12. The calibration check is completed.

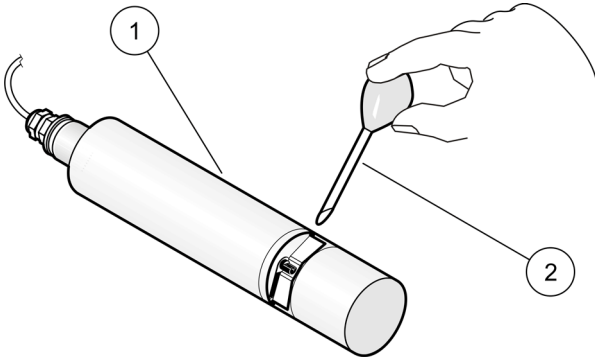

Figure 9 Check the calibration (tank version)

1 NITRATAX sc	2 Pipette with standard solution
---------------	----------------------------------

Section 7 Troubleshooting

7.1 Error messages

When the sensor is experiencing an error condition, the sensor reading on the measurement screen will flash and the relays and outputs associated with this sensor will be held. Errors are defined in [Table 1](#).

From the Main Menu, select SENSOR STATUS and confirm to determine the cause of the fault.

Table 1 Error messages

Error Displayed	Solution
NONE	—
MOIST	Check MOIST value on the SENSOR-SETUP menu >TEST/MAINT>MAINT. PROC.> SIGNALS>MOIST Remove sensor from the tank and call service
R < M	Call service
DEXT < 0.0	Complete a Zero point calibration
W. POS. UNKNOWN	Check measuring path, complete a wiper test
W. BLOCKED	Check measuring path, complete a wiper test
FLASH FAILURE	Call service
R TOO HIGH	Call service
Wiper sealing	Call service, the wiper is deactivated
Sensor is missing	Prove connection

7.2 Warnings

A sensor warning will leave all menus, relays and outputs functioning normally, but will cause a warning icon to flash.

Warnings may be used to trigger a relay and users can set warning levels to define the severity. Warnings are defined in [Table 2](#).

From the Main Menu, select SENSOR STATUS and confirm to determine the cause of the fault.

Table 2 Warnings

Warning displayed	Cause	Solution
NONE	Correct measuring operation	—
EM TOO HIGH	Turbidity, organic content or nitrate concentration too high, measuring range exceeded as a result	Check measurement in the laboratory
CONC. TOO HIGH	Nitrate concentration too high, as a result measuring range exceeded	Check measurement in the laboratory
CHECK CALIBR.	Test interval elapsed	Check calibration
REPLACE PROFILE	Counter elapsed	Change wiper profile
SERVICE REQUIRED	Counter elapsed	Call service
REPLACE SEALS	Counter elapsed	Call service
SHAFTSEALS REPL.	Counter elapsed	Call service
Inspection necessary	Counter elapsed	Call service

Section 8 Replacement Parts and Accessories

8.1 Replacement parts

Description	Catalog Number
NITRATAx plus sc (1 mm/0.04 in.)	LXV417.99.10002
NITRATAx plus sc (2 mm/0.08 in.)	LXV417.99.20002
NITRATAx plus sc (5 mm/0.20 in.)	LXV417.99.50002
NITRATAx clear sc (5 mm/0.20 in.)	LXV420.99.50002
NITRATAx eco sc	LXV415.99.10002
User Manual	DOC023.54.03211

8.2 Accessories

Description	Catalog Number
Cable extension set 5 m (16.4 ft)	LZX848
Cable extension set 10 m (32.81 ft)	LZX849
Cable extension set 15 m (49.21 ft)	LZX850
Cable extension set 20 m (65.62 ft)	LZX851
Cable extension set 30 m (98.43 ft)	LZX852
Cable extension set 50 m (164.04 ft)	LZX853
Cable extension set 100 m (328.08 ft)	LZY339
Sensor bracket with 90° adapter	LZY714.99.53220
Includes:	
Base	LZY827
Fastening lug	LZY804
Retaining clamp (2x)	LZX200
Mounting pipe 2 m	LZY714.99.00020
Hardware HS	LZY823
90° sensor adapter	LZY714.99.50000
Set of small parts for mounting hardware	LZY822
Extension pipe 1.8 m (5.91 ft)	LZY714.99.00030
Extension pipe 1.0 m (3.28 ft)	LZY714.99.00040
Second fastening point (with retaining clamp)	LZY714.99.03000
Flow-through unit for NITRATAx plus sc (2 mm/0.08 in.)	LZX869
Flow-through unit for NITRATAx plus sc (5 mm/0.20 in.)	LZX867
Flow-through unit for NITRATAx clear sc (5 mm/0.20 in.)	LZX866
Spare sealings	LZX428
Tubing set	LZX407
Allen key with setscrew	LZX875
Sealing set for flow-through unit	LZX572
Control standard 25 mg/L NO ₃ (5.56 mg/L NO ₃ -N)	LCW828
Control standard 50 mg/L NO ₃ (11.3 mg/L NO ₃ -N)	LCW825
Control standard 100 mg/L NO ₃ (22.6 mg/L NO ₃ -N)	LCW826
Control standard 200 mg/L NO ₃ (45.2 mg/L NO ₃ -N)	LCW827
Control standard 400 mg/L NO ₃ (90.4 mg/L NO ₃ -N)	LCW863

8.3 Wearing parts

Description	Catalog Number
Wiper profile (1 mm/0.04 in.) (5 pieces)	LZX148
Wiper profile (2 mm/0.08 in.) (5 pieces)	LZX012
Wiper profile (5 mm/0.20 in.) (5 pieces)	LZX117

Section 9 Limited Warranty

The manufacturer warrants its products to the original purchaser against any defects that are due to faulty material or workmanship for a period of one year from date of shipment unless otherwise noted in the product manual.

In the event that a defect is discovered during the warranty period, the manufacturer agrees that, at its option, it will repair or replace the defective product or refund the purchase price excluding original shipping and handling charges. Any product repaired or replaced under this warranty will be warranted only for the remainder of the original product warranty period.

This warranty does not apply to consumable products such as chemical reagents; or consumable components of a product, such as, but not limited to, lamps and tubing.

Contact the manufacturer or your distributor to initiate warranty support. Products may not be returned without authorization from the manufacturer.

Limitations

This warranty does not cover:

- Damage caused by acts of God, natural disaster, labor unrest, acts of war (declared or undeclared), terrorism, civil strife or acts of any governmental jurisdiction
- Damage caused by misuse, neglect, accident or improper application or installation
- Damage caused by any repair or attempted repair not authorized by Hach Company
- Any product not used in accordance with the instructions furnished by Hach Company
- Freight charges to return merchandise to Hach Company
- Freight charges on expedited or express shipment of warranted parts or product
- Travel fees associated with on-site warranty repair

This warranty contains the sole express warranty made by the manufacturer in connection with its products. All implied warranties, including without limitation, the warranties of merchantability and fitness for a particular purpose, are expressly disclaimed.

Some states within the United States do not allow the disclaimer of implied warranties and if this is true in your state the above limitation may not apply to you. This warranty gives you specific rights, and you may also have other rights that vary from state to state.

This warranty constitutes the final, complete, and exclusive statement of warranty terms and no person is authorized to make any other warranties or representations on behalf of the manufacturer.

Limitation of Remedies

The remedies of repair, replacement or refund of purchase price as stated above are the exclusive remedies for the breach of this warranty. On the basis of strict liability or under any other legal theory, in no event shall the manufacturer be liable for any incidental or consequential damages of any kind for breach of warranty or negligence.

Table 3 Sensor Modbus Registers

Group Name	Register #	Data Type	Length	R/W	Description
measurement	40001	Float	2	R	diplayed measurement value
unit	40003	Unsigned Integer	1	R/W	unit : mg/l = 0 : g/l = 1
parameter	40004	Unsigned Integer	1	R/W	parameter
Measure interval	40005	Unsigned Integer	1	R/W	measuring interval
correction	40006	Float	2	R/W	correction
offset	40008	Float	2	R/W	offset
integration	40010	Unsigned Integer	1	R/W	integration, always 1
cleaning_interval	40011	Unsigned Integer	1	R/W	cleaning interval
wiper mode	40012	Unsigned Integer	1	R/W	wiper mode
wiper state	40013	Unsigned Integer	1	R/W	wiper state
resp time	40014	Unsigned Integer	1	R/W	response time
drv_struct_ver	40015	Unsigned Integer	1	R	driver structure version
drv_firmw_ver	40016	Unsigned Integer	1	R	driver firmware version
drv_cont_ver	40017	Unsigned Integer	1	R	driver content version
location	40018	String	5	R/W	location
path length	40023	Float	2	R	path length
profile	40025	Integer	2	R	profile counter
motor_cycles	40027	Integer	2	R	motor cycles
flash_counter	40029	Integer	2	R	flash counter
sealing_counter	40031	Integer	2	R	sealing counter
service_counter	40033	Integer	2	R	service counter
operating_hours	40035	Integer	2	R	operating hours
shaft_sealing_counter	40037	Integer	2	R	shaft sealing counter
profile reset val	40039	Integer	2	R/W	profile reset val
seals reset val	40041	Integer	2	R/W	seals reset val
service reset val	40043	Integer	2	R/W	service reset val
shaft seal reset val	40045	Integer	2	R/W	shaft seal reset val
des_measurement	40047	Float	2	R	desired measurement value
meas_single_value	40049	Float	2	R	measurement single value
dext	40051	Float	2	R	delta extinction
EM	40053	Float	2	R	m - extinction
ER	40055	Float	2	R	r - extinction
M	40057	Float	2	R	m
R	40059	Float	2	R	r
intensity_mes	40061	Float	2	R	m - intensity
intensity_ref	40063	Float	2	R	r - intensity
humidity_main	40065	Float	2	R	humidity - main
conc_blank	40067	Float	2	R	concentration whithout correction
cal_date	40069	Time	2	R	calibration time and date
user_cal_date	40071	Time	2	R	user calibration time and date
std_s3	40073	Float	2	R	standard S3
cal_L1	40075	Float	2	R	cal. point 1

Modbus Register Information

Table 3 Sensor Modbus Registers (continued)

cal_L2	40077	Float	2	R	cal. point 2
cal_L3	40079	Float	2	R	cal. point 3
cal_mes	40081	Float	2	R	m - calibration
cal_ref	40083	Float	2	R	r - calibration
cal_intensity_mes	40085	Float	2	R	intensity m - calibration
cal_intensity_ref	40087	Float	2	R	intensity r - calibration
cal_ext	40089	Float	2	R	extinction - calibration
process	40091	Unsigned Integer	1	R/W	process register
menu	40092	Unsigned Integer	1	R	menu state
gain_ref	40093	Integer	1	R	low byte = gain ref-channel, high byte = second cap. on/off
gain_mes	40094	Integer	1	R	low byte = gain mes-channel, high byte = second cap. on/off
wiper_lim_a	40095	Integer	1	R	wiper limit a
wiper_lim_b	40096	Integer	1	R	wiper limit b
wiper_lim_out	40097	Integer	1	R	wiper limit out
prg_vers	40098	String	4	R	program version
ser_no	40102	Integer	2	R	serial number
cal_out_cfg	40104	Integer	1	R	cal. Output mode
user_cal_int	40105	Integer	1	R/W	user calibration interval
wiper_current	40106	Integer	1	R	wiper motor current in mA
resp_time_min	40107	Integer	1	R	response time in min
flash_per_fil	40108	Integer	2	R	flash per filter
cm1	40110	Float	2	R/W	meas. Cap 1
cm2	40112	Float	2	R/W	meas cap 2
cr1	40114	Float	2	R/W	ref cap1
cr2	40116	Float	2	R/W	ref cap2
lambda_m	40118	Float	2	R/W	lambda meas
lambda_r	40120	Float	2	R/W	lambda ref
transm_m	40122	Float	2	R/W	transmission meas
transm_r	40124	Float	2	R/W	ransmission ref
cal_menu	40126	Unsigned Integer	1	R/W	cal menu
wiper_menu	40127	Unsigned Integer	1	R/W	wiper menu
maint_menu	40128	Unsigned Integer	1	R/W	maint_menu
service_menu	40129	Unsigned Integer	1	R/W	service menu
flash_repl	40130	Unsigned Integer	1	R/W	flash replaced question
edit_menu	40131	Unsigned Integer	1	R/W	edit menu
def_menu	40132	Unsigned Integer	1	R/W	default menu
filter_data_menu	40133	Unsigned Integer	1	R/W	filter data menu
prod_date	40134	Time	2	R	production date
sensor_type	40136	String	8	R/W	sensor type
filter_set	40144	String	3	R/W	filter set
user_cal_counter	40147	Integer	1	R	user cal. Counter
pos_out_en	40148	Unsigned Integer	1	R/W	pos. Out enable

A		S	
Accessories	31	Sensor	
C		Calibration	20
Calibration	20	Diagnostics menu	18
Check up	26	overview	9
Cleaning		Sensor setup	17
Measuring path	24	Specifications	3
D		T	
Data logging	17	Theory of operation	10
Dimensions	3, 5	Troubleshooting	29
E		Turbidity compensation	22
Error Messages	29	U	
I		Unpacking	12
Installation	11	W	
M		Warnings	29
Maintenance	23	Warranty	33
Maintenance Schedule	23	Wear part	32
Modbus	35	Weight	3, 4
P		Wiper profile	25
Pin assignment	13		

HACH COMPANY World Headquarters

P.O. Box 389, Loveland, CO 80539-0389 U.S.A.
Tel. (970) 669-3050
(800) 227-4224 (U.S.A. only)
Fax (970) 669-2932
orders@hach.com
www.hach.com

HACH LANGE GMBH

Willstätterstraße 11
D-40549 Düsseldorf, Germany
Tel. +49 (0) 2 11 52 88-320
Fax +49 (0) 2 11 52 88-210
info-de@hach.com
www.de.hach.com

HACH LANGE Sàrl

6, route de Compois
1222 Vérenaz
SWITZERLAND
Tel. +41 22 594 6400
Fax +41 22 594 6499

