



DOC023.54.03230

UVAS sc

User Manual

1/2023 Edition 5

Table of Contents

Section 1 Specifications	5
Section 2 General information	7
2.1 Safety information.....	7
2.1.1 Hazard information in this manual	7
2.1.2 Warning labels	7
2.2 Applications	8
2.3 Measuring principle	8
Section 3 Installation	11
3.1 Installation overview	11
3.2 Sensor	12
3.3 Attaching the Sensorcable.....	15
3.4 Wiring safety information	15
3.4.1 Sensor connection and wiring.....	16
Section 4 Operation	17
4.1 sc controller operation	17
4.2 Sensor setup	17
4.3 Sensor data logger	17
4.4 Menu structure.....	18
4.4.1 SENSOR STATUS.....	18
4.4.2 SENSOR setup	18
4.5 Calibration	22
4.5.1 Verifying	22
4.5.2 Zero point calibration	23
4.5.3 1 point calibration	23
4.6 Adjusting measured values	24
4.6.1 Zero point adjustment	24
4.6.2 Setting factor	24
4.7 Conversion into other total parameters	25
Section 5 Maintenance	27
5.1 Maintenance schedule.....	27
5.2 Cleaning measuring path.....	28
5.3 Changing wiper profile.....	29
5.4 Seal change (bypass version)	30
5.4.1 UVAS plus sc	30
Section 6 Troubleshooting	31
6.1 Error messages	31
6.2 Warnings	31
Section 7 Replacement Parts	33
Appendix A ModBUS Register Information	35

Specifications are subject to change without notice.

The product has only the approvals listed and the registrations, certificates and declarations officially provided with the product. The usage of this product in an application for which it is not permitted is not approved by the manufacturer.

Table 1 UVAS *plus* sc tank sensors

	UVAS <i>plus</i> sc
Measuring technique	UV absorption measurement (2-beam technique), reagent-free
Measuring method	SAC 254 in accordance with DIN 38404 C3
Measuring path	1, 2, 5 and 50 mm
Measuring range	0.01-60 m ⁻¹ (50 mm) 0.1-600 m ⁻¹ (5 mm) 0-1500 m ⁻¹ (2 mm) 2-3000 m ⁻¹ (1 mm) Can be calibrated to the total parameter COD depending on the application
Compensation	550 nm
Measuring interval (≥ min)	≥1 min
Cable length	10 m (33 ft) standard Optional extension cables available in 5, 10, 15, 20, 30, 50 m Total maximum length: 60 m (196 ft)
Control function	PID, time control, 2-point controller
Probe pressure limit	max. 0.5 bar
Ambient temperature	+2 °C to +40 °C
Dimensions D × L	Approx. 70 mm x 333 mm
Mass	approx. 3.6 kg
Inspection interval	6 months
User maintenance	1 h / month, typical

Table 2 UVAS *plus* sc bypass sensors

	UVAS <i>plus</i> sc (in the bypass)
Measuring path	2, 5 and 50 mm
Measuring range With NO₃-N standard solutions	0.01-60 m ⁻¹ (50 mm) 0.1-600 m ⁻¹ (5 mm) 0-1500 m ⁻¹ (2 mm) Can be calibrated to the total parameter COD depending on the application
Cable length	10 m (33 ft) standard Optional extension cables available in 5, 10, 15, 20, 30, 50 m Total maximum length: 60 m (196 ft)
Sample flow rate	At least 0.5 L/h sample
Pressure limit	max. 0.5 bar
Sample connection	Hose ID 4 mm / OD 6 mm

Specifications

Sample temperature	+2 °C to +40 °C
Dimensions	see Figure 4, page 14
Warranty	2 years

Table 3 UVAS *plus* sc sensor-material

Component	Material
Probe probehousing wiper axis fitting profile joist 2 mm wiperarm 5 mm / 50 mm	stainless steel 1.4571 stainless steel 1.4571 stainless steel 1.4305 stainless steel 1.4310 stainless steel 1.4581
Wiper Profile measuring window seal for housing seal for fitting probe cable	silicone SUPRASIL (silica glass) silicone PVDF SEMOFLEX (PUR)
Leverage probe adapter leverage	stainless steel 1.4308 stainless steel 1.4301
Bypass measuring cell seals fittings tube	PVC EPDM PVDF PVC

2.1 Safety information

Please read this entire manual before unpacking, setting up, or operating this equipment. Pay attention to all danger and caution statements. Failure to do so could result in serious injury to the operator or damage to the equipment.

To prevent any impairment of the instrument's safety features, it must not be used or installed in any manner other than that specified in this manual.

⚠ DANGER
Do not use the probe in hazardous area.

2.1.1 Hazard information in this manual

⚠ DANGER
Indicates a potentially or imminently hazardous situation which, if not avoided, will result in death or serious injury.

⚠ WARNING
Indicates a potentially or imminently hazardous situation which, if not avoided, could result in death or serious injury.



⚠ CAUTION
Indicates a potentially hazardous situation that may result in minor or moderate injury.

NOTICE
Indicates a situation which, if not avoided, may cause damage to the instrument. Information that requires special emphasis.



Note: Information that supplements points in the main text.

2.1.2 Warning labels

Read all labels and notices attached to the equipment. Personal injury or damage to the equipment could occur if they are not observed. Any symbol on the equipment will appear along with a caution statement in the manual.

	This symbol, if noted on the instrument, references the user manual for operation and/or safety information.
	This symbol, when noted on a product enclosure or barrier, indicates that a risk of electrical shock and/or electrocution exists.
	This symbol may appear on the product and indicates the need for protective eye wear.

General information

	<p>This symbol may appear on the product and identifies the connection point for the protective ground.</p>
	<p>When this symbol appears on the product, it identifies the location of a fuse or a current limiter.</p>
	<p>Electrical equipment marked with this symbol may not be disposed of in European domestic or public disposal systems. Return old or end-of-life equipment to the manufacturer for disposal at no charge to the user.</p>

2.2 Applications

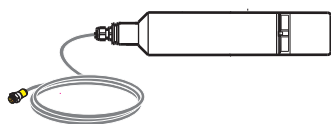

UVAS *plus sc*:

immersed directly in the medium, without pumping or preparation of a sample, the sensor measures the content of dissolved organic compounds in activated sludge tanks in municipal sewage treatment plants, surface water, untreated water and treated drinking water. The system can also be used for checking the outlet of waste water treatment plants.

Bypass accessories for UVAS *plus sc*:

the through-flow variant of the high-precision UVAS *plus sc* sensor is used wherever direct measurement in the medium is not possible for construction-related reasons or the medium load makes it necessary to measure a filtered sample (very high TS contents, sewage treatment plant inlet, waste dump seepage,...).

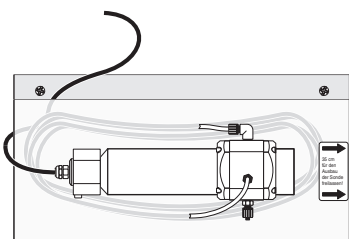

NOTICE

Any use other than use in accordance with requirements defined in the user manual leads to the loss of the warranty claims and can lead to personal injury and property damage, for which the manufacturer assumes no liability.

2.3 Measuring principle

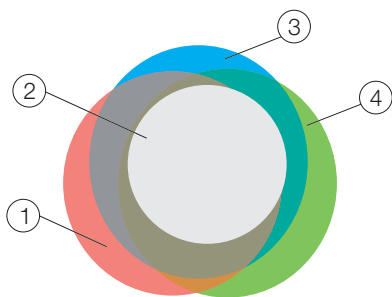

Substance groups measured

1. COD	3. SAC
2. BOD	4. TOC

Organic compounds dissolved in water in general absorb UV light, for this reason the measurement of UV absorption represents an independent total parameter for dissolved organic substance water load. In drinking water treatment this method of determination of the quality of water without chemicals using laboratory photometers and filtered samples has a long tradition.

DIN 38402 C2 stipulates for the measurement of the UV absorption, the measuring wavelength of 254 nm and characterises the measured value for a filtered sample as a spectral absorption coefficient at 254 nm (SAC254 for short), which is to be converted to extinctions per metre. In this way straightforward comparability of the measured results from photometers with different cuvette intensities is achieved and the units 1/m or m⁻¹ are obtained.

The UVAS immersed probe comprises a multiple beam absorption photometer with effective turbidity compensation. The related controller controls the process of the measurement using a flash lamp photometer, the mechanical cleaning of the measuring window by a wiper, and also displays the measured values as SAC254 in 1/m.

For other total parameters such as COD or TOC etc. there is a correlation for the SAC254 of the same quality as, e.g., between COD and TOC. Very high availability of measured values, minimum investment, minimum effort for installation and maintenance or upkeep are therefore often key reasons for the

decision in favour of the UVAS sensor if an online measurement is to be used for a total parameter.

For media containing solids, the SAC measurement with UVAS should always be supplemented with a solids or turbidity measurement (SOLITAX sc, ULTRATURB sc).

The maintenance effort for the user is minimal and is limited to a straightforward inspection that, depending on the medium, is due at the most weekly.

3.1 Installation overview

⚠ CAUTION
Installation of this system may only be carried out by qualified experts in accordance with all local safety regulations. See the mounting instruction sheet for more information.

Figure 1 Installation example with optional accessories

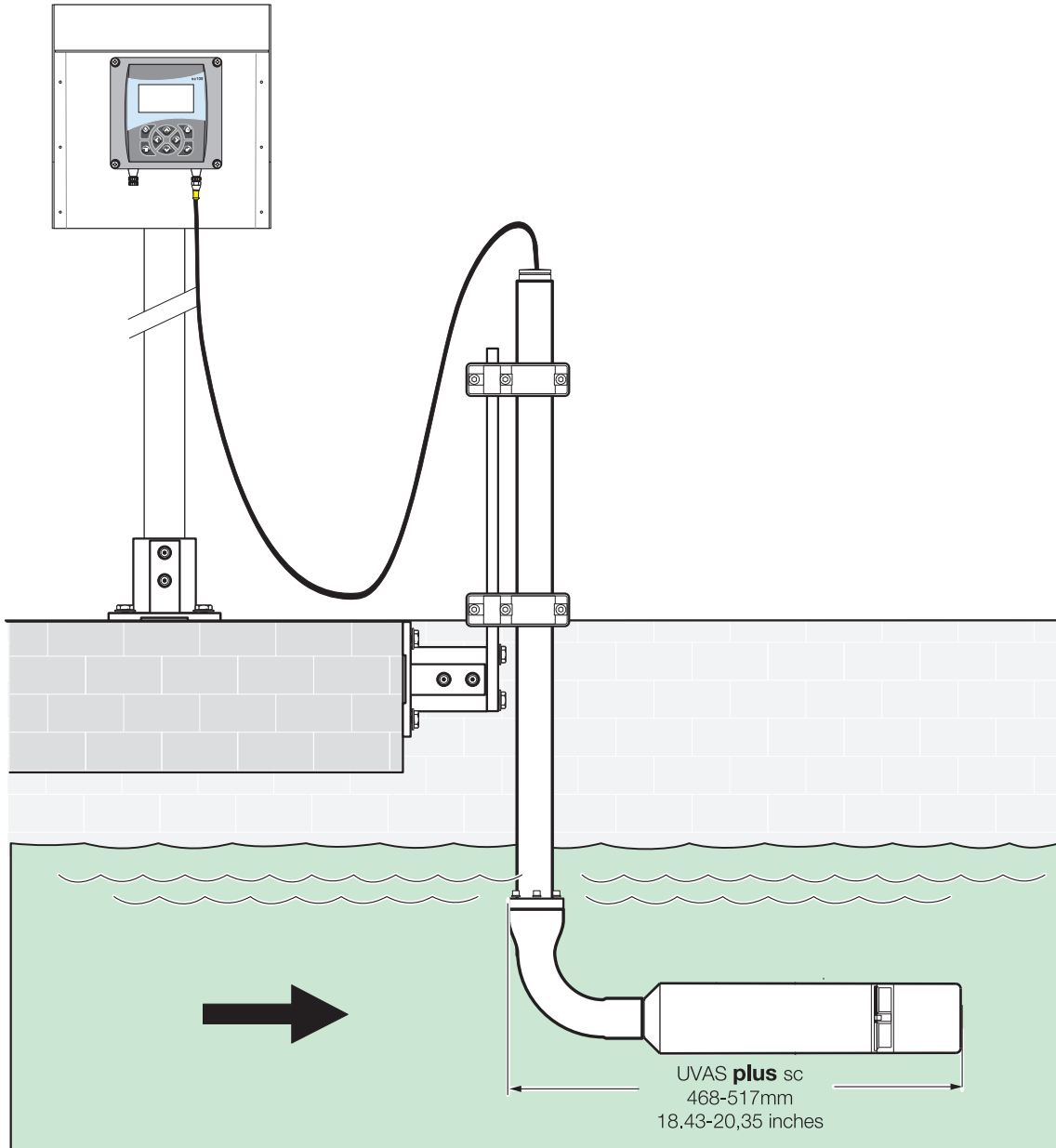

3.2 Sensor

Figure 2 Sensor accessory components

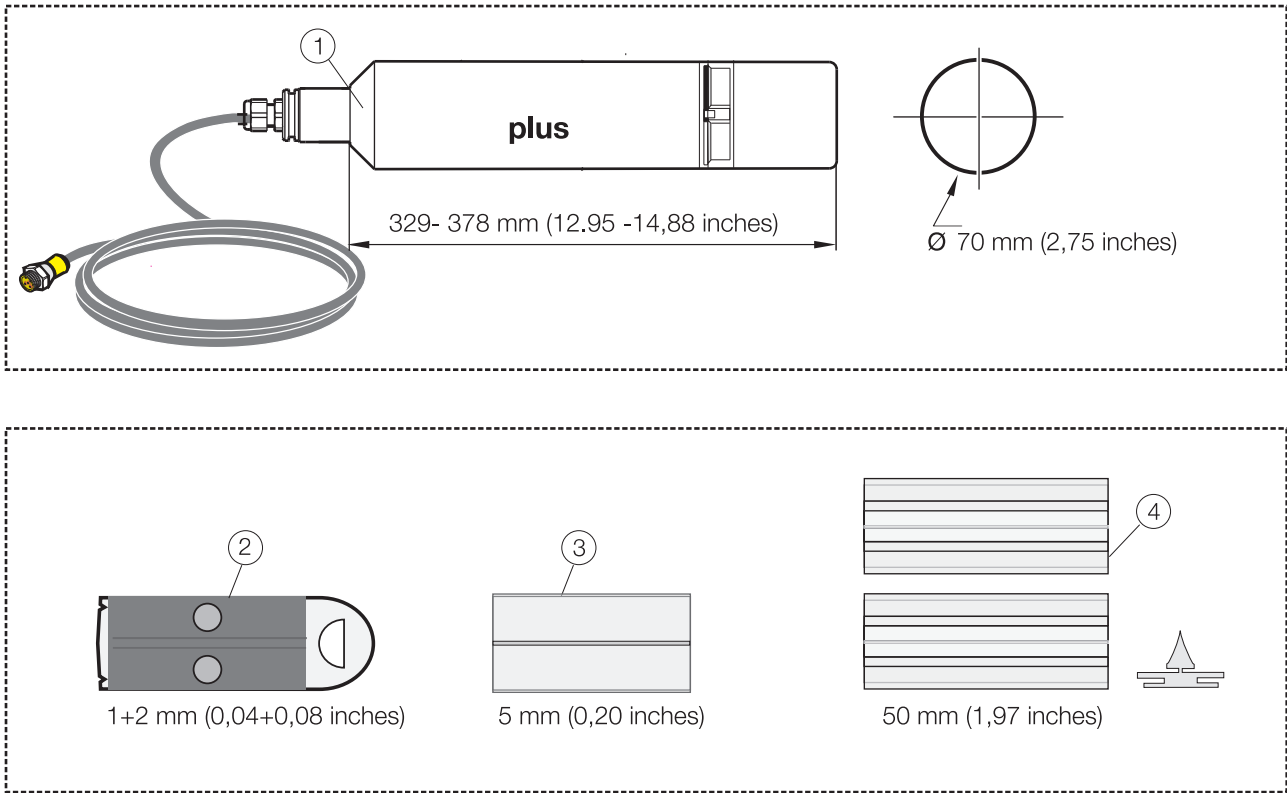

1. UVAS sc sensor	3. Wiper profile (5 mm)
2. Wiper profile (1 and 2 mm)	4. Wiper profile (50 mm)

Figure 3 Sensor bracket components

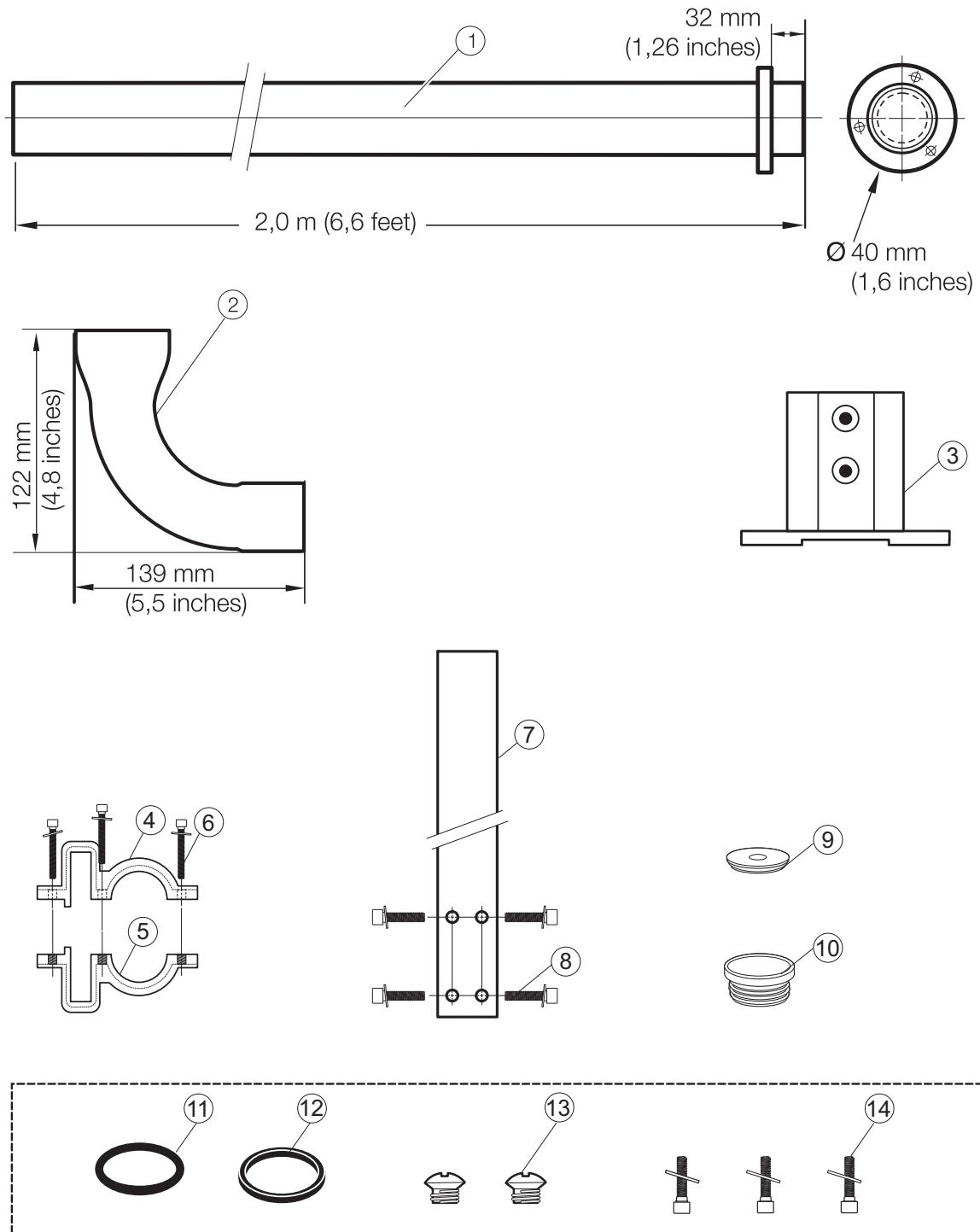

1. Mounting pipe 2.0 m	8. Cheese head bolt M8 x 40 (4)
2. 90° adapter	9. Sealing plug
3. Base	10. Plug
4. Clamp half (2)	11. O-ring EPDM
5. Clamp half with thread (2)	12. Flat seal
6. Cheese head bolt M5 x 20 (6)	13. Countersunk head bolt M6 x 8 (2)
7. Fastening lug	14. Cheese head bolt M3 x 10 (3)

Figure 4 UVAS plus sc bypass accessories

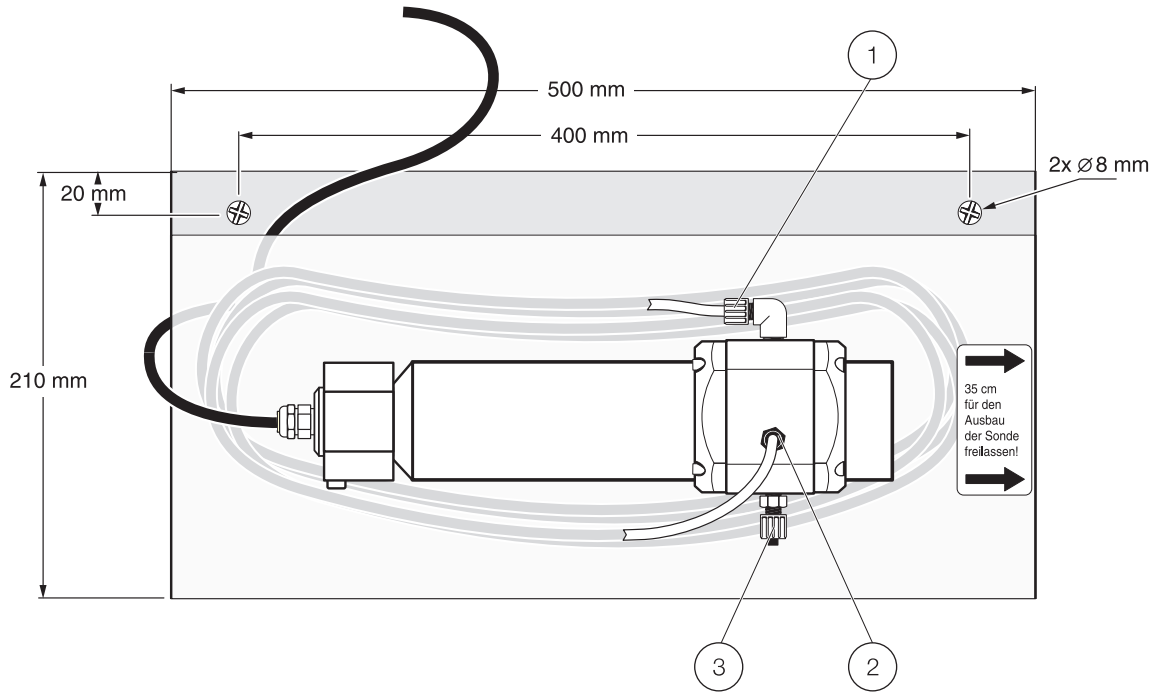

1. Sample waste	2. Sample feed	3. Drain plug
-----------------	----------------	---------------

Figure 5 Installation overview, sensor bracket

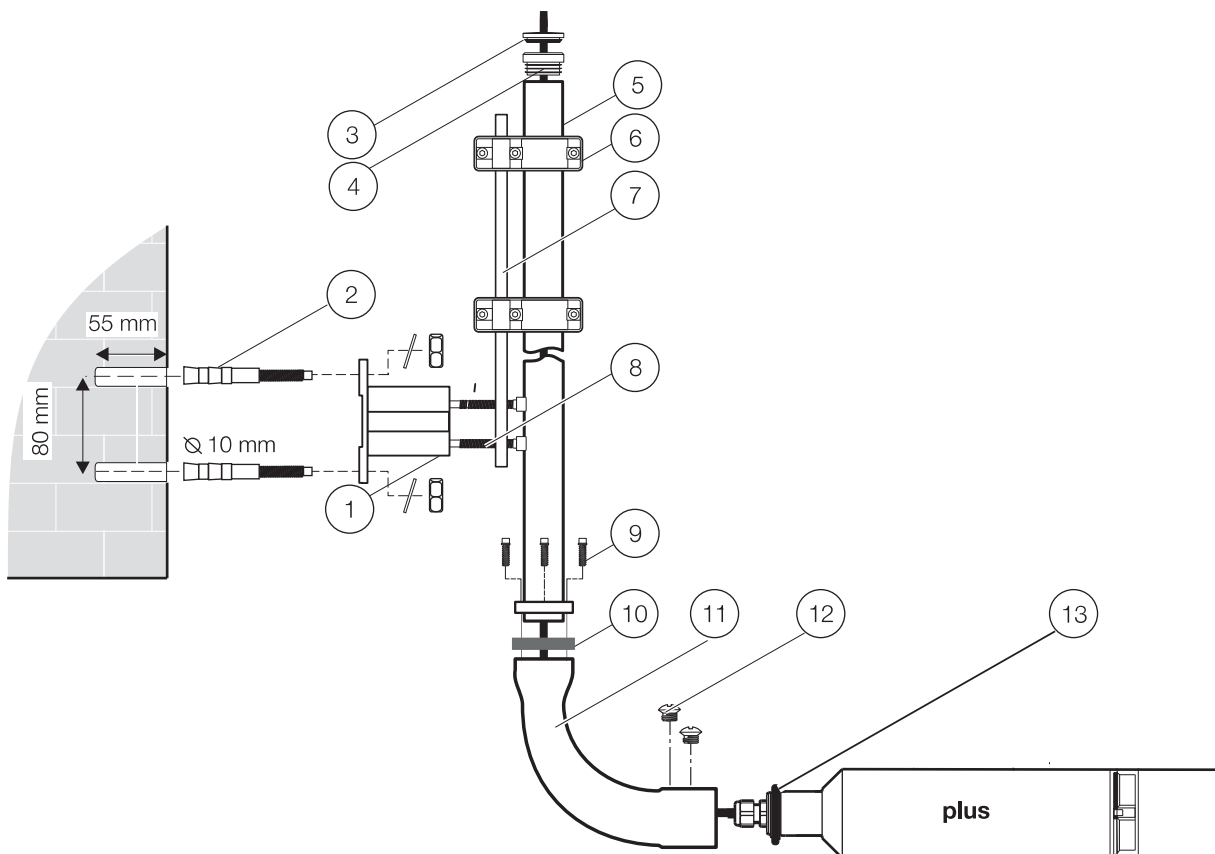

1. Base	8. Cheese head bolt M8 x 40 (4)
2. (Anchors)	9. Cheese head bolt with washer M3 x 10 (3)
3. Sealing plug	10. Flat seal
4. Plug	11. Adapter 90°
5. Mounting pipe 2.0 m	12. Countersunk head bolt M6 x 8 (2)
6. Retaining clamp (2)	13. O-ring EPDM
7. Fastening lug	

3.3 Attaching the Sensorcable

3.4 Wiring safety information

⚠ WARNING

Electrical shock hazard. Always disconnect power to the instrument when making any electrical connections.

3.4.1 Sensor connection and wiring

⚠ CAUTION

Before power is applied, refer to the controller operation instructions.

The sensor cable is supplied with a keyed quick-connect fitting for easy attachment to the controller. Retain the connector cap to seal the connector opening in case the sensor must be removed. Optional extension cables may be purchased to extend the sensor cable length.

Figure 6 Attaching the Sensor using the Quick-connect Fitting

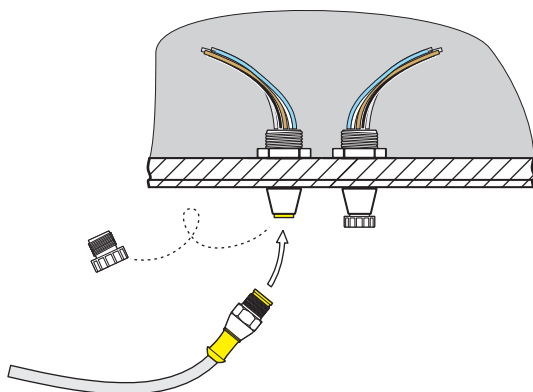
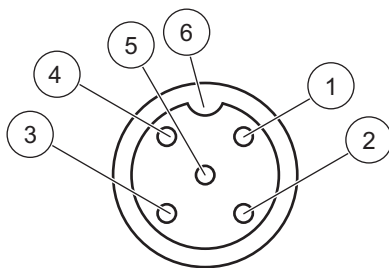

Figure 7 Quick-connect Fitting pin assignment



Number	Designation	Wire Color
1	+12 VDC	Brown
2	Circuit Common	Black
3	Data (+)	Blue
4	Data (-)	White
5	Shield	Shield (grey wire in existing quick-disconnect fitting)
6	Groove	

4.1 sc controller operation

The sensor can be operated with all sc controllers. Become familiar with the functionality of the sc controller before using the sensor. Learn how to navigate the menu and execute the corresponding functions.

4.2 Sensor setup

When the sensor is connected for the first time, the sensor serial number is displayed as the sensor name. The sensor name can be changed as follows.

1. Open the MAIN MENU.
2. Press SENSOR SETUP and confirm.
3. Select the corresponding sensor and confirm.
4. Select CONFIGURE and confirm.
5. Press EDITED NAME and confirm.
6. Edit the names and confirm to return to the CONFIGURE menu.

Complete the system configuration in the same way by defining settings for the following menu items:

- SET PARAMETER
- MEAS UNIT
- MEAS INTERVAL
- CORRELATION
- REFERENCE
- MEAS INTERVAL
- RESPONSE TIME
- CLEANING
- WIPER MODE
- BYPASS
- SET DEFAULTS

4.3 Sensor data logger

A data storage unit and an event memory unit are provided for each sensor. The data storage unit stores measurement data at predefined time intervals, while the event memory unit stores events such as configuration changes, alarms and warning conditions. Both storage units can be output in CSV format (refer to sc controller manual).

4.4 Menu structure

4.4.1 SENSOR STATUS

SELECT SENSOR (if there is more than one sensor)	
ERRORS	
	Possible error messages: MOIST, R < M, DEXT < 0.0, W. POS. UNKNOWN., W. BLOCKED, FLASH FAILURE, R TOO HIGH
WARNINGS	
	Possible warnings: EM TOO HIGH, CONC. TOO HIGH, CHECK KALIBR., REPLACE PROFILE, SERVICE REQUIRED, REPLACE SEALS, REPL. MOTOR S.

Note: Refer to [Section 6 Troubleshooting, page 31](#) for a list of all error and warning messages as well as a description of all necessary corrective actions.

4.4.2 SENSOR setup

SELECT SENSOR (if there is more than one sensor)			
CALIBRATION			
FACTOR			Adjustable from 0.80-1.20 for matching the comparison measurements
OFFSET			Adjustable from -250 to +250 mE for zero point correction
ZERO CAL		See 4.5.2 Zero point calibration, page 23	
1 SAMPLE CAL		See 4.5.3 1 point calibration, page 23	
VERIFY		See 4.6.1 Zero point adjustment, page 24	
CAL. CONFIG	OUTPUT MODE	ACTIVE	Behaviour of the outputs during calibration or zero point setting
		HOLD	
		TRANSFER	
		SELECTION	
	CAL INTERVAL	Counter for customer cal. 0-30 d, default setting: 0 d	
SET CAL DEFLT			

4.4.2 SENSOR setup

SELECT SENSOR (if there is more than one sensor)			
CONFIGURATION			
EDIT NAME	10-character		
PARAMETER	SAK254, SAC254, Ext254, Abs254, T/cm, BODuv, BSBuv, CSBuv, CODuv, DOCuv, TOCuv, ...		
MEAS UNIT	1/m, mE, AU, %, mg/l, ppm		
CORRELATION	2 value pairs: 1[1/m] and 1[mg/l] - 2[1/m] and 2[mg/l]		
REFERENCE	ON/OFF		
MEAS INTERVAL	15, 20, 30 sec; 1, 2, 3, 4, 5, 6, 10, 12, 15, 20, 30 min		
RESPONSE TIME	1-12 x MEAS INTERVAL	Indication of the actual response time in min.	
CLEANING	1/measurement, 1, 2, 3, 5, 6, 10, 12, 15, 20, 30 min, 1, 2, 3, 4, 6, 12 h, 10:00h		
WIPER MODE	SINGLE	Normal setting	
	DOUBLE A-B-A	Double wiping frequency	
	DOUBLE B-A-B	Double wiping frequency	
BYPASS	yes/no		WIPER MODE: B Inhibit wiper "extension"
SET DEFAULTS	ARE YOU SURE?	MEAS INTERVAL: 5 min RESPONSE TIME: 15 min WIPER MODE: B-A-B	Reset to the factory configuration.

4.4.2 SENSOR setup

SELECT SENSOR (if there is more than one sensor)			
MAINT.PROC			
PROBE INFO	UVAS plus sc		Instrument name
	EDIT NAME		
	SERIAL NUMBER		
	FILTER DATA		Measuring and reference wavelengths
	RANGE		
	PATHLENGTH		Width of the measuring path
	WIPER P/N		Item number
	MODEL NUMBER		Item number
	CODE VERSION		Sensor software
	DRIVER VERS		
	PRODUCTION DATE		Production date
CAL. DATA	OFFSET		Adjustable on the CALIBRATION menu
	FACTOR		
	a		Internal factor
	b		Internal factor
	DATE		Date of the last change of OFFSET and/or FACTOR
	STD.: 3000 mE		Internal calibration data
	DEXT 100%		
	DEXT 50%		
	DEXT 25%		
	GAIN		Instrument factor
	CAL.		Date of the last factory calibration
	r		Internal calibration data
	m		
	ir		
im			
COUNTERS	TOTAL TIME	Counters	
	REPLACE PROFILE	Counter 50000-0-neg. number	Negative if passed
	CHECK CALIBR.	Counter for test interval	
	SERVICE	Counter 180 d-0-neg. number	
	SEALS	Counter 365 d-0-neg. number	
	SHAFTSEALS	Counter 500000-0-neg. number	
	MOTOR	Counters	
	FLASH	Counters	

4.4.2 SENSOR setup

SELECT SENSOR (if there is more than one sensor)			
MAINT.PROC	OUTPUT MODE information	REPLACE PROFILE	See 5.3 Changing wiper profile, page 29
		WIPERTEST	WIPE (<i>wiping process</i>)
			DRIVE OUT WIPER <i>(wiper profile extends, on bypass versions inhibited: see 5.2 Cleaning measuring path, page 28</i>)
			MOTOR CURRENT (<i>motor current during the wiping process</i>)
		SIGNALS <i>(Measurement 1/sec)</i>	Average value
			Individual measured value
			Single measured value for AQS (FACTOR = 1, OFFSET = 0)
			W.POS (<i>wiper position</i>)
			DEXT (<i>delta extinction EM-ER</i>)
			EM (<i>extinction measuring channel</i>)
			ER (<i>extinction reference channel</i>)
			M (<i>measured level</i>)
			R (<i>reference level</i>)
			IM (<i>intensity measuring channel</i>)
			IR (<i>intensity reference channel</i>)
			rd (<i>dark value reference</i>)
			md (<i>dark value measuring channel</i>)
		extd (<i>dark value extinction</i>)	
		MOIST	
		OUTPUT MODE	Behaviour of the instrument outputs when the Maint.Proc. menu is opened

4.5 Calibration

The instrument has been carefully calibrated before delivery and the calibration will not change for a long time.

It is recommended to regularly check the calibration ([4.5.1 Verifying, page 22](#)) with a test glass. In case of large deviations, first a zero point calibration ([4.5.2 Zero point calibration, page 23](#)) must be performed to compensate for a zero point offset, before the gradient is allowed to be changed with the 1 point calibration ([4.5.3 1 point calibration, page 23](#)).

During the calibration only mE values are displayed. The setpoint adjustment is also referred to the unit of measure mE. This setpoint is noted on the filter for the verification, liquid standards must be measured with an external spectral photometer and the measured values converted to the sensor layer thickness.

4.5.1 Verifying

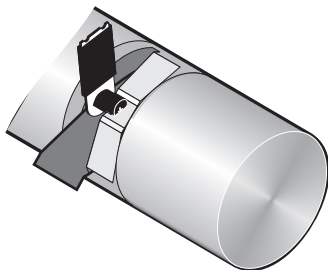
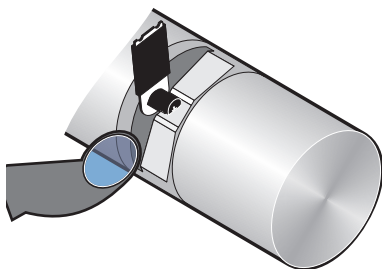
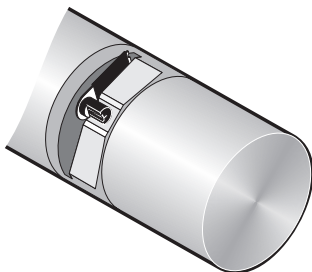

1. Open the MAIN MENU.
2. Press SENSOR SETUP and confirm.
3. Press SELECT SENSOR (if there is more than one sensor) and confirm.
4. Press CALIBRATION and confirm.
5. Remove sensor from the tank and rinse measuring path with water.
6. Press VERIFY and confirm. The wiper will come out.
7. Confirm INSERT FILTER PRESS ENTER TO CONTINUE...
8. Confirm WHEN STABLE PRESS ENTER X.X
9. Press CALIBRATION and confirm.
10. Edit in 1 SAMPLE-CAL. (+x.x) the setpoint adjustment according to the test glass and confirm.
11. Confirm FACTOR: X.XX.
12. The corrected measured value is displayed. Confirm WHEN STABLE PRESS ENTER X.X.
13. Press FINISH and confirm.
14. Confirm REMOVE FILTER PRESS ENTER.
Then the wiper moves out . Immerse sensor at the measuring location.
15. Press the back-button to leave the menu CALIBRATE.
16. Confirm RETURN PROBE TO PROCESS.
17. Confirm READY. Automatic wiping action and back to measurements.

4.5.2 Zero point calibration

1. Open the MAIN MENU.
2. Press SENSOR SETUP and confirm.
3. Press SELECT SENSOR (if there is more than one sensor) and confirm.
4. Press CALIBRATION and confirm.
5. Select ZERO CAL and confirm.
6. Remove sensor from the tank and rinse measuring path with water. Align measuring path horizontally and completely fill with distilled water. Confirm FILL IN AQUA DEST PRESS ENTER TO CONTINUE.
7. Confirm WHEN STABLE PRESS ENTER DEXT: +/- X.X mE.
8. Press CALIBRATION and confirm.
9. Select OFFSET: X.X mE.
10. Confirm WHEN STABLE PRESS ENTER +/- X.X.
11. Press FINISH and confirm.
12. Press the back-button to leave the menu CALIBRATE.
13. Immerse sensor at the measuring location and confirm RETURN PROBE TO PROCESS.
14. Confirm READY. Automatic wiping action and back to measurements.

4.5.3 1 point calibration

1. Open the MAIN MENU.
2. Press SENSOR SETUP and confirm.
3. Press SELECT SENSOR (if there is more than one sensor) and confirm.
4. Press CALIBRATION and confirm.
5. Select 1 SAMPLE CAL and confirm.
6. Remove sensor from the tank and rinse measuring path with water. Align measuring path horizontally and completely fill with a reference sample. Confirm FILL IN CAL STANDARD PRESS ENTER.
7. Confirm WHEN STABLE PRESS ENTER x. x.
8. Press CALIBRATION and confirm.
9. Edit in 1 SAMPLE-CAL. (+x.x) the setpoint adjustment according to the reference sample and confirm.

10. Confirm FACTOR: X.XX.
11. Confirm WHEN STABLE PRESS ENTER X.X.
12. Press FINISH and confirm.
13. Press the back-button to leave the menu CALIBRATE.
14. Immerse sensor at the measuring location and confirm RETURN PROBE TO PROCESS.
15. Confirm READY. Automatic wiping action and back to measurements.

4.6 Adjusting measured values

If the comparative measurements in the laboratory do not provide adequate agreement with the measured values from the probe, electronic measured value adjustment (zero point and factor) can be performed as a provisional measure until the next customer service visit.

The settings should also only be made when a zero point check after cleaning the measuring window and the verification have been unsatisfactory.

4.6.1 Zero point adjustment

1. Open the MAIN MENU.
2. Press SENSOR SETUP and confirm.
3. Press SELECT SENSOR (if there is more than one sensor) and confirm.
4. Press CALIBRATION and confirm.
5. Press OFFSET and confirm.
6. Make a manual zero point offset by editing xx mE and confirm.
7. Press the back-button to leave the menu CALIBRATE.
8. Immerse sensor at the measuring location and confirm RETURN PROBE TO PROCESS.
9. Confirm READY. Automatic wiping action and back to measurements.

4.6.2 Setting factor

1. Open the MAIN MENU.
2. Press SENSOR SETUP and confirm.
3. Press SELECT SENSOR (if there is more than one sensor) and confirm.
4. Press CALIBRATION and confirm.
5. Press FACTOR and confirm.

6. Edit the Factor x.xx and confirm. The current measured value is multiplied by this factor, from 0.80-1.20, before it appears as a calculated value on the display.
7. Press the back-button to leave the menu CALIBRATE.
8. Immerse sensor at the measuring location and confirm RETURN PROBE TO PROCESS.
9. Confirm READY. Automatic wiping action and back to measurements.

4.7 Conversion into other total parameters

SAC 254 is an independent total parameter for the dissolved organic content of water and evaluates, like all other total parameters, only ever a specific fraction of the water load. Despite their major similarities, total parameters can only be converted from one to another within certain limits. However, if a correlation is found between SAC 254 and another total parameter, the converted measured values from UVAS probes can be displayed as mg/l TOCuv, CSBuv etc.

To determine the correlation, first a measurement of the SAC curve should be made over a few days. Only a regular daily curve with pronounced low and high load times such as with municipal waste water offers a good basis for satisfactory conversion.

At the times of day found for low and high load

- A representative sample should be taken at the UVAS probe location,
- The related SAC value should be read and
- A laboratory measurement of the parameter to be correlated should be made.

Example:

Sample 1 SAC 254: 105 1/m ; TOC: 150 mg/l:

Sample 2 SAC 254: 35 1/m ; TOC: 38 mg/l:

SENSOR SETUP			
	CONFIGURATION		
		SET PARAMETER	TOCuv
		MEAS UNIT	mg/l
		CORRELATION	PAIR 1 1 [1/m] = 105 1 [mg/l] = 150 PAIR 2 2 [1/m] = 35 2 [mg/l] = 38

The correlation entered should be regularly checked by means of comparative measurements in the laboratory.

⚠ CAUTION

Pinch Hazard. Only qualified personnel should conduct the tasks described in this section of the manual.

The cleanliness of the two measuring windows in the sensor measuring path is crucial for correct measured results!

The measuring windows should be checked weekly for soiling and the wiper profile checked for wear.

NOTICE

The seals must be replaced annually by the manufacturer's customer service! If the seals are not changed regularly, water may enter the probe head and seriously damage the instrument!

5.1 Maintenance schedule

Maintenance task	
Visual inspection	weekly
Check calibration	Comparative measurement weekly <i>(depending on the ambient conditions)</i>
Inspection	six months (counter)
Seal change	annually (counter)
Wiper profile change	as per counter

Consumables		
Number	Designation	Average service life*
1	Wiper sets	1 year
1	Wiper motor	5 years
1	Seal set	1 year
1	Flash lamp	10 years
2	Measuring windows	5 years
1	Filter set	5 years
2	O-ring through-flow unit	1 year

* On operation as per factory settings and correct use

5.2 Cleaning measuring path

DANGER

Potential danger with contact with chemical/biological substances.
Working with chemical samples, standards and reagents can be dangerous.
Make yourself familiar with the necessary safety procedures and the correct handling of the chemicals before use and read and follow all relevant safety data sheets.

Normal operation of this device may require the use of chemicals or samples that are biologically unsafe.

- Observe all cautionary information printed on the original solution containers and safety data sheets prior to their use.
- Dispose of all consumed solutions in accordance with the local and national regulations and laws.
- Select the type of protective equipment suitable to the concentration and quantity of the dangerous material being used.

If the wiper interval is set correctly and the wiper profile is changed on time, additional cleaning of the measuring path is not necessary.

1. Open the MAIN MENU.
2. Press SENSOR SETUP and confirm.
3. Press SELECT SENSOR (if there is more than one sensor) and confirm.
4. Press DIAG/TEST and confirm.
5. Press TEST/MAINT and confirm.
6. Press SIGNALS and confirm.
7. Remove sensor from the tank.
Depending on the degree and nature of the soiling, clean using window cleaner, grease remover or 5 % hydrochloric acid (operating the wiper arm using the Enter key can help the cleaning process.)

After leaving to soak for 5–10 minutes, you must carefully clean the measuring path with distilled water. Objective: [ER] and [EM] < 500

Confirm ENTER=WIPE.

8. Press the back-button to leave the menu SIGNALS.
9. Press the back-button to leave the menu TEST/MAINT. Confirm RETURN PROBE TO PROCESS.
10. Confirm READY. Automatic wiping action and back to measurements.

5.3 Changing wiper profile

⚠ CAUTION

Obey the locally applicable accident prevention regulations. Wear protective gloves where necessary during the change of the wiper rubber.

Note: Note for bypass version: First slide the sensor out of the through-flow cell until the measuring path is visible and the wiper can be extended without resistance!

1. For this purpose on the menu SENSOR SETUP, CONFIGURATION, Set BYPASS to "no"!

Figure 8 Changing wiper profile

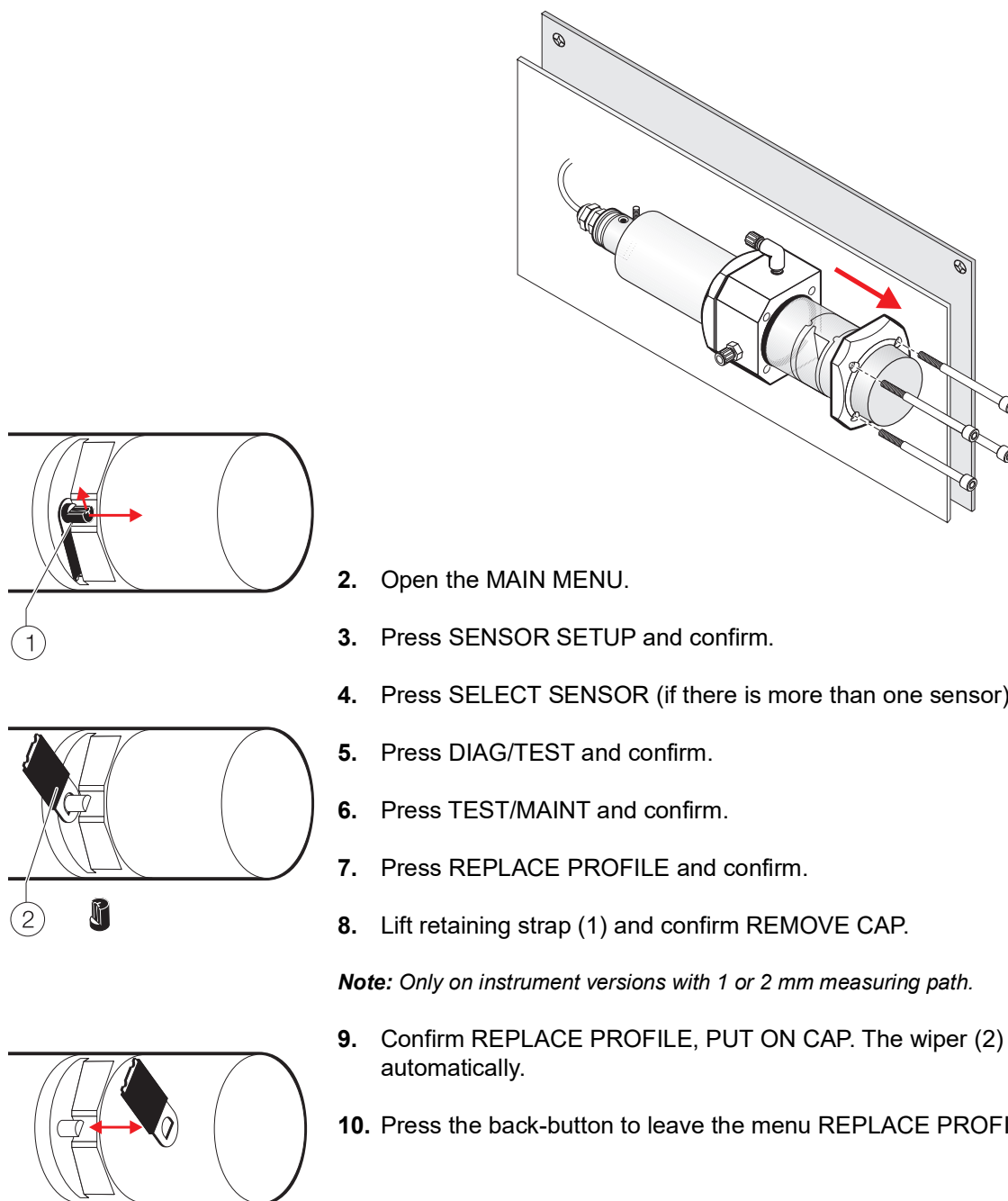

2. Open the MAIN MENU.
3. Press SENSOR SETUP and confirm.
4. Press SELECT SENSOR (if there is more than one sensor) and confirm.
5. Press DIAG/TEST and confirm.
6. Press TEST/MAINT and confirm.
7. Press REPLACE PROFILE and confirm.
8. Lift retaining strap (1) and confirm REMOVE CAP.

Note: Only on instrument versions with 1 or 2 mm measuring path.

9. Confirm REPLACE PROFILE, PUT ON CAP. The wiper (2) moves out automatically.
10. Press the back-button to leave the menu REPLACE PROFILE.

11. Immerse sensor at the measuring location and confirm RETURN PROBE TO PROCESS.
12. Confirm READY. Automatic wiping action and back to measurements.

5.4 Seal change (bypass version)

5.4.1 UVAS *plus* sc

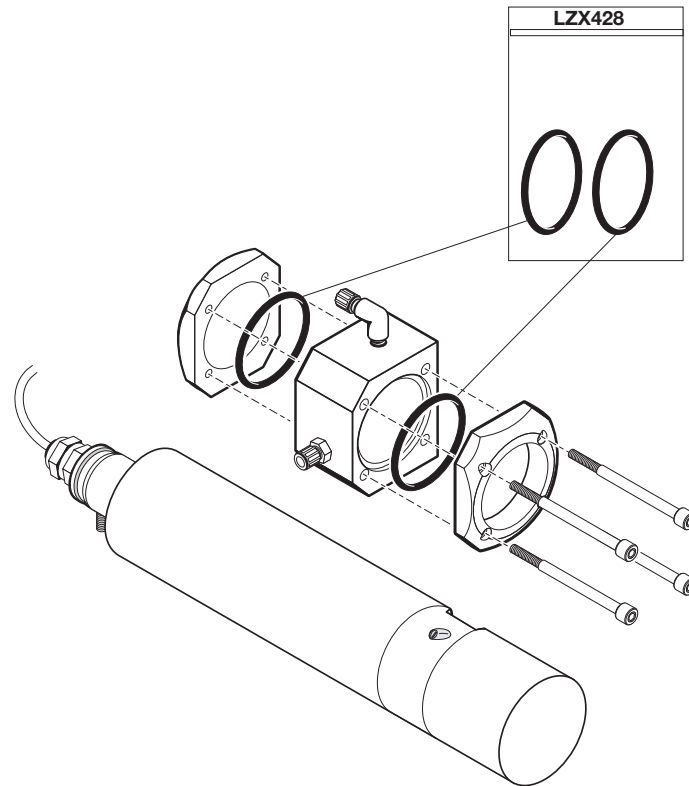

6.1 Error messages

Possible sensor error messages are displayed by the sc controller.

Table 4 Error messages

Error displayed	Rectification
NONE	
MOIST	Check MOIST value on the SENSOR SETUP menu, TEST/MAINT, MAINT.PROC., SIGNALS. Remove sensor from the tank and call service
R < M	Call service
DEXT < 0.0	Check calibration, call service
W.POS. UNKNOWN	Check measuring path, call service
W. BLOCKED	Check measuring path, call service
FLASH FAILURE	Call service
R TOO HIGH	Call service

6.2 Warnings

Possible sensor warning messages are displayed by the sc controller.

Table 5 Warnings

Warning displayed	Cause	Rectification
NONE	Correct measuring operation	
EM TOO HIGH	Turbidity, organic content or nitrate concentration too high, measuring range exceeded as a result	Check measurement in the laboratory
CONC. TOO HIGH	Nitrate concentration too high, as a result measuring range exceeded	Check measurement in the laboratory
CHECK KALIBR.	Test interval elapsed	Check calibration
REPLACE PROFILE	Counter elapsed	Change wiper profile
SERVICE REQUIRED	Counter elapsed	Call service
REPLACE SEALS	Counter elapsed	Call service
SHAFT SEALS REPL.	Counter elapsed	Call service

UVAS <i>plus</i> sc (1 mm)	LXV418.00.10001
UVAS <i>plus</i> sc (2 mm)	LXV418.00.20001
UVAS <i>plus</i> sc (5 mm)	LXV418.00.50001
UVAS <i>plus</i> sc (50 mm)	LXV418.00.90001
User Manual	DOC023.54.03230

Accessories

Cable extension set (5 m).....	LZX848
Cable extension set (10 m).....	LZX849
Cable extension set (15 m).....	LZX850
Cable extension set (20 m).....	LZX851
Cable extension set (30 m).....	LZX852
Cable extension set (50 m).....	LZX853
Cable extension set (100 m).....	LZY339
Sensor bracket incl. 90° adapter	LZY714.99.53520
Comprising:	
Base	LZY827
Fastening lug.....	LZY804
Retaining clamp (2x).....	LZX200
Mounting pipe 2 m.....	LZY714.99.00020
Hardware HS.....	LZY823
Extension pipe 1.8 m.....	LZY714.99.00040
Extension pipe 1.0 m.....	LZY714.99.00030
Second fastening point (incl. retaining clamp).....	LZY714.99.03000
Probe adapter 90°	LZY714.99.50000
Hardware, sensor fastening.....	LZY822

Consumables

Wiper profile 1 mm (5 pcs.)	LZX148
Wiper profile 2 mm (5 pcs.)	LZX012
Wiper profile 5 mm (5 pcs.)	LZX117
Wiper profile 50 mm (20 pcs.)	LZX119

Table 6 Sensor ModBUS Registers

Group Name	Register #	Data Type	Length	R/W	Description
measurement	40001	Float	2	R	diplayed measurement value
unit	40003	Unsigned Integer	1	R/W	unit : mg/l = 0 : g/l = 1
parameter	40004	Unsigned Integer	1	R/W	parameter
Measure interval	40005	Unsigned Integer	1	R/W	measuring interval
correction	40006	Float	2	R/W	correction
offset	40008	Float	2	R/W	offset
integration	40010	Unsigned Integer	1	R/W	integration, always 1
cleaning_interval	40011	Unsigned Integer	1	R/W	cleaning interval
wiper mode	40012	Unsigned Integer	1	R/W	wiper mode
wiper state	40013	Unsigned Integer	1	R/W	wiper state
resp time	40014	Unsigned Integer	1	R/W	response time
drv_struct_ver	40015	Unsigned Integer	1	R	driver structure version
drv_firmw_ver	40016	Unsigned Integer	1	R	driver firmware version
drv_cont_ver	40017	Unsigned Integer	1	R	driver content version
location	40018	String	5	R/W	location
path length	40023	Float	2	R	path length
profile	40025	Integer	2	R	profile counter
motor_cycles	40027	Integer	2	R	motor cycles
flash_counter	40029	Integer	2	R	flash counter
sealing_counter	40031	Integer	2	R	sealing counter
service_counter	40033	Integer	2	R	service counter
operating_hours	40035	Integer	2	R	operating hours
shaft_sealing_counter	40037	Integer	2	R	shaft sealing counter
profile reset val	40039	Integer	2	R/W	profile reset val
seals reset val	40041	Integer	2	R/W	seals reset val
service reset val	40043	Integer	2	R/W	service reset val
shaft seal reset val	40045	Integer	2	R/W	shaft seal reset val
des_measurement	40047	Float	2	R	desired measurement value
meas_single_value	40049	Float	2	R	measurement single value
dext	40051	Float	2	R	delta extinction
EM	40053	Float	2	R	m - extinction
ER	40055	Float	2	R	r - extinction
M	40057	Float	2	R	m
R	40059	Float	2	R	r
intensity_mes	40061	Float	2	R	m - intensity
intensity_ref	40063	Float	2	R	r - intensity
humidity_main	40065	Float	2	R	humidity - main
conc_blank	40067	Float	2	R	concentration without correction
cal_date	40069	Time	2	R	calibration time and date
user_cal_date	40071	Time	2	R	user calibration time and date
std_s3	40073	Float	2	R	standard S3
cal_L1	40075	Float	2	R	cal. point 1

ModBUS Register Information

Table 6 Sensor ModBUS Registers

cal_L2	40077	Float	2	R	cal. point 2
cal_L3	40079	Float	2	R	cal. point 3
cal_mes	40081	Float	2	R	m - calibration
cal_ref	40083	Float	2	R	r - calibration
cal_intensity_mes	40085	Float	2	R	intensity m - calibration
cal_intensity_ref	40087	Float	2	R	intensity r - calibration
cal_ext	40089	Float	2	R	extinction - calibration
process	40091	Unsigned Integer	1	R/W	process register
menu	40092	Unsigned Integer	1	R	menu state
gain_ref	40093	Integer	1	R	low byte = gain ref-channel, high byte = second cap. on/off
gain_mes	40094	Integer	1	R	low byte = gain mes-channel, high byte = second cap. on/off
wiper_lim_a	40095	Integer	1	R	wiper limit a
wiper_lim_b	40096	Integer	1	R	wiper limit b
wiper_lim_out	40097	Integer	1	R	wiper limit out
prg_vers	40098	String	4	R	program version
ser_no	40102	Integer	2	R	serial number
cal_out_cfg	40104	Integer	1	R	cal. Output mode
user_cal_int	40105	Integer	1	R/W	user calibration interval
wiper_current	40106	Integer	1	R	wiper motor current in mA
resp_time_min	40107	Integer	1	R	response time in min
flash_per_fil	40108	Integer	2	R	flash per filter
cm1	40110	Float	2	R/W	meas. Cap 1
cm2	40112	Float	2	R/W	meas cap 2
cr1	40114	Float	2	R/W	ref cap1
cr2	40116	Float	2	R/W	ref cap2
lambda_m	40118	Float	2	R/W	lambda meas
lambda_r	40120	Float	2	R/W	lambda ref
transm_m	40122	Float	2	R/W	transmission meas
transm_r	40124	Float	2	R/W	ransmission ref
cal_menu	40126	Unsigned Integer	1	R/W	cal menu
wiper_menu	40127	Unsigned Integer	1	R/W	wiper menu
maint_menu	40128	Unsigned Integer	1	R/W	maint_menu
service_menu	40129	Unsigned Integer	1	R/W	service menu
flash_repl	40130	Unsigned Integer	1	R/W	flash replaced question
edit_menu	40131	Unsigned Integer	1	R/W	edit menu
def_menu	40132	Unsigned Integer	1	R/W	default menu
filter_data_menu	40133	Unsigned Integer	1	R/W	filter data menu
prod_date	40134	Time	2	R	production date
sensor_type	40136	String	8	R/W	sensor type
filter_set	40144	String	3	R/W	filter set
user_cal_counter	40147	Integer	1	R	user cal. Counter
pos_out_en	40148	Unsigned Integer	1	R/W	pos. Out enable

HACH COMPANY World Headquarters

P.O. Box 389, Loveland, CO 80539-0389 U.S.A.
Tel. (970) 669-3050
(800) 227-4224 (U.S.A. only)
Fax (970) 669-2932
orders@hach.com
www.hach.com

HACH LANGE GMBH

Willstätterstraße 11
D-40549 Düsseldorf, Germany
Tel. +49 (0) 2 11 52 88-320
Fax +49 (0) 2 11 52 88-210
info-de@hach.com
www.de.hach.com

HACH LANGE Sàrl

6, route de Compois
1222 Vézenaz
SWITZERLAND
Tel. +41 22 594 6400
Fax +41 22 594 6499

